

# New possibilities with our tools!

Across the world, there is an explosion of tungsten carbide tipped tool makers. From the familiar to the ingenious. Our ingenuity is in helping you discover new synergies and possibilities with our tools.

With more than 30 years of manufacturing and application engineering experience, we have been making tungsten carbide tipped tools. Our delighted customer base is in the Indian and foreign markets like Japan, UK, Germany, USA and Singapore and are from sectors like automobile, aerospace, and heavy engineering.

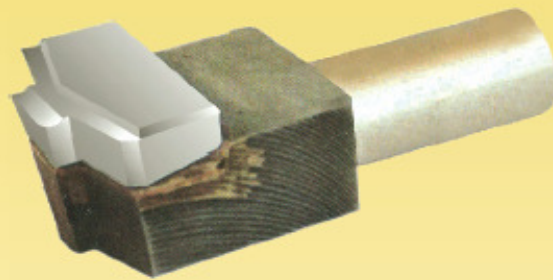

The tungsten carbide tips used in our tools are from leading manufacturers like KENNAMETAL WIDIA. Our range of tools consists of ISO, BSS, DIN, and JIS standards. We also make special tools as per your drawings/applications.

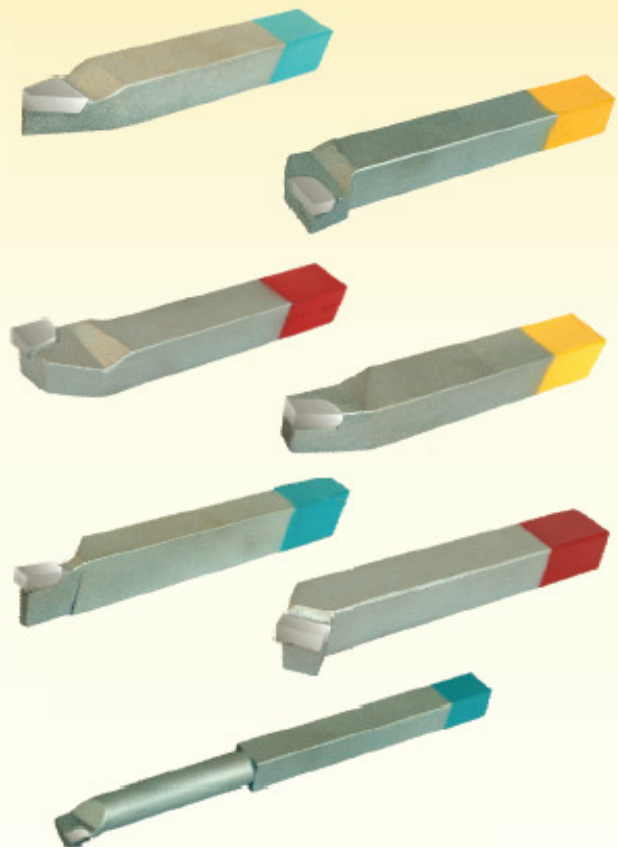

We will be privileged to associate with you. Please address your queries to:



## Tectools Engineering Company

Omkar Industrial Estate, Site No. 50/10, CBK Village,  
9th Mile, Tumkur Road, Nagasandra Post,  
Bangalore-560 073. INDIA.

Tel : +91(0)80 2839 6929, Fax : +91(0)80 2372 2926

Email : tectoolsco@yahoo.com

sritec\_25@yahoo.com

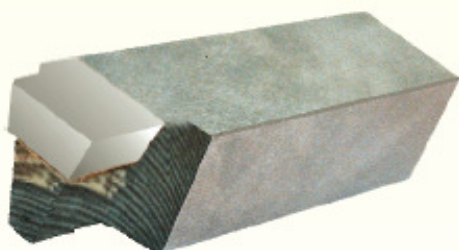
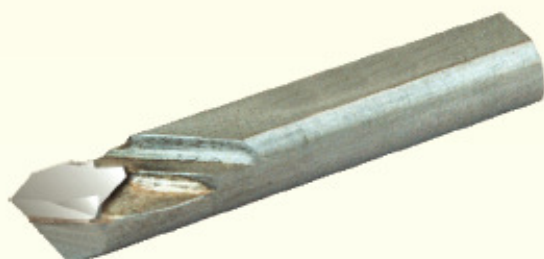

# TTEC

## Hardmetal Tipped Tools

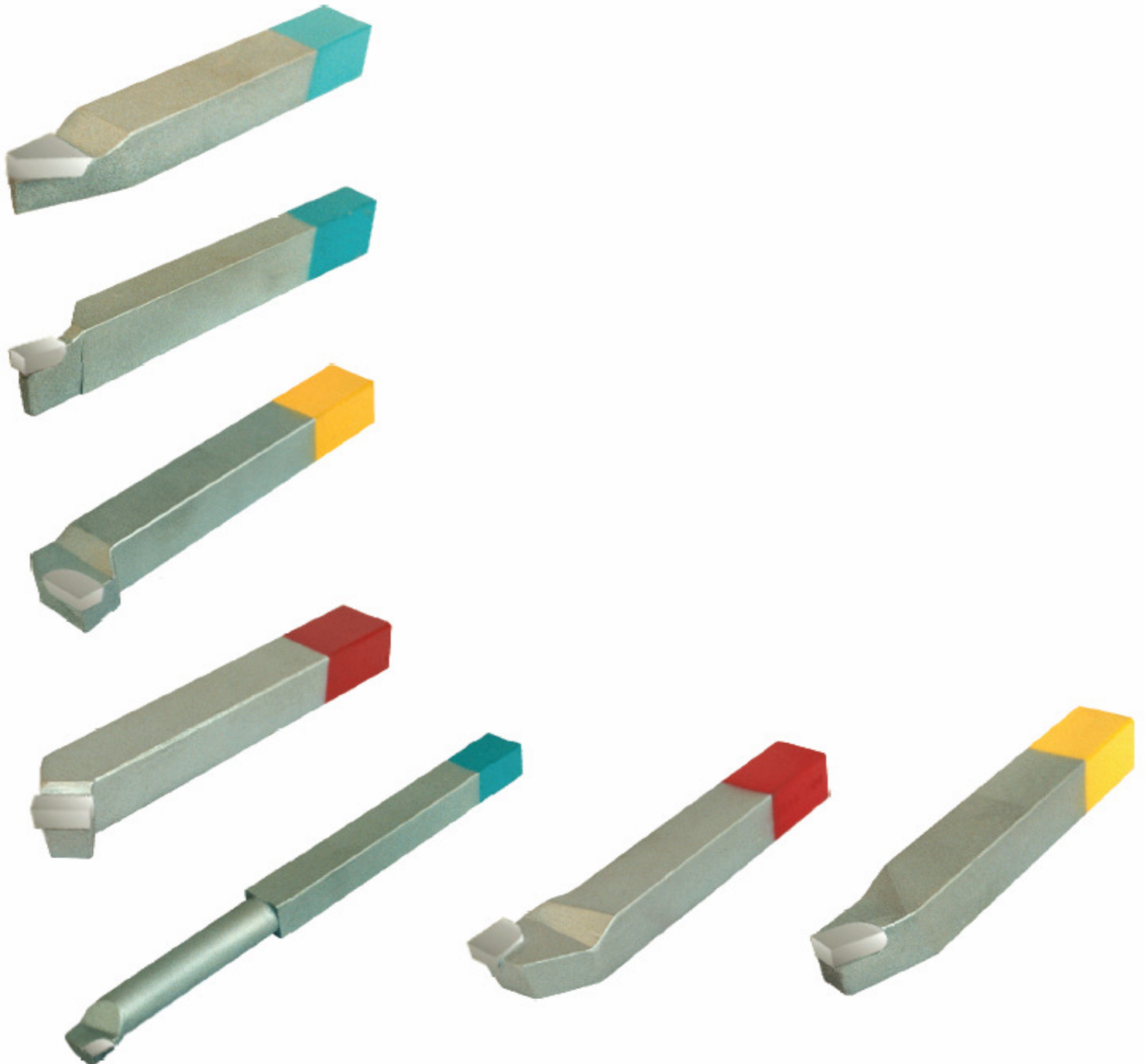

# Contents

---

TTEC Hardmetal Tipped Tools	Page
a ISO 1 / ISO 2	2
b ISO 3 / ISO 4	3
c ISO 5 / ISO 6	4
d ISO 7	5
e ISO 8 / ISO 9	6
f SRNT/CRNT	7
g BT 1 / BT 2 / BT 3	8
i ETT / ITT	9

# TTEC Hardmetal Tipped Tools

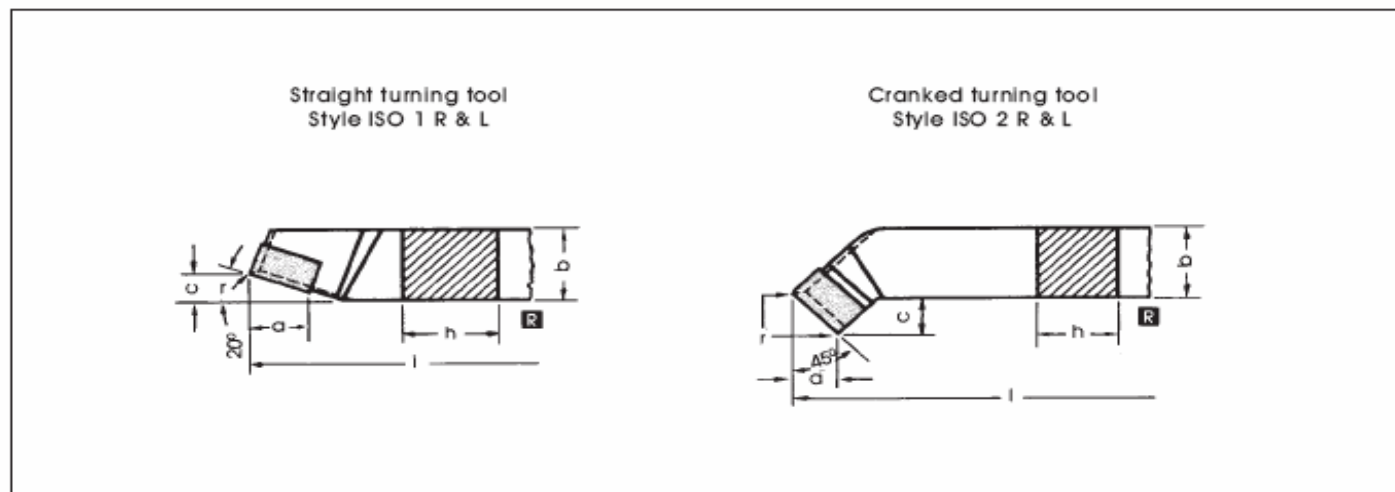

Shank Size	Dimensions in mm						Tip used
	h	b	l	c	a	r	
<b>Style ISO 1 R &amp; L</b>							
1010	10	10	90	4	7.5	0.4	C 8
1212	12	12	100	5	9.4	0.4	C 10
1616	16	16	110	6	11.2	0.4	C 12
2020	20	20	125	8	15.0	0.8	C 16
2525	25	25	140	10	18.8	1.2	C 20
3232	32	32	170	12	23.5	1.2	C 25
4040	40	40	200	16	30.0	1.6	C 32
1610	16	10	110	4	9.4	0.4	C 10
2012	20	12	125	5	11.2	0.4	C 12
2516	25	16	140	6	15.0	0.8	C 16
3220	32	20	170	8	18.8	1.2	C 20
4025	40	25	200	10	23.5	1.2	C 25
5032	50	32	240	12	30.0	1.6	C 32
<b>Style ISO 2 R&amp;L</b>							
1010	10	10	90	6	5.6	0.4	C 8
1212	12	12	100	7	7.0	0.4	C 10
1616	16	16	110	8	8.5	0.4	C 12
2020	20	20	125	10	11.3	0.8	C 16
2525	25	25	140	12	14.1	1.2	C 20
3232	32	32	170	14	17.6	1.2	C 25
4040	40	40	200	18	22.6	1.6	C 32
1610	16	10	110	7	7.0	0.4	C 10
2012	20	12	125	8	8.5	0.4	C 12
2516	25	16	140	10	11.3	0.8	C 16
3220	32	20	170	12	14.1	1.2	C 20
4025	40	25	200	14	17.6	1.2	C 25
5032	50	32	240	18	22.6	1.6	C 32

**Note :** The above Tools are supplied in ISO grades P30 & K20. Specials can be made to order. Please write to us with drawings.

Unless otherwise specified the above tools are supplied with :  
Rake angle : 10°

**HOW TO ORDER :** Please specify shank size, hand and grade.

# TTEC Hardmetal Tipped Tools

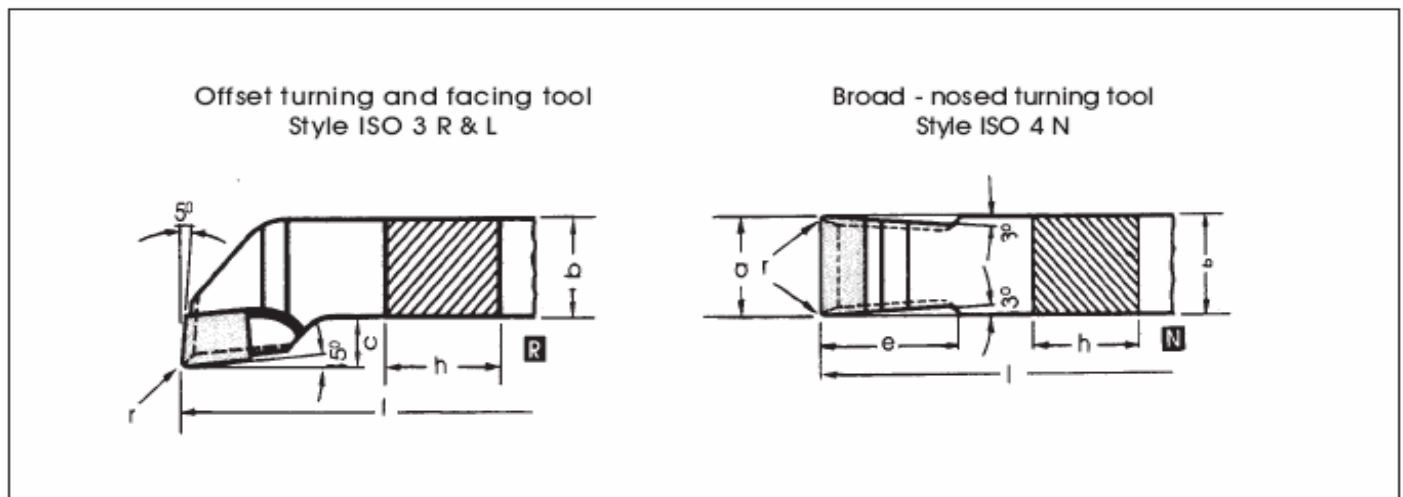

Shank Size	Dimensions in mm							Tip used
	h	b	l	c	e	a	r	
<b>Style ISO 3 R &amp; L</b>								
1010	10	10	90	5	-	-	0.4	C 8
1212	12	12	100	6	-	-	0.4	C 10
1616	16	16	110	8	-	-	0.4	C 12
2020	20	20	125	10	-	-	0.8	C 16
2525	25	25	140	12	-	-	1.2	C 20
3232	32	32	170	14	-	-	1.2	C 25
4040	40	40	200	20	-	-	1.6	C 32
1610	16	10	110	5	-	-	0.4	C 8
2012	20	12	125	6	-	-	0.4	C 10
2516	25	16	140	8	-	-	0.4	C 12
3220	32	20	170	10	-	-	0.8	C 16
4025	40	25	200	12	-	-	1.2	C 20
5032	50	32	240	14	-	-	1.2	C 25
<b>Style ISO 4 N</b>								
1010	10	10	90	-	10	10	0.4	C 10
1212	12	12	100	-	12	12	0.4	C 12
1616	16	16	110	-	16	16	0.8	C 16
2020	20	20	125	-	20	20	1.2	C 20
2525	25	25	140	-	25	25	1.2	C 25
3232	32	32	170	-	32	32	1.6	C 32
4040	40	40	200	-	40	40	2.0	C 40
1610	16	10	110	-	16	10	0.4	C 10
2012	20	12	125	-	20	12	0.4	C 12
2516	25	16	140	-	25	16	0.8	C 16
3220	32	20	170	-	32	20	1.2	C 20
4025	40	25	200	-	40	25	1.2	C 25
5032	50	32	240	-	50	32	1.6	C 32

Note : The above Tools are supplied in ISO grades P30 & K20. Specials can be made to order. Please write to us with drawings.

Unless otherwise specified the above tools are supplied with :  
Rake angle : 10°

HOW TO ORDER : Please specify shank size, hand and grade.



# TTEC Hardmetal Tipped Tools

Offset end - cutting tool  
Style ISO 5 R & L

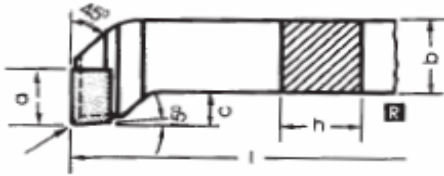

Offset side - cutting tool  
Style ISO 6 R & L

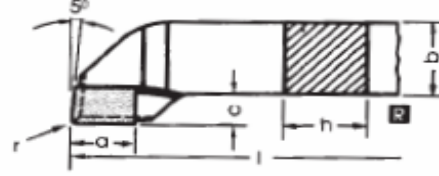

Shank Size	Dimensions in mm						Tip used
	h	b	l	c	a	r	
<b>Style ISO 5 R &amp; L</b>							
1010	10	10	90	5	8	0.4	C 8
1212	12	12	100	6	10	0.4	C10
1616	16	16	110	8	12	0.4	C12
2020	20	20	125	10	16	0.8	C16
2525	25	25	140	12	20	1.2	C20
3232	32	32	170	16	25	1.2	C25
4040	40	40	200	20	32	1.6	C32
1610	16	10	110	6	10	0.4	C10
2012	20	12	125	8	12	0.4	C12
2516	25	16	140	10	16	0.8	C16
3220	32	20	170	12	20	1.2	C20
4025	40	25	200	16	25	1.2	C25
5032	50	32	240	20	32	1.6	C32
<b>Style ISO 6 R &amp; L</b>							
1010	10	10	90	4	8	0.4	C 8
1212	12	12	100	5	10	0.4	C10
1616	16	16	110	6	12	0.4	C12
2020	20	20	125	8	16	0.8	C16
2525	25	25	140	10	20	1.2	C20
3232	32	32	170	12	25	1.2	C25
4040	40	40	200	14	32	1.6	C32
1610	16	10	110	5	10	0.4	C10
2012	20	12	125	6	12	0.4	C12
2516	25	16	140	8	12	0.8	C12
3220	32	20	170	10	20	1.2	C20
4025	40	25	200	12	25	1.2	C25
5032	50	32	240	14	32	1.6	C32

Note : The above Tools are supplied in ISO grades P30 & K20. Specials can be made to order. Please write to us with drawings.

Unless otherwise specified the above tools are supplied with :  
Rake angle : 10°

HOW TO ORDER : Please specify shank size, hand and grade.

# TTEC Hardmetal Tipped Tools

Recessing tool  
Style ISO 7 R & L

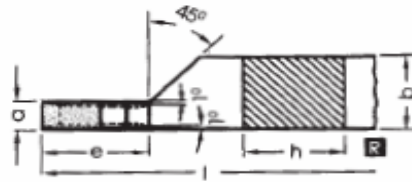

Shank Size	Dimensions in mm					Tip used
	h	b	l	e	a	
Style ISO 7 R & L						
1006	10	6	90	12	3	D 3
1208	12	8	100	12	3	D 3
1610	16	10	110	14	4	D 4
2012	20	12	125	16	5	D 5
2516	25	16	140	20	6	D 6
3220	32	20	170	25	8	D 8
4025	40	25	200	32	10	D 10
5032	50	32	240	40	12	D 12

**Note :** The above Tools are supplied in ISO grades P30 & K20. Specials can be made to order. Please write to us with drawings.

Unless otherwise specified the above tools are supplied with :  
Rake angle : 8°

**HOW TO ORDER :** Please specify shank size, hand and grade.

# TTEC Hardmetal Tipped Tools

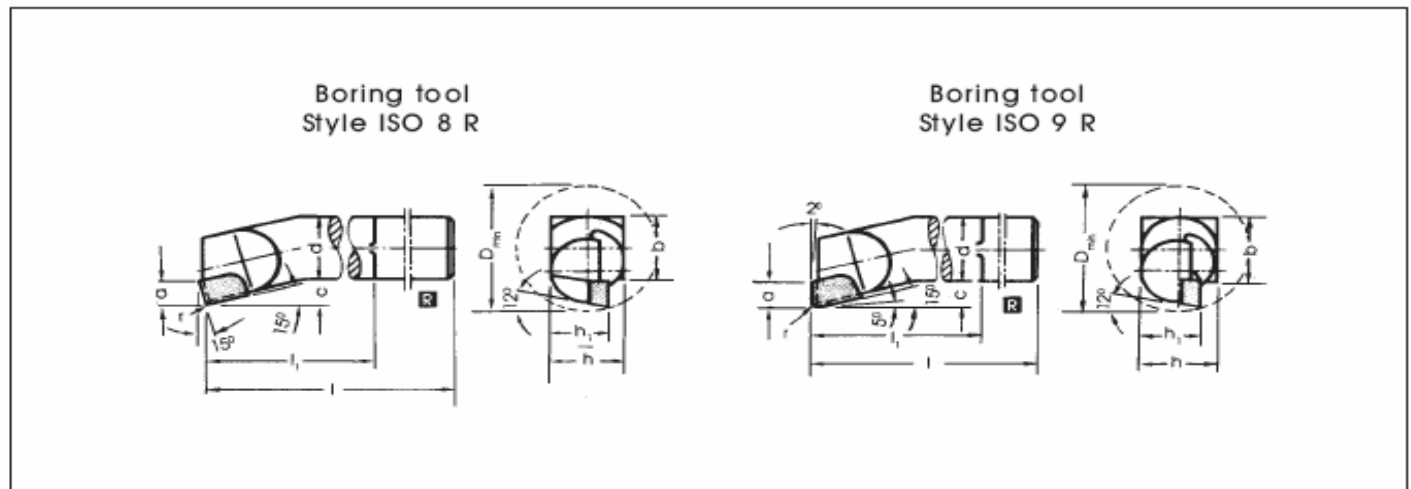

Shank Size	Dimensions in mm								Tip used
	h/b/d	h <sub>1</sub>	l	l <sub>1</sub>	c	a	r	D <sub>min</sub>	
<b>Style ISO 8 R</b>									
0808	8	5.9	125	40	3	3.8	0.4	14	A 6
1010	10	7.9	150	50	4	3.8	0.4	18	A 6
1212	12	9.1	180	63	5	4.8	0.4	21	A 8
1616	16	12.3	210	80	6	5.8	0.4	27	A10
2020	20	15.5	250	100	8	7.7	0.4	34	A12
2525	25	19.5	300	125	10	9.6	0.8	43	A16
3232	32	25.1	355	160	12	11.6	0.8	52	A20
Ø 8	8	5.9	125	-	3	3.8	0.4	14	A 6
Ø 10	10	7.5	150	-	4	3.8	0.4	18	A 6
Ø 12	12	9.1	180	-	5	4.8	0.4	21	A 8
Ø 16	16	12.3	210	-	6	5.8	0.4	27	A10
Ø 20	20	15.5	250	-	8	7.7	0.4	34	A12
Ø 25	25	19.5	300	-	10	9.6	0.8	43	A16
Ø 32	32	25.1	355	-	12	11.6	0.8	52	A20
<b>Style ISO 9 R</b>									
0808	8	5.9	125	40	3	3.5	0.4	14	A 6
1010	10	7.5	150	50	4	3.5	0.4	18	A 6
1212	12	9.1	180	63	5	4.4	0.4	21	A 8
1616	16	12.3	210	80	6	5.3	0.4	27	A10
2020	20	15.5	250	100	8	7.1	0.4	34	A12
2525	25	19.5	300	125	10	8.9	0.8	43	A16
3232	32	25.1	355	160	12	10.7	0.8	52	A20
Ø 8	8	5.9	125	-	3	3.5	0.4	14	A 6
Ø 10	10	7.5	150	-	4	3.5	0.4	18	A 6
Ø 12	12	9.1	180	-	5	4.4	0.4	21	A 8
Ø 16	16	12.3	210	-	6	5.3	0.4	27	A10
Ø 20	20	15.5	250	-	8	7.1	0.4	34	A12
Ø 25	25	19.5	300	-	10	8.9	0.8	43	A16
Ø 32	32	25.1	355	-	12	10.7	0.8	52	A20

**Note :** The above Tools are supplied in ISO grades P30 & K20. Specials can be made to order. Please write to us with drawings.

Unless otherwise specified the above tools are supplied with :  
Rake angle : 10°

**HOW TO ORDER :** Please specify shank size, hand and grade.



# TTEC Hardmetal Tipped Tools

**Straight round nose tool  
Style SRNT**

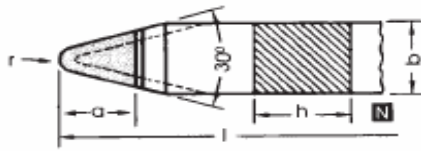

**Cranked round nose tool  
Style CRNT**

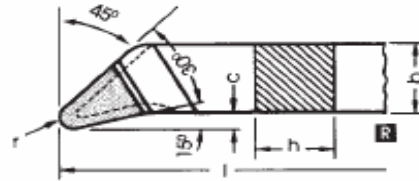

Shank Size

Dimensions in mm

Tip used

Shank Size	h	b	l	c	a	r	Tip used
<b>Style SRNT</b>							
1010	10	10	90	-	12	1.0	G 8
1212	12	12	100	-	14	1.5	G10
1616	16	16	110	-	17	2.5	G12
2020	20	20	125	-	20	3.5	G16
2525	25	25	140	-	23	4.5	G20
3232	32	32	170	-	27	6.0	G25
4040	40	40	200	-	32	8.0	G30
1610	16	10	110	-	12	1.0	G 8
2012	20	12	125	-	14	1.5	G10
2516	25	16	140	-	17	2.5	G12
3220	32	20	170	-	20	3.5	G16
4025	40	25	200	-	23	4.5	G20
5032	50	32	240	-	27	6.0	G25
<b>Style CRNT</b>							
1010	10	10	90	3.0	-	1.0	G 8
1212	12	12	100	3.5	-	1.5	G10
1616	16	16	110	4.5	-	2.5	G12
2020	20	20	125	4.8	-	3.5	G16
2525	25	25	140	5.5	-	4.5	G20
3232	32	32	170	6.3	-	6.0	G25
4040	40	40	200	7.0	-	8.0	G30
1610	16	10	110	3.0	-	1.0	G 8
2012	20	12	125	3.5	-	1.5	G10
2516	25	16	140	4.5	-	2.5	G12
3220	32	20	170	4.8	-	3.5	G16
4025	40	25	200	5.5	-	4.5	G20
5032	50	32	240	6.3	-	6.0	G25

**Note :** The above Tools are supplied in ISO grades P30 & K20. Specials can be made to order. Please write to us with drawings.

Unless otherwise specified the above tools are supplied with :  
Rake angle : 5°

**HOW TO ORDER :** Please specify shank size, hand and grade.

# TTEC Hardmetal Tipped Tools

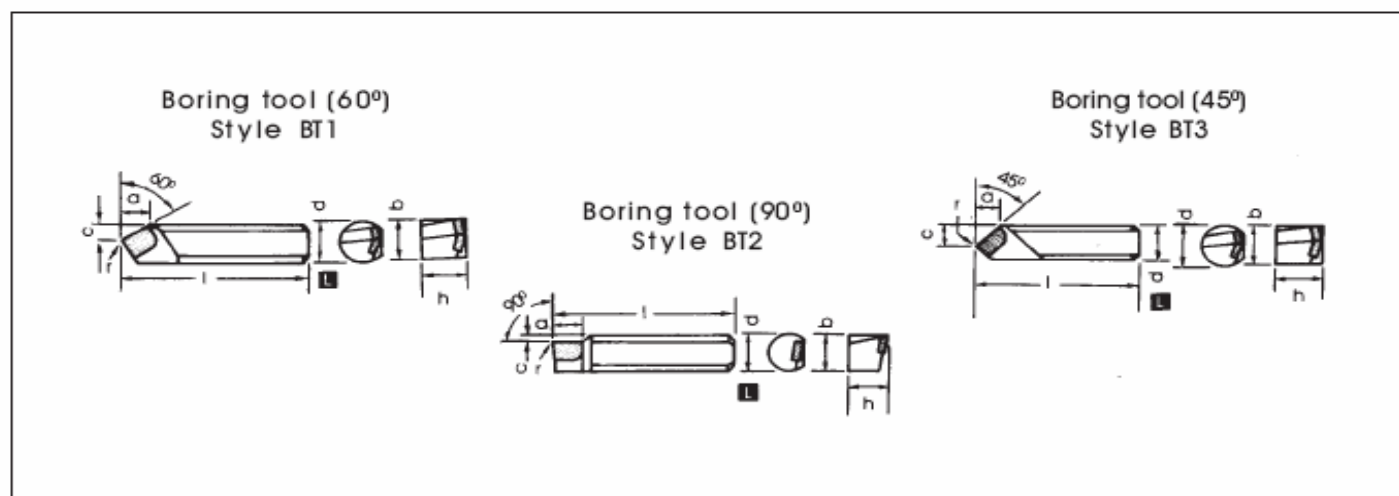

Shank Size	Dimensions in mm						Tip used
	b/d	h	l	c	a	r	
<b>Style BT 1</b>							
∅ 10	10	8.5	50	5.0	6.5	0.4	B 8
∅ 12	12	10.5	60	6.0	8.5	0.4	B 10
∅ 16	16	14.0	90	8.0	10.0	0.8	B 12
∅ 20	20	17.0	120	10.0	13.5	0.8	B 16
1010	10	-	50	4.5	6.5	0.4	B 8
1212	12	-	60	5.5	8.5	0.4	B 10
1616	16	-	90	7.5	10.0	0.8	B 12
∅ 3/8"	3/8"	8.3	50	4.3	6.5	0.5	B 8
∅ 1/2"	1/2"	11.1	60	5.9	8.5	0.5	B 10
∅ 3/4"	3/4"	16.0	120	8.9	13.5	0.8	B 16
<b>Style BT 2</b>							
∅ 10	10	8.5	50	0.4	8.0	0.4	B 8
∅ 12	12	10.5	60	0.4	10.0	0.4	B 10
∅ 16	16	14.0	90	0.4	12.0	0.8	B 12
∅ 20	20	17.0	120	0.5	16.0	0.8	B 16
∅ 3/8"	3/8"	8.3	50	0.4	8.0	0.5	B 8
∅ 1/2"	1/2"	11.1	60	0.4	10.0	0.5	B 10
∅ 5/8"	5/8"	14.0	90	0.4	12.0	0.8	B 12
∅ 3/4"	3/4"	16.0	120	0.5	16.0	0.8	B 16
3/8" Sq.	3/8"	-	50	0.4	8.0	0.5	B 8
1/2 Sq.	1/2"	-	60	0.4	10.0	0.5	B 10
<b>Style BT 3</b>							
∅ 10	10	9.2	8	50	6.5	5.5	0.5 B 8
∅ 12	12	11.2	9.2	60	7.5	7.5	0.5 B 10
∅ 16	16	14.5	12.9	90	9.5	8.5	0.8 B 12
∅ 3/8"	3/8"	8.7	7.5	63	6.3	5.0	0.5 B 8
∅ 1/2"	1/2"	11.9	9.9	76	7.9	7.0	0.5 B 10
∅ 5/8"	5/8"	14.3	12.3	89	9.2	8.0	0.8 B 12
∅ 3/4"	3/4"	16.7	14.7	120	11.9	11.0	0.8 B 16

Note : The above Tools are supplied in ISO grades P30 & K20. Specials can be made to order. Please write to us with drawings.

Unless otherwise specified the above tools are supplied with :  
Rake angle : 10°

HOW TO ORDER : Please specify shank size, hand and grade.

# TTEC Hardmetal Tipped Tools

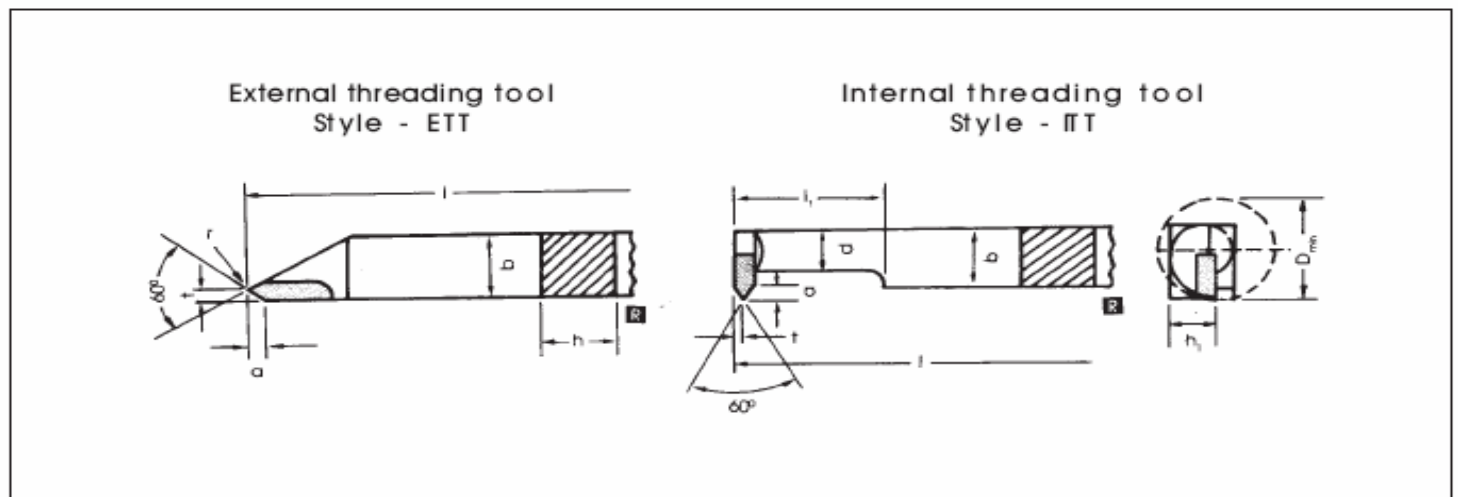

Shank Size	Dimensions in mm									
	h/b	l	l <sub>1</sub>	h <sub>1</sub>	a	d	r	t	D <sub>min</sub>	Tip used
<b>Style ETT</b>										
1616	16	110	-	-	3.5	-	0.1	3	-	E6
2020	20	125	-	-	4.6	-	0.1	4	-	E8
2525	25	140	-	-	5.8	-	0.2	5	-	E10
<b>Style ITT</b>										
1616	16	140	30	7.8	1.7	10	-	1.0	15	E6
2020	20	160	40	9.8	1.7	15	-	1.0	20	E8
2525	25	180	50	12.3	2.0	18	-	1.2	25	E10
3232	32	200	60	15.7	2.0	21	-	1.2	30	E12

**Note :** The above Tools are supplied in ISO grades P30 & K20. Specials can be made to order. Please write to us with drawings.

Unless otherwise specified the above tools are supplied with :  
Rake angle : 0°

**HOW TO ORDER :** Please specify shank size, hand and grade.