

A world map with a blue grid pattern. The country of China is highlighted in a solid red color. A dark blue horizontal bar is overlaid on the map, containing the title text.

Market Access to China

By Jane Peng
TÜV Rheinland Taiwan Ltd.

140
anniversary
1872 - 2012

 TÜVRheinland®
Precisely Right.

Content Overview

- General Information/Introduction of China Authorities
- Introduction of China Approvals / 4 major mandatory approvals
 - - CCC approvals
 - - RTA approval (SRRC)
 - - NAL approval
 - - CEL approval
- News update
- TÜV Rheinland's One-Stop ful services

China Authorities

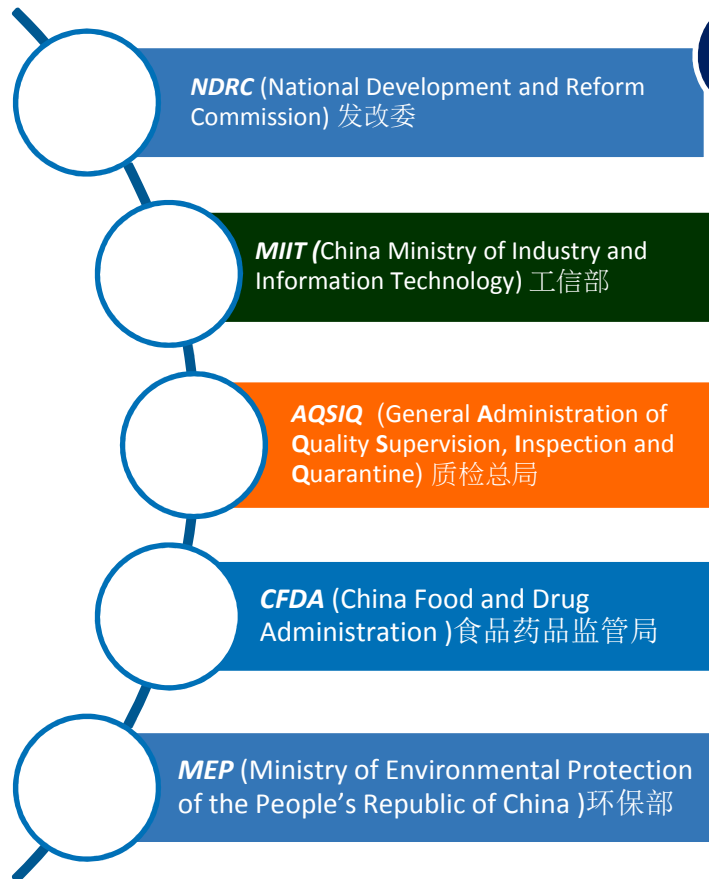

MIIT

TAB (Telecom Administration Bureau) 电信管理局
 TENAA (Telecommunication Equipment Certification Center) 电信设备认证中心

Radio Administration Bureau 无线电管理局
 SRRC (The State Radio Regulation Center) 国家无线电监测中心

AQSIQ

1. Direct Affiliates of AQSIQ (15) 直属单位 (CNAS)
 2. Associations attached to AQSIQ(10) 挂靠单位 (CCAA, CCIC, CICHK)

1. CIQs directly under AQSIQ (35) 35个出入境检验检疫局
 2. Provincial Bureaus of Quality and Technical Supervision (31) 31个省质量技术监督局

AQSIQ

CNCA (Certification and Accreditation Administration) 认监委
 1. Certification bodies 认证机构
 2. National test laboratories 检测机构

SAC(Standardization Administration of China) 标准委

China Authorities for CCC



Management Agencies

- **CQC (Fullest , biggest)**
- CCAP (Vehicle & Spare parts)
- CSP (Security Products)
- CCCF (Fire Products)
- CCLC (Toys)
- **CQM (Decorating materials* &LVD)**
- **ISCCC (WLAN&IT products)***
- **CESI (AV products)#**
- **CTC (Low voltage devices)#**

- AQSIQ: Rule maker
- CNCA: Rule maker
- SAC: Standard maker
- CNAS: lab qualification
- CCAA: CCC practitioner's qualification, including FI Auditor
- CIQs: Market Surveillance



13 Designed Certification Bodies
(By products)

152 Designed Test Laboratories
(By products and manufacture/factory locations)

Contract

* : 2 DCBs with new scope in 2012
: 2 new DCBs added in 2012
Red: DCBs for main TUV NA products

- 00101 CESI
- 00401 Ceprei
- 00501 CVC
- 02101 SET
- 06901 BJCIQ



Designed Test Lab
t_updated 201307

China Approvals



China Approvals



M for Mandatory

V for voluntary

CCC: China Compulsory Certificate

SRRC: State Radio Regulation Center

NAL: Network Access License

CEL: China Energy Label

SEL: Special Equipment License

CFDA: China Food and Drug Administration

CQC: China Quality Certificate Center

CEC: China Environmental Labeling Certificate

Tips :

Products should meet multi-requirements and apply multi-certificate if they fall in different scopes.

Eg. Laptop with BT and telecom port, should meet the requirements of CCC, SRRC, NAL and CEL at the same time.

*** TÜV Rhainland Greater China's focus and expertise.**

4 major mandatory approvals: CCC, SRRC, NAL, CEL

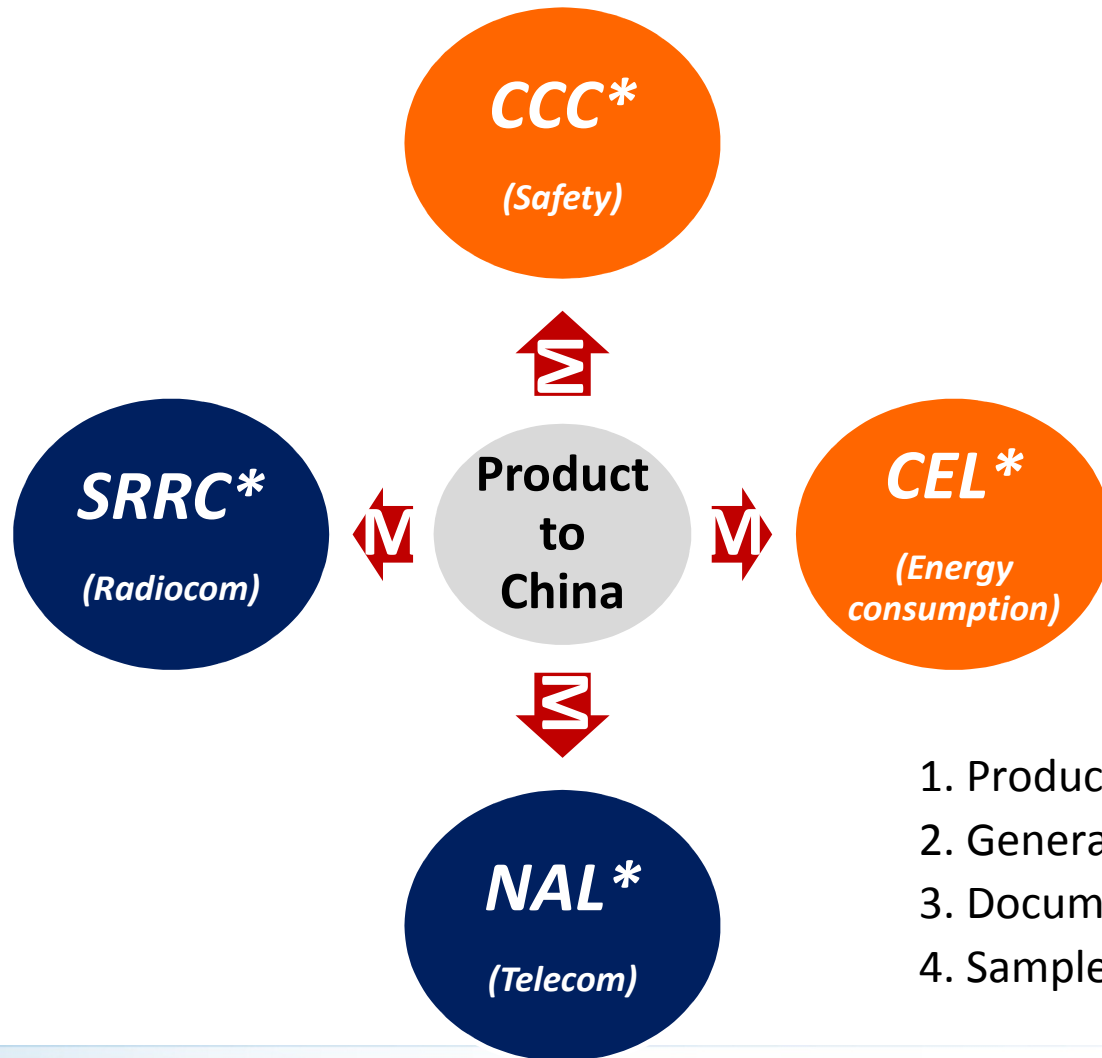

1. Product Scope
2. General Procedure
3. Document requirements
4. Sample of certificate

CCC Approvals



China Compulsory Certificate

Type Testing



Initial FI



Follow up FI

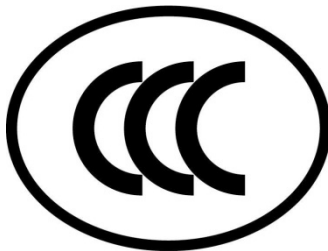

CCC Approvals- Product Scope

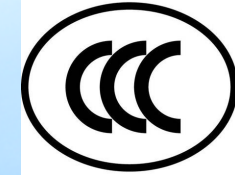

Descriptions and Definitions for Compulsory Product Certificate Catalogue: 20 Categories, 149 types

CNCA Announcement No. 30th , 2012 issued by CNCA &
Joint Announcement No. 52, 2013 issued by AQSIQ, CFDA and CNCA

▪ Electric Products (11 Categories,103 types)

1. (01) Electrical wires and cables (4 types)
2. (02) Switches for circuits , installation protective and connection devices (6 types)
3. (03) Low-voltage electrical apparatus (9 types)
4. (04) Small power motor (1 type)
5. (05) Power Tools (16 types)
6. (06) Welding Machine (15)
7. (07) Household products(18 types)
8. (08) AV products(12 types)
9. (09) ITE products(11 types)
10. (10) Luminaries (2 types)
11. (16) Telecom terminal products(9 types)

▪ Non-Electric Products (9 Categories,46 types)

1. (11) Motor vehicles and safety parts (16 types)
2. (12) Motor vehicle tyres (3 types)
3. (13) Safety glasses (3 types)
4. (14) Agricultural machinery (2 types)
5. (18) Fire protection equipment (7 types)
6. (19) Security and Protection equipment(5 types)
7. (20) WLAN product (1 type)
8. (21) Decoration products (3 types)
9. (22) Toys (6 types)



CCC Catalogue
2012

CCC Approvals - Product Scope – Main products

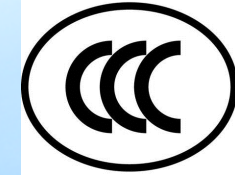

08 Audio Video Product

- 1) 0801 Speaker(under 500W)
- 2) 0802 Audio power amplifier
- 3) 0804 Radio receivers
- 4) 0805 Recorders, players, dealers for audio and video with kinds of carrier media
- 5) 0806 Combined products of above 5 types
- 6) 0807 Power adapters for audio/video products
- 7) 0808 Color television receivers with kinds of display Types
- 8) 0809 Monitors(not including television receivers for automobiles)
- 9) 0811 Picture/display tubes
- 10) 0812 Video recorders
- 11) 0813 Electronic organs
- 12) 0814 Antenna amplifiers

09 Information Technology Equipment

- 1) 0901 Personal Computer
- 2) 0902 Portable personal computer
- 3) 0903 Display units connected with computer; projector displays
- 4) 0904 Printers connected with computer, plotter
- 5) 0905 Multiplying printer & coping machines
- 6) 0906 Scanner
- 7) 0907 Switching power supply units for computer, adapters, chargers
- 8) 0908 Computer game players
- 9) 0909 Learning Machines
- 10) 0910 Duplicators
- 11) 0911 Servers
- 12) 0913 Cashier

16 Telecom Terminal Equipment

- 1) 1601 Modem(Voice-band Modem, base-band modem, DSL modem ,including card)
- 2) 1602 Facsimile machine (Fax Machine, Voice/ Fax Card, Fax machine with multi-functions)
- 3) 1603 Fixed telephone terminal
- 4) 1604 Cordless telephone terminal (Analogue cordless telephone set, digital cordless telephone set)
- 5) 1605 Key-Phone system(Key-phone system, Telephone Conference Exchange)
- 6) 1606 Mobile Terminal
- 7) 1607 ISDN Terminal (NT1,NT1+ 、 TA (including card)
- 8) 1608 Data Terminal(Including card)
- 9) 1609 Multimedia terminal (video phone, conference system, VOD terminal, other multimedia terminal)

CCC Approvals- How to define product in scope ?

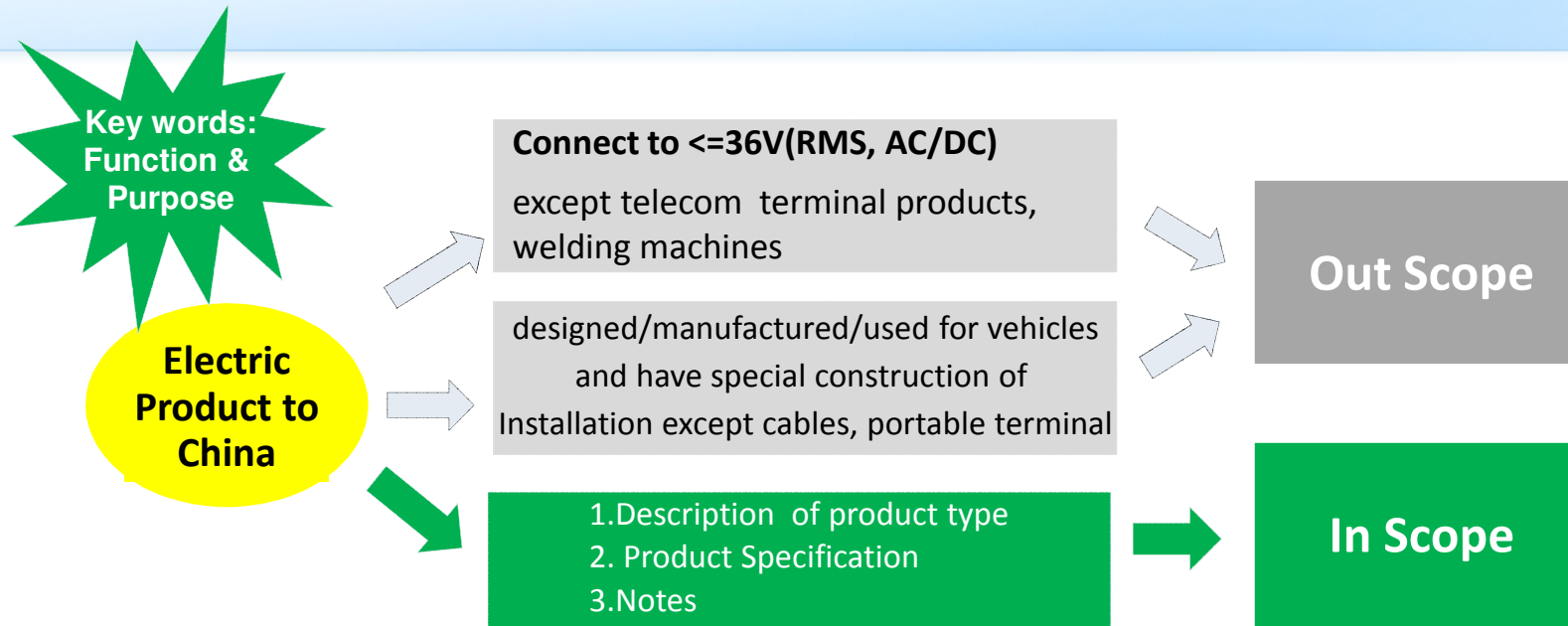

CCC Approvals- Product Scope – EXEMPTION!

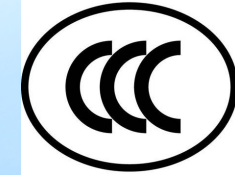

Those products are in the scope but may not need to apply for CCC mark.

Product to China

1. Products imported for scientific research and test purposes
2. Product parts imported for technology examination and production line introduction
3. Products imported for end users' repair service directly
4. Equipment/parts imported necessary to form a manufacturing production line, but the office equipment are not excluded
5. Products imported for commercial exhibits only, not for selling
6. Products imported temporarily and will be returned and shipped out of China, including the products for exhibitions;
7. Product parts imported in the regular trading method but for the purpose to export the whole system;
8. Product parts imported in the way of processing materials supplied by clients but for the purpose to export the whole system.

CCC Approvals - General Procedure

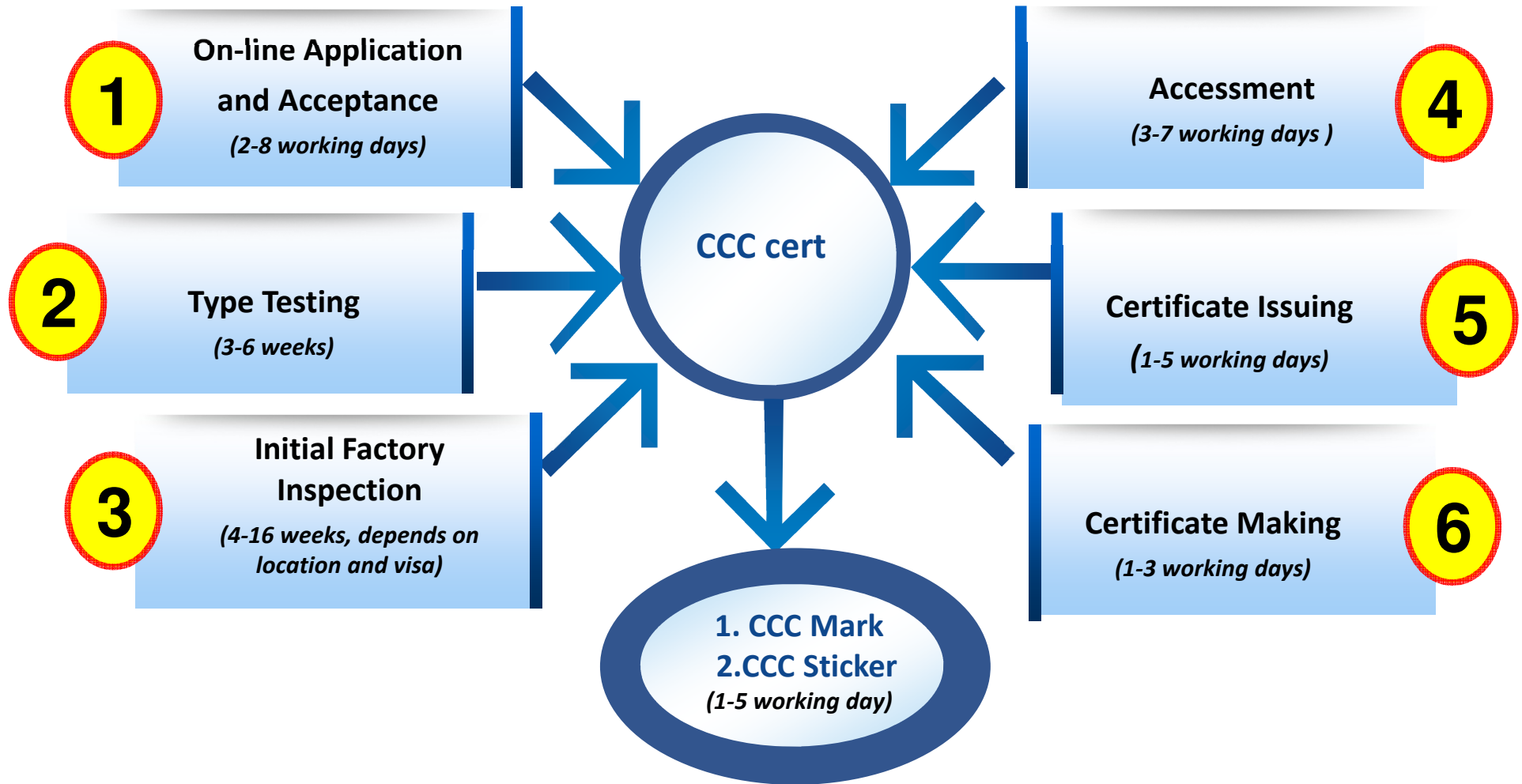
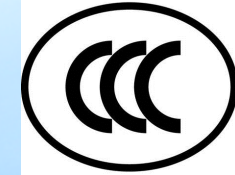

CCC Approvals – Tips

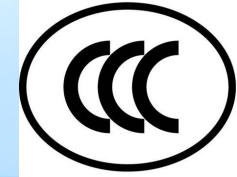

- Document require: [strict requirement about documentation.](#)
- Samples: [2-3](#) sets (or 1-2 sample for project based on CB)
- Voltage and Frequency: AC 220V / 50Hz
- Factory Inspection: according to CCC Implementation rules (10 articles)
- Factory follow up inspection
- Technical Requirement: China national standards (GB) harmonized with IEC standards.
- Requirements for accepting of CB report
- CCC mark permission: 1 year validity, need to be renewed annually.

CCC Approvals- Sample of Certificate (CQC)

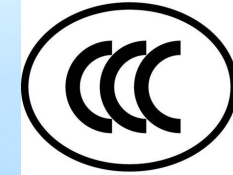

 中国国家强制性产品认证证书

证书编号: [REDACTED]

委托人名称、地址
[REDACTED]

生产者(制造商)名称、地址
[REDACTED]

生产企业名称、地址
[REDACTED]

产品名称和系列、规格、型号
可移动式白炽灯具(台灯/落地灯, II类, IP20, F标记, E27)
见附件: AC 220-240V, 50/60Hz.

产品标准和技术要求
GB7000.204-2008, GB7000.1-2007

上述产品符合强制性产品认证实施规则
CNCA-01C-022:2007的要求, 转发此证。

发证日期: 2011年12月13日 有效期至: 2016年12月13日

证书有效期内本证书的有效性依据发证机构的定期监督获得保持。
本证书的相关信息可通过国家认监委网站www.cnca.gov.cn查询

 主任: 
中国质量认证中心
中国·北京·前门东大街188号9区 100070
<http://www.cqc.com.cn>



Q 0482201

 CERTIFICATE FOR CHINA COMPULSORY PRODUCT CERTIFICATION

No. : [REDACTED]

NAME AND ADDRESS OF THE APPLICANT
[REDACTED]

NAME AND ADDRESS OF THE MANUFACTURER
[REDACTED]

NAME AND ADDRESS OF THE FACTORY
[REDACTED]

NAME, MODEL AND SPECIFICATION
Portable Luminaires For Incandescent Lamps (Table Standing
Luminaire / Floor Standing Luminaire, Class II, IP20, F Mark, E27)
See Appendix: AC 220-240V, 50/60Hz.

THE STANDARDS AND TECHNICAL REQUIREMENTS FOR THE PRODUCTS
GB7000.204-2008, GB7000.1-2007

This is to certify that the above mentioned products have met the
requirements of implementation rules for compulsory certification (NEP
NO. CNCA-01C-022:2007).

Date of issue: Dec.13,2011 Date of expiry: Dec.13,2016

Validity of this certificate is subject to positive result of the regular
follow up inspection by issuing certification body until the expiry date.
This certificate can be verified through CNCA's website: www.cnca.gov.cn

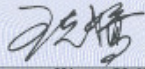
 President: 
Wang Kejiao
CHINA QUALITY CERTIFICATION CENTRE
Section 9.No.188,Nanshuan Xilu, Beijing 100070 P.R.China
<http://www.cqc.com.cn>



Q 0482201

Certificate is valid
for 5 years

CCC Approvals- CCC Mark Permission

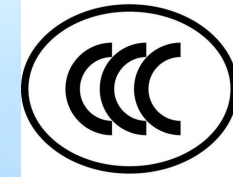

CCC Mark Printing/Impressing Permission (Non-standard CCC Mark)

中国强制性产品认证印刷 / 模压标志批准书
 Permission of Printing/Impressing China Compulsory Product Certification Mark
 No. FZ2012027015

兹批准本通知书申请人在由下列生产厂为其生产的产品本体上使用烙印方式加施强制性产品标志。
 WE HEREBY AUTHORIZE THE APPLICANT IN THE FACTORY TO ADOPT STAMPED USING COMPULSORY CERTIFICATION MARK. THE APPROVED DESIGN OF MARKS MUST BE SHOWN ON THE BODY OF PRODUCTS.

申请人:
 APPLICANT:
 制造商:
 MANUFACTURER:
 生产厂:
 FACTORY:
 证书号:
 CERTIFICATE NO:

批准图案 (见附页)
 APPROVED PATTERN (SEE ATTACHMENT)
 有效日期从 2012年 6月 2日 至 2013年 6月 1日
 VALID DATE FROM Jun. 2, 2012 TO Jun. 1, 2013
 发证日期: 2012年 06月 02日
 APPLICATION DATE: Jun. 02, 2012



 中国国家认证认可监督管理委员会
 Certification and Accreditation Administration
 of the People's Republic of China

地址: 中国 北京 朝阳区朝阳门外大街甲 10 号中认大厦 5 层 邮编: 100020
 ADD: 5F A10, Chaowai Street, Chaoyang District, Beijing, P. R. China POSTCODE, 100020
 电话 TEL: +86-10-65991234 传真 FAX: +86-10-65994089/65994173/65991234 http://www.cnca.gov.cn

0430989

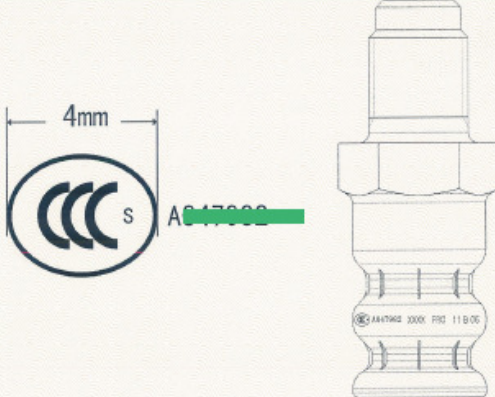

中国强制性产品认证印刷 / 模压标志批准书
 Permission of Printing/Impressing China Compulsory Product Certification Mark
 附页 No. FZ2012027015

此批准书批准范围仅为CCC认证证书涵盖内容, 批复图案中无关CCC证书的内容不在批准范围内, 请认证企业遵照相关法律法规执行。《中国强制性产品认证印刷/模压标志批准书》有效期内, 如所涉CCC认证证书失效, 则批准书同时失效。
 IT IS ONLY THE AREAS COVERED BY CCC CERTIFICATE ARE AUTHORIZED. THE IRRELEVANT CONTENT OF THE APPROVED DESIGNS CAN NOT BE AUTHORIZED. THE CERTIFIED ORGANIZATIONS SHOULD BE SUBJECT TO THE RELEVANT LAWS AND REGULATIONS. DURING THE VALID PERIOD OF "PERMISSION OF PRINTING/IMPRESSING CHINA COMPULSORY CERTIFICATION MARK", IF THE RELEVANT CCC CERTIFICATE EXPIRES, THE APPROVAL AUTOMATICALLY EXPIRES.

 4mm
 CCC S A6-17000

地址: 中国 北京 朝阳区朝阳门外大街甲 10 号中认大厦 5 层 邮编: 100020
 ADD: 5F A10, Chaowai Street, Chaoyang District, Beijing, P. R. China POSTCODE, 100020
 电话 TEL: +86-10-65991234 传真 FAX: +86-10-65994089/65994173/65991234 http://www.cnca.gov.cn

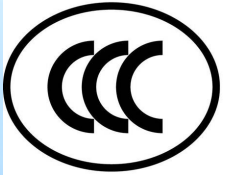
CCC Approvals- CCC Mark Permission



- Sticker (Standard CCC Mark): Purchasing from CCC Mark Distribution On-Site

8mm



45mm



15mm



60mm



30mm

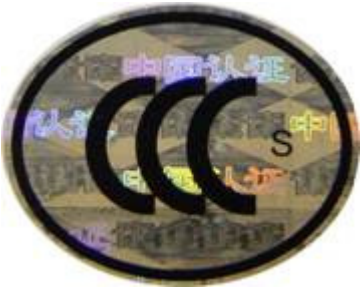

RTA Approval

SRRC Radio Type Approval

无线电发射设备
Radio Transmission Equipment
型号核准证
Type Approval Certificate

Applicant Name: [REDACTED]

根据《中华人民共和国无线电管理条例》，经审查，下列无线电发射设备符合中华人民共和国无线电管理规定和技术标准，其核准代码为：[REDACTED] Certification No.

有效期：五年
Validity

工业和信息化部
(发证机关)
Sealed by Issuing Authority
2010年05月18日
Year Month Date

编号：[REDACTED]
Number

设备名称：[REDACTED]
Equipment Name

设备型号：[REDACTED]
Equipment Type

主要功能：[REDACTED]
Main Functions

调制方式：[REDACTED]
Modulation Mode

主要技术参数及其指标值：
Main Technical Parameters

频率范围：[REDACTED]
Frequency Range

频率容限：[REDACTED]
Frequency Tolerance

占用带宽：[REDACTED]
Occupied Bandwidth

发射功率：[REDACTED]
Transmitting Power

杂散发射限值：[REDACTED]
Spurious Emission Limits

工业和信息化部
(核准单位)
Sealed by Approval Authority
2010年05月18日
Year Month Date

CMIIT ID: XXXXYZNNNN



RTA Approval - Scope

CMIIT ID: XXXYZNNNN

Radio Transmission Equipment

- 1) Public mobile communication devices
- 2) Wireless Access System
- 3) Special Network Devices
- 4) Microwave equipment
- 5) Satellite equipment
- 6) Broadcast equipment
- 7) 2.4GHz/5.8GHz wireless devices
- 8) Short range wireless devices
- 9) Radar
- 10) Other radio transmitters
- 11) For the equipment out of above scope, can be referred to above

Telephone
(GSM, 3G)



WLAN
(IEEE802.11)



Bluetooth, Zigbee
(IEEE802.15)



Low power short range wireless Devices



ZigBee™



RTA Approval – Procedure

Leadtime: 6 weeks

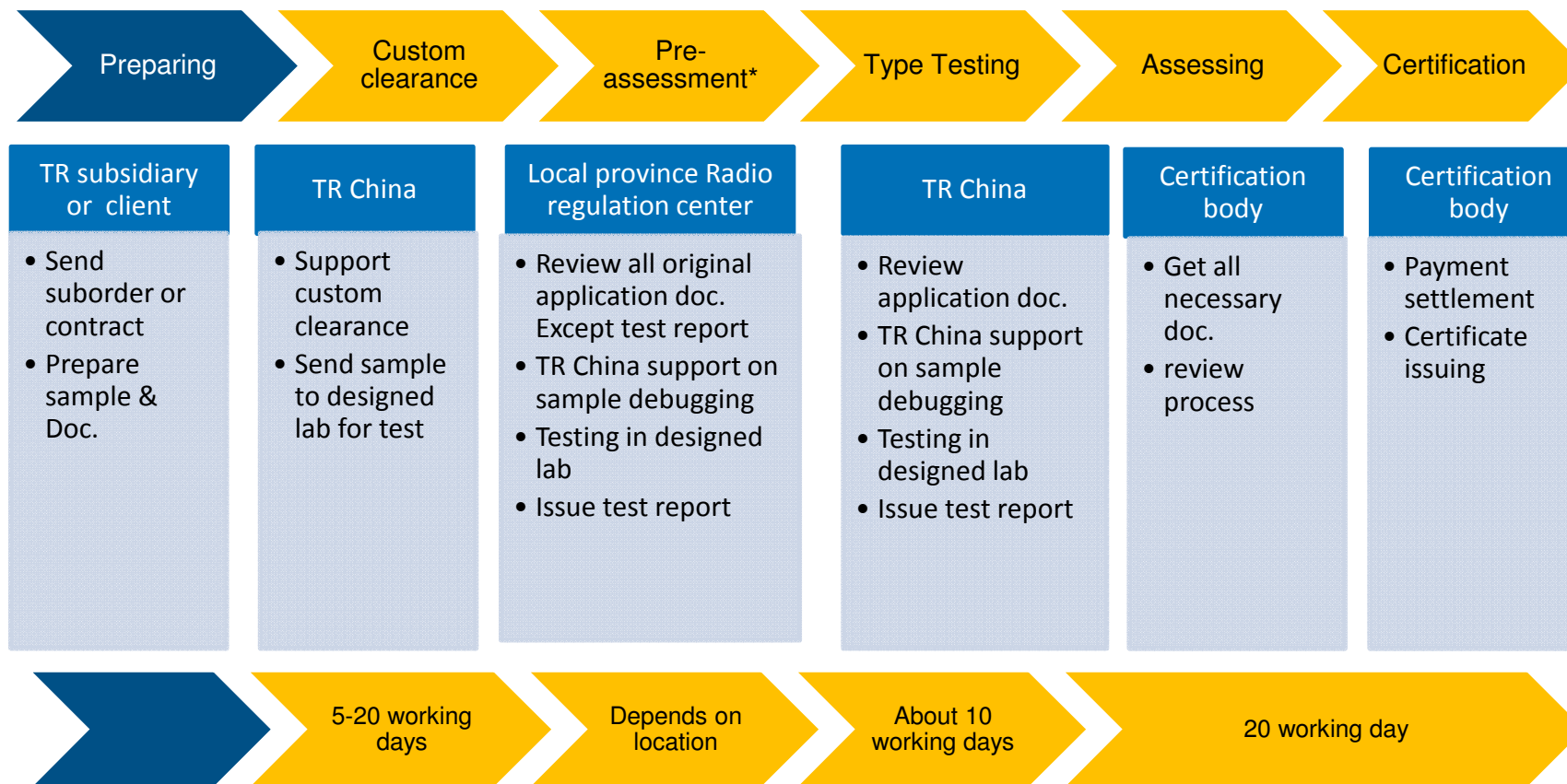

*** Pre-assessment is necessary when applicant located in mainland China (Guangdong province is exemption)**

RTA Approval – Tips

- **Leadtime:** 6-8 weeks (2 weeks for test + 6 weeks for approval) based on full documents and samples
- **Sample required: 3-5 conducted samples**
- **Technical requirement:**
 - 信部无[2002]277号 Notice for using frequency range of **5.8GHz**
 - 信部无[2002]353号 Notice for adjusting limitation of transmitting power for frequency range of **2,4GHz** and relative issues (**Bluetooth** included)
 - 信部无[2005]423号 Technical requirement for **low power(short range)** wireless devices...
- **Label with necessary information**
- **Approval is based on model name, regardless the wireless module**
- **Product Certificate is valid for 5 years but can be prolonged 3 years for whole product, and 1 year validity can be prolonged 1 year for module.**

RTA approval – Cert sample

无线电发射设备
Radio Transmission Equipment
型号核准证
Type Approval Certificate

Applicant Name: [REDACTED]

根据《中华人民共和国无线电管理条例》
In accordance with the provisions on the Radio
Regulations of the People's Republic of China, the following
符合中华人民共和国无线电管理规定和
radio transmission equipment, after examination, conforms
技术标准, 其核准代码为: Certification No. [REDACTED]
to the provisions with its CMIIT ID:

有效期: 五年
Validity

(发证机关)
Sealed by issuing authority
2010年05月18日
Year Month Date

编号: [REDACTED]
Number

设备名称: [REDACTED]
Equipment Name

设备型号: [REDACTED]
Equipment Type

主要功能: [REDACTED]
Main Functions

调制方式: [REDACTED]
Modulation Mode

主要技术参数及其指标值:
Main Technical Parameters

频率范围: [REDACTED]
Frequency Range

频率容限: [REDACTED]
Frequency Tolerance

占用带宽: [REDACTED]
Occupied Bandwidth

发射功率: [REDACTED]
Transmitting Power

杂散发射限值: [REDACTED]
Spurious Emission Limits

(核发单位章)
Sealed by issuing authority
2010年05月18日
Year Month Date

Certificate is valid for 5 years

NAL Approval

Network Access License

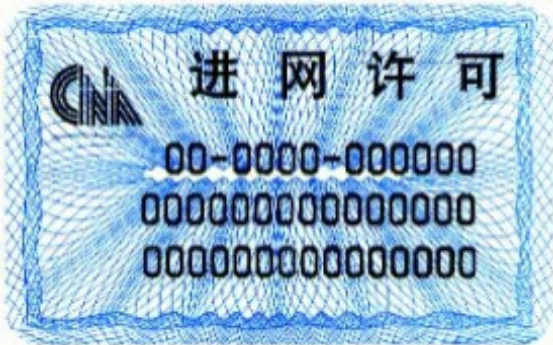

NAL Approval - Scope

Telecom Equipment

- 1) Telephone
- 2) Mobile Phone
- 3) Radio paging receiver
- 4) Program-controlled switchboard/dispatch device
- 5) Group telephone
- 6) Queue device
- 7) Telephone accessory terminal
- 8) Telephone alarm terminal
- 9) Fax machine
- 10) Modem
- 11) Charge device
- 12) Data telecommunication device
- 13) Audio device
- 14) Message device
- 15) ISDN terminal
- 16) Multimedia terminal
- 17) Mobile telecommunication terminal
- 18) LAN program-controlled switchboard
- 19) Access network system device
- 20) Photo electric telecommunication device
- 21) Data microwave telecommunication system
- 22) Network management device, 112 testing system
- 23) Data cycle device
- 24) Intelligent network device
- 25) Synchronous device

Telephone/
Fax machine



Modem



Mobile Phone
(3G)



Data telecommunication device
(Ethernet Switch)



NAL Approval – Procedure

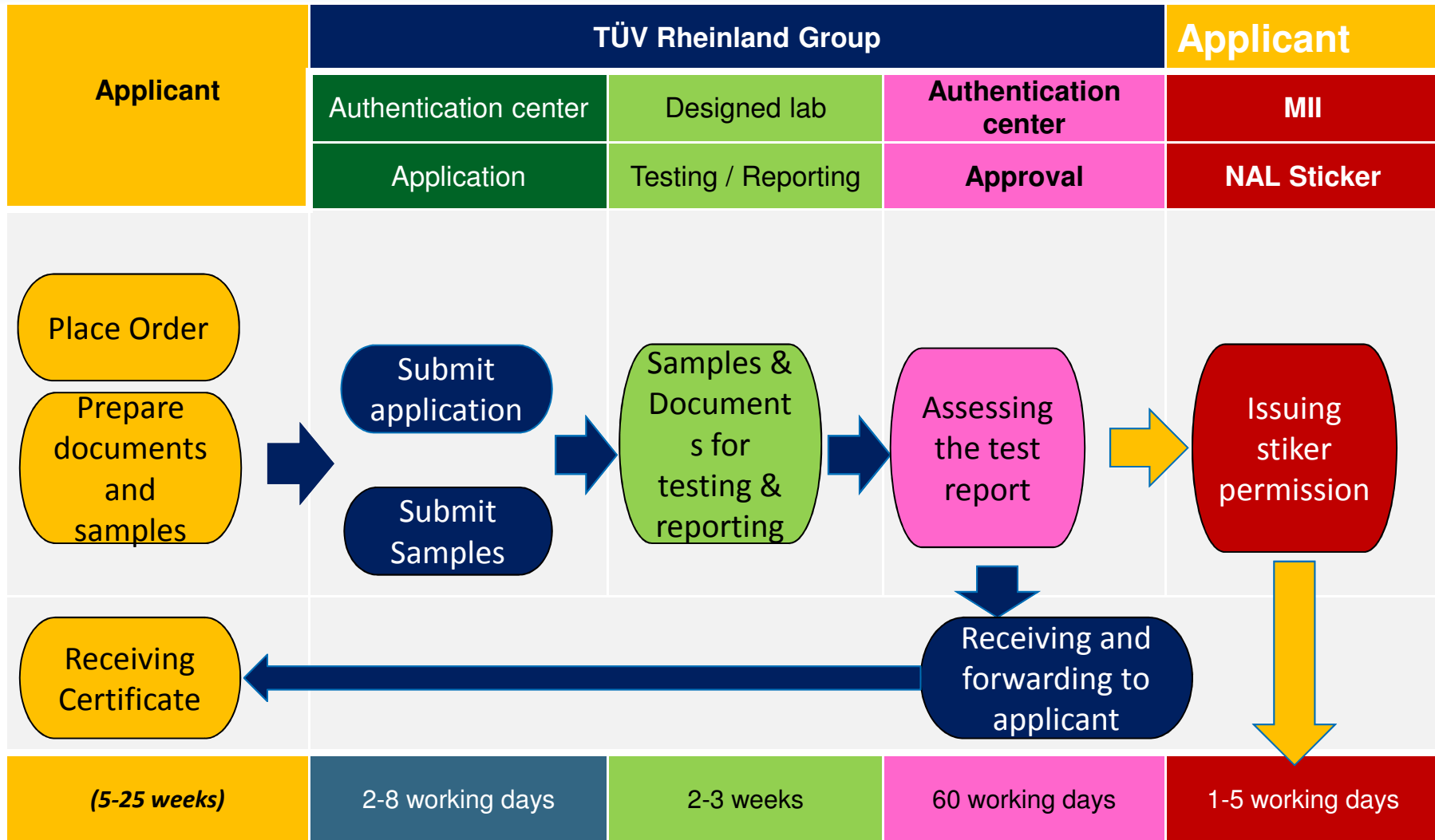

NAL approval – Tips

■ **Leadtime:** 15 -17 weeks (2 -3 weeks for test + 12 weeks for approval) based on full documents and sample

■ **Sample required: depends on product**

■ **Technical requirement:**

- 1. YD/T 1099 Technical requirement for Ethernet LAN Switch 《以太网交换机设备技术规范》
- 2. YD/T 1141 《以太网交换机测试方法》
- 3. YD/T 1627 《以太网交换机设备安全技术要求 》
- 4. YD/T 1628 《以太网交换机设备安全测试方法》
- 4. YD/T 1148 《网络接入服务器技术要求——宽带网络接入服务器》
- 5. YD/T 1260 《基于端口的虚拟局域网（VLAN）技术要请和测试方法》
-

■ **NAL Sticker:**

- All equipment fall NAL catalogue must be affixed with MIIT approval sticker
- Can't be applied by agency

■ **Approval Tips:**

- **Local representative is required**
- 3 year's validity and can be prolonged 3 years for whole product;

NAL approval – Certificate sample

中华人民共和国信息产业部
电信设备进网许可证
Network Access License for Telecommunications Equipment
Ministry of Information Industry, PRC

许可证号:
License No.

经信息产业部审查, 下述电信设备符合进网要求, 准许进入国家电信网使用, 特发此证。
This is to certify that the Ministry of Information Industry has approved, after examination, the use of the following equipment in the national telecommunications network, considering it to be compliant with the requirements for network access.

申请单位:
Applicant
生产企业:
Manufacturer
设备名称:
Equipment Name
设备型号:
Model Number
设备产地:
Origin
备注:
Remarks

发证日期: 年 月 日
Date of Issue Year Month Date
有效期至: 年 月 日
Date of Expiry Year Month Date

CEL approval

China Energy Label

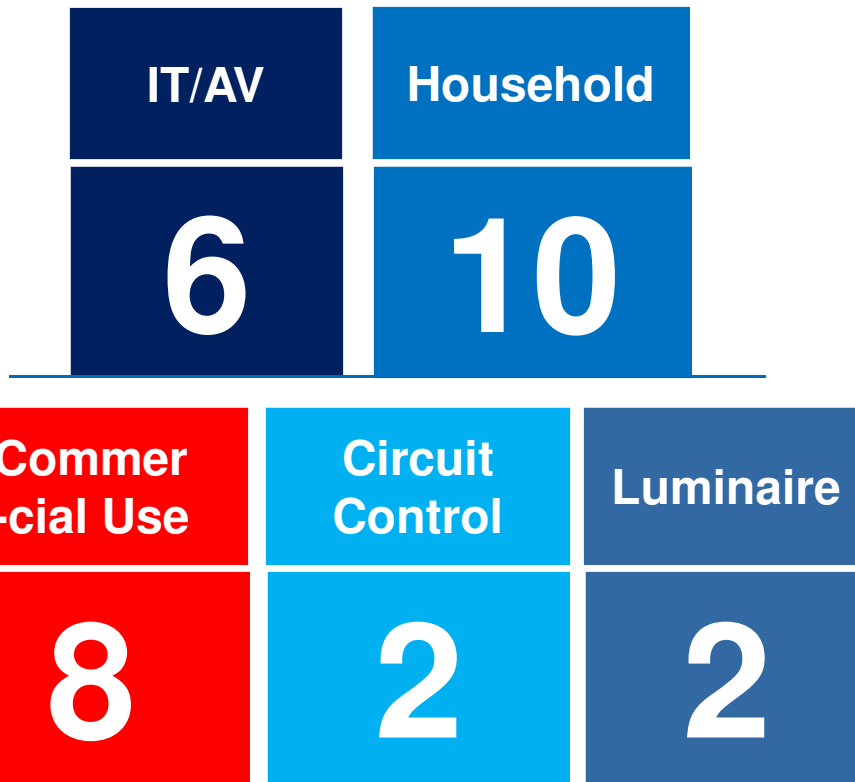

CEL approval

China's energy efficiency labeling management system, known as China Energy Label (CEL), which is mandatory managed by NDRC\AQSIQ\CNCA, is a type of information tag attached to the product or the smallest part of its packaging, indicating the energy efficiency grade, energy consumption and other indices of energy-using products to guide consumers choosing energy-efficient products when they are making purchase decision in market.

Presently, CEL program, since it's established in August, 2004, covers 28 kinds of products announced by NDRC/AQSIQ/CNCA.

And CNIS is only authorized body to implement the registration.

CEL approval - Scope

IT/ AV Product (6 Types)

- 1) Personal Computer
- 2) Set-top boxes
- 3) Printer & Fax
- 4) Panel TVs
- 5) Display
- 6) Copier and Printer



HH Products (10 types)

- 1) Domestic Solar Water Heating Systems
- 2) Microwave Oven
- 3) Room Air Conditions
- 4) Refrigerator
- 5) Auto Electric Cooker
- 6) AC Fans
- 7) Electrical Storage Water Heaters
- 8) Household Induction Cookers
- 9) Domestic water Gas-heater
- 10) Household Electrical Washing Machines



Commercial Products (8 Types)

- 1) Refrigerated Cabinets (Remote Condensing)
- 2) Ventilators
- 3) Displacement Air Compressors
- 4) Variable Speed Room Air Conditioners
- 5) Multi-connected Air-conditions
- 6) Water Chillers
- 7) Three-phase Asynchronous Motors
- 8) Unitary air conditioners



Luminaire (2 Types)

- 1) Self-ballasted Fluorescent Lamps
- 2) High-pressure Sodium Vapour Lamps



Circuit Control (2 Types)

- 1) AC Contactors
- 2) Power Transformers

CEL approval – Flow chart

COMMUNICATION

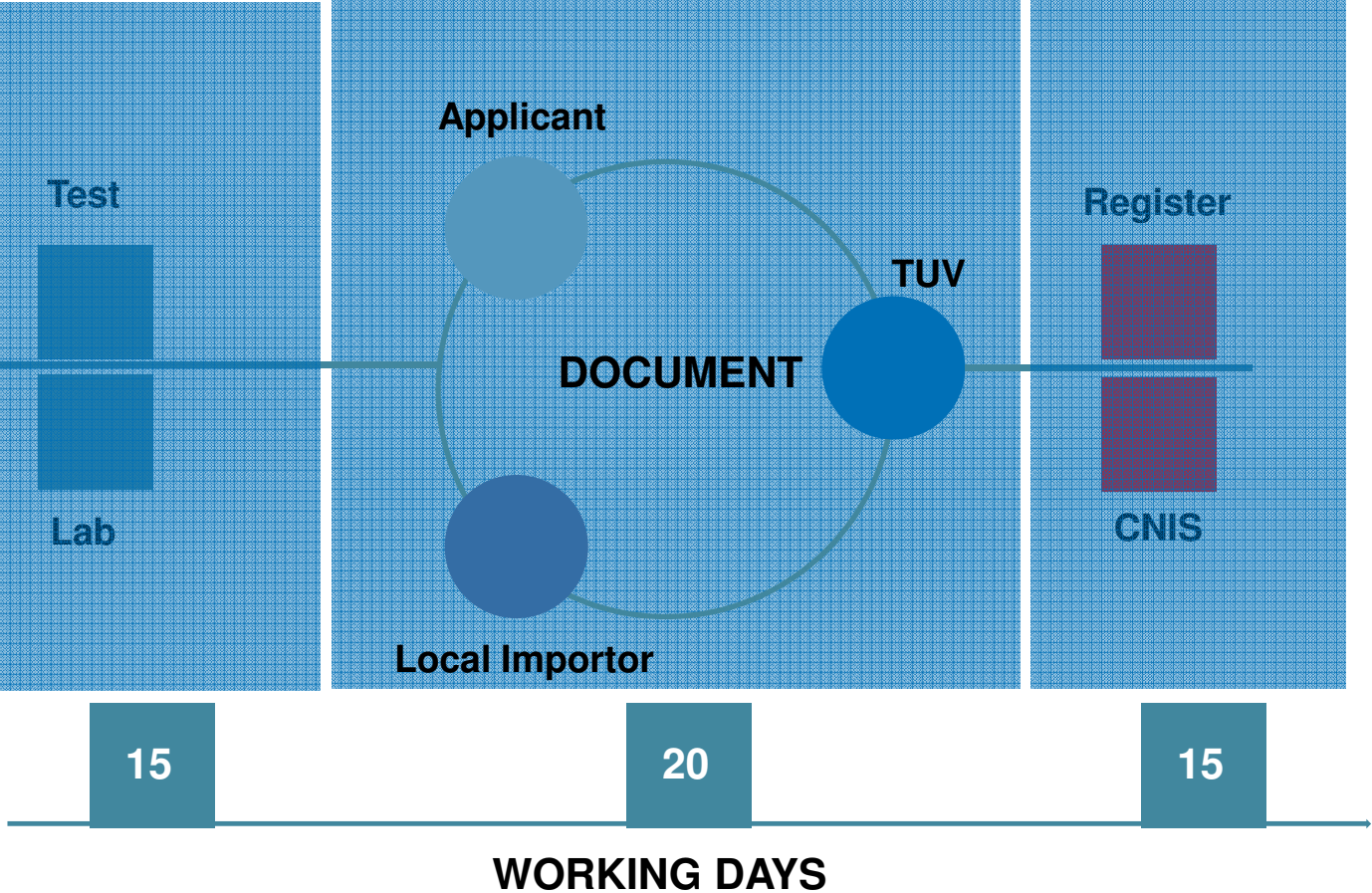

CEL approval - Tips

■ **Leadtime:** 6 weeks(1 week for test + 4 weeks for register)

■ **Sample required:** 1 sample

■ **Technical requirement:**

GB 28380-2012 Minimum allowable values of energy efficiency and energy grade for microcomputers
(IDT Energy star Program requirements for computers, Version 5.0)

GB 25956-2010 Minimum allowable values of energy efficiency and energy grade for printers and fax machines

.....

■ **Label requirement(Various in details based on implementation rules by products)**

- ✓ Name of manufacturer
- ✓ Spec and type of the product
- ✓ Energy efficiency grade
- ✓ Energy consumption/Other performance index
- ✓ Number of applicable GB standard

■ **Registration Tips:**

- Manufacture/Producer in CEL is the brand owner or user who takes legal responsibility of products.
- All designs of energy label, including color, size, characters and so on, must be exact same as the sample of implementation rules
- All CEL register should be finished within 1 month starting from the date used.

News Update – CCC Authorities

DCBs adjusted and added by CNCA No. 35th Announcement, 2012

DCBs

CQM: Add scope of low voltage devices
(1 Type, 0301)



ISCCC: Add scope of ITE products
(11 Types)



CESI: New DCB for AV products
(12 Types)



GQCTC*: New DCB of low voltage devices
(8 Types except 0301 of CQM)



*GQCTC: the only DCB located out of Beijing

DTLs

5 laboratories located in HK are designed in 2013 but no one has any business since it's only for factory located in HK, while HK has no factory indeed.

CNCA plans to have a trial on TW labs for 3 products, time is to be determined

How Labs can be CTLs?
--- DTLs(Authorized by CNCA)
--- CTLs(Contracted with DCBs and approved by CNCA)

News Update – CCC Catalogue

Main CCC Scope Change : Announcement 9th,2007 VS Announcement 30th, 2012
(Principally speaking: only removal, no adding)

Category	Type	Product Name	Version 2007	Version 2012
08 AV	0803	调谐器 Tuners	In	Out
	0810	黑白电视接收机及其它单色的电视接收机 B/W television receivers and other monochrome television receivers	In	Out
	0815	声音和电视信号的电缆分配系统设备与部件 Equipment and components for cable distribution systems of sound and television signals	In	Out
	0816	卫星电视广播接收机 Satellite television receivers	In	Out
09 IT	0912	金融及贸易结算电子设备（电磁兼容） Finance and Trade settlement equipment	In	Out
10 Lum.	1001	儿童用可移动式灯具 Portable luminaires for Children	Out	In
15 Med.	1 type	橡胶避孕套 Latex products	In	Out (Removal by CNCA Announcement 8, May,2013)
17 Med.	1701-1712	医疗设备 Medical devices	In	

News Update – Standard Update

	Old Standard	New Standard	Product Involved	Published Date	Implementation Date	Upgrading before	Deadline before
1	GB8898-200 (IEC60065)	GB4943-2011 (IEC60065:2005, MOD)	08: AV	Nov.30,2011	Nov.1,2012	Nov.1,2013 (Suspend)	Feb.1,2014 (Withdraw)
2	GB4943-2007 (IEC60950)	GB4943-2011 (IEC60950-1:2005, MOD)	09: ITE 16: TTE	Dec.30,2011 (Jan. 2013))	Dec.1,2012	Dec.1,2013 (Suspend)	Mar.1,2014 (Withdraw)
3	GB4706.32-2004 (IEC60335-2-40:1995 IDT)	GB4706.32-2012 (IEC60335-2-40:2005 IDT) [GB4706.1-2005]	0703: HH (Air conditioner	Jun.29,2012 (Mar.29, 2013)	May 1, 2013	May 1, 2014 (Suspend)	Aug.1,2014 (Withdraw)
4	GB17625.1-2003	GB17625.1-2012 (IEC61000-3-2:2009 IDT)	05: Tools 07: HH 08: AV 09: ITE 10: Lum. 1602: if	Dec.31, 2012 (Apr. 2013)	Jul.1, 2013	Jul. 1, 2014 (Suspend)	Oct.1,2014 (Withdraw)
5	GB13837-2003	GB13837-2003 (IEC/CISPR 13:2009 MOD)	08	Dec.31, 2012 (Apr. 2013)	Jul.1, 2013	Jul. 1, 2014 (Suspend)	Oct.1,2014 (Withdraw)
6	GB2099.2-1997	GB2099.2-2012 (IEC 60884-2-2:2006 MOD) [GB2099.1-2008]	0201: Plugs and socket- outlets	Dec.31, 2012 (Sep.5,2013)	Dec.1, 2013	Dec.1, 2014 (Suspend)	Feb.28,2014 (Withdraw)

One-Stop Full Services

**Your reliable partner in
China approvals**

**Your powerful and
professional assistant for
market access to China**



**Biggest partner of CQC in
follow up factory inspection
in Europe, North America
and Asia**

**One-stop full service
provider for you**



TÜV Rheinland - Your Reliable Partner

Contact Info.

**Thank you for your
participating!!!**

TÜV Rheinland Taiwan Ltd.
Market Access Services
Ms. Jane Peng
jpe@twn.tuv.com

TÜV Rheinland of North America, Inc.
Market Access Services (west coast)
Ms. Lina Kwee
Tel: +1 (925) 249-9123
Fax: +1 (925) 249-9124
lkwee@us.tuv.com

TÜV Rheinland of North America, Inc.
Market Access Services (east coast)
Ms. Suzanna Nagy
Tel: +1 (978) 266 9500 x 261
Fax: +1 (978) 266-9992
snagy@us.tuv.com

Visit us @ www.tuv.com