

AlphaXpress DMS Sign Maintenance Manual

P1501-2 Miami Retrofit

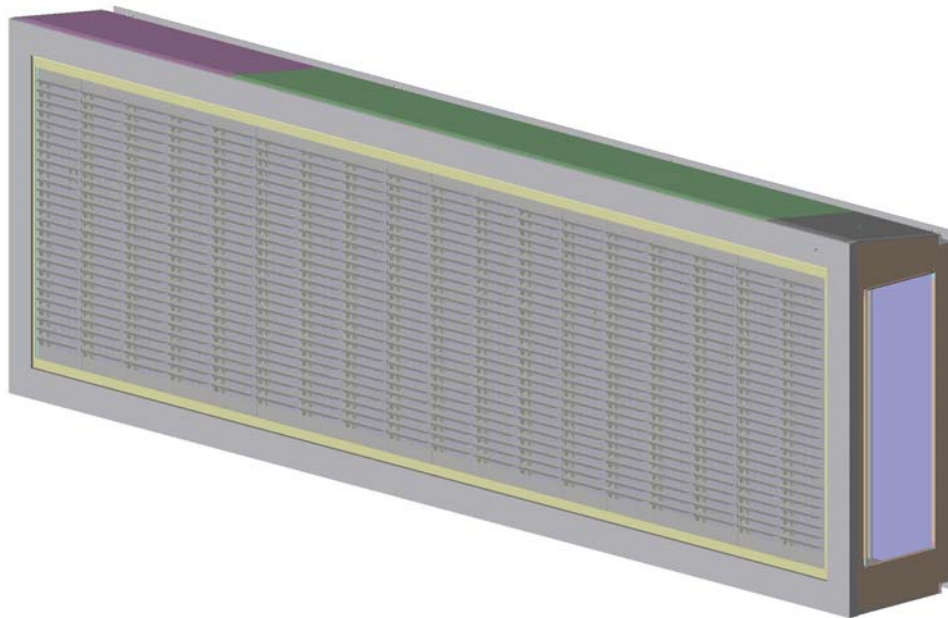

Manual part number: 1501610101A

Revision date: August 23, 2006

© Copyright 2006 Adaptive Micro Systems LLC. All rights reserved.

Adaptive Micro Systems

7840 North 86th Street

Milwaukee, WI 53224 USA

414-357-2020

414-357-2029 (fax)

<http://www.adaptivedisplays.com>

Trademarked names appear throughout this document. Rather than list the names and entities that own the trademarks or insert a trademark symbol with each mention of the trademarked name, the publisher states that it is using names for editorial purposes and to the benefit of the trademark owner with no intention of improperly using the trademark.

The following are trademarks of Adaptive Micro Systems: Adaptive, Alpha, AlphaLert, AlphaNET, AlphaNet plus, AlphaEclipse, AlphaEclipse RoadStar, AlphaEclipse StreetSmart, AlphaPremiere, AlphaTicker, AlphaXpress, AlphaVision, AlphaVision InfoTracker, Automode, BetaBrite, BetaBrite Director, BetaBrite Messaging Software, Big Dot, Director, EZ KEY II, EZ95, PagerNET, PPD, PrintPak, Serial Clock, Smart Alec, Solar, TimeNet.

The distinctive trade dress of this product is a trademark claimed by Adaptive Micro Systems LLC.

Due to continuing product innovation, specifications in this manual are subject to change without notice.

Contents

1.0	Introduction.....	5
1.1	Purpose	5
1.2	Related documentation	5
1.3	Safety information	5
1.3.1	Equipment symbols	5
1.3.2	Warnings and cautions	5
1.3.3	Battery backup	6
2.0	Equipment description	7
2.1	General description	7
2.2	Outside views.....	8
2.3	Inside view.....	9
2.3.1	General inside view	9
2.3.2	Controllers	10
2.3.3	Sign power panels	16
2.3.4	LED driver board	17
3.0	Maintenance	19
3.1	Physical Inspection	19
3.1.1	Exterior inspection	19
3.1.2	Interior inspection	19
4.0	Troubleshooting	21
4.1	Introduction	21
4.2	Tools required for Troubleshooting and repair.....	21
4.3	Common problems	22
4.3.1	Inoperative AC power	22
4.3.2	Inoperative DC power.....	22
4.3.3	Nonfunctional brightness control nonfunctional sign.....	23
4.3.4	Nonfunctional single LED(s) functional sign	24
4.3.5	Nonfunctional single pixel(s) functional sign	24
4.3.6	Nonfunctional pixels on entire display board(s) functional sign.....	24

5.0 Part replacement 25

- 5.1 List of field-replaceable parts 25
- 5.2 Controlling electrostatic discharge (ESD) 25
- 5.3 Sign controller board replacement 26
- 5.4 Power supply replacement 29
 - 5.4.1 Sign power supplies 29
 - 5.4.2 Ground controller power supply 31
- 5.5 LED driver board replacement 32
- 5.6 Light sensor replacement 35

1.0 Introduction

1.1 Purpose

This manual is intended as a guide for maintenance and repairs considered field serviceable.

This field service manual supplies technical information for service and technical personnel so that they can maintain the equipment at the assembly but not the component level.

1.2 Related documentation

Technical documentation can be found at Adaptive's web site (<http://www.adaptivedisplays.com>):

Table 1: Related documentation

Part #	Title	Description
TechMemo #05-0005	Preventing Electrostatic Discharge (ESD) Damage	Describes the precautions to take to protect electronic components from ESD damage.
15015003DR	Reference Wiring Diagram	Electrical wiring diagram.

1.3 Safety information

1.3.1 Equipment symbols



Chassis ground

1.3.2 Warnings and cautions

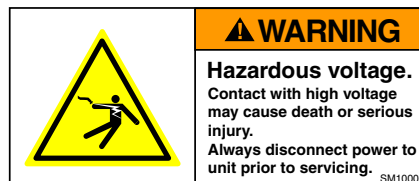

Other warnings and cautions are posted in appropriate location throughout this manual.

1.3.3 Battery backup

In the event of a power loss, two lithium and one, sealed lead-acid batteries provide power to the sign's two controller boards and ground controller.

NOTE: The backup batteries only provide enough power to operate the sign's controllers, not the sign's LED displays.

1.3.3.1 3V lithium backup batteries

One 3V lithium battery is located on each of the sign's two controller boards

3V lithium battery
(Panasonic CR2032 or
equivalent).

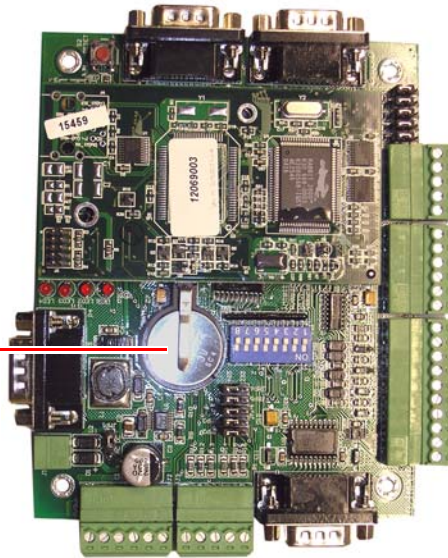

⚠ WARNING	
	<p>Danger of explosion if battery is incorrectly replaced. Replace only with the same or equivalent type recommended by the manufacturer. Dispose of used batteries according to the manufacturer's instructions.</p> <p style="text-align: right; font-size: small;">SM1019A-EA</p>

2.0 Equipment description

2.1 General description

- Serviceability: Walk in.
- Display size: 27 LED pixel rows x 108 LED pixel columns (see Figure 1).
- Character height: 18 inches, nominal (see Figure 1).
- Character width: 9 inches, nominal (see Figure 1).

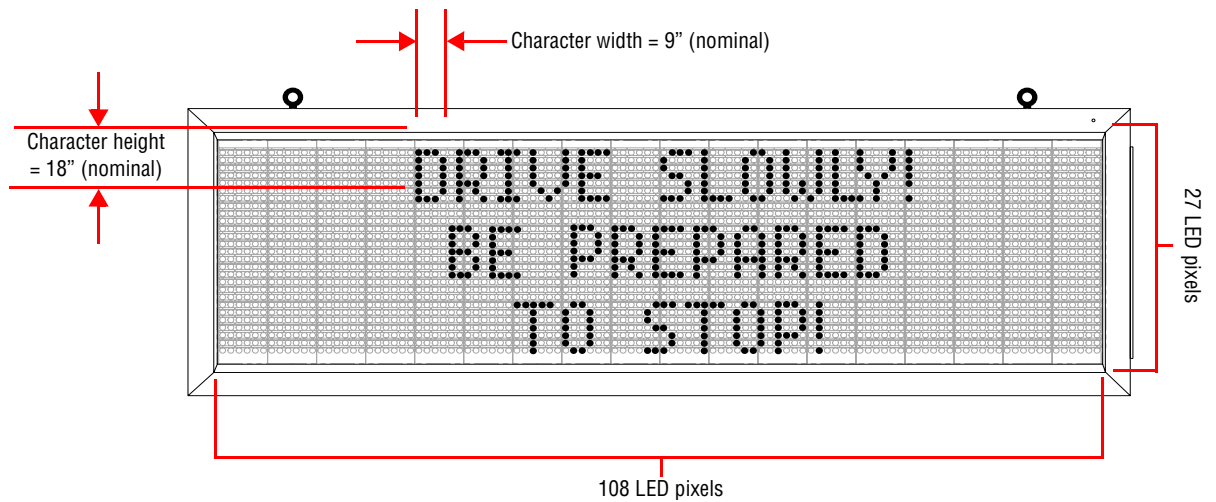

Figure 1: Display size

- Pitch (distance between each LED pixel): 2.6 inches:

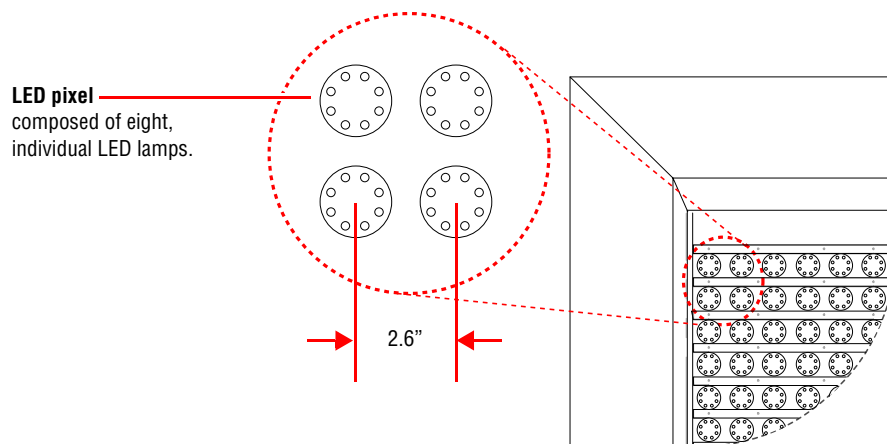
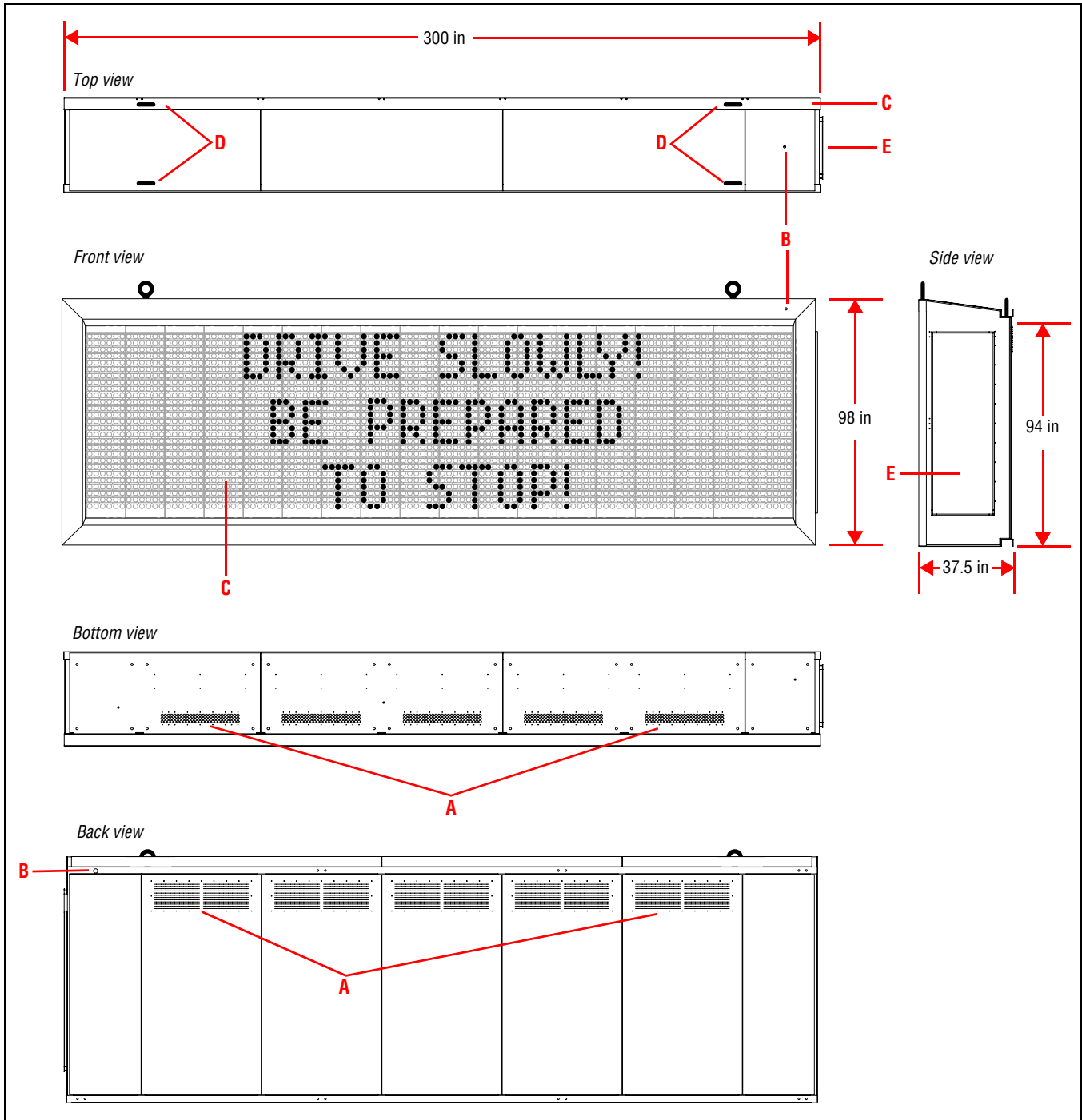

Figure 2: LED pitch

2.2 Outside views



Item	Name	Description
A	Air vents	Fans located on the sign floor push air through these vents.
B	Light sensor	Used for dimming the sign LEDs. There are 3 light sensors used in the sign.
C	LEDs	Used to display messages.
D	Lifting eyebolts	Used to lift the sign into place for mounting. All four eyebolts must be used to lift this sign (see "2.2 Mechanical installation" on page 8).
E	Access door	Allows walk-in entry to the inside of the sign.

2.3 Inside view

2.3.1 General inside view

Inside front view

Protective panels cover the controller plate, load center, and all the power panels.

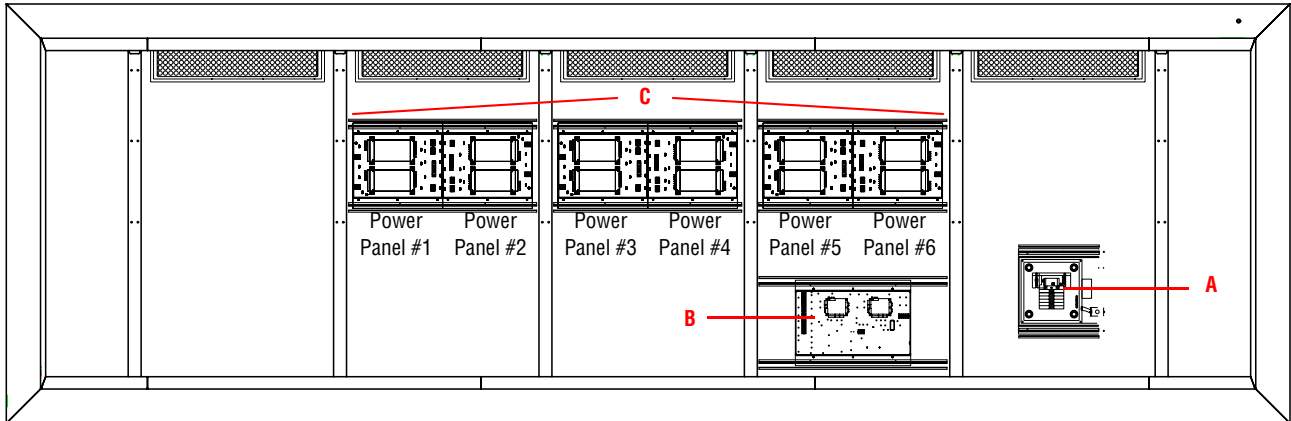

Item	Name	Description
A	Load center	AC for sign.
B	Controller plate	Contains sign controller #1 and #2.
C	Power panels	Provides DC power to display and controller.

2.3.2 Controllers

2.3.2.1 Sign controllers #1 and #2

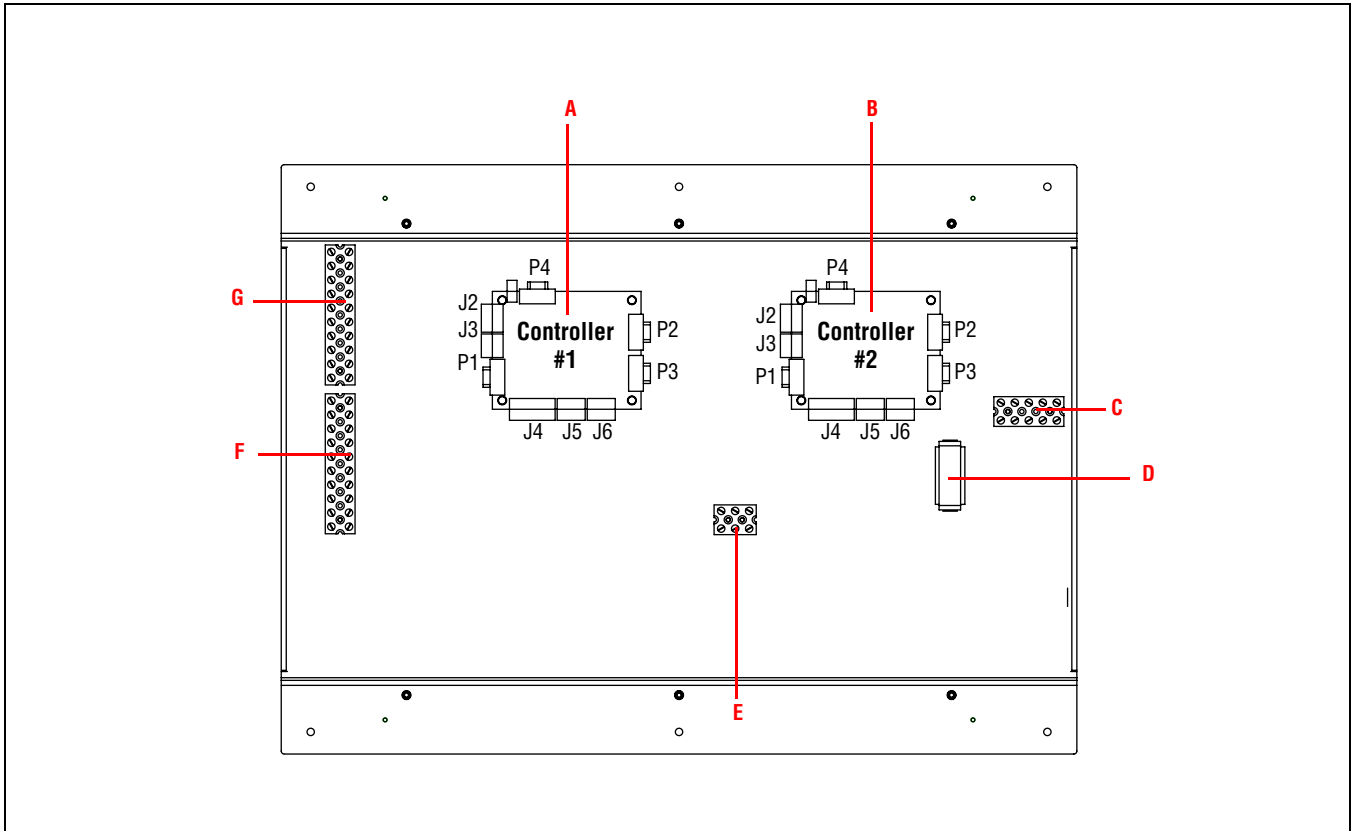

Item	Name	Part #	Description
A	Controller #1	12069003	<p>These two boards (see Table 2 on page 12) control sign operation in conjunction with the ground controller which is connected to an NTCIP network:</p>
B	Controller #2	12069003	

C	Terminal block #1	43201044	RS422 transmit/receive connection between Controller #1 and the ground controller.
D	Surge protector	30350019	<p>Protects the RS422 transmit/receive connection from a peak surge current of 10kA. There are two surge protectors: one in the sign and the other in the sign controller cabinet:</p> <div style="text-align: center;"> <p>FIELD SIDE</p> <p>Unprotected Pair 2 { 9, 7 } Unprotected Pair 1 { 5, 3 } 1</p> <p>ELECTRONICS SIDE</p> <p>10 Protected Pair 2 { 8, 6 } Protected Pair 1 { 4, 2 }</p> <p>Pins 1 and 10 are the same point electrically.</p> </div>
E	Terminal block #2	43201043	Distributes power to the relays and humidity sensor.
F	Terminal block #4	43201054	Provide wiring for status signals such as power fail signals for power supplies, fan monitoring, door switch, and DC power for the controller assembly.
G	Terminal block #5	43201054	

Table 2: Sign controllers

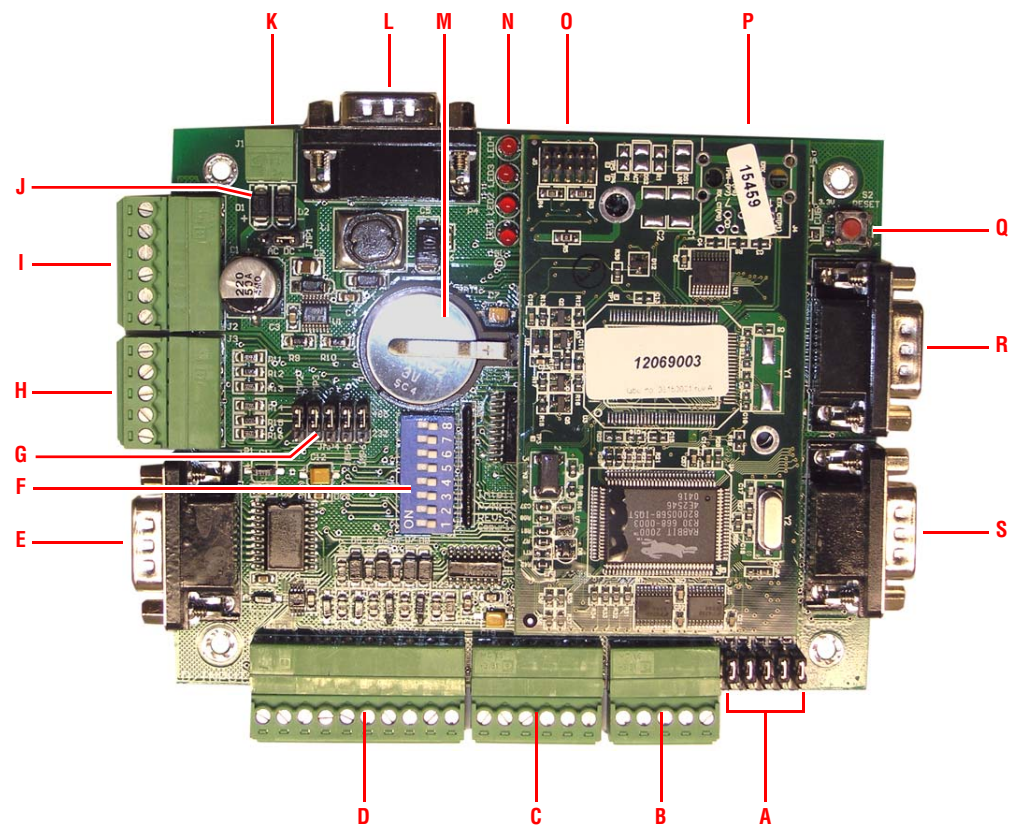

Item	PCB label	Name	Description
A	JP7 to JP11		
B	J6	RS485 Port 1	<ul style="list-style-type: none"> Controller #1 — connects to LED displays. Controller #2 — connects to light sensors.
C	J5 A/INPUT	Analog inputs	<ul style="list-style-type: none"> Controller #1 — connects to humidity sensor. Controller #2 — not used.
D	J4 D/INPUT	Digital inputs	<ul style="list-style-type: none"> Controller #1 — connects to door switch, power supply fail signals, and Relay 3 (fans). Controller #2 — connects to power supply fail signals.
E	P1	RS232 port	Not used.
F	S1	DIP switches	<ul style="list-style-type: none"> Controller #1 (DIP switch #1 on for Controller #1). Controller #2 (DIP switch #2 on for Controller #2). Both controllers.
G	JMP2 to JMP6		Set per wiring diagram 15015003DR.
H	J3	RS422 port	Used to interface both controllers to the ground controller.
I	J2	Digital outputs	Set per wiring diagram 15015003DR.
J	JMP1		Set differently for Controller #1 and Controller #2.
K	J1	Power connector	Set to DC.
L	P4	RS232 port	Not used.
M	BAT1	Battery backup	3V lithium battery (Panasonic CR2032 or equivalent).

Table 2: Sign controllers

N	LED1 to LED4	Diagnostic LEDs	<ul style="list-style-type: none"> • LED1: <ul style="list-style-type: none"> <input type="checkbox"/> Controller #1 = Heartbeat. <input type="checkbox"/> Controller #2 = Heartbeat. <input type="checkbox"/> Controller #3 (Ground Controller) = Heartbeat. • LED2: <ul style="list-style-type: none"> <input type="checkbox"/> Controller #1 = Communications from Controller #3 J3. <input type="checkbox"/> Controller #2 = Communications from Controller #3 J3. <input type="checkbox"/> Controller #3 (Ground Controller) = Communications from Central/Local port P1 and P2 and Ethernet. • LED3: <ul style="list-style-type: none"> <input type="checkbox"/> Controller #1 = Flashes when responses come from J6 LED display board. <input type="checkbox"/> Controller #2 = Flashes when responses come from J6 light sensor. <input type="checkbox"/> Controller #3 (Ground Controller) = Flashes when responses come from sign controller on J6. • LED4: <ul style="list-style-type: none"> <input type="checkbox"/> Controller #1 = Flashes when transmitting out of J6 LED display board. <input type="checkbox"/> Controller #2 = Flashes when transmitting out of J6 light sensor. <input type="checkbox"/> Controller #3 (Ground Controller) = Flashes when transmitting goes to sign controllers on J6.
O	J5	Programming port	
P	J4	Ethernet port	
Q	S2 RESET	Controller reset switch	Used to do a soft reset on the controller.
R	P3		Not used.
S	P2		Not used.

2.3.2.2 Ground controller (Controller #3) panel

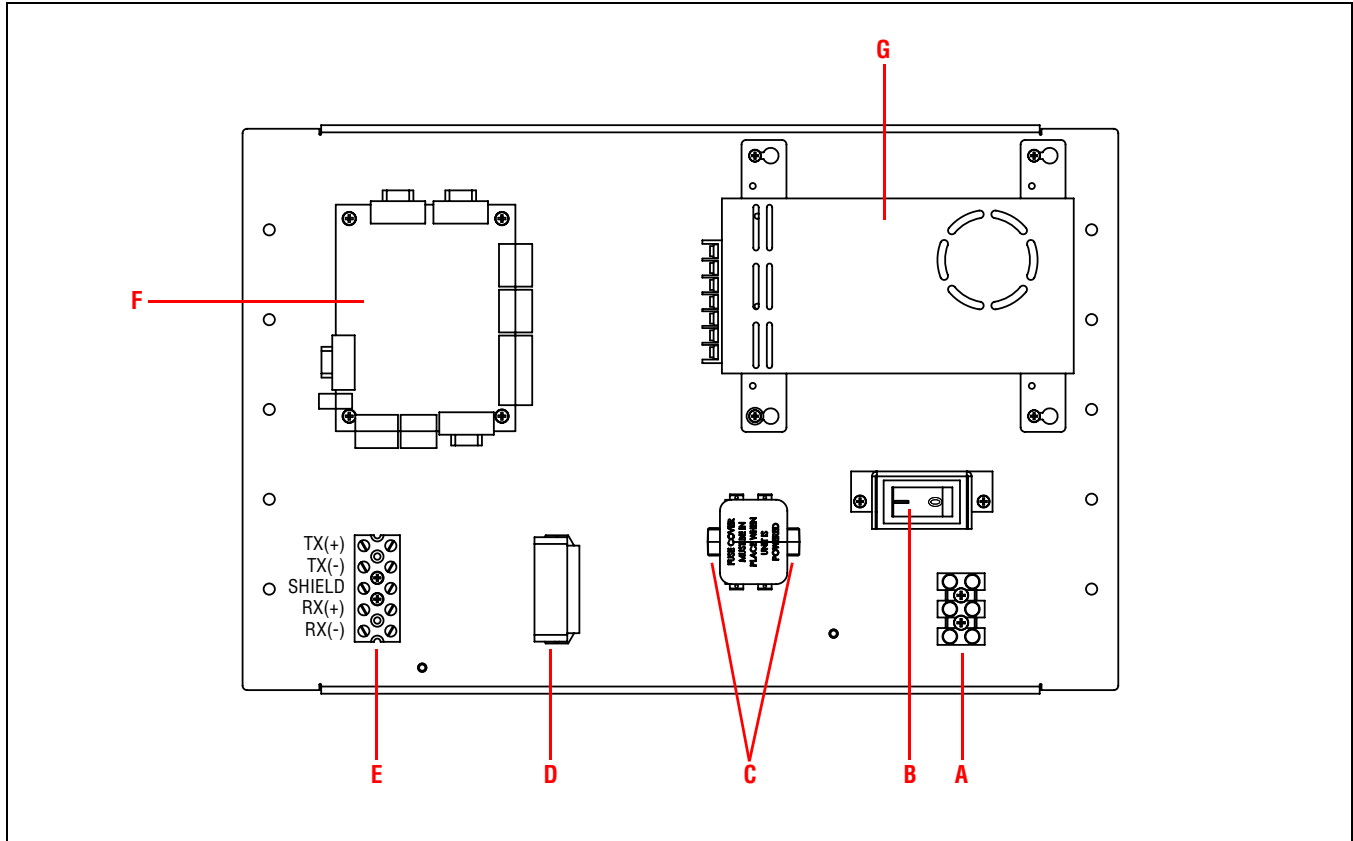

Item	Name	Part #	Description
A	Terminal block	43201036	AC power terminal. 3 position x 2, 15mm, 50A.
B	Switch	41000233	AC power switch. DPDT, 20A.
C	Fuses	48020003	Two, 1.5A, 250V, 3AG, SLO-BLO.
D	Surge protector	30350019	<p>Protects the RS422 transmit/receive connection from a peak surge current of 10kA. There are two surge protectors: one in the sign and the other in the sign controller cabinet:</p> <div style="text-align: center;"> </div> <div style="border: 1px solid black; padding: 5px; width: fit-content; margin-left: auto; margin-right: auto;"> Pins 1 and 10 are the same point electrically. </div>
E	Terminal block	43201044	RS422 connection to sign controller. 5 position x 2, 8-24AWG, 600V, 50A.

<p>F</p>	<p>Ground controller</p>	<p>15029101</p>	<p>This board is connected to an NTCIP network and works in conjunction with the two sign controller boards to control sign operation:</p>
<p>G</p>	<p>Power supply</p>	<p>40656301</p>	<p>Meanwell SP-200-12 switching power supply, 12VDC output:</p>

2.3.3 Sign power panels

There are 6 power panels in the sign (see “2.3.1 General inside view” on page 9). Each panel contains two, Meanwell PSP-500-12 12VDC output power supplies.

NOTE: Both power supplies may not turn on at the same time if there is not enough display load.

Power supply DC output (front view)

Power supply AC input (back view)

Item	Power supply label	Name	Description
A	V+	12VDC +	DC output
B	V-	12VDC -	
C		DC output voltage adjust	Adjustment range = 10 to 13.2VDC. Output should be set to 12VDC.
D		Input power indicator	Green = AC voltage supplied to power supply.
E		Signal connector	Used for power sharing function, remote sense, and power good signal.
F		AC in ground	AC input (90-264VAC, 47-63Hz)
G	AC/N	AC in neutral	
H	AC/L	AC in neutral	

2.3.4 LED driver board

There are 54 LED driver boards in a sign. Each board is 6 x 9 pixels, and each pixel is composed of 8 LED lamps.

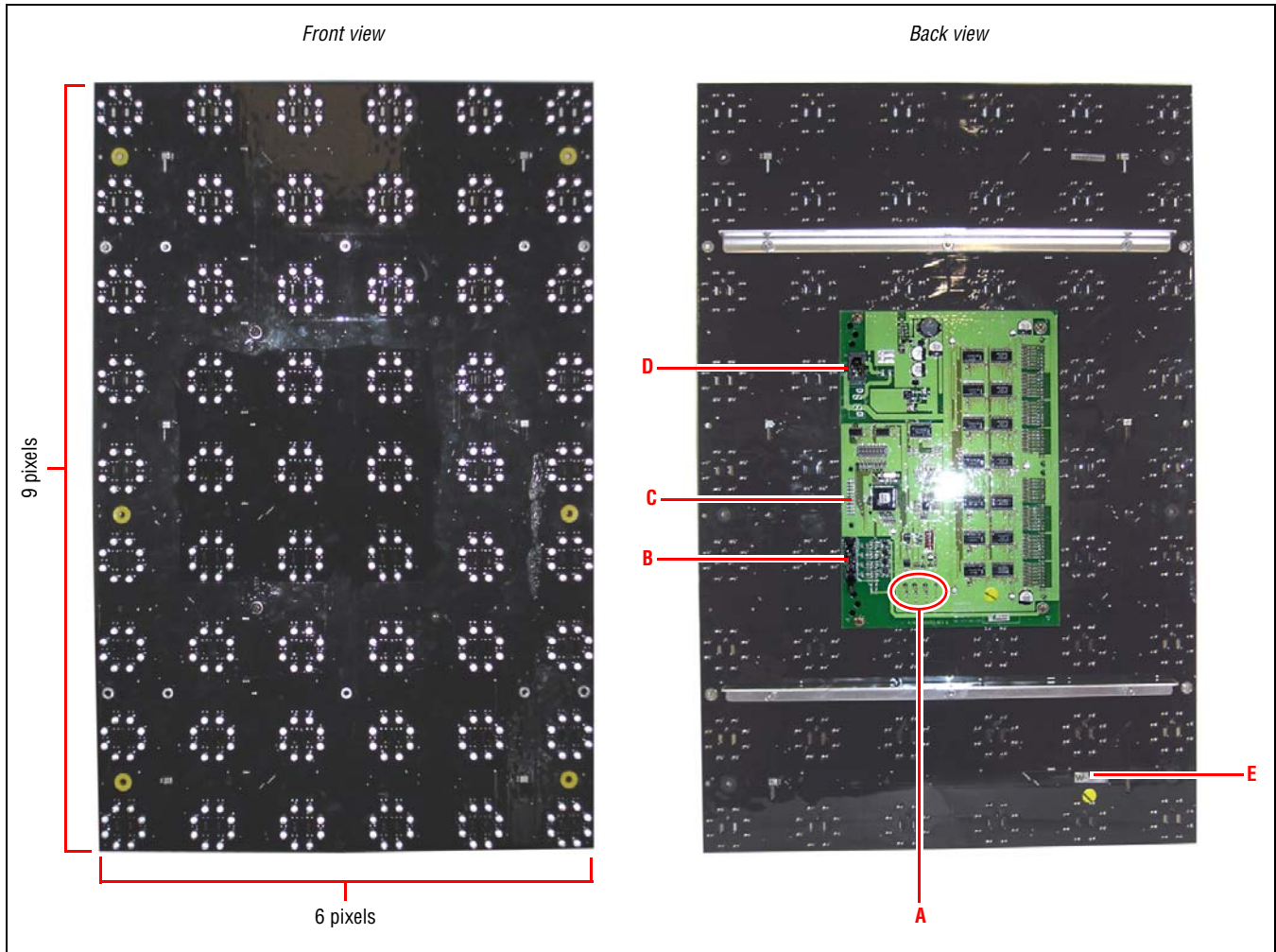

Item	PCB label	Name	Description
A	LD1	POWER	On = 12V supplied to LED driver board logic.
	LD2	FAULT	On = one or more bad LED lamps on the LED driver board (if in normal operating mode).
	LD3	COMM	<ul style="list-style-type: none"> On = There is NO communication from sign controller. Off = There is communication from the sign controller.
	LD4	RUN	Flashing = LED driver board processor operating.
B	P3	Data	Connects to Controller #1 via a ribbon cable.
C	P2	Address connector	Used to address LED driver board.
D	P1	Power	Supplies power to the LED driver board.
E		BIN label	Information on the intensity and wavelength of the LED lamps, for example: 

THIS PAGE INTENTIONALLY BLANK

3.0 Maintenance

3.1 Physical Inspection

3.1.1 Exterior inspection

- Check for any physical damage to the exterior of the sign.
- Check for any physical damage to the interior of the sign.
- Check for loose nuts, bolts, hinges, doors, etc. on the sign.
- Check the electronics for foreign debris and general cleanliness.
- Check the interior of the sign for foreign debris and general cleanliness.
- Check the exterior of the sign for general cleanliness.
- Check the LEDs of the sign for general cleanliness and visibility.

3.1.2 Interior inspection

- Check for any obvious physical damage to the interior.
- Check for loose nuts, bolts, hinges, doors, and so on.
- Check the electronics for foreign debris and general cleanliness.
- Make sure the sign's drain holes are not plugged.

THIS PAGE INTENTIONALLY BLANK

4.0 Troubleshooting

This chapter contains the LED Variable Message Sign (VMS) Trouble Shooting and a general explanation of how each problem can be isolated through a step by step direction.

4.1 Introduction

Due to the complexity of the electronic equipment, it is impossible to describe every possible malfunction that could occur. The intent of this section is to follow a path from the beginning to the end of each system so that a general understanding of the operating system is established. When the sign is not functioning properly, these procedures should help you access the electronics and isolate the defective component(s) in the sign. The defective components may then be removed and replaced with a known good component. The topics discussed and most common problems that you might experience are listed below.

If none of the procedures suggested in this chapter produce a satisfactory solution, you may contact the Adaptive Micro Systems Service Department at 414-357-2020 during normal business hours.

4.2 Tools required for Troubleshooting and repair

In all cases of troubleshooting and repair some tools are required to perform these tasks. The following is a list of common test equipment and tools required to test, remove and replace a defective PCB and/or piece of hardware:

- DMM (Digital Multi Meter)
- 1/8" slotted screwdriver
- 3/16" slotted screwdriver
- #2 Phillips screwdriver
- #3 Phillips screwdriver
- 3/16" nutdriver
- 1/4" nutdriver
- 3/8" nutdriver
- 7/16" nutdriver
- 6" or 8" slip joint pliers
- Needle nose pliers
- Wire strippers (multi gauge)

Access to the electronics and operating system is required to perform the procedures listed herein. Make sure that you have all codes, keys, combinations, and special entry tools.

4.3 Common problems

4.3.1 Inoperative AC power

Most common problems to the AC side are as following:

- Cable connection not properly secured or came off
- Bad power supply
- Circuit Breaker tripped
- Corroded terminals
- Blown Lighting Arrestor (TVS)

When following these step-by-step procedures, continue going down the numbered list until the problem has been identified and isolated. While troubleshooting the system, make sure that all cables are properly connected and making positive contact (in some cases loose cables are the cause of the problem).

- Verify AC power to the power panel providing power to the sign controllers.
- Verify AC power to the power supply providing power to the ground controller.
- In the load center, verify that AC power is applied to the power supply boxes across breakers.
- In the power supply panels, verify that AC power is applied to all the power supplies, across input terminals. Reference wiring diagrams (see “2.3.3 Sign power panels” on page 16) for power supply panel view and measure across TB1 and TB2 to verify AC voltage is present.

Observe safety practices because this is HIGH VOLTAGE that you are measuring and could result in serious injury.

- If satisfactory results from each AC power test points have been achieved, continue to the next section. If during the testing a problem is found, repair or replace the component.

4.3.2 Inoperative DC power

The most common problems to the DC side are the following:

- Cable connection not properly secured.
- Cable connection came off.
- Bad power supply.
- Defective printed circuit board.
- Corroded terminals.

When following these step-by-step procedures, continue going down the numbered list until the problem has been identified and isolated. While troubleshooting the system, make sure that all cables are properly connected and making positive contact (in some cases loose cables are the cause of the problem).

- The DC power is checked after the AC power side has been verified.
- In the power supply panels, verify that the 12VDC power is present at the +V and -V, terminals TB3, and TB4. Orange is V+ and Violet is V-.

- In the LED driver board, verify that DC power is present on the LED driver board. Check LED indicator LD1 (labeled *POWER*). If it is lit, then power is supplied to the board. Also check the power connector for 12VDC. Orange is V+ and Violet is V-.
- Light sensor/temperature sensor board LS0-2. Check +12VDC (pin 11) and GND (pin 9) on the boards.
- In most cases when the sign is inoperative, the problem is with a piece of hardware that causes the sign to blank or prevents data from getting to the sign. If a problem is found during the testing, repair or replace the component.

4.3.3 Nonfunctional brightness control nonfunctional sign

- If one or more photocell sensors are nonfunctional, the sign will still operate. The sign will dim according to ambient light levels unless all three are non-functional.
- Check all connections to and from the photocell sensor board and make sure the cables are connections are ok. Check for 12VDC power at the photocell.
- Check software to make sure the sign is not in a “blank” mode.
- Check the address switch on the photocell and the configuration JUMPERS (J6-JMP7-11) on the controller board.
- Verify light sensors are addressed properly.
- Verify COM LED indicator is flashing on each light sensor.
- To verify each light sensor is working, first make sure that sign is in photocell mode first using Intelligent Control. Then check each sensor separately:
 - ❑ Front light sensor verification:
 - Cover the back and top light sensors.
 - Using Intelligent Control, check the Status screen to see if a photocell reading is present. If above 2 out of 15, cover the front photocell. The value should decrease to 1. If all is as described, go to top light sensor verification.
 - If the value is less than 2 out of 15, shine a floodlight on photocell to saturate the light sensor. The value should change within 30 seconds. If status of the light value increases, continue to top light sensor verification. If status does not increase, then replace the light sensor board.
 - ❑ Top light sensor verification:
 - Cover the front and back light sensors.
 - Using Intelligent Control, check the Status screen to see if a photocell reading is present. If above 2 out of 15, cover the top photocell. The value should decrease to 1. If all is as described, go to back light sensor verification.
 - If the value is below 2 out of 15, shine a floodlight on photocell to saturate the light sensor. The value should change within 30 seconds. If status of the light value increases, continue to back light sensor verification. If status does not increase, then replace the light sensor board.
 - ❑ Back light sensor verification:
 - Cover the top and back light sensors.

- Using Intelligent Control, check the Status screen to see if a photocell reading is present. If above 2 out of 15, cover the back photocell. The value should decrease to 1. If all is as described, all light sensors are working properly.
- If the value is below 2 out of 15, shine a floodlight on photocell to saturate the light sensor. The value should change within 30 seconds. If status of the light value increases, then all light sensors are working. If value does not increase, then replace the pcb assembly.
- Remove and replace the board.

4.3.4 Nonfunctional single LED(s) functional sign

- Remove and replace the LED driver board containing the bad LED(s).

4.3.5 Nonfunctional single pixel(s) functional sign

- In Intelligent Control, run the Pixel Test to locate where the bad pixel is located.
- Remove and replace the LED driver board containing the bad pixel(s).

4.3.6 Nonfunctional pixels on entire display board(s) functional sign

- In Intelligent Control, run the Pixel Test to locate where the bad pixel(s) is/are located.
- Verify that the DC power supplies are not defective and tests for presence of voltage.
- If the test indicates a bad set of power supplies, remove and replace the power supply supplying power to the display boards. If the voltage at the LED driver board is less than 10.5VDC, this may show pixel failures for the pixel diagnostics.
- If power supplies are OK, remove and replace the LED driver board containing the bad pixel(s).

5.0 Part replacement

5.1 List of field-replaceable parts

Table 3: Field-replaceable parts

Part name	Page
Sign controllers	page 26
Power supplies	page 29
LED driver board	page 32
Light sensor	page 35

5.2 Controlling electrostatic discharge (ESD)



This equipment contains components that may be damaged by “static electricity”, or electrostatic discharge. To prevent this from happening, be sure to follow the guidelines in Adaptive TechMemo 00-0005, “*Guidelines for Controlling Electrostatic Discharge Damage*”, available at Adaptive’s web site at <http://www.adaptivedisplays.com>.

5.3 Sign controller board replacement

1. Turn all sign breakers to the OFF position, except the breaker for the sign lights. See “NOTE: Both power supplies may not turn on at the same time if there is not enough display load.” on page 16.



2. Loosen, but do not remove, the screws (circled below) on the protective cover over the controller plate. Then remove the cover:

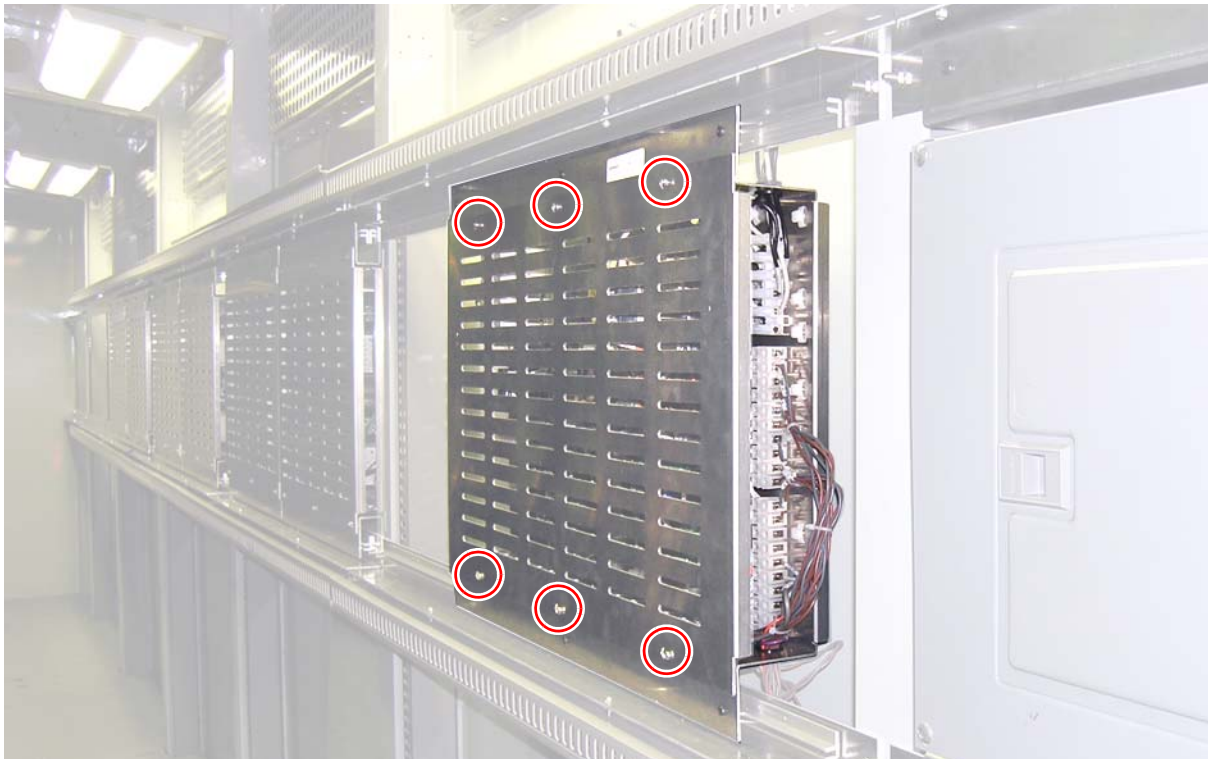

View is representative of field installation.

3. Locate the controller board (either Controller #1 or #2) to be replaced. See Table 3 on page 27.

4. Set the DIP switches on the *replacement* controller board so they match the DIP switch settings on the board to be replaced:

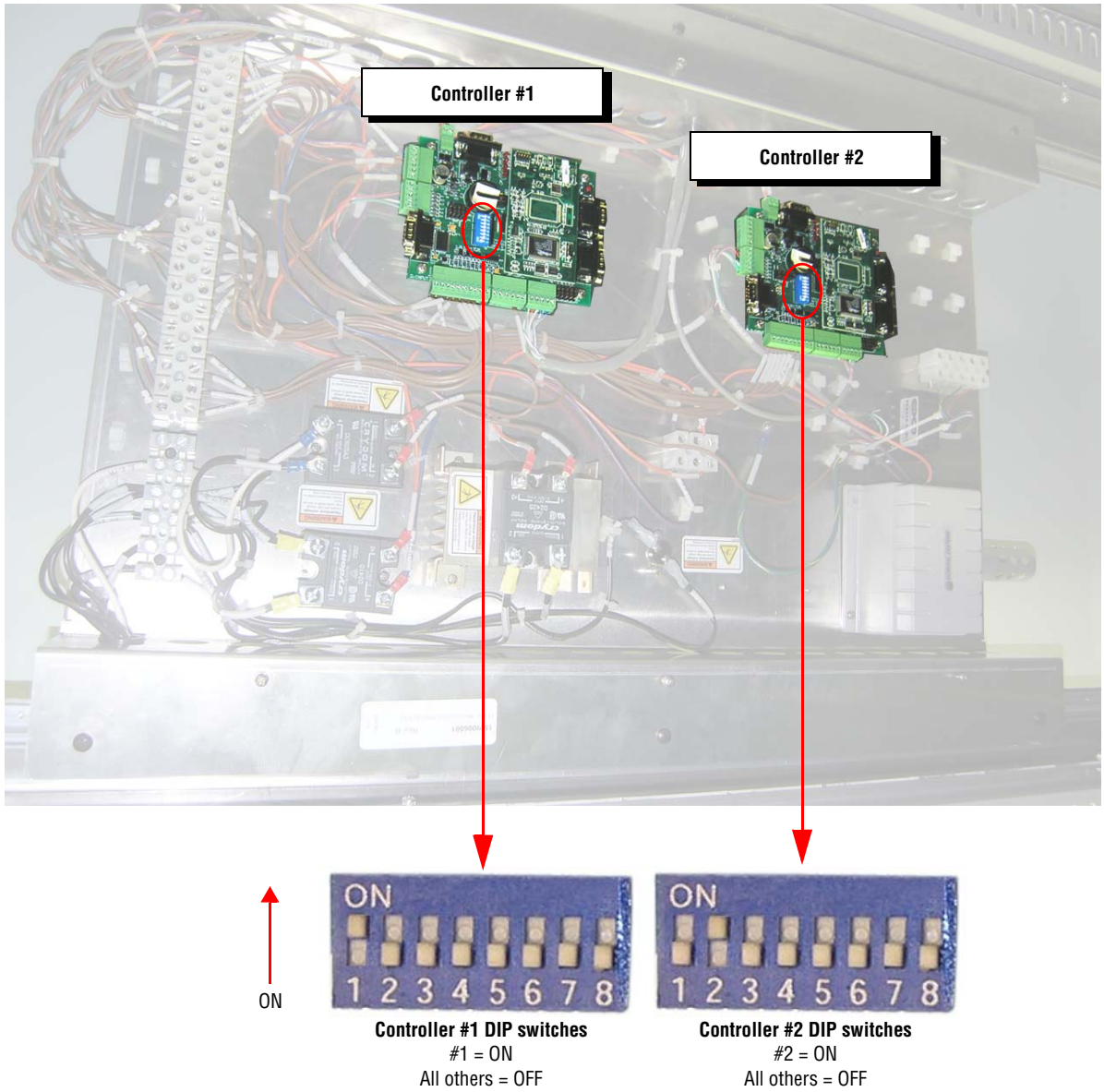
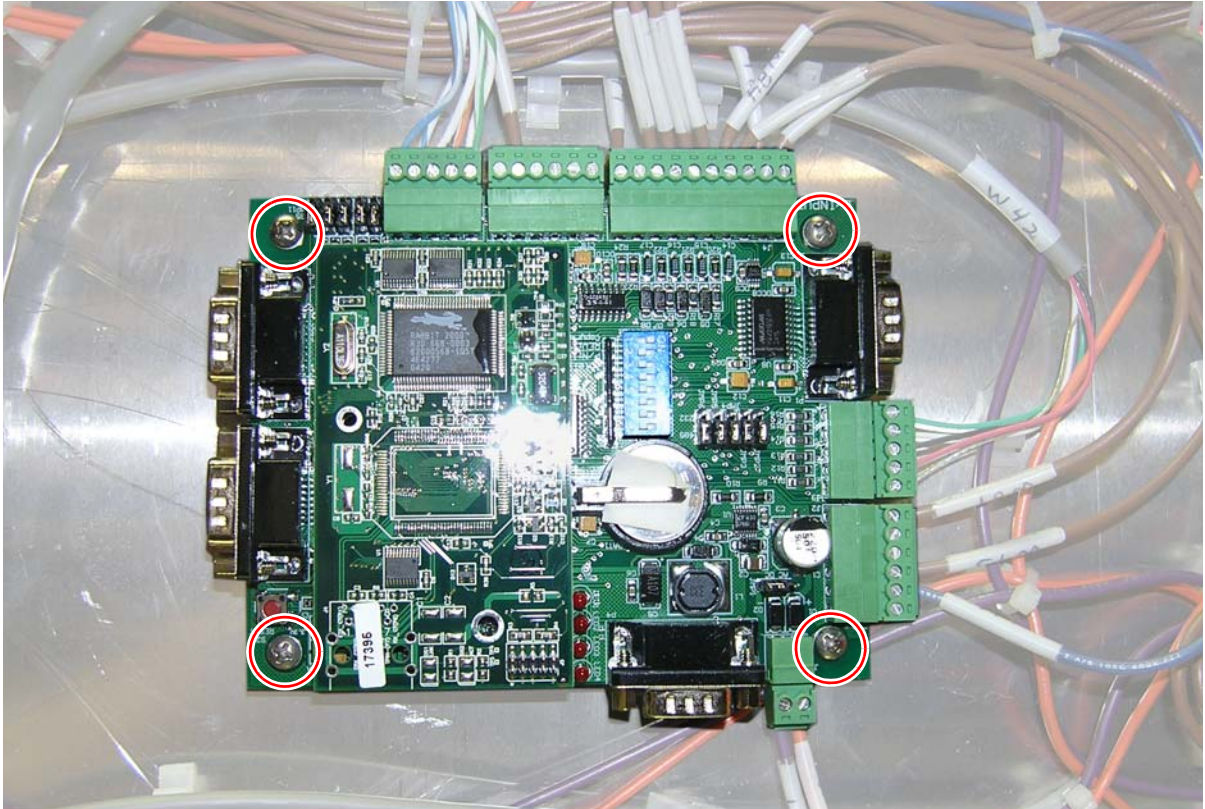

Figure 3: Sign controller boards.

View is representative of field installation.

5. Disconnect all cables from the controller board to be replaced.

6. Remove the four screws (circled below) that hold the controller board to the sign:



7. Fasten the new controller board to the sign. Then reconnect all the cables to the new board.
8. Reattach the protective cover over the controller plate.
9. Close the sign and apply power to the sign.

5.4 Power supply replacement

Two types of power supplies are used:

- Meanwell PSP-500-12 (see “5.4.1 Sign power supplies” on page 29) — This 12VDC output power supply is used *inside* the sign.
- Meanwell SP-200-12 (“5.4.2 Ground controller power supply” on page 31) — This is the 12VDC output power supply used *on the ground controller plate*.

5.4.1 Sign power supplies

1. Turn all sign breakers to the OFF position, except the breaker for the sign lights.

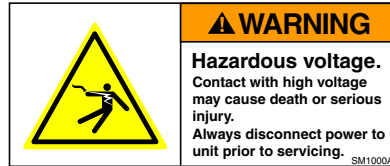

2. Loosen, but do not remove, the screws (circled below) on the protective cover over the power panel. Then remove the cover:



View is representative of field installation.

3. Remove all wires from the power supply to be replaced:

DC connections:

- ❑ V+ (orange-colored wire)
- ❑ V- (violet-colored wire)
- ❑ Signal harness

AC connections:

- ❑ Hot (black wire)
- ❑ Neutral (white wire)
- ❑ Ground (green wire)

4. Remove the four screws (circled below) that hold the power supply to the power panel:

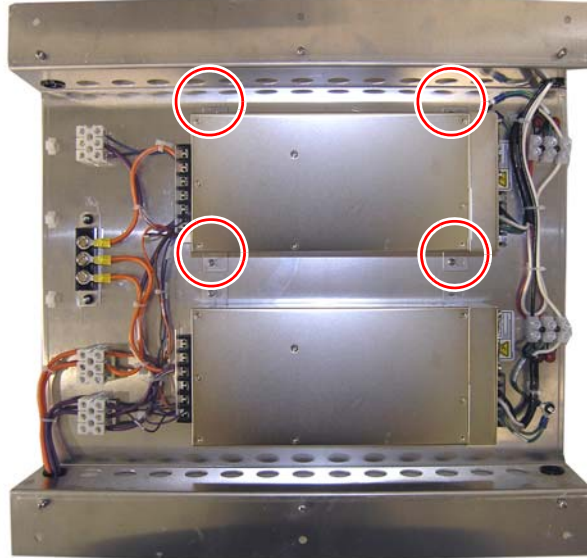

5. Fasten the new power supply to the power panel. Then reconnect all the wires to the new power supply.
6. Reattach the protective cover to the power panel.
7. Close the sign and then apply power to the sign.

5.4.2 Ground controller power supply

1. Remove power from the ground control panel.



2. Remove all wires from the power supply:



If the replacement power supply does not have a ground spade connecting -V and ⏏ . Then transfer this ground spade to the replacement power supply.

3. Loosen, but do not remove, the 4 screws that hold the power supply to the ground controller plate. Then remove the power supply:

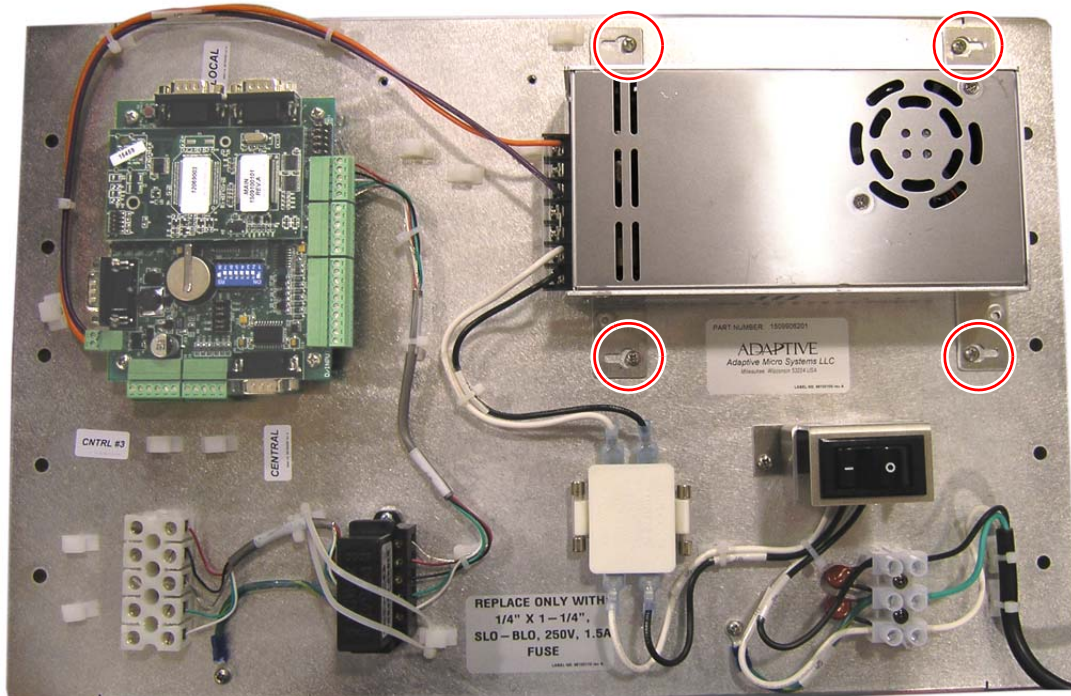

4. Fasten the new power supply to the sign. Then reconnect all the wires to the new power supply.
5. Close the sign and then apply power to the sign.

5.5 LED driver board replacement

NOTE: To match the color and intensity of the sign's LEDs, you may need to determine the BIN letter of the LED driver board to be replaced (see "2.3.4 LED driver board" on page 17).

1. Turn all sign breakers to the OFF position, except the breaker for the sign lights.



2. Locate the LED driver board to be replaced.
3. Remove the protective panel that covers the back of this LED driver board:



Use these hand holds to lift the panel up and then off.

Place the panel out of the way.

4. In the following order, remove these cables from the back of the LED driver board:

- Power cable (P1)
- Address wire harness (P2)
- Communications cable (P3)

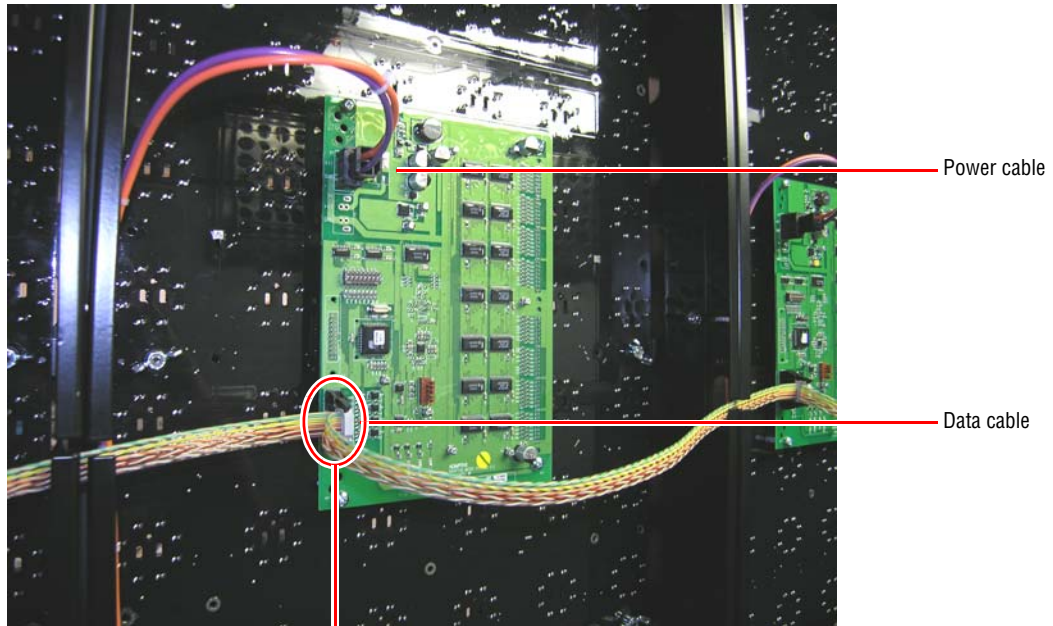

Open each side of the connector before pulling off the data cable or address plug.

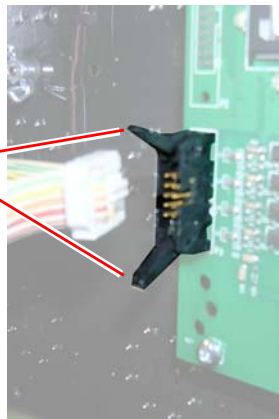

5. Loosen the six screws (two are circled below) that hold the LED driver board to the sign. Then remove the board:



6. Attach the new LED driver board to the LED panel and tighten down the six screws.
NOTE: The top of the LED driver board is marked with the word "TOP" on the front of the board.
7. Reconnect the cables to the LED driver board (P1 = Power, P2 = Address, P3 = Communication).
8. Reattach the protective panel that covers the back of this LED driver board.
9. Close the sign and apply power to the sign.

5.6 Light sensor replacement

1. Turn all sign breakers to the OFF position, except the breaker for the sign lights.



2. Locate the light sensor to be replaced.

NOTE: Three light sensors are used in the sign. All three are located next to the door of the sign in the globe.

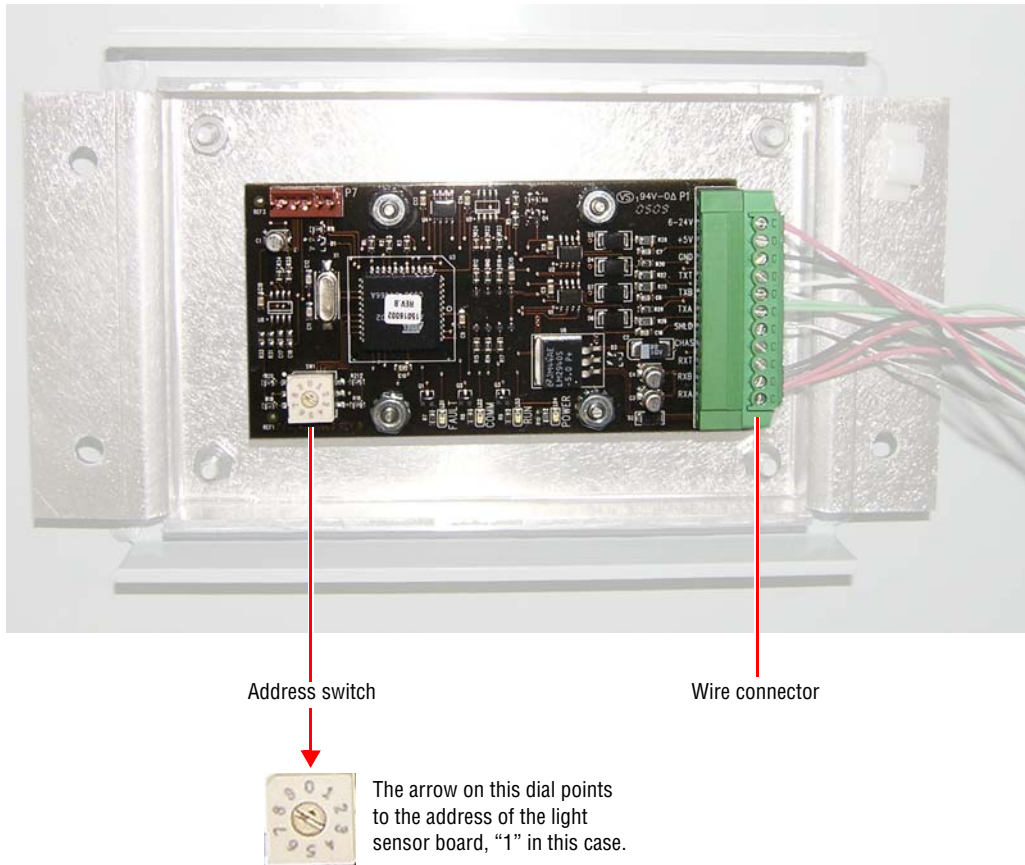
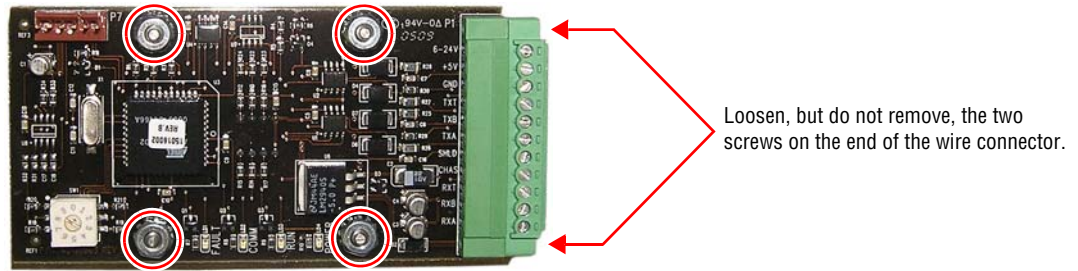

Figure 4: Light sensor

3. Set the address switch on the *replacement* light sensor board to the setting on the board that will be replaced.

4. Use a small, flat blade screwdriver to remove the wire connector from the light sensor that is being replaced. Then remove the four nuts (circled below) that hold the board to the sign:



5. Attach the replacement light sensor to the light sensor globe.