

GERBER HOMES



Elevation #4

**This Elevation can be used
with 2nd Floor Layouts B,C & E**

The Gentry II

1776 Sqft to 2414 sqft

3 & 4 BEDROOM LAYOUTS

With optional bonus room -265 SQFT

First Floor Layout 984 SF

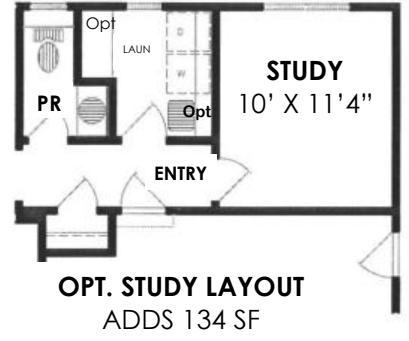
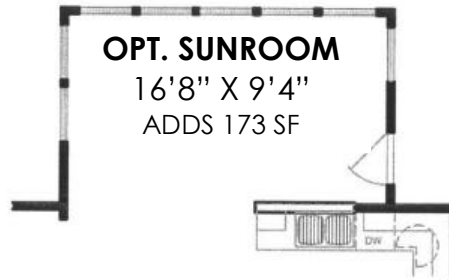

ALTERNATE FAMILY / LIVING RM LAYOUT

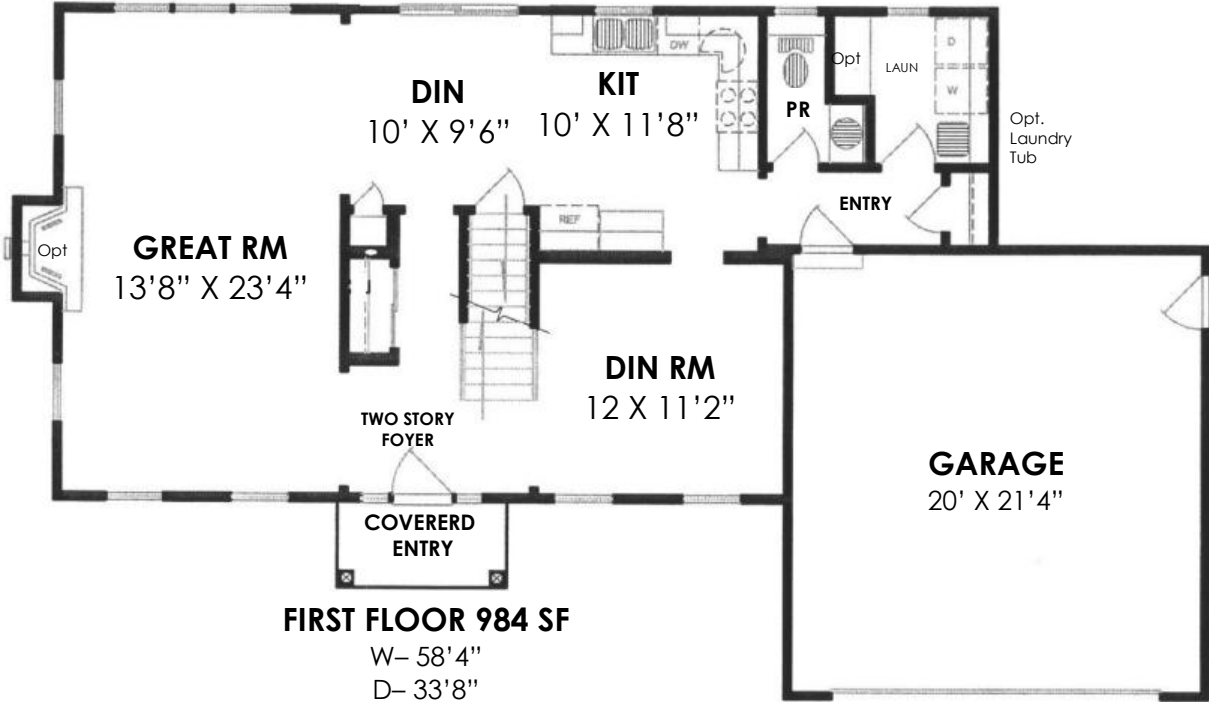
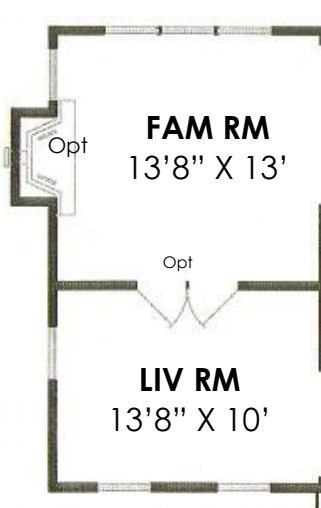

FIRST FLOOR 984 SF

W- 58'4"
D- 33'8"

3 BEDROOM LAYOUT - OPEN FOYER

Layout A

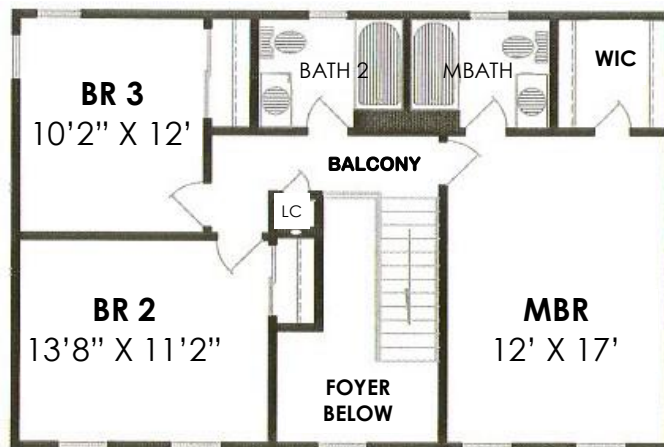

SECOND FLOOR 792 SF

W- 36'
D- 24'

This sheet is for illustrative purposes only and is not part of a legal contract. Dimensions shown are approximate and may vary from completed structure.

Layout B

Alternate Floor Layouts

Layout C

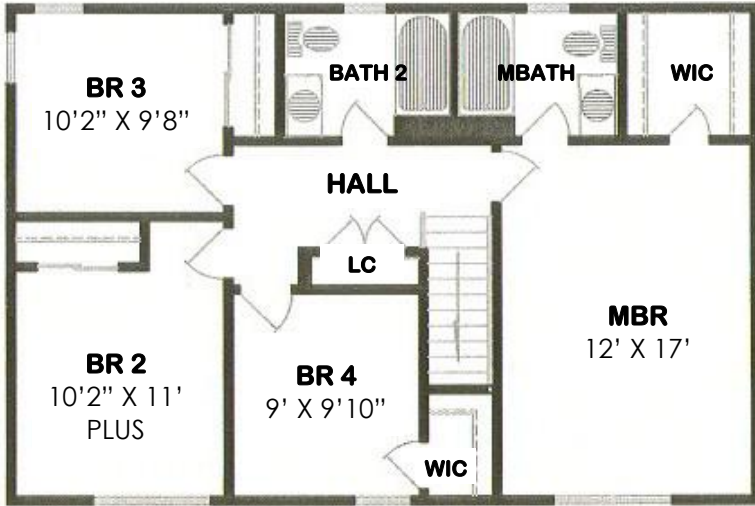

SECOND FLOOR 4BR LAYOUT 864 SF

W- 36'
D- 24'

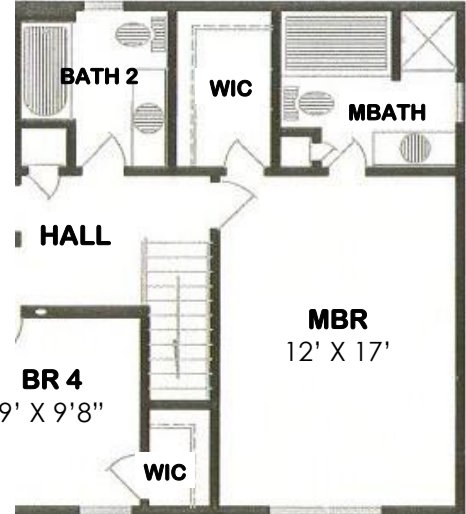

ALT LAYOUT - 4BR WHIRLPOOL 936 SF

W- 36'
D- 26'

NOTE: PLEASE NOTE THAT THE FOLLOWING LAYOUTS WILL REQUIRE THAT THE STAIRS BE SHIFTED LEFT. THIS RE-CONFIGURING MOVES THE FOYER & PANTRY TO THE RIGHT SIDE OF THE FOYER ENTRY.

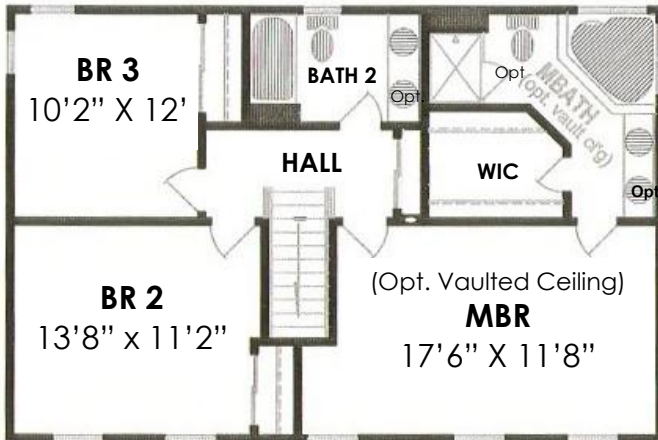

ALT LAYOUT - 3BR WHIRLPOOL 864SF

Layout D

ALT LAYOUT - 3BR w/Bonus Rm & 2nd Flr Laundry 858 SF (plus 265 SF Bonus Rm)

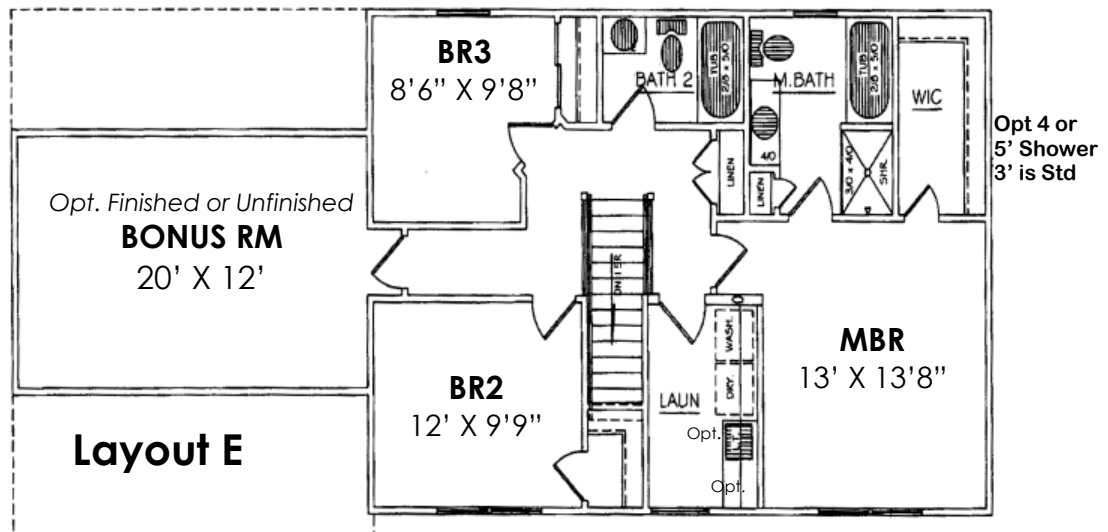

Layout E

Opt 4 or 5' Shower 3' is Std

This sheet is for illustrative purposes only and is not part of a legal contract. Dimensions shown are approximate and may vary from completed structure.

ALTERNATE ELEVATIONS

The Following Elevations can be used w/2nd Floor Layouts A & D



Elevation #2
20-1776



Elevation #5

Elevation #3



Elevation #1
20-1778-1

