



Member of the FM Global Group

Approval Standard for Flood Abatement Equipment

Class Number 2510

December 2006

Foreword

The FM Approvals certification mark is intended to verify that the products and services described will meet FM Approvals' stated conditions of performance, safety and quality useful to the ends of property conservation. The purpose of Approval Standards is to present the criteria for FM Approval of various types of products and services, as guidance for FM Approvals personnel, manufacturers, users and authorities having jurisdiction.

Products submitted for certification by FM Approvals shall demonstrate that they meet the intent of the Approval Standard, and that quality control in manufacturing shall ensure a consistently uniform and reliable product. Approval Standards strive to be performance-oriented. They are intended to facilitate technological development.

For examining equipment, materials and services, Approval Standards:

- a) must be useful to the ends of property conservation by preventing, limiting or not causing damage under the conditions stated by the Approval listing; and
- b) must be readily identifiable.

Continuance of Approval and listing depends on compliance with the Approval Agreement, satisfactory performance in the field, on successful re-examinations of equipment, materials, and services as appropriate, and on periodic follow-up audits of the manufacturing facility.

FM Approvals LLC reserves the right in its sole judgment to change or revise its standards, criteria, methods, or procedures.

Table of Contents

1. INTRODUCTION.....	1
1.1 Purpose.....	1
1.2 Scope.....	1
1.3 Basis for Requirements.....	2
1.4 Basis for Approval.....	2
1.5 Basis for Continued Approval.....	3
1.6 Effective Date.....	3
1.7 System of Units.....	3
1.8 Applicable Documents.....	3
1.9 Definitions.....	4
2. GENERAL INFORMATION.....	7
2.1 Product Information.....	7
2.2 Approval Application Requirements.....	8
2.3 Requirements for Samples for Examination.....	9
3. GENERAL REQUIREMENTS.....	9
3.1 Review of Documentation.....	9
3.2 Physical or Structural Construction Features.....	9
3.3 Components.....	10
3.4 Markings.....	10
3.5 Manufacturer's Design, Installation and Operation Instructions.....	10
3.6 Calibration.....	10
3.7 Test Facilities.....	11
3.8 Tolerances.....	11
4. PERFORMANCE REQUIREMENTS.....	11
4.1 General Components and Materials Testing.....	12
4.1.1 Examination.....	12
4.1.2 Hydrostatic Test Strength.....	12
4.1.3 System Leakage Test.....	12
4.1.4 Barrier Membrane Water Leakage.....	13
Table 4.1.4 Parameters for Ultraviolet Light Conditioning.....	13
4.1.5 Component Durability - Cycling.....	13
4.1.6 Impact and Wear Resistance.....	14
4.1.7 Abrasion Resistance.....	14
4.1.8 Vibration Resistance.....	14
Table 4.1.8 Vibration Conditions.....	15
4.1.9 Salt Spray Corrosion – Residue Build-Up.....	15
4.1.10 Environmental Corrosion Resistance.....	16
4.1.11 Hail Resistance.....	16
4.1.12 Tensile Strength, Ultimate Elongation, and Tensile Set Tests.....	17
4.1.13 Ultraviolet Light and Water Test.....	17
4.1.14 Air-Oven Aging Tests of Nonmetallic Components.....	18
4.1.15 Accelerated Aging Test.....	18
4.1.16 Compression Set Test.....	18
4.1.17 Extreme Temperatures Operation.....	19
4.1.18 Cap / Valve Locking/Supervision Ability.....	19
4.1.19 Tear and Puncture Resistance Test.....	19
Table 4.1.19: Material Testing of Non-Metallic Components.....	20
4.2 Temporary Perimeter Flood Barriers.....	20
Table 4.2.1 Perimeter Flood Barrier Performance Tests.....	21
Figure 4.2.1 Perimeter Barrier Performance Testing Flow Chart.....	22
A. Barrier Layout.....	23
Figure 4.2.2 Layout and Barrier Construction.....	23
B. Pass/Fail Criteria.....	23
4.2.1 Deployment.....	24
4.2.1.1 Deployment Validation.....	24
4.2.1.2 Deployment Team.....	25
4.2.1.3 Ground Surface.....	25

4.2.1.4	Disassembly Review	25
4.2.2	Filling	25
4.2.3	Hydrostatic and Incidental Wave – Category 1 Testing	25
4.2.3.1	Hydrostatic Head Test	26
4.2.3.2	Incidental Wave Test	26
4.2.4	Wave-Induced Hydrodynamic Load – Category 2 Testing	26
Table 4.2.2	Wave Protection Categories	26
4.2.4.1	Wave-Induced Hydrodynamic Load Test	27
4.2.5	Additional Hydrodynamic Loads – Category 3 Testing	27
4.2.5.1	Current Test	27
4.2.5.2	Overflow Test	27
4.2.5.3	Debris Impact Test	28
Figure 4.2.3	Debris Impact Test Layout	29
4.3	Opening Barriers.....	30
Table 4.3.1	Opening Flood Barrier Performance Tests.....	30
A.	Barrier Layout.....	30
B.	Pass/Fail Criteria.....	31
4.3.1	Initial Deployment.....	31
4.3.1.1	Rebuilds and Repairs	31
4.3.2	Hydrostatic Load Test.....	32
4.3.3	Dynamic Impact Load Test	32
4.4	Backflow Preventers (Grey and Black Water).....	33
4.5	Sump Pumps.....	34
4.6	Other Flood Abatement Equipment.....	34
4.7	Additional Tests.....	34
5.	OPERATIONS REQUIREMENTS.....	34
5.1	Demonstrated Quality Control Program	34
5.1.1	Quality Assurance Program	34
5.1.2	Documentation/Manual	35
5.1.3	Records	35
5.1.4	Drawing and Change Control	35
5.2	Facilities and Procedures Audit (F&PA).....	35
5.3	Installation Inspections	35
5.4	Manufacturer's Responsibilities.....	36
5.5	Manufacturing and Production Tests.....	36
5.5.1	Test Requirement No. 1 - <i>Equipment Seat Leakage</i>	36
5.5.2	Test Requirement No. 2 - <i>Equipment Hydrostatic Strength</i>	36
APPENDIX A:	Susceptibility To Leakage Test	37
A.1	Introduction	37
A.2	Test Apparatus.....	37
APPENDIX B:	Impact Resistance Test Procedure for Components for Flood Abatement Barrier Securement	39
B.1	Introduction	39
B.2	Description of Test Apparatus	39
B.3	Test Procedure	39
B.4	Evaluation of Results.....	39
APPENDIX C:	Corrosion Test Procedure for Flood Abatement Barrier Securement Components.....	40
C.1	Introduction	40
C.2	Test Procedure	40
C.3	Evaluation of Results.....	40
APPENDIX D:	Susceptibility to Hail Damage Test Procedure	41
D.1	Introduction	41
D.2	Description of Test Apparatus	41
D.3	Test Procedure	41
D.4	Evaluation of Results.....	42
APPENDIX E:	Units of Measurement	43
APPENDIX F:	Tolerances	44
APPENDIX G:	FM Approvals Certification Marks.....	45
APPENDIX H:	USACE Coastal and Hydraulics Laboratory Test Facility Description.....	47
APPENDIX I:	Test Facility Description	48

1. INTRODUCTION

1.1 Purpose

- 1.1.1 This standard describes FM Approvals requirements for flood abatement equipment for use in controlling riverine flooding conditions at depths not greater than 3 ft (0.9 m).
- 1.1.2 FM Approvals criteria may include, but are not limited to, component and system testing performance requirements, marking requirements, examination of manufacturing facility(ies), audit of quality assurance procedures, and a follow-up program.

1.2 Scope

- 1.2.1 Flood abatement equipment are categorized and designated by function (permanent, contingent, and emergency), operation (automatic, semi-automatic, and temporary), as well as the intended use of protection (i.e., perimeter and opening barriers, sump pumps and backflow preventers). This standard encompasses the design and performance requirements for flood abatement equipment for use in controlling riverine flooding conditions at depths not greater than 3 ft (0.9 m).
- 1.2.2 Consultation with FM Global Property Loss Prevention Data Sheets is required for installation of this equipment.
- 1.2.3 Due to the current state of flood abatement equipment, a comprehensive absolute standard for the testing of flood abatement components is not possible. Since each flood abatement system is unique in its operation and design, the component testing of the flood abatement system shall be performed on a case-by-case basis. The component and material testing section is intended to be used as a guideline for the manufacturer as to the scope of the test program that can be expected. Upon request for a program, and appropriate system documentation, FM Approvals shall prepare a customized evaluation program for the specific flood abatement system. While customization of the component testing is necessary, the riverine flooding simulation tests are generic and required for all flood abatement barrier type equipment. The manufacturers design calculations, stated performance requirements, as well as component functionality and reliability shall be verified.
- 1.2.4 Since flood abatement is an evolving technology, FM Approvals has determined that flood abatement equipment shall be FM Approved for specific applications. The scope of this standard encompasses the following flood abatement equipment applications:
 - 1.2.4.1 Protection with temporary perimeter barrier flood abatement equipment. These barriers function as emergency structures and are temporary. When deployed, these barriers are intended to protect the area surrounding occupancy from riverine flood conditions at depths not greater than 3 ft (0.9 m).
 - 1.2.4.2 Protection with opening barrier flood abatement equipment:

These barriers are permanent or contingent and operate as temporary or semi-automatic. A permanent barrier must be pre-installed and permanently affixed to building. A contingent barrier must be pre-installed but not permanently affixed to the building. Temporary and semi-automatic barriers require some human intervention to operate. Additional considerations are required for barriers that operate automatically. The barrier shall protect a normally closed opening from riverine flood conditions at depths not greater than 3 ft (0.9 m). Barriers that require structural analysis of the building are not included in this Standard.

The designation for a building opening shall fall into one or more of the following:

- a) Doorway
- b) Window
- c) Air brick/air vent
- d) Garage entrance/loading dock entrance

1.2.4.3 Protection with backflow preventer flood abatement equipment: More specific application and performance requirement details are to be provided with a later edition of the standard.

1.2.4.4 Protection with sump pump flood abatement equipment: More specific application and performance requirement details are to be provided with a later edition of the standard.

1.2.4.5 Protection with other flood abatement equipment: More specific application details to be provided with a later edition of the standard.

1.2.5 Approval Standards are intended to verify that the product described will meet stated conditions of performance, safety and quality useful to the ends of property conservation.

1.3 Basis for Requirements

1.3.1 The requirements of this standard are based on experience, research and testing, and/or the standards of other organizations. The advice of manufacturers, users, trade associations, jurisdictions and/or loss control specialists was also considered.

1.3.2 The requirements of this standard reflect tests and practices used to examine characteristics of flood abatement equipment for the purpose of obtaining FM Approval. Flood Abatement Equipment having characteristics not anticipated by this standard may be FM Approved if demonstrated performance is equal or superior to that required by this standard, or if the intent of the standard is met. Alternatively, flood abatement equipment that has met all of the requirements identified in this standard may not be FM Approved if other conditions which adversely affect performance exist or if the intent of this standard is not met. It is the sole opinion of FM Approvals whether Approval shall be granted.

1.4 Basis for Approval

1.4.1 Approval is based upon satisfactory evaluation of the product and the manufacturer. Examination and tests on production samples shall be performed to evaluate:

- The suitability of the product;
- The performance of the product as specified by the manufacturer and required by FM Approvals; and,
- The durability and reliability of the product.

1.4.2 An examination of the manufacturing facility(ies) and audit of quality control procedures. This examination shall be made to evaluate the manufacturer's ability to produce the product which was examined and tested, and the marking procedures used to identify the product. These examinations are repeated as part of FM Approval's Product Follow-Up Program.

1.4.3 A thorough review of the proposed flood abatement equipment "Design, Installation, Operation and Maintenance" manual.

1.5 Basis for Continued Approval

1.5.1 Continued Approval is based upon:

- The suitability of the product
- Production or availability of the product as currently FM Approved the continued use of acceptable quality assurance procedures;
- Satisfactory field experience;
- Compliance with the terms stipulated in the Master Agreement;
- Satisfactory re-examination of production samples for continued conformity to requirements; and
- Satisfactory Facilities and Procedures Audits (F&PA's) conducted as part of FM Approvals product follow-up program

1.5.2 Also, as a condition of retaining Approval, manufacturers may not change a product or service without prior written authorization by FM Approvals.

1.6 Effective Date

The effective date of an Approval standard mandates that all products tested for Approval after that date shall satisfy the requirements of the standard. Products FM Approved under a previous edition shall comply with the new version by the effective date or forfeit Approval.

The effective date of this standard is **January 1, 2007** for compliance with all requirements.

1.7 System of Units

Units of measurement used in this are United States (U.S.) customary units. These are followed by their arithmetic equivalents in International System (SI) units, enclosed in parentheses. The first value stated shall be regarded as the requirement. The converted equivalent value may be approximated. Appendix C lists the selected units and conversions to SI units for measures appearing in this standard. Conversion of U.S. customary units is in accordance with the Institute of Electrical and Electronics Engineers (IEEE)/American Society for Testing and Materials (ASTM) SI 10-97, "*Standard for Use of the International System of Units (SI): The Modern Metric System.*" Two units of measurement (liter and bar), outside of, but recognized by SI, are commonly used in the international scientific community and are used in this standard.

1.8 Applicable Documents

This standard is used in conjunction with the following standards, test methods, and practices as referenced in this standard.

ASTM Publications

American Society for Testing and Materials, 100 Barr Harbor Drive, West Conshohocken, PA 19428-2959

ASTM B117 - 2003, *Standard Practice for Operating Salt Spray (Fog) Apparatus*

ASTM D412 - 1998A, *Standard Test Methods for Vulcanized Rubber and Thermoplastic Elastomers - Tension*

ASTM D471 - 1998, *Standard Test Method for Rubber Property-Effect of Liquids*

ASTM D395 - 2003, *Standard Test Methods for Rubber Property - Compression Set*

ASTM D573 - 2004, *Standard Test Method for Rubber - Deterioration in an Air Oven*

ASTM D1242 - 1995, *Standard Test Method for Abrasion*

ASTM D1790 - 2002, *Standard Test Method for Brittleness Temperature of Plastic Sheeting by Impact*

ASTM D1922 - 2006A, *Standard Test Method for Propagation Tear Resistance of Plastic Film and Thin Sheeting by Pendulum Method*

- ASTM D3273 - 2000, *Standard Test Method for Resistance to Growth of Mold on the Surface of Interior Coatings in an Environmental Chamber*
- ASTM D5602 - 2006, *Standard Test Method for Static Puncture Resistance of Roofing Membrane Specimens*
- ASTM D5635 - 2004A, *Standard Test Method for Dynamic Puncture Resistance of Roofing Membrane Specimens*
- ASTM D6382 - 2005, *Standard Practice for Dynamic Mechanical Analysis and Thermogravimetry of Roofing and Waterproofing Membrane Material*
- ASTM E290 - 2004, *Standard Test Methods for Bend Testing Of Material for Ductility*
- ASTM G154 - 2004, *Standard Practice for Operating Fluorescent Light Apparatus for UV Exposure of Nonmetallic Materials*
- ASTM G155 - 2005, *Standard Practice for Operating Xenon Arc Light Apparatus for Exposure of Non-Metallic Materials*
- ASTM SI10 - 2002, *American National Standard for Use of the International System of Units (SI): The Modern Metric System*

FM Global

FM Global, 75 Remittance Drive Suite #6182, Chicago, IL 60675-6182

FM Global Property Loss Prevention Data Sheets

FM Approvals

1151 Boston-Providence Turnpike, P.O. Box 9102, Norwood, MA 02062 USA
<http://www.fmglobal.com/approvals/resources/standards.asp>

FM Approvals' Approval Standards
 Quality Assurance Guidelines For Manufacturers of FM Approved and Specification Tested Products,
 October 2003

International Standards Organization

International Standards Organization, , 1 rue de Varembé, Case Postale 56, CH-1211 Geneve 20, Switzerland

- ISO 9001 - 1994, *Quality Systems - Model for quality assurance in design, development, production, installation, and servicing*
- ISO 9002 - 1994, *Quality Systems - Model for quality assurance in production, installation, and servicing*
- ISO 17025 - 1999, *General Requirements For The Competence of Testing and Calibration Laboratories*

United States Army Corp of Engineers

United States Army Corp of Engineers (USACE), Engineering Research and Development Center (ERDC)

Standardized Testing Protocol for Evaluation of Expedient Floodfight Structure, June 22, 2004

1.9 Definitions

For purposes of this Standard, the following terms apply.

Accepted

This term refers to installations acceptable to the authority having jurisdiction and enforcing the applicable installation rules. When the authority is FM Global, such locations are termed "FM Global Accepted." Acceptance is based upon an overall evaluation of the installation. Factors other than the use of FM Approved equipment impact upon the decision to accept the equipment. Acceptance is not a characteristic of a product. It is installation specific. A product accepted for one installation may not be acceptable elsewhere. (Contrast with FM Approved).

Automatic Device

Any device that operates without any additional intervention (i.e. a flood door that closes when a water level meter reads a predetermined level) or a permanent passive device such as a continuous flood wall or levee.

Contingent flood proofing devices

Any device that requires some form of installation, activation, or other preparation in the event of a flood (i.e. watertight doors that are manually closed).

Demountable Perimeter Flood Barriers

These barriers function as emergency structures, are temporary, and require permanent or precast foundations. When deployed, these barriers are intended to protect the area surrounding occupancy from riverine flood conditions at depths not greater than 3 ft (0.9 m).

Deployment Time

The amount of time required for setup and operation of the flood abatement equipment. For the purpose of this standard the deployment time as well as the amount of personnel and supplies to reach said time shall be specified by the manufacturer in the installation manual.

Door Panels

Any panel, permanent or otherwise, which provides partial coverage of an exterior or interior door opening with the principle function of prevention of flood water passage.

Dry-Side

The side of the wave basin protected by the flood barrier.

Emergency Flood Proofing Devices

Any device that can be fitted, installed, or otherwise put in place in a relatively short period of time during a flood event (i.e. sandbags).

Flood Doors

Any door, permanent or otherwise, which provides complete coverage of exterior or interior door opening with the principle function of prevention of flood water passage.

Flood Vents

Any vent, permanent or otherwise, provided with the principle function of water transmission for the relief of hydrostatic pressure on a structure.

Flood Walls

Any wall, permanent or otherwise, provided with the principle function of prevention of the flooding of adjacent land.

FM Approvals Certification Mark

The FM Approvals Certification Mark is detailed in Appendix G. Its use is mandatory on all FM Approved systems. These registered marks cannot be used except as authorized by FM Approvals via the granting of Approval to a specific product. For flood abatement equipment systems, the FM Approvals Certification mark shall be placed on the system placard and not on individual components unless those components have undergone a separate evaluation to the applicable standards.

FM Approved

This term refers to products FM Approved by FM Approvals. Such products are listed in the Approval Guide, a publication of FM Approvals, issued annually, or one of the supplements. All products so listed have been successfully examined by FM Approvals and their manufacturers have signed and returned a Master Agreement to FM Approvals. This contract obligates the manufacturer to allow re-examination of the product and audit of facilities and procedures at FM Approvals' discretion. It further requires the manufacturer not to deviate from the as-FM Approved configuration of the product without review by and agreement of FM Approvals. Approval is product specific.

Manual Device

Any device that requires significant intervention to operate in the desired manner (i.e. sandbags that need to be filled then stacked).

Miscellaneous Category

Any product designed to prevent the passage of water, regulate the flow of water, or otherwise protection a structure or adjacent land from flood water that is not covered in another category.

Nationally Recognized Testing Laboratory (NRTL)

A laboratory which is listed and recognized by the United States Department of Labor, Occupational Safety & Health Administration's (OSHA) Directorate of Science, Technology, and Medicine program. The program recognizes private sector organizations as NRTL's, and recognition signifies that an organization has met the necessary qualifications specified in the regulations for the Program. The NRTL determines that specific equipment and materials ("products") meet consensus-based standards of safety to provide the assurance, required by OSHA, that these products are safe for use in the U.S. workplace.

Occupancy Drainage Device

Any device, permanent or otherwise, provided with the principle function of removal of water present in a structure or prevention of flood water for entering the structure.

Opening Barrier

Any device, permanent or otherwise, provided with the principle function of prevention of flood water passage through the opening in a building. A building opening refers to any penetration where water can flow such as doors, windows, air bricks/vent bricks, portals etc.

Overtopping

The action of water flowing over the top of the flood barrier as a result from a hydrodynamic or hydrostatic wave test.

Permanent Flood Proofing Devices

Any device that once installed requires no additional action taken in the event of a flood (i.e. floodwalls).

Product Deflection

The amount the seal of the temporary flood barrier moves from its original location prior to testing. Deflection is measured from the original location of the product along its base where it forms the seal, on the river side of the barrier.

Rate of Leakage

The rate at which water moves past or through the temporary flood barrier from the river side of the barrier to the dry side of the barrier, expressed as gallons per minute per foot length of barrier seal.

Riverine Flood Conditions

Flooding of or produced by a river causing both water and sediments to be transported onto a flood plain.

River-Side

The side of the basin that imposes the flood water, also referred to as the wet-side.

Sandbags

Any bag, filled with sand or other material, provided with the principle function of prevention of the flooding of adjacent land.

Seal

The location where the product meets the ground or wall of the basin to create a barrier to prevent water from moving from the wet side of the basin to the dry side. Depending on the design and construction of the flood barrier, a seal can be made between different components or sections of the flood barrier.

Semi-Automatic Device

Any device that requires human intervention to activate the desired function (i.e. depressing the close button on a roll-up door).

Temporary Perimeter Flood Barrier

These barriers function as emergency structures, are temporary, and do not require permanent or precast foundations. When deployed, these barriers are intended to protect the area surrounding occupancy from riverine flood conditions at depths not greater than 3 ft (0.9 m).

Wall Panels

Any panel, permanent or otherwise, which provides complete coverage of exterior or interior wall penetrations with the function of prevention of flood water passage.

2. GENERAL INFORMATION

2.1 Product Information

2.1.1 Flood abatement equipment are categorized and designated by function (permanent, contingent, and emergency) and operation (automatic, semi-automatic, and temporary). FM Approvals defines protection with the following flood abatement equipment.

- Temporary perimeter flood barriers
- Opening barrier flood abatement equipment
- Backflow preventer flood abatement equipment
- Sump pump flood abatement equipment

2.1.2 In order to meet the intent of this standard, Flood Abatement Equipment shall be examined on a model-by-model, type-by-type, manufacturer-by-manufacturer, and plant-by-plant basis. This is predicated on the basis that identical designs, fabricated in identical materials by different manufacturers have been seen to perform differently in testing. Sample Flood Abatement Equipment, selected in conformance to this criterion, shall satisfy all of the requirements of this standard.

2.2 Approval Application Requirements

To apply for an Approval examination the manufacturer, or its authorized representative, should submit a request to:

Hydraulics Group Manager
FM Approvals
743A Reynolds Road
West Glocester, RI 02814 U.S.A.

The manufacturer shall provide the following preliminary information that gives a full and correct specification of the critical construction aspects of the flood abatement equipment system with any request for Approval consideration. One copy (except as noted) of the following documentation as it pertains to the Approval request should be assembled in an organized manner. All documents shall identify the manufacturer's name, document number or other form of reference, title, date of last revision, and revision level.

Test programs will be scheduled only upon receipt of all material listed herein. All foreign language documents shall be provided with English translation.

- 2.2.1 Marketing/Ordering Literature - Showing general specifications and functions of the system. These are used in the creation of an Approvals project and may be attached to the final Approval Report.
- 2.2.2 Model Number Breakdown - A specification or drawing showing all system variations and options to be examined.
- 2.2.3 Instruction Manual - Design, installation, operation, and maintenance instructions.
- 2.2.4 Quality Control Procedures - Document(s) detailing routine testing and final inspection procedures: receiving inspection; in-process inspection; final inspection, and calibration of measuring and testing equipment used. In addition, procedures must detail the system acceptance testing once the flood abatement equipment system is installed.
- 2.2.5 Documentation Control Specification - Proposed method of controlling critical documents which may be identified in the Documentation Section of the Approval Report. These drawings shall be listed in the report issued at the conclusion of the Approval Program. FM Approvals shall be notified of changes to these documents via Form 797, "Approved Product/Specification-Tested Revision Report or Address/ Main Contact Change Report".
- 2.2.6 Production Drawings - The following drawings shall be provided:
 - Electrical schematic(s)
 - Final assembly drawings and parts lists sufficient to detail primary components (all), operator controls, and their locations;
 - Complete set of mechanical drawings for all machined parts;
 - Complete part specifications (including manufacturer's model numbers, size, ratings, etc.) for all purchased parts;
 - Specification sheets for all parts/components;
 - Drawings showing all construction details;
 - Product label drawing(s) showing all required marking information. The label drawing shall show the proposed label location on the equipment and artwork showing the manufacturer's name, address, model and serial numbers, equipment ratings, warning markings, and the FM Approval Certification Mark, (see Appendix F).
- 2.2.7 The number and location of manufacturing facilities.

2.3 Requirements for Samples for Examination

Following set-up and authorization of an Approval examination, the manufacturer shall prepare a system, its components and materials for examination and testing. Sample requirements are to be determined by FM Approvals following review of the preliminary information. Sample requirements may vary depending on design features, results of prior testing, and results of the foregoing tests. It is the manufacturer's responsibility to submit samples representative of production. Any decision to use data generated utilizing prototype components or prototype systems is at the sole discretion of FM Approvals.

3. GENERAL REQUIREMENTS

3.1 Review of Documentation

During the initial investigation and prior to physical component, material or hydrostatic testing, the manufacturer's specifications, technical data sheets, and design details shall be reviewed to assess the ease and practicality of installation and use. The system and its components shall be capable of being used within the limits of the Approval investigation.

3.2 Physical or Structural Construction Features

- 3.2.1 The manufacturer shall provide a diagram or schematic drawing of the system which indicates the system operating parameters.
- 3.2.2 The test program requirements shall be based on assembly and manufacturing drawings supplied by the manufacturer prior to the start of testing. If, following the results of testing, additional hardware is required, the test program will be revised as necessary.
- 3.2.3 Air / Nitrogen / other gas cylinder(s) for pressurized seal systems shall meet the applicable requirements of either the ASME Boiler and Pressure Vessel Code, Section VII; U.S. Department of Transportation (D.O.T), Title 49, Code of Federal Regulations, Parts 171 through 180; or equivalent national standard of the country of use, reference section 4.9.
- 3.2.4 Hydrostatic strength of components shall be based on 150 percent of the maximum system operating pressure.
- 3.2.5 Suitability of materials along with certification of materials compatibility shall be submitted for review. Suitability of materials with the expected environmental atmospheres along with certification of material and environment compatibility shall be submitted for review.
- 3.2.6 The Approval examinations for use in the following types of unapproved electrical components shall be included within the scope of the FM Approvals project examination.
- 3.2.7 All materials used in flood abatement equipment shall be suitable for the intended application. Flood abatement equipment shall be constructed of corrosion resistant materials. When unusual materials are used, special tests may be necessary to verify their suitability.

3.3 Components

A component of the flood abatement equipment product covered by this standard shall comply with the requirements for that component, and shall be used in accordance with its rated values and other limitations of use. A component need not comply with a specific requirement that involves a feature or characteristic not needed in the application of the component in the flood abatement equipment product covered by this standard.

At a minimum, components required for the flood abatement equipment shall be designed or selected for maximum long term reliability. Flood abatement equipment design should take into account the possibility of component failure and the potential for that failure to impair the effectiveness of the system. Such impairments shall be minimized through failsafe, redundant component, over-design, de-rating, or other means demonstrating equivalent reliability.

3.4 Markings

3.4.1 A permanently-marked, legible, corrosion-resistant nameplate shall be securely attached to the equipment where practical and it shall be easily visible. The nameplate shall include the minimum following information:

- Manufacturer's name or trademark;
- Model identification;
- System ratings;
- Equipment operating ratings;
- Serial number or other traceable code markings;
- FM Approvals Certification Mark, (see Appendix G); and,
- Manufacturing location source code where necessary.

3.4.2 Any other pertinent marking information required by the referenced standards or other national or international standard to which the system is manufactured shall be permanently marked on a suitable data plate.

3.4.3 The model or type identification shall correspond with the manufacturer's catalog designation and shall uniquely identify the product as FM Approved. The manufacturer shall not place this model or type identification on any other product unless covered by a separate agreement.

3.5 Manufacturer's Design, Installation and Operation Instructions

The manufacturer shall provide complete instructions and any assistance required to properly design, install, operate, and maintain the equipment. Such documentation shall be furnished by the manufacturer with the flood abatement equipment and shall be submitted to FM Approvals as a part of the examination of a system.

3.6 Calibration

All equipment used to verify the test parameters shall be calibrated within an interval determined on the basis of stability, purpose, and usage of the equipment. For testing conducted at locations other than FM Approvals, a copy of the calibration certificate for each piece of test equipment is required for FM Approvals records that indicate that the calibration was performed to standards traceable to the National Institute of Standards and Technology (NIST) or to other acceptable reference standards by an accredited ISO 17025 calibration laboratory. The test equipment must be clearly identified by label or sticker showing the last date of the calibration and the next due date. In addition, a copy of the ISO 17025 accreditation certificate for the calibration laboratory is required for FM Approvals records.

The calibration of recently purchased new equipment is also required. Documentation indicating either the date of purchase or date of shipment, equipment description, model and serial number is required for identification. The period from the time the equipment was put into service to the date of testing must be within an interval that does not require the equipment to be calibrated as determined on the basis of the parameters mentioned above.

3.7 Test Facilities

If review of all required information indicates suitability for Approval, testing of sample Flood Abatement Equipment for specific occupancy protection will be scheduled. The range of component, material and hydrostatic tests to be conducted shall be specified by FM Approvals. Testing shall be conducted at an FM Approvals facility as well as other National Recognized Testing Laboratories (NRTL). The manufacturer shall provide facilities and all properly calibrated instrumentation required to perform the tests deemed necessary by FM Approvals if the testing cannot be conducted at an FM Approvals facility. If other standards are contemplated, they should be forwarded to FM Approvals for review and acceptance prior to the generation of the test program. The manufacturer shall also provide personnel to install and operate the flood abatement equipment. For testing not conducted at an FM Approvals facility, a representative of FM Approvals shall witness all the tests and shall receive copies of the data and calibration certificates.

3.8 Tolerances

Tolerances on units of measure shall be as described in Appendix F, unless otherwise specified.

4. PERFORMANCE REQUIREMENTS

The performance requirements are composed of two parts: 1) components and materials hydrostatic and hydrodynamic examination and 2) performance requirements testing. Due to the current state of flood abatement equipment technology, a comprehensive absolute standard for the testing of flood abatement equipment is not possible. Since each flood abatement equipment barrier can be unique in its operation and design, the component and material testing of the flood abatement equipment system shall be performed on a case-by-case basis. The component and material testing section is intended to be used as a guideline for the manufacturer as to what type of test program can be expected. Performance requirement testing may be conducted for an individual component, component assembly or as an entire system, as deemed necessary at the sole opinion of FM Approvals. Electrical components that require a hazardous location rating shall be evaluated under the scope of the Approval examination, with evaluations and required testing performed by the FM Approvals Electrical Group. Upon request for a program, and appropriate system documentation, FM Approvals will prepare a customized evaluation program for the specific flood abatement equipment system. While customization of the component testing is necessary, the hydrostatic and hydrodynamic examination and performance requirements testing are generic for all temporary perimeter barrier systems. The manufacturer's design calculations, stated performance requirements, as well as component functionality and reliability shall be verified.

4.1 General Components and Materials Testing

As the materials of construction and mode of operation will vary significantly between manufacturers, specific material tests shall be assigned on a case by case basis. The actual material testing performed on the flood abatement equipment and associated components undergoing Approval examination shall be assigned at the sole discretion of FM Approvals.

The materials testing described in Section 4.1 may be waived at the discretion of FM Approvals if prior testing has been completed by an OSHA Directorate of Science, Technology and Medicine certified NRTL (National Research and Testing Laboratory). This testing shall have been carried out as described in the applicable ASTM Standard and completed with ISO 17025 calibrated equipment.

In addition, certificates of compatibility from the material manufacturer shall be submitted for the materials to be used at the prescribed temperature and pressure ranges. All testing shall be conducted at a normal ambient temperature of 70 ± 5 °F (21.1 ± 2.8 °C) unless otherwise specified. After testing, the barrier and/or components shall be visually inspected to meet the stated requirements and, if deemed, necessary, shall be subjected to any of the appropriate tests outlined in this Approval Standard.

4.1.1 Examination

4.1.1.1 Requirements

The flood abatement barrier system shall conform to the manufacturer's drawings and specifications and to Approval requirements.

4.1.1.2 Test/Verification

A flood abatement barrier system, and all its individual components, representative of the manufacturer's final production equipment to be FM Approved shall be examined and compared to drawings and engineering specifications. It shall be verified that the representative system sample conforms to the physical and structural requirements described in Section 3, General Requirements.

4.1.2 Hydrostatic Test Strength

4.1.2.1 Requirements

Pressure retaining flood abatement equipment barrier bodies, such as bladders, shall withstand 150 percent of the maximum system operating pressure, without rupture, cracking or permanent distortion.

4.1.2.2 Test/Verification

Barrier bodies of each size shall be subjected to a test pressure of 150 percent of the maximum system operating pressure, for five minutes. The test medium shall be the medium used during operation. No rupture, cracking or permanent distortion of the component body is allowed. After this test the component shall be fully operable.

4.1.3 System Leakage Test

4.1.3.1 Requirements

All pressure retaining components such as caps, fill ports, control, relief valves, and bladders shall be leak tight when subjected to a hydrostatic test pressure of 120 percent of the maximum system operating pressure.

4.1.3.2 Test/Verification

With the inlet side open to atmosphere, the upstream side of each size cap, fill port, control and relief valve shall be subjected to pressure of 120 percent of the maximum system operating pressure to prove the sealing ability. The test medium shall be the medium used during operation. The test pressure shall be held for five minutes with no leakage allowed.

4.1.4 Barrier Membrane Water Leakage

4.1.4.1 Requirement

The flood abatement equipment barrier material shall not show evidence of water leakage when subjected to the FM Approvals Water Leakage Test Apparatus (see Appendix A).

4.1.4.2 Test/Verification

An 18 in. (457 mm) diameter sample shall be prepared with a field seam and/or penetration detail included where appropriate, and running along the diameter of the sample. The sample shall be conditioned (weathered) for 1000 hours in ultraviolet light in accordance with ASTM G155-05a *Standard Practice for Operating Xenon Arc Light Apparatus for Exposure of Non-Metallic Materials* with the following parameters:

Table 4.1.4 Parameters for Ultraviolet Light Conditioning

Filter:	Daylight
Irradiance:	0.35 W/m ² /nm
Wavelength:	340 nm
Temperature:	63±2.5 °C
Relative Humidity:	30±5 percent

After 1000 hours of exposure, the 18 in. (457 mm) samples shall be cut to a 10 in. (254 mm) diameter size and placed in the leakage test apparatus. There shall be no signs of water leakage during or at the end of the 168 hour period. The sample shall be maintained at ambient conditions.

4.1.5 Component Durability - Cycling

4.1.5.1 Requirements

Any ancillary components of the system with moving parts used as part of a flood abatement equipment system shall not show excessive wear or damage after 500 cycles of operations.

4.1.5.2 Tests/Verification

The sample component shall be cycled 500 times through its operational requirements, depending on its normal expected operation, through its full open to close and close to open positions, or its full range of travel. After testing, the barrier and/or components shall be visually inspected to meet the stated requirements and, if deemed, necessary, shall be subjected to any of the appropriate tests outlined in this Approval Standard.

4.1.6 Impact and Wear Resistance

4.1.6.1 Requirement

Flood abatement equipment plastic securement components are subject to stress, climatic conditions, and impact from foot traffic and equipment during the construction periods and life span of the barrier. These conditions may result in degradation of the plastic component(s). Therefore, the plastic component(s) shall not craze or show signs of degradation when subjected to the FM Approvals Impact Resistance Test Procedures (see Appendix B).

4.1.6.2 Test/Verification

- A. Each plastic component shall be placed in a refrigeration chamber and exposed to a temperature of 10°F (-12°C) for a 24 hour period. The component(s) shall be removed from the chamber and immediately installed as described in the manufacturer's instruction manual. When installed, the maximum force or torque specified by the manufacturer shall be used. The plastic component(s) shall not show crazing, signs of cracking, or permanent distortion.
- B. The 24-hour refrigeration cycle shall be repeated for each barrier membrane assembly sample [12 in. × 12 in. (0.3 m × 0.3 m) size]. A sample shall be removed from the chamber and its plastic component shall resist damage from an impact of 50 ft/lbs (6.8 kg/m) using the FM Approvals Impact Resistance test procedures (see Appendix B). A minimum of three drops of the impactor is required. After the tests, the plastic component(s) shall not fracture or show any signs of crazing.

4.1.7 Abrasion Resistance

4.1.7.1 Requirement

The ability of the flood abatement equipment barrier construction material, such as membrane, shell, etc., to resist normal wear from anchoring components shall be verified. After testing to the requirements of Section 4.1.7.2 the material shall not show any signs of wear that would cause a catastrophic failure of the flood abatement system.

4.1.7.2 Tests/Verification

The material to be tested shall be orientated and set-up in the same manner as the end-use application. A Norton standard 5 × 2 × 1/2 in. (130 × 50 × 15 mm) nominal size abrasion wheel with the designation 37C36-KVK shall be moved to and fro for 3000 cycles along the material. The wheel shall be prevented from rotating and shall exert on the material its full weight plus half of the 1 lb (0.5 kg) weight of the moving arm. The frequency of cycles shall not exceed 30 per minute. The contact surface of the portion of the abrasion wheel utilized shall be unused at the start of the test. After the 3000 cycles, the material shall be visually inspected for signs of wear that would cause a catastrophic failure of the flood abatement system.

4.1.8 Vibration Resistance

4.1.8.1 Requirements

The securement component, or component assemblies, shall withstand vibration without loosening, separation, or excessive wear to the securement components as a result of this test.

4.1.8.2 Tests/Verification

One of each type or size of each component under examination shall be attached to a mounting plate, by the method of the manufacturer's suggested installation procedure. Therefore the component or component assembly shall be subjected to the normally installed force, torque, etc. The mounting plate shall be attached to the table of a vibration machine so that the component or component assemblies are vibrated vertically.

The test sample shall be subjected to the vibration sequence outlined in Table 4.1.8. For the variable frequency conditions, the frequency shall be varied with a cycle period of 25 ± 5 seconds. If one or more resonant point(s) is detected during the variable frequency vibration, the component, or component assemblies shall be vibrated for the remainder of the five hours at such frequency(ies) for a period of time proportionate to the number of resonant frequencies. Otherwise the component or component assemblies shall be subjected to each vibration condition for a period of 5 hours (25 hours total).

Table 4.1.8 Vibration Conditions

<i>Total Displacement/Stroke</i> <i>Inch</i>	<i>(mm)</i>	<i>Frequency</i> <i>Hz</i>	<i>Time</i> <i>Hours</i>
0.020	(0.51)	28	5
0.040	(1.04)	28	5
0.150	(3.81)	28	5
0.040	(1.04)	18 to 37 (variable)	5
0.070	(1.78)	18 to 37 (variable)	5

4.1.9 Salt Spray Corrosion – Residue Build-Up

4.1.9.1 Requirements

In order to evaluate the resistance to corrosion of the component or component assembly, such as might be experienced by dissimilar materials in contact over long periods of time; the component shall withstand a timed exposure to a salt spray atmosphere. When tested as detailed in Section 4.1.9.2 (Salt Spray - Corrosion), visual evidence of severe deterioration or impending failure of any component shall constitute failure. Tested samples shall remain fully functional and exhibit no corrosion, galvanic action, loss of legibility of markings, or separation of protective coatings which would impair future functionality. Superficial discoloration with no substantial attack of the underlying material shall be acceptable. There shall be no corrosion on any surface, other than corrosion that is easily removed from the surface with a wet cloth. Additionally, any metallic part that has a corrosion resistant coating shall remain intact during the test. Corrosion resistant material specifications shall be submitted for review.

4.1.9.2 Test/Verification

One previously untested component, component assembly, or system shall be assembled per the manufacturer's instructions. If necessary, the component shall be sealed with a non-reactive material (e.g., plastic cap) so as to prevent the introduction of salt fog into the component. The component shall be supported and oriented in its intended installation position. The sample component shall be exposed to salt spray (fog) as specified by ASTM B117, *Standard Practice for Operating Salt Spray (Fog) Apparatus* with the exception of the salt solution. The salt solution shall consist of 20 percent (by weight) of common salt (sodium chloride) dissolved in deionized water with a pH between 6.5 and 7.2 and specific gravity from 1.126 to 1.157.

The sample shall be exposed for a period of 240 hours.

Following the exposure to the salt fog, the sample shall be removed from the test chamber and permitted to air dry for a two- to four-day drying period. Following this drying period, the component shall be fully operable under simulated operating conditions. After testing, the barrier and/or components shall be visually inspected to meet the stated requirements and, if deemed, necessary, shall be subjected to any of the appropriate tests outlined in this Approval Standard.

4.1.10 Environmental Corrosion Resistance

4.1.10.1 Requirement

Mechanical fasteners which secure are subject to condensation, moisture migration, and chemical reaction with barrier materials. The fastener, distribution plate, or batten bar anchor shall not develop corrosion on more than 15 percent of its surface area after 15 cycles in the FM Approvals Corrosion Test outlined in Appendix C.

4.1.10.2 Test/Verification

Each specimen shall be exposed to air saturated with water vapor at 104°F (40°C) containing a mild concentration of sulfur dioxide for 8 hours, followed by a drying period of 16 hours at room temperature. After each drying cycle, the specimen shall be inspected and signs of corrosion shall be recorded.

The 24-hour cycle shall be repeated 15 times and the corrosion percentage shall be recorded.

To evaluate the corrosion increase after Cycle 1 thru Cycle 15, the specimen shall be mounted to blue painted sheet coupons.

4.1.11 Hail Resistance

4.1.11.1 Requirement

The flood abatement equipment barrier components and materials shall be able to withstand the effects of hail. Components and materials, including joints and seams shall show no evidence or signs of blistering, chipping, cracking, crazing, delamination, internal separation, peeling, puncture, rupture or splitting when tested by the FM Approvals Simulated Hail Damage Test Procedures. Severe degradation (cracking, crushing, etc.) of the flood abatement equipment barrier component or material itself is reason for failure.

4.1.11.2 Test/Verification

The flood abatement equipment barrier components and materials combination shall resist hail damage from either of the FM Approvals Simulated Hail Damage test procedures (see Appendix D). A minimum of ten drops of the impactor is required, five of which shall be conducted on a fabricated seam or securement detail where appropriate. After the tests, there shall be no evidence of flood abatement equipment damaged when examined.

4.1.12 Tensile Strength, Ultimate Elongation, and Tensile Set Tests

4.1.12.1 Requirements

Elastomers used in flood abatement barrier component construction shall have a tensile strength of not less than 500 psi (3455 kPa), an ultimate elongation of not less than 100 percent, and a tensile set of not more than 19 percent. Parts constructed with material other than silicone rubber shall have a tensile strength of not less than 1500 psi (103.4 bar) and at least 200 percent ultimate elongation. Tensile strength, ultimate elongation, and tensile set shall be determined in accordance with ASTM D 412, *Standard Test Methods for Vulcanized Rubber and Thermoplastic Elastomers Tension*, Method A with exceptions as stated in Section 4.1.12.2.

4.1.12.2 Tests/Verification

Tensile strength, ultimate elongation, and tensile set shall be determined in accordance with ASTM D 412, *Standard Test Methods for Vulcanized Rubber and Thermoplastic Elastomers - Tension*, Method A, with the exception that, for tensile set determinations, the elongation shall be maintained for 3 minutes, and the tensile set shall be measured 3 minutes after release of the specimen. The elongation of a specimen for a tensile set determination shall be such that the 1 in. (25 mm) spacing of the benchmarks increases to 3 in. (76 mm). If a specimen breaks outside the benchmarks, or if either the measured tensile strength or ultimate elongation of the specimen is less than the required value, an additional specimen shall be tested, and those results shall be considered final. Results of tests for specimens that break in the curved portion just outside the benchmarks shall be permitted to be accepted if the measured strength and elongation values are within the minimum requirements.

4.1.13 Ultraviolet Light and Water Test

4.1.13.1 Requirements

Flood abatement barrier non-metallic components shall be exposed to ultraviolet light and water for 720 hours in accordance with Table X3.1, Condition 1, of ASTM G 155-05a, *Standard Practice for Operating Xenon Arc Light Apparatus for Exposure of Non-Metallic Materials*. At the conclusion of the test, there shall be no cracking or crazing of the component. Following exposure, all functions such as securement, adjustment, etc., shall operate properly.

4.1.13.2 Tests/Verification

A sample of each non-metallic component shall be exposed to ultraviolet light and water for 720 hours in accordance with Table X3.1, condition 1 of ASTM G155, *Standard Practice for Operating Xenon Arc Light Apparatus for Exposure of Non-Metallic Materials*. During each operating cycle, each sample shall be exposed to light and water spray for 18 minutes and to only light for 102 minutes (total 120 minutes). The air temperature within the apparatus during operations shall be $109 \pm 4.5^{\circ}\text{F}$ ($43 \pm 2.5^{\circ}\text{C}$) and the relative humidity 30 ± 5 percent. The component shall be inspected for cracking and crazing after 360 hours. If no cracking or crazing is apparent, the exposure shall continue for the full 720 hours. After testing, the barrier and/or components shall be visually inspected to meet the stated requirements and, if deemed, necessary, shall be subjected to any of the appropriate tests outlined in this Approval Standard.

4.1.14 Air-Oven Aging Tests of Nonmetallic Components

4.1.14.1 Requirements

All flood abatement barrier nonmetallic components, other than rubber gaskets, shall be subjected to air-oven aging tests at 158°F (70°C). There shall be no cracking or crazing as a result of this test.

4.1.14.2 Test/Verification

Flood abatement barrier nonmetallic components shall be subjected to air-oven aging tests for 180 days at 158°F (70°C), and then allowed to cool at least 24 hours in air at 74°F (23°C) at 50 percent relative humidity. At the conclusion of the test, the barrier nonmetallic components shall be inspected for cracking or crazing. After testing, the barrier and/or components shall be visually inspected to meet the stated requirements and, if deemed, necessary, shall be subjected to any of the appropriate tests outlined in this Approval Standard.

4.1.15 Accelerated Aging Test

4.1.15.1 Requirements

Flood abatement barrier component seals formed using a rubber material or synthetic elastomer shall be subjected to an accelerated aging test. Following the test the material shall have not less than 80 percent of the as-received tensile strength and 50 percent of the as-received ultimate elongation.

4.1.15.2 Tests/Verification

Specimens shall be prepared in the same manner as for tensile strength and ultimate elongation tests outlined in Section 4.1.12, except that benchmarks spaced 1 in. (25 mm) apart shall be stamped on the specimens after the test exposure. Specimens shall be tested at 212°F (100°C) for 70 hours in accordance with ASTM D 573, *Standard Test Method for Rubber - Deterioration in an Air Oven*. After exposure samples shall be tested in accordance with ASTM D 412, *Standard Test Methods for Vulcanized Rubber and Thermoplastic Elastomers C Tension*.

4.1.16 Compression Set Test

4.1.16.1 Requirements

For all flood abatement barrier rubber components, a compression set of the material in the as-received condition shall be not more than 15 percent, as determined in Section 4.1.16.2.

4.1.16.2 Tests/Verification

Testing shall be conducted in accordance with ASTM D 395, *Standard Test Methods for Rubber Property C Compression Set*, Method B. Type I specimens of the material shall be prepared and then exposed for 22 hours at 70°F ± 2°F (21°C ± 1°C).

4.1.17 Extreme Temperatures Operation

4.1.17.1 Requirements

A minimum of one sample barrier and applicable components of each type and size shall be subjected to an extreme temperatures operation test. The component shall be subjected to an extreme low temperature for 24 hours. At the conclusion of the temperature exposure, the barrier and components shall be evaluated for proper operation. The barrier and components shall then be visually examined and, if deemed necessary, shall be subjected to any of the appropriate tests as detailed in this standard. The same barrier and components shall then be subjected to the same sequence of testing at an extreme high temperature.

4.1.17.2 Test/Verification

The barrier and components shall be conditioned in an environmental chamber set at -40 °F (-40 °C) for a period of 24 hours. Immediately upon removal from the conditioning chamber the component shall be tested for proper function. Post testing may include any of the barrier and components testing listed in this Approval standard.

The barrier and components shall be conditioned in an environmental chamber set at 130 °F (54.4 °C) for a period of 24 hours. Immediately upon removal from the conditioning chamber, the barrier and components shall be tested for proper function. After testing, the barrier and/or components shall be visually inspected to meet the stated requirements and, if deemed, necessary, shall be subjected to any of the appropriate tests outlined in this Approval Standard.

4.1.18 Cap / Valve Locking/Supervision Ability

4.1.18.1 Requirements

All manual hand operated caps and valves, and mechanisms, shall be provided with a device such that it can be secured and/or locked and/or supervised in the component, or component assemblies intended position.

4.1.18.2 Tests/Verification

Submitted sample valves shall be examined for the provision of a secured and/or locking and/or supervision device which shall be tested during other applicable valve testing requirements for suitability.

4.1.19 Tear and Puncture Resistance Test

4.1.19.1 Requirements

The tear resistance test shall determine the tear resistance of the impermeable portion of temporary perimeter barrier (i.e. portion of the barrier that blocks the passage of water) to tearing from impact of sharp objects. For instance, impact of a tree branch or ice block may skewer the barrier, but should not result in a catastrophic failure. The impermeable membrane of the barrier shall undergo testing as described in Table 4.1.19. Post testing, the membrane shall be examined for tears. Any tear that could result in a catastrophic failure of the barrier shall constitute a failure.

4.1.19.2 Tests/Verification

The applicable ASTM Standard Test Methods described in Table 4.1.19 shall be conducted on representative samples of the barrier membrane and any other non-metallic construction material that may come into contact with debris during riverine flooding conditions. The actual material testing performed on the flood abatement equipment and associated components shall be assigned at the sole discretion of FM Approvals. The tests shall be conducted on material in five conditions: 1) As received; 2) Post Performance Test; 3) Post Aging; 4) Hot Thermal Exposure; and, 5) Cold Thermal Exposure.

Table 4.1.19: Material Testing of Non-Metallic Components

<i>Condition</i>	<i>Material</i>	<i>Test</i>	<i>ASTM Standard or Equivalent for Material Being Tested</i>
1. As Received 2. Post Performance Test 3. Post Aging 4. Hot Thermal Exposure 5. Cold Thermal Exposure	A. Sheet	Cold impact (blunt)	D1790-02
		Puncture (sharp)	D5602-98
	B. Seam	Dynamic Puncture (sharp)	D5635-04a
		Tear resistance*	D1922-03a

The tear resistance test may be used to eliminate a sharp puncture test (such as a wood board with nails) from the performance test series.

4.1.20 Biological Degradation Resistance Testing

Biological Degradation Resistance testing of elastomeric material, particularly those that contain bituminous or asphaltic compounds shall be at the sole discretion of FM Approvals based on the documentation examination of the proposed materials. Certain elastomeric materials, particularly those that contain bituminous or asphaltic compounds, are subject to material degradation due to biological attack. This type of degradation is long-term and would not necessarily affect the elastomeric barrier material during a single flood deployment, but could cause substantial degradation over extended storage times.

4.2 Temporary Perimeter Flood Barriers

The performance testing of temporary perimeter barriers has been designed to simulate actual riverine flooding conditions. The tests are divided into three categories: 1) hydrostatic loading and incidental wave, 2) wave-induced hydrodynamic loading conditions, and 3) additional hydrodynamic loading and special application. Table 4.2.1, Perimeter Flood Barrier Performance Tests, provides details pertaining to these categories.

In addition to the performance tests, applicable material tests of the components of the flood abatement equipment shall be performed as outlined in Section 4.1 of this Standard.

There are two possibilities for product Approval. Class I Approval requires the satisfactory completion of Category 1, Category 2 and Category 3 tests. Class II Approval requires the satisfactory completion of only Category 1 and Category 2 tests. Figure 4.2.1 contains a flow chart of the Approval test process. All of the tests contained in this program are events that can be anticipated during a single flood occurrence. As a result, a vendor seeking Approval must complete all of the tests in the sequence listed in Table 4.2.1 with the same product. If a vendor seeks Class I Approval then Category 3 testing must be conducted immediately following Category 1 and Category 2 testing.

No rebuilds or major repairs shall be allowed during any portion of the performance test series. The conditions represented by the performance tests are all events that are conceivable during the same flood occurrence. At the discretion of FM Approvals, some minor repairs may be allowed, for example; replacement of straps, anchors, and tie-downs. Any item swapped shall require an appropriate adjusted to the product specifications and may also result in a redo of the test where the failure occurred and any preceding test deemed appropriate. No repairs shall be allowed that can put facility personnel in harms way.

Table 4.2.1 *Perimeter Flood Barrier Performance Tests*

Test Categories		Condition (Duration)	Minor Repair Allowed* (only 1 allowed)
1. Hydrostatic and Incidental Wave Tests	Static Water	1.0 ft (0.30m) depth (22 hours)	After 22 hours of testing
		2.0 ft (0.61 m) depth (22 hours)	After 22 hours of testing
		100 percent x $h \pm 0.5$ in (13mm) (22 hours)	After 22 hours of testing, and water level lower to 80 percent h
	Incidental Wave	1 ft (0.3 m) depth, 2in (50 mm) Wave, (7 hrs)	After finish of 80 percent h , Incidental Wave test
80 percent x h , 2 in (50 mm) Wave, (7hrs)			
2. Wave-Induced Hydrodynamic Tests	Dynamic Wave	80 percent x h , 8 in (200 mm) Wave, (3 min) Perform twice	After finish 80 percent h , High Wave test
3. Additional Hydrodynamic and Special Application Tests	Current	100 percent x $h \pm 0.5$ in (13mm) 7 ft/s (2.13 m/s) (1 hr)	After 1 hour of testing, and water level lower to 80 percent h
	Over- flow	≥ 1 in (2.5 cm) overflow (1 hr)	After 1 hour of testing, and water level lower to 80 percent h
	Impact	12 in (30 cm) diameter log 500 lb (227 kg) weight at 7 ft/s (2.13 m/s)	Removal of all material
17 in (43 cm) diameter log 750 lb (340 kg) weight 7 ft/s (2.13 m/s)			

*For allowable repairs, see Section 4.2

The manufacturer specified design water depth for the structure is defined as “ h ” or 3 ft (0.9 m), whichever is lower.

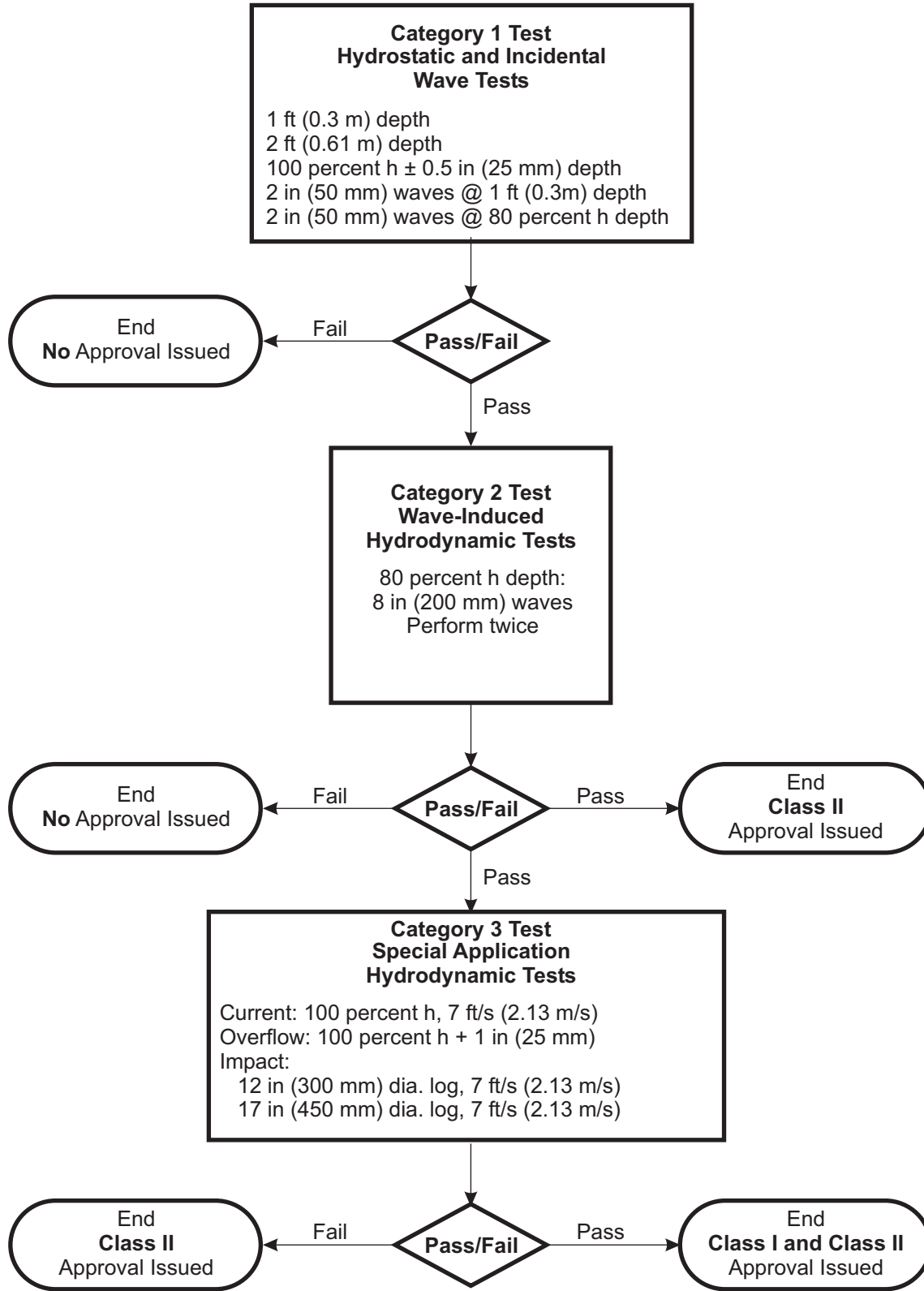
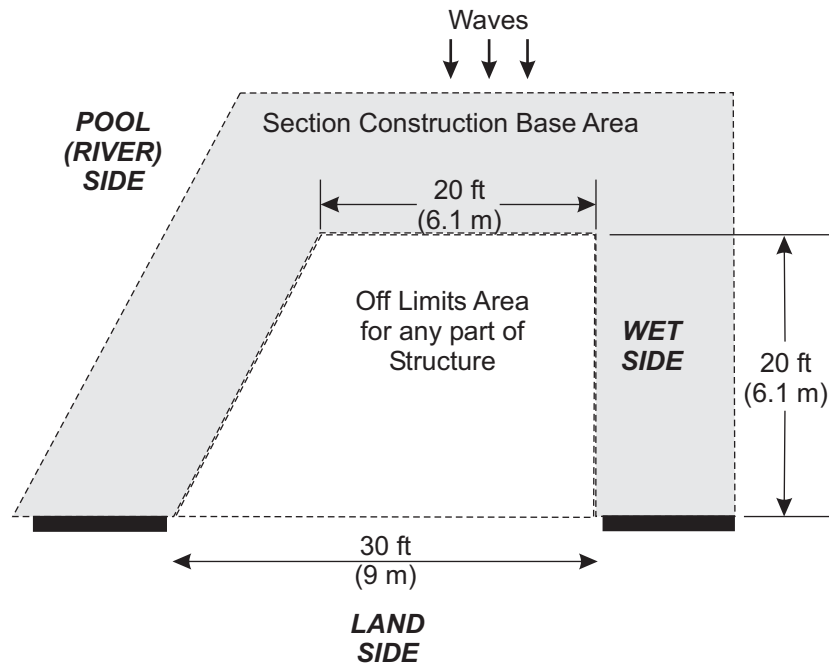

Figure 4.2.1 Perimeter Barrier Performance Testing Flow Chart

A. Barrier Layout

The temporary barriers shall be constructed to form a skewed u-shaped structure, presented as Figure 4.2.2. Each structure shall have an approximate length of 65 ft (20 m) as measured along the barrier where the seal is formed with the ground. The construction of the structure to meet the layout requirements shall be as listed in the manufacturer specified product literature. Deviations may be allowed at the sole discretion of FM Approvals if the manufacturer does not produce segments to fit this layout, or for barriers that are designed for straight runs only.



Pumping capacity needs to be sufficient for current and overflow tests.

Figure 4.2.2 Layout and Barrier Construction

B. Pass/Fail Criteria

There are three pass/fail criteria for temporary perimeter barriers; rate of leakage, deflection, and deployment.

Rate of Leakage:

The recorded rate of leakage for any test, with the exception of the hydrodynamic wave tests and the overflow test, shall not exceed 0.05 gallons per minute per foot length (0.75 liters per minute per meter length) of product where it forms a seal with the base, wall or other object. Leakage rate measurements shall be made continuously during the filling process, plus at least one additional hour, and for the final three hours of the test. Leakage rate measurements during the remainder of the test duration can be adjusted as appropriate for the test setup. The reported leakage rate shall be calculated in no greater than 15 minute intervals during any measurement period. After this time period leakage rate measurements shall be taken at an interval appropriate for the test setup.

For the hydrodynamic wave tests, no rate of leakage failure criterion is given, although the total leakage rate, including overtopping, shall be used to categorize the wave protection in accordance with Table 4.2.3 (See Section 4.2.3). No rate of leakage failure criterion is given for the overflow test. For the purposes of this protocol, rate of leakage refers to: leakage, seepage, over topping and overflow.

Product Deflection:

The maximum allowable permanent deflection for any portion of the product, measured at the completion of each test, may be no more than 6 in. (15 cm). Deflection is measured from the original location of the product along its base where it forms the seal, on the river-side of the barrier, which is exposed to simulated flood conditions. Any leakage resulting from deflection is included in the rate of leakage criterion.

Deployment:

The deployment time, in terms of personnel requirements and total person-hours must be within that listed in the vendor provided product literature. Exceeding either of these criteria shall result in a failure, or a suitable and reasonable adjustment may be made to the product literature.

4.2.1 Deployment

4.2.1.1 Deployment Validation

Manufacturers shall oversee and aid in the construction of their own product, based on the specifications listed in the product literature. The deployment time, in terms of personnel requirements and total man-hours must be within that listed in the vendor provided product literature. Exceeding either of these criteria shall result in a failure, or a suitable and reasonable adjustment may be made to the product literature.

The vendor shall arrive on-site with all supplies and materials, except fill, in a manner similar to transporting the product to a field location. Fill material may be stockpiled at a designated location at the test facility.

The deployment time is measured from the initial unloading of the product. Once the manufacturer stops the clock, any changes to the product must be approved by FM Approvals.

The deployment process shall be recorded using a video camera. Documentation and evaluation shall be made of specific deployment specification, including:

- Person-power requirements
- Deployment duration
- Foundation requirements
- Material and equipment required for practical field application and deployment only
- Ease of assembly and construction of system
- Special construction considerations
- Application limitations
- Damage during construction

4.2.1.2 Deployment Team

The deployment team shall consist of: no more than one skilled personnel, one heavy machine operator, and as many unskilled personnel as desired by the manufacturer. Skilled personnel is defined as a person with specific knowledge of the installation method for a particular barrier, this person will most likely be associated with the product manufacturer. The heavy machine operator must be approved by the testing laboratory for safety reasons. Unskilled personnel are defined as persons without specific knowledge of the installation for a particular barrier; these persons are not associated with the manufacturer. FM Approvals must approve of any unskilled persons assigned for this task.

4.2.1.3 Ground Surface

The floor of the test facility is considered an integral portion of the barrier design. FM Approval shall only be granted for use on a surface similar to that present during performance testing.

4.2.1.4 Disassembly Review

At the completion of the tests, the vendor shall disassemble the barrier and restore to a similar pre-test storage condition. Suitability for reuse shall be subjectively determined by FM Approvals. Failures for reuse could include but are not limited to tears, permanent deformation, and/or stretching. At the discretion of FM Approvals, after visual inspection additional testing shall be added if deemed necessary. The disassembly procedure shall be recorded with a video camera and evaluated in the same manner as the deployment process.

4.2.2 Filling

Filling must be at a rate of less than or equal to 1/3 ft. (10.0 cm) per hour for the first 1 ft. (0.3m) in depth, and then at a maximum rate of 3 ft. (0.91m) per hour.

4.2.3 Hydrostatic and Incidental Wave – Category 1 Testing

The initial and most basic component of the protocol is to evaluate the structural and hydraulic response of each perimeter barrier to quasi-static, hydraulic loading. There are two separate test categories; hydrostatic head test and incidental wave test.

Measurements shall be made of leakage, including seepages through the interface and the body of the perimeter barrier as well as through the bottom and side seals. Measurements in terms of average volumetric quantity per unit of time per length of seal shall be used to calculate amounts of water flowing under or through the barrier. The overall rate of leakage shall not exceed 0.05 gallons per minute per foot length (0.75 liters per minute per meter length) of product where it forms a seal with the base, wall or other object)This does not include seals within the product, similar, to that found on stop log barriers).

Measurements shall be made at any location deemed appropriate, at the discretion of FM Approvals, including along each segment of the product.

Any observable movement of the perimeter barrier shall be documented and recorded on video. The wall shall be measured for any lateral deflection in order to determine whether it is sound under increasing static loading. The maximum allowable permanent deflection for any portion of the product, measured at the completion of each test, may be no more than 6 in. (15 cm).

4.2.3.1 Hydrostatic Head Test

The Hydrostatic Head test shall consist of flooding the river-side of the basin to the desired water level. Three still water depths shall be used for testing: 1.0 ft \pm 0.5 in (0.30 m \pm 13 mm), 2.0 ft \pm 0.5 in (0.61 m \pm 13 mm), and 100 percent \times h \pm 0.5 in (13 mm), where h is the manufacturer specified design water depth for the structure or 3 ft (0.9 m), whichever is lower. At each increment, the water level shall be held at constant stage for a minimum of 22 hours. If the manufacturer specified maximum water depth for a temporary perimeter barrier is less than or equal to 2.0 ft \pm 0.5 in (0.61 m \pm 13 mm), the water depths may be changed as deemed appropriate by FM Approvals.

4.2.3.2 Incidental Wave Test

The testing protocol for the Incidental Wave tests shall consist of spectral waves generated with a JONSWAP spectrum to impinge perpendicular to the face of the barrier. Two still water depths shall be used for testing: 1.0 ft and 80 percent \times h, where h is the design water depth for the structure or 3.0 ft (0.9 m), whichever is lower. For each depth, the wave spectrum shall consist of a significant wave of height of 2 in (50 mm), measured from trough to crest, with a mean wave period of 1.03 s and shall impact the structure for 7 hrs. If the manufacturer specified maximum water depth for a temporary perimeter barrier is less than or equal to 2 ft. 6 in. (0.76 m) the water depths may be changed as deemed appropriate at the sole discretion of FM Approvals.

4.2.4 Wave-Induced Hydrodynamic Load – Category 2 Testing

The purpose of dynamic load testing is to observe the structural response of the perimeter barrier under wave-induced hydrodynamic loading conditions. The leakage observations and displacement measurements as described for Hydrostatic testing shall also be done during Wave-Induced Hydrodynamic testing. Any wave overtopping of the barrier shall be included in the volume of leakage. Hydrodynamic failure of temporary structures may include but are not limited to material failure or fatigue, fill-loss, wall sliding or overturning, and deformation.

For the hydrodynamic wave tests, no rate of leakage failure criterion is given. However, the total leakage rate, including overtopping, shall be used to categorize the wave protection in accordance with Table 4.2.2. The achieved wave protection category rating shall be documented as part of the Approval.

For the purposes of this protocol, rate of leakage refers to leakage, seepage, and overtopping.

Table 4.2.2 *Wave Protection Categories*

<i>Leakage (including overtopping)</i>		<i>Wave Protection Category</i>
>0.14 gal/min/ft	>1.73 L/min/m	Low protection against waves
>8.4 gal/hr/ft	>104.3 L/hr/m	
0.05 to 0.14 gal/min /ft	0.62 to 1.73 L/min/m	Medium protection against waves
3.0 to 8.4 gal/hr/ft	37.3 to 104.3 L/hr/m	
<0.05 gal/min /ft	<0.62 L/min/m	High protection against waves
<3.0 gal/hr/ft	<37.3 L/hr/m	

4.2.4.1 Wave-Induced Hydrodynamic Load Test

The Wave-Induced Hydrodynamic Load testing shall consist of spectral waves generated with a JONSWAP spectrum to impinge perpendicular to the face of the barrier. The still water depth shall be 80 percent $\times h$, where h is the design water depth for the structure or 3.0 ft (0.9 m), whichever is lower. The wave spectrum shall consist of a significant wave of height of 8 in (200 mm), measured from trough to crest, with mean wave period of 1.03 s and shall impact the structure for two 30 min increments. At the end of each 30 minute increment, the basin shall be stilled for up to 45 minutes to allow the waves to dissipate. If the manufacturer specified maximum water depth for a temporary perimeter barrier is less than or equal to 2.0 ft \pm 0.5 in (0.61 m \pm 13 mm), the water depths may be changed at the sole discretion of FM Approvals.

4.2.5 Additional Hydrodynamic Loads – Category 3 Testing

There are three tests conducted as part of Category 3 Testing: 1) Current testing 2) Static Overflow, and 3) Debris Impact.

Measurements shall be made of leakage, including seepages through the interface and the body of the perimeter barrier as well as through the bottom and side seals during the current and debris impact test. Leakage shall not be measured during the overflow test; however, any floating of the barrier shall result in a test failure. The maximum allowable deflection for any portion of the product, measured at the end of each test, may be no more than 6 in. (15 cm).

4.2.5.1 Current Test

Testing shall be conducted at a water elevation of 100 percent $h \pm$ 0.5 in (13 mm), where h is design water depth for the structure or 3 ft (0.9 m), whichever is lower. Current shall be applied to the barrier parallel to the face of the barrier. The water velocity shall be slowly increased to 7.0 ft/s (2.1 m/s) [\sim 5.0 mph (8.0 km/h)] and then maintained steady for 1 hour. Permanent deflection, assessed at the end of the test, of greater than 6 in. (15 cm) at any portion of the barrier shall be considered a failure. If the length of the tested barrier varies from that specified in this protocol, then the allowable deflection may be adjusted at the discretion of the FM Approvals. A minimum channel width of 6 in. (15 cm) should be created for the water flow.

Measurement of water velocity shall be made at 50 percent of the water depth approximately 6 in. (15 cm) from the front face of the barrier and the horizontal midpoint of the section of barrier exposed to the current, or 1/2 the distance from the barrier to the wall, whichever is less.

4.2.5.2 Overflow Test

Overflow shall be caused to occur at a riverside water level equal to 100 percent of structure height plus one inch [barrier height must be below 3 ft (0.9 m)]. Water level on the river-side of the barrier shall be slowly raised until the depth of flow over the structure is at least 1 in. (2.5 cm) greater than structure height). The water level should be maintained a constant as practical with little depth on the dry side. The overflow test shall proceed for one hour after steady state conditions are achieved or until failure occurs. Flotation of the barrier shall be considered an immediate failure.

4.2.5.3 Debris Impact Test

The purpose of the debris impact test is to evaluate the structural response of the barrier to a simulated debris load. Initially, the riverside of the barrier shall be filled at a water level equal to $66\frac{2}{3}$ percent \times $h \pm 0.5$ in (13 mm). A log shall then be pulled into the barrier using a system to provide an impact with a velocity of 7.0 ft/s (2.1 m/s) [\sim 5.0 mph (8.0 km/h)], see Figure 4.2.3. The pulling action shall be shut-off immediately before impact. The trajectory angle between the log and the barrier shall be approximately 70 degrees. Two different floating logs shall be used; 12 in. (30 cm) and 17 in. (43 cm) diameter logs, 500 lb (225 kg) and 750 lb (340 kg) in weight respectively. The smaller log shall be used first, followed by the bigger one. The impact location from each log shall be at the sole discretion of FM Approvals. Immediately following each log impact, a hydrostatic load test shall be conducted at the original water level for that test, for a minimum of 22 hours.

The movement and damage to the barrier, if any, from the smaller log impact shall be observed before continuing to the larger log impact. If the barrier is leaking profusely or has experienced more than 6 in. (15 cm) permanent movement after the smaller impact log test, the bigger impact log test may not be performed. Laboratory and FM Approval personnel shall determine if it is safe to continue with the next impact log tests.

The log shall be southern pine or similar density and conditioned by submerging in water for a minimum of 2 weeks prior to the test. The cut edges of the logs are required to be perpendicular saw-cut with no edge rounding.

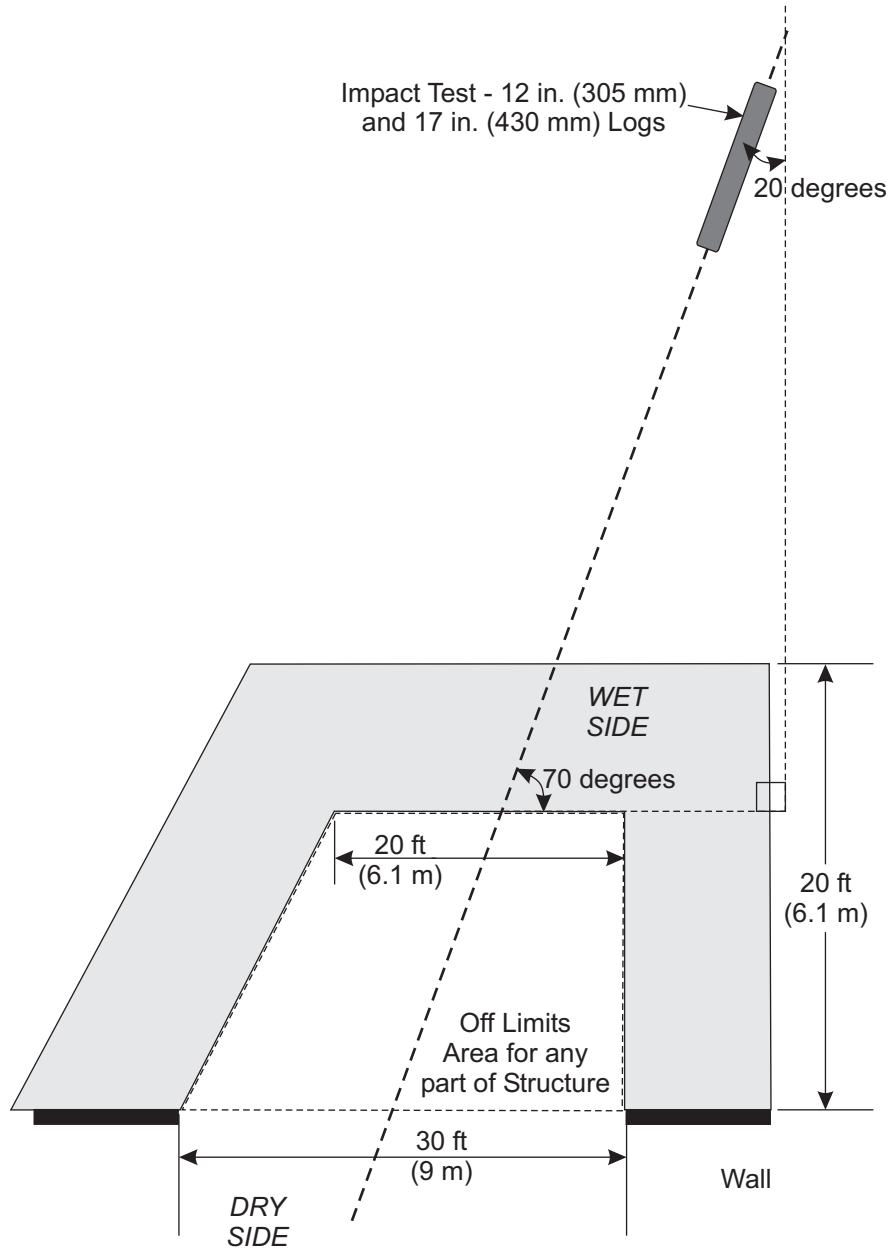

Figure 4.2.3 Debris Impact Test Layout

4.3 Opening Barriers

The performance testing of opening barriers has been designed to simulate quasi-static riverine flooding conditions, i.e. slow rising and receding flood waters with minimal wave exposure. This condition assumes that the primary exposure is due to hydrostatic loading and blunt debris impact. The performance tests are divided into two categories: 1) hydrostatic loading, and 2) dynamic impact loading. In addition, re-use of the barrier shall be addressed by requiring the barrier to be removed and re-deployed at the conclusion of each test. As all of the tests contained in this program are events that can be anticipated during a single flood occurrence, a vendor seeking FM Approval must complete all of the tests in sequence, with the same test sample.

In addition to the performance tests, material tests as outlined in Section 4.1 of the components of the flood abatement equipment shall be performed. Table 4.3.1 outlines the opening flood barrier performance tests.

Table 4.3.1 *Opening Flood Barrier Performance Tests*

<i>Test</i>	<i>Condition</i>	<i>Duration</i>	<i>Notes</i>
Hydrostatic Load	100 percent x $h \pm 0.25$ in (0.6 cm)	22 hours	Tests conducted sequentially with the same sample
Dynamic Impact Load	1) 600 J impact at weak point on panel	1 hour	Hydrostatic load test conducted 3 times
	2) Hydrostatic load test at 100 percent x $h \pm 0.25$ in (0.6 cm)		
	1) 600 J impact at weak point of frame	1 hour	Impact test conducted once per location
	2) Hydrostatic load test at 100 percent x $h \pm 0.25$ in (0.6 cm)		
Additional locations on panel or frame	N/A	Remove and re-install product for each repeat	
			No Major Repairs Allowed

A. Barrier Layout

The building opening barrier shall be installed to meet the specifications listed in the manufacturer’s product literature. At minimum, all testing shall be conducted on the maximum opening barrier size. If there are substantial changes between barriers made to protect either larger or smaller sized openings, additional testing may be required. Determination of substantial changes is solely at the discretion of FM Approvals personnel.

The test enclosure shall be of sufficient width to accommodate the opening barrier, including any associated installation materials, plus a minimum of 3 ft. (0.9 m) on each side of the barrier. The enclosure length shall be at least 3 ft. (0.9 m) long, or sufficient to allow the barrier to be opened and closed in the intended manner. The depth of the enclosure shall be at least 3.5 ft (1.0 m) deep. All walls and joints shall be appropriately designed and sealed to prevent the ingress or egress of water.

The test facility shall contain:

- Equipment to continuously measure leakage rate, to a tolerance of ± 5 percent of the maximum allowable leakage rate, as defined in Section 4.3 B.
- Equipment to measure static water levels
- Instrumentation to measure the water temperature.

B. Pass/Fail Criteria

There are three pass/fail criteria for opening barriers; rate of leakage, deployment, and permanent deflection.

Rate of Leakage:

The recorded rate of leakage for any test shall not exceed 0.08 gallons per hour per linear foot (1 L/h/m) of protected opening over any 15-minute period. Linear length of protected opening is determined as the opening width. For the purposes of this protocol, rate of leakage refers to both leakage through the barrier and seepage around the barrier. Exceeding the maximum rate of leakage during any test shall result in a failure.

Deployment and Re-Deployment:

The deployment time, in terms of personnel requirements and total person-hours must be within that listed in the vendor provided product literature. Exceeding either of these criteria shall result in a failure. Deployment does not include the initial installation of the barrier.

At the completion of each test, the barrier shall be removed and evaluated for wear or damage. The vendor shall then re-deployed the barrier for the start of the next test. The effort required by personnel for re-deployment must be consistent with the initial deployment of the barrier. Exceeding this criterion shall result in a failure.

Permanent Deflection:

The maximum amount of permanent deflection allowed after the Dynamic Load Impact test outlined in Section 4.3.3 shall be less than a quantity of $L/120$ but not greater than 1 inch (25 mm), where L is the linear span of the opening measured in inches (millimeters). Permanent dents at the point of impact shall be allowed as long as they do not impair the functionality of the barrier as determined by FM Approvals.

4.3.1 Initial Deployment

Vendors shall construct and install their own product, based on the specifications listed in the product literature. The deployment time, in terms of personnel requirements and total person-hours, must be within that listed in the vendor provided product literature.

The installation process shall be recorded using a video camera. Documentation and evaluation shall be made of specific installation specifications, including:

- Person-power requirements
- Installation duration
- Foundation requirements
- Material and equipment required
- Ease of construction
- Special construction considerations
- Application limitations
- Damage during construction

4.3.1.1 Rebuilds and Repairs

Before the start of each test, the opening barrier shall be deployed in the manner indicated in the vendor supplied product literature. At the completion of each test, the barrier shall be removed and evaluated for wear or damage. The vendor shall then re-deploy the barrier for the start of the next test. The removal and re-deployment procedure shall be recorded with a video camera and evaluated in the same manner as the initial installation process.

No rebuilds or major repairs shall be allowed during any portion of the performance test series. However, at the discretion of FM Approvals, some minor repairs may be allowed. Any item swapped shall require an appropriate adjustment to the product specifications and may also result in a redo of the test where the failure occurred and any preceding test deemed appropriate. No repairs shall be allowed that can put facility personnel in harms way.

4.3.2 Hydrostatic Load Test

The initial and most basic component of the protocol is to evaluate the structural and hydraulic response of an opening barrier to quasi-static, hydraulic loading. Continuous measurements shall be made of leakage, including; seepages through the interface and the body of the perimeter barrier and through the bottom and side seals. Any observable movement of the barrier shall be documented and recorded on video.

The Hydrostatic Head test shall consist of flooding the wet side of the test apparatus to 100 percent $\times h \pm 0.25$ in (0.6 cm), where h is the vendor specified design water depth for the structure or 3.0 ft (0.9 m), whichever is lower. The water level shall be held at constant height for a minimum of 22 hours. Rate of leakage measurements shall be conducted as described in Section 4.3.B, Pass/Fail Section.

The recorded rate of leakage for any test shall not exceed 0.08 gallons per hour per linear foot (1 L/h/m) of protected opening over any 15-minute period. Linear length of protected opening is the sum of the opening width and two times the vendor designated water depth or 3 ft (0.9 m), whichever is lower. For the purposes of this protocol, rate of leakage refers to both leakage through the barrier and seepage around the barrier. Exceeding the maximum rate of leakage during any test shall result in a failure.

At the completion the test, the barrier shall be removed and evaluated for wear or damage. The vendor shall then re-deploy the barrier for the start of the next test as described in Section 4.3.1. The removal and re-deployment procedure shall be recorded with a video camera and evaluated in the same manner as the initial installation process. At the completion of re-deployment, the Dynamic Impact Load test shall be conducted per the requirements of Section 4.3.3.

4.3.3 Dynamic Impact Load Test

The purpose of the dynamic impact test is to evaluate the structural response of the barrier to a simulated debris impact. The barrier shall be subject to an impact load of 600 J created by a rigid falling object. Leakage observations and displacement measurements as described in Section 4.3.2, Hydrostatic Load testing, shall also be done during dynamic impact load testing.

The Dynamic Impact Load test shall be conducted at a minimum of two locations on the barrier, without any water present in the test enclosure. The first impact location shall be the predetermined weak point of the barrier panel (e.g. the horizontal center point of the barrier at 80 percent $\times h$, where h is the vendor specified design water depth for the structure or 3.0 ft, whichever is lower). The second location shall be as close to the barrier perimeter as possible, at roughly the same height as the first impact. This location is intended to evaluate the barrier connection to the supporting structure. Additional impact locations on the barrier panel or frame may be included as deemed necessary by FM Approvals personnel (e.g. hinges, plastic parts, etc.).

To accomplish the impact, the object falls under gravitational acceleration through a circular trajectory to impact the barrier in the vertical position. The impact to the barrier shall be such that the leading edge of the impacting object hits the predetermined location on the barrier. Figure 4.3.3 contains a suggested layout for this test. The face of the impact object shall be a piece of saw-cut log, having no edge rounding, with a diameter of 12 in (30.5 cm) and a density similar to wet southern pine [30 lb/ft³ (48 kg/m³)]. One end of the log shall have a straight perpendicular cut and the other shall be cut at an angle of 15 degrees off-center. The straight cut end of the log shall be attached to a steel block so that the total object has mass of 110 lbs (50 kg) thus generating an impact of 600 J. A similar impact object can be substituted at the discretion of FM Approvals as long as the trajectory of impact and impact energy criteria are met.

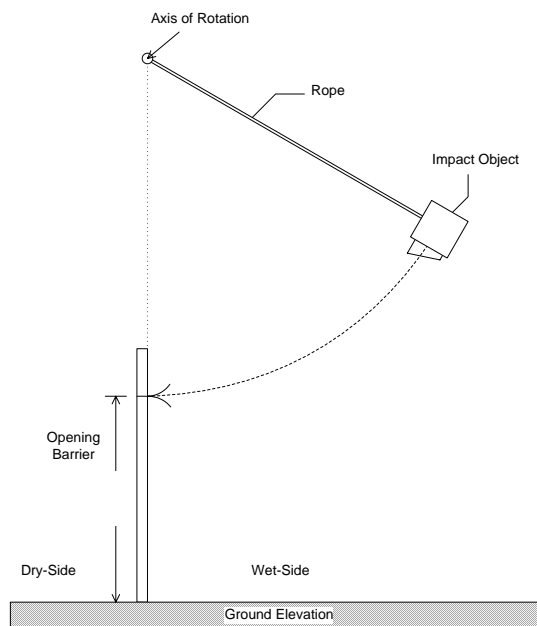

Figure 4.3.3 Impact Test Layout

The impact force (E), calculated as potential energy, is determined by the length of trajectory and weight of the impacting object, see Equation 1:

$$E = mgh$$

where, m is the mass of the impacting object (110 lb or 50 kg), g is gravitational acceleration (32.2 ft/s² or 9.81 m/s²), and h (ft or m) is the height through which the impacting object falls.

Immediately following each impact, a hydrostatic load test shall be conducted with a water level equal to 100 percent $\times h \pm 0.25$ in (0.6 cm), for one hour. The leakage rate measurements and displacement observations as described in Section 4.3.2, Hydrostatic Load testing, shall also be done during this period. The barrier shall then be removed and re-installed in the test apparatus for additional impacts or re-deployment verification.

4.4 Backflow Preventers (Grey and Black Water)

This section reserved for future use.

4.5 Sump Pumps

This section reserved for future use.

4.6 Other Flood Abatement Equipment

This section reserved for future use.

4.7 Additional Tests

Additional tests may be required, depending on design features, results of any tests, material application, or to verify the integrity and reliability of the flood abatement equipment barriers, at the discretion of FM Approvals.

Unexplainable failures shall not be permitted. A re-test shall only be acceptable at the discretion of FM Approvals and with adequate technical justification of the conditions and reasons for failure.

5. OPERATIONS REQUIREMENTS

A quality control program is required to assure that subsequent production of flood abatement equipment systems produced by the manufacturer at an authorized location shall present the same quality and reliability as the specific flood abatement equipment system examined. Design quality, conformance to design, and performance are the areas of primary concern. Design quality is determined during the Approval examination and tests, and is covered in the Approval Report. Conformance to design is verified by control of quality and is covered in the Facilities and Procedures Audit (F&PA). Quality of performance is determined by field performances and by periodic re-examination and testing.

5.1 Demonstrated Quality Control Program

5.1.1 Quality Assurance Program

The manufacturer shall demonstrate a quality assurance program which specifies controls for at least the following areas:

- Existence of corporate quality assurance guidelines;
- Incoming quality assurance, including testing;
- In-process quality assurance, including testing; (if applicable)
- Final inspection and tests;
- Equipment calibration;
- Drawing and change control;
- Product labeling;
- Packaging and shipping;
- Handling and disposition of non-conformance materials.

5.1.2 Documentation/Manual

There shall be an authoritative collection of quality procedures and policies. Such documentation shall provide an accurate description of the quality management system while serving as a permanent reference for implementation and maintenance of that system. The system should require that sufficient records are maintained to demonstrate achievement of the required quality and verify operation of the quality system.

Reference: FM Approvals “*Quality Assurance Guidelines for Manufacturer’s of FM Approved and Specification Tested Products*” dated October 2003.

5.1.3 Records

To assure adequate traceability of materials and products, the manufacturer shall maintain a record of all quality assurance tests performed and shall maintain this record for a minimum period of two years from the date of manufacture.

5.1.4 Drawing and Change Control

The manufacturer shall establish a system of product configuration control that shall allow no unauthorized changes to the product. Changes to critical documents, identified in the Approval Report, must be reported to, and authorized by, FM Approvals prior to implementation for production.

The manufacturer shall assign an appropriate person or group to be responsible for reporting proposed changes to FM Approved or Listed products to FM Approvals before implementation. The manufacturer shall notify FM Approvals of changes in the product or of persons responsible for keeping FM Approvals advised by means of FM Approvals Form 797, Approved Product Revision Report or Address/Contact Change Notice. Records of all revisions to all Approved products shall be maintained.

5.2 Facilities and Procedures Audit (F&PA)

5.2.1 An audit of the manufacturing facility is part of the Approval investigation to verify implementation of the quality assurance program. Its purpose is to determine that the manufacturer's equipment, procedures, and quality program are maintained to insure a uniform product consistent with that which was tested and FM Approved.

5.2.2 These audits shall be conducted annually by FM Approvals or its representatives or more frequently dependent on jurisdictional requirements.

5.2.3 FM Approved products or services shall be produced or provided at, or from, the location(s) audited by FM Approvals and as specified in the Approval Report. Manufacture of products bearing the FM Approvals Certification Mark is not permitted at any other location without prior written authorization by FM Approvals.

5.3 Installation Inspections

Field installation inspections may be conducted to review an installation. The inspections are conducted to assess ease of application, and conformance to written specifications. When more than one application technique is used, one or all may be inspected at the sole discretion of FM Approvals.

5.4 Manufacturer's Responsibilities

- 5.4.1 The manufacturer shall notify FM Approvals of changes in product construction, design, components, raw materials, physical characteristics, coatings, component formulation or quality assurance procedures prior to implementation of such changes.
- 5.4.2 Where all or part of the quality control has been subcontracted, the manufacturer shall, at a minimum, conduct sufficient oversight audits to verify the continued application of the required controls.
- 5.4.3 The manufacturer shall provide complete instructions for the recharge and usage of systems. The instructions shall provide specific quality assurance procedures on the usage of calibrated equipment, such as scales, pressure gauges, and other necessary critical equipment, in the recharging a system.
- 5.4.4 The manufacturer, or assigned representative shall perform a documented system acceptance check and operational test in accordance with the manufacturers "Design, Installation, Operations and Maintenance" manual. A copy of the results should be left on site and with the owner of the flood abatement equipment system, at a minimum.

5.5 Manufacturing and Production Tests

5.5.1 Test Requirement No. 1 - *Equipment Seat Leakage*

The manufacturer shall test 100 percent of all caps, fill ports, control and relief valves for leakage when subjected to a hydrostatic test pressure of 100 percent of the maximum system operating pressure. The pressure shall be held for a minimum of 15 seconds with no evidence of leakage or distortion.

5.5.2 Test Requirement No. 2 - *Equipment Hydrostatic Strength*

The manufacturer shall test 100 percent of water filled barrier equipment for hydrostatic strength to 100 percent of the maximum system operating pressure. The pressure shall be held for a minimum of 15 seconds with no evidence of body leakage or damage.

APPENDIX A: Susceptibility To Leakage Test

A.1 Introduction

The FM Approvals Susceptibility to Leakage Test Procedures are designed to assess the potential for water migration when the barrier is fabricated with a typical lap seam.

A.2 Test Apparatus

- A.2.1 The test apparatus (see Figure A-1) consists of top and bottom sections which are bolted together with the specimen being evaluated placed as a diaphragm between the sections. The top section consists of a 9-1/4 in. (203 mm) diameter cap which has two 1/2 in. (13 mm) diameter threaded inlet holes. This top cap is cemented to a 5-3/4 in. (146 mm) length of 7-3/4 in. (197 mm) diameter clear acrylic pipe which is cemented to an 11-3/4 in. (295 mm) diameter pipe flange. The bottom section consists of a 9-1/4 in. (235 mm) cap which has two 1/2 in. (13 mm) diameter threaded inlet holes. The bottom cap is cemented to a 5-7/8 in. (149 mm) length of 7-3/4 (197 mm) diameter clear acrylic pipe which is cemented to an 11-5/8 in. (295 mm) diameter pipe flange.
- A.2.2 Both top and bottom sections are bolted together at the flanges with the cover being evaluated between them. The top and bottom caps are fabricated to allow both a standing head of water above and additional air pressure both above and below. Each section is fabricated with two 1/2 in. (13 mm) diameter pipe outlets to allow connection of an air pressure inlet and pressure gauge.

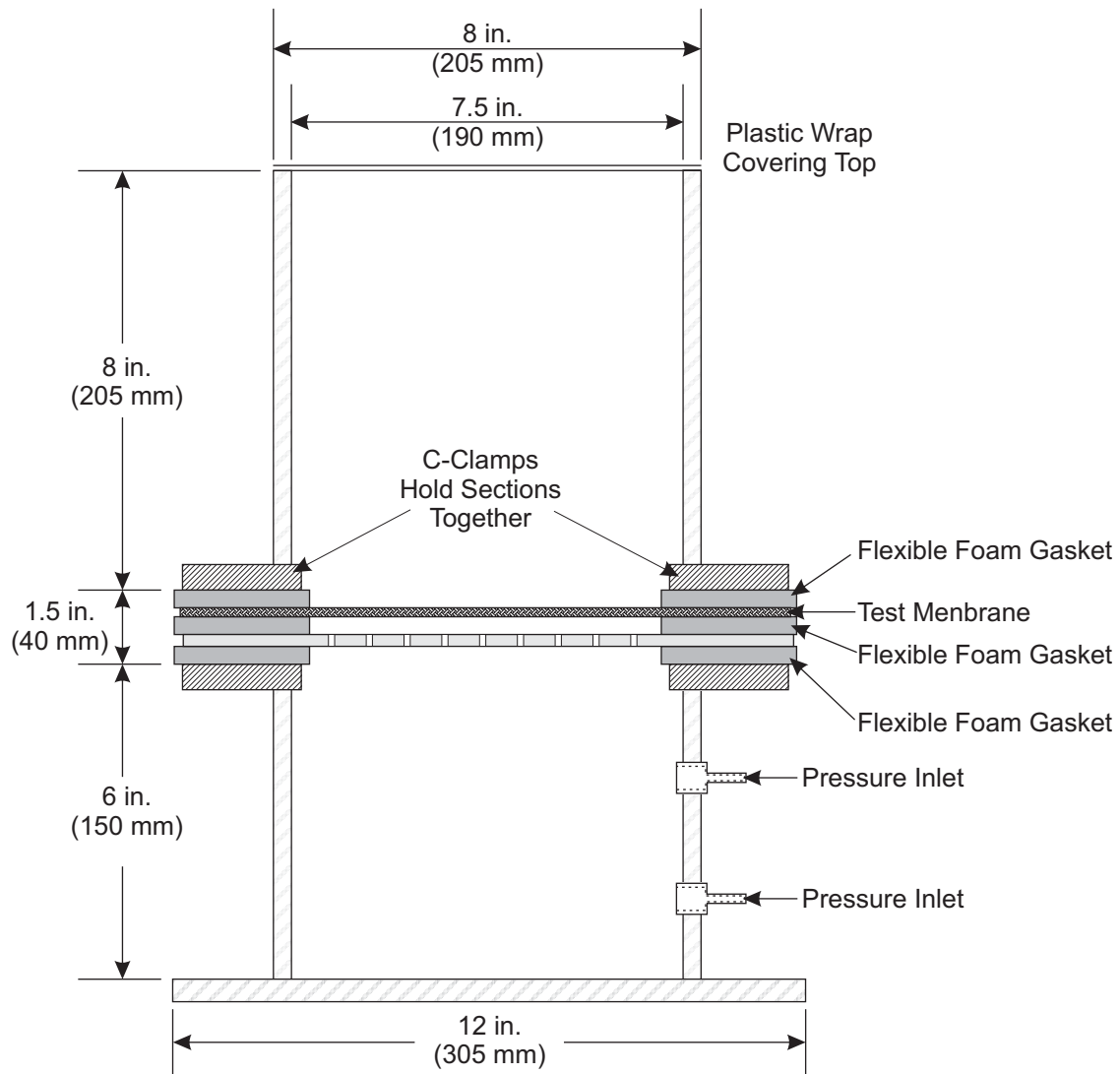

Figure A-1. Leakage Test Apparatus

APPENDIX B: Impact Resistance Test Procedure for Components for Flood Abatement Barrier Securement

B.1 Introduction

B.1.1 The FM Approvals Impact Resistance Test Procedure is designed to assess the potential for damage to components when utilized for securing flood abatement equipment barriers to the ground surface. It was developed to determine the potential for crazing and fracture when components are stressed and/or subjected to impact forces that may occur during the construction periods and life span of the barrier.

B.2 Description of Test Apparatus

B.2.1 The test apparatus consists of a section of 4 in. (102 mm) ID steel tube supported above the sample. A steel impactor weighing 10.0 pounds (4.7 kg) is dropped from 5.0 ft (1.5 m) onto the sample. The steel tube is adjustable so that a distance of 5 ft (1.5 m) from the top of the sample to the bottom of the impactor may be maintained.

B.3 Test Procedure

B.3.1 Components are placed in a refrigeration cabinet and subjected to a temperature of 10°F (-12°C) for a 24 hour period. A 12 in. × 12 in. (305 mm × 305 mm) sample is prepared with the component(s), removed from the cabinet, immediately applied to secure the selected barrier in accordance with the manufacturer's specifications. When applicable, the securement component shall be driven or installed to the maximum torque or force as specified by the manufacturer. The sample is then inspected for damage.

B.3.2 The completed samples are placed in a refrigeration cabinet and conditioned for 24 hours at 10°F (-12°C). The conditioned samples are then removed from the cabinet and placed on the supports of the test apparatus. A steel impactor is dropped from a height of 5 ft (1.5 m) onto the sample. A minimum of three drops of the impactor is required. The sample is then removed and inspected for damage.

B.4 Evaluation of Results

B.4.1 The component(s) shall not fracture or show any signs of crazing.

APPENDIX C: Corrosion Test Procedure for Flood Abatement Barrier Securement Components

C.1 Introduction

C.1.1 The FM Approvals Corrosion Test Procedure is designed to assess the potential damage to flood abatement barrier securement components used for attachment of barrier to a surface. There is no single test procedure which approximates all climatic conditions experienced by flood abatement barrier components. However, tests are available which provide an indication of potential resistance to corrosion.

C.2 Test Procedure

C.2.1 Tests are conducted in accordance with the DIN 50018 Standard Test (2.0 liters) on samples prepared to simulate the manufacturers describe securement method. Each sample is subjected to 15 cycles of exposure. All securement components shall also meet these requirements.

C.3 Evaluation of Results

C.3.1 The flood abatement barrier securement components shall not show more than 15 percent of the surface area corroded.

Coatings covering these components shall not blister, peel or crack.

APPENDIX D: Susceptibility to Hail Damage Test Procedure

D.1 Introduction

- D.1.1 The FM Approvals Simulated Hail Damage Test Procedures are designed to assess the potential for puncture damage and coating degradation to flood abatement barriers from hail storms.
- D.1.2 Due to the variable severity of potential damage resulting from hail storms in different geographic areas, two separate hail damage tests are used. The tests yield ratings identified as Class 1-SH (Severe Hail Damage Resistant) and Class 1-MH (Moderate Hail Damage Resistant), which correspond with the areas identified in FM Global Property Loss Prevention Data Sheet 1-47S.1.

D.2 Description of Test Apparatus

- D.2.1 Class 1-SH - The test apparatus consists of a section of plastic tube 2 in. (51 mm) inside diameter supported above the sample. A steel ball 1 3/4 in. (45 mm) in diameter weighing 0.79 lb (359 g) is dropped from a height of 17 ft 9 1/2 in. (5.4 m) onto the sample. This procedure is repeated ten times on various sections of the sample. This procedure generates an impact energy of approximately 14 ft-lb (19 J) over the impact area of a 1 3/4 in. (45 mm) diameter ball.
- D.2.2 Class 1-MH - The test apparatus consists of a steel tube 2 1/4 in. (57 mm) inside diameter supported vertically above the sample by a tripod. Holes are drilled in the steel tube to allow the release mechanism to be adjusted for the proper drop height. A steel ball 2 in. (51 mm) in diameter weighing 1.625 lb (737 g) is dropped from a height of 5 ft (1.5 m) through the tube onto the sample. This procedure is repeated ten times on various sections of the sample. This procedure generates an energy of approximately 8 ft-lb (11 J) over the impact area of a 2 in. (51 mm) diameter ball.

D.3 Test Procedure

- D.3.1 A 2 ft × 4 ft (0.6 m × 1.2 m) barrier sample is placed on a support. The panel support is a 2 ft × 4 ft (0.6 × 1.2 m), outside dimensions, box open on the top and bottom and comprised of 1- 1/2 in. (38 mm) wide × 3-1/2 in. (89 mm) high wooden panels which are nailed together at its corners. The sample is secured to the box with self-drilling fasteners spaced 12 in. (305 mm) on center along its perimeter. The 1- 3/4 in. (45 mm) diameter steel ball is dropped onto the sample from a height of 17 ft 9- 1/2 in. (5.4 m) for a Class 1-SH rating, or the 2 in. (51 mm) diameter ball is dropped onto the sample from a height of 5 ft (1.5 m) for a Class 1-MH rating. A minimum of ten drops of the impactor is required. The barrier samples are then removed and inspected for damage. A 2 ft × 4 ft (0.6 m × 1.2 m) barrier sample is placed on a support. The panel support is a 2 ft × 4 ft (0.6 × 1.2 m), outside dimensions, box open on the top and bottom and comprised of 1-1/2 in. (38 mm) wide × 3-1/2 in. (89 mm) high wooden panels which are nailed together at its corners. The sample is secured to the box with self-drilling fasteners spaced 12 in. (305 mm) on center along its perimeter. The 1- 3/4 in. (45 mm) diameter steel ball is dropped onto the sample from a height of 17 ft 9-1/2 in. (5.4 m) for a Class 1-SH rating, or the 2 in. (51 mm) diameter ball is dropped onto the sample from a height of 5 ft (1.5 m) for a Class 1-MH rating. A minimum of ten drops of the impactor is required. The barrier samples are then removed and inspected for damage.

- D.3.2 A 12 in. × 24 in. (305 mm × 610 mm) barrier sample is prepared from the 2 ft × 4 ft (0.6 m × 1.2 m) barrier sample and conditioned (weathered) for 1008 hours in a fluorescent ultraviolet condensation-type weathering apparatus using the ASTM G154 Standard Practice for Operating Fluorescent Light Apparatus for UV Exposure of Nonmetallic Materials. The cycle time shall be 8 hours UV at 140°F ±5°F (60°C ±3°C) and 4 hours condensation at 122°F ±5°F (50°C ±3°C). The UV source shall be UV-B lamps with a peak emission at 313 nm. After weathering, the impact test procedure outlined in Section D-3.1 is repeated. The sample is then removed and inspected for damage. Barrier samples that have a non-metal exterior surface shall also show no signs of water penetration through the sample when tested by the FM Approvals Water Penetration Test Procedures (see Appendix F).

D.4 Evaluation of Results

A flood barrier shall not be punctured and the coating shall not show any signs of chipping, peeling, cracking, or crazing when examined under a 10X magnification. A barrier sample shall not show any signs of chipping, peeling, or puncture when examined under a 10X magnification and shall not allow water penetration through the sample when tested in accordance with the FM Approvals Water Penetration Test Procedures.

APPENDIX E: Units of Measurement

FLOW:	gal/min - "gallon per minute"; (L/min - "liters per minute") L/min = gal/min x 3.7854
FORCE:	lbf - "pounds-force"; (N - "newtons") N = lb x 4.4482
LENGTH:	in. - "in."; (mm - "millimeters") mm = in. x 25.4 ft - "feet"; (m - "meters") m = ft x 0.3048
MASS:	Lb - "pounds"; (kg - "kilograms") kg = lb x 0.454
PRESSURE:	psi - "pounds per square inch"; (bar - "bars") bar = psi x 0.06895 psf - "pounds per square foot"; (kPa - "kilopascals") bar = psf x 0.00479
TEMPERATURE:	°F - "degrees Fahrenheit"; (°C - "degrees Celsius") °C = (°F - 32) x 0.556
TORQUE/MOMENT:	lbf·ft - "pound-force foot"; (N·m - "newton meters") N·m = lbf·ft x 1.356
VACUUM:	inHg - "in. of mercury"; psi - "pounds per square inch"; (kPa - "kilopascals") psi = inHg x 0.4912 kPa = inHg x 3.3864
VOLUME:	gal - "gallons"; (L - "liters") L = gal x 3.7854
VOLUME PER UNIT AREA:	gal/min/ft ² - "gallons per minute per square foot" (mm/min - "millimeters per minute") mm/min = gal/min/ft ² x 40.75

APPENDIX F: Tolerances

Unless otherwise stated, the following tolerances shall apply:

Angle:	$\pm 2^\circ$
Frequency (Hz):	± 5 percent of value
Length:	± 5 percent of value
Volume:	± 5 percent of value
Rotation:	± 1 RPM
Pressure:	± 5 percent of value
Temperature:	± 5 percent of value
Time:	+ 5/- 0 seconds + 0.1/- 0 minutes + 0.1/- 0 hours + 0.25/- 0 days

Unless stated otherwise, all tests shall be carried out at a room (ambient) temperature of $68^\circ\text{F} \pm 18^\circ\text{F}$ ($20^\circ\text{C} \pm 10^\circ\text{C}$).

APPENDIX G: FM Approvals Certification Marks

FM Approvals certifications marks are to be used only in conjunction with products or services that have been Approved by FM Approvals and in adherence with usage guidelines.



FM APPROVED MARK:

Authorized by FM Approvals as a certification mark for any product that has been FM Approved. There is no minimum size requirement for the mark, but it must be large enough to be readily identifiable. The mark should be produced in black on a light background, or in reverse on a dark background.



CAST-ON FM APPROVALS MARKS:

Where reproduction of the FM Approved mark described above is impossible because of production restrictions, use these modified versions of the FM Approved mark. There is no minimum size requirement for the mark, but it must be large enough to be readily identifiable.



FM APPROVED MARK WITH "C" ONLY:

Authorized by FM Approvals as a certification mark for any product that has been evaluated by FM Approvals in accordance with Canadian codes and standards. There is no minimum size requirement for the mark, but it must be large enough to be readily identifiable. The mark should be produced in black on a light background, or in reverse on a dark background.



FM APPROVED MARK WITH "C" AND "US":

Authorized by FM Approvals as a certification mark for any product that has been evaluated by FM Approvals in accordance with US and Canadian codes and standards. There is no minimum size requirement for the mark, but it must be large enough to be readily identifiable. The mark should be produced in black on a light background, or in reverse on a dark background.

USAGE GUIDELINES

All FM Approvals certification marks are the sole property of FM Approvals LLC (“FM Approvals”) and are registered or the subject of applications for registration in the United States and many other countries. They are for use only according to these guidelines.

FM Approvals certification marks may be used only on FM Approved products and related product packaging, in advertising material, catalogs and news releases. Use of FM Approvals certification marks on such material is not a substitute for use of the complete FM Approvals certification mark on FM Approved products and/or product packaging.

No FM Approvals certification mark or aspect thereof may be incorporated as part of a business name, Internet domain name, or brand name/trademark for products/product lines. This includes both design aspects (the FM Approvals “diamond,” etc.) and word aspects (“FM,” “Approved,” etc.). The use of any FM Approvals certification mark as a trademark is strictly prohibited.

The Approval Standard number or class number may not be incorporated as part of a business name, Internet domain name, or brand name/trademark for products/product lines. For example, a company may not say “ABC Company’s 4100 Fire Door is FM Approved”; the proper terminology is, “ABC Company’s Fire Door is FM Approved per Approval Standard 4100.”

FM Approvals certification marks, except for the FM Approvals Quality System Registration mark, may not be used on business stationery/cards/signage because this could mischaracterize the relationship with FM Approvals. Additionally, these items should not reference any FM Approvals certification mark.

Products or services may not be marketed under any mark or name similar to “FM Global,” “FM Approvals” or any of the FM Approvals certification marks. Further, products or services may not be marketed to imply a relationship beyond the scope of any Approval made by FM Approvals.

When an FM Approvals certification mark is used in advertising material or on product packaging, all material must reflect the specific circumstances under which the product was FM Approved. The material must clearly differentiate between products that are FM Approved and those that are not, and may not, in any way, imply a more substantial relationship with FM Approvals.

A company may not reference the intent to submit a product for Approval or the expectation that a company will have a certain product FM Approved in the future. For example, a company may not state, “Approval by FM Approvals pending” or “Approval by FM Approvals applied for.”

FM Approvals certification marks should not be preceded or followed by a qualifier that indicates a degree of certification or acceptability. For example, “exceeds,” “first” or “only” may not be used to qualify any FM Approvals certification mark.

Only original artwork issued by FM Approvals should be used. The FM Approvals certification marks should not be altered in any way other than to resize the artwork proportionately. Unacceptable uses of the marks include, but are not limited to, adding/deleting wording or artwork, reducing the artwork to an illegible size, animation or distortion.

The text of the FM Approvals certification marks may not be translated into any language other than English.

FM Approvals certification marks must appear in a size and location that is readily identifiable, but less prominent than the name of the owner of the certification or the manufacturer/seller/distributor of the certified products.

APPENDIX H: USACE Coastal and Hydraulics Laboratory Test Facility Description

Unless the manufacturer provides a suitable alternate test facility, FM Approvals has determined that performance testing shall be conducted at a modified wave basin at the ERDC Coastal and Hydraulics Laboratory, located in Vicksburg, Mississippi. Modifications include construction of wing walls to which the flood fighting structures shall be attached, installation of an 8 ft. (2.44 m) diameter sump with pumps and flow meters for measuring leakage rates and re-circulating water during overtopping tests, and development of a cable towing system for debris impact.

The research facility consists of a 100 ft. (30.48 m) wide by 150 ft. (45.72 m) long basin with 4 ft. (1.22 m) high walls. One end of the facility contains three electric-driven piston-type wave generators, each driving a 25 ft. (7.62 m) wide wave paddle. The three wave generators are synchronized so that they all run together as a 75 ft. (22.86 m) wide generator. Guide vanes contain the wave train for the first 50 ft. (15.24 m) in front of the wave generators. The generators are computer controlled and capable of producing monochromatic or spectral wave fields.

Two wing walls, 30 ft. (9.14 m) apart, are centered at the end of the basin away from the wave generators. The wing walls are each 30 ft. (9.14 m) long then turn towards the sides of the basin for 10 ft. (3.05 m). Between the wing walls is an 8 ft. (2.44 m) diameter by 8 ft. (2.44 m) deep sump. The sump is equipped with two 4 in. (10.2 cm) diameter pipes with float-controlled submersible pumps and flow meters, and also two external diesel-powered pumps with 15 in. (0.38 m) diameter intakes and 12 in. (0.31 m) diameter outfalls.

During testing of a flood-fighting product, seepage through the structure shall be collected in the sump and pumped back into the basin via the sump pumps and 4-in diameter pipes. The diesel pumps are used during the overtopping tests to return the water to the basin and during the current test to provide water flow.

Seepage rates through the test structures are measured by the flow meters in the 4 in. (10.2 cm) diameter pipes and also by a laser pointing at a float in a standpipe in the sump measuring changes in water surface elevation. Several capacitance-type wave gauges measure the changes in water surface elevation within the basin to determine the incident wave fields. Eight lasers record any movement of the structure during testing.

A cable take-up reel has been modified to tow a log into the structure at a calibrated 5 mph (7 ft/s) (for a debris impact test). The log trips a wire set a few in. in front of the test structure which turns off the drive motor on the take-up reel prior to impact. Two web cams with 360-degree pan and telephoto zoom capabilities are used to record construction, testing, and disassembly of each product. The web cams may also be used to broadcast so that the tests may be viewed in real time by anyone with web access.

Due to the restrictive height of the research basin walls, the height of each structure shall be limited to approximately 3 ft (0.9 m). The ground surface of the wave basin is a smooth, flat, and impervious concrete slab with little elevation changes. The water supply for performance testing shall be the available non-potable (e.g. city water) water supply to the test facility. No purposely contaminated water shall be allowed into the facility.

The wet-side, or river-side, of the wave basin refers to the side of the basin that imposes the flood water. The dry-side of the wave basin refers to the side protected by the temporary perimeter barrier.

Two web cams with 360-degree pan and telephoto zoom capabilities are used to record construction, testing, and disassembly of each product. The web cams may also be used to broadcast so that the tests may be viewed in real time by anyone with web access.

APPENDIX I: Test Facility Description

This space reserved for future test facility description.



Member of the FM Global Group

Printed in USA