

## GT-PX (50YD) Packaged Series

TWO-STAGE  
HORIZONTAL, VERTICAL, AND DOWNFLOW  
PURON® SYSTEMS SIZES 026 - 072 [7.0 - 19.3 kW]

## Table of Contents

What's New with Carrier Geothermal's GT-PX? .....	51	Dimensions — Horizontal GT-PX .....	76
GT-PX Design Features.....	52	Electrical Data.....	78
Unit Model Key.....	54	Standard Electrical Wiring Diagrams .....	79
About ARI/ISO/ASHRAE 13256-1 .....	55	GT-PX ECM Control Features.....	81
ARI/ISO/ASHRAE/ANSI 13256-1 Performance.....	56	GT-PX ECM Control Features.....	82
Reference Calculations & Legend .....	57	Blower Performance Data.....	83
Full Load Correction Factors.....	58	Auxiliary Electric Heat.....	84
Part Load Correction Factors.....	59	Auxiliary Heat Ratings .....	84
Performance Data.....	60	Auxiliary Heat Electrical Data .....	84
Performance Data Selection Notes.....	70	Engineering Guide Specifications.....	85
Physical Data .....	71	Accessories, Options, and Warranty.....	86
Dimensions — Vertical Upflow GT-PX .....	72	Revision History .....	88
Dimensions — Vertical Downflow GT-PX .....	74		

## What's New with Carrier Geothermal's GT-PX?

### Puron® Refrigerant

Puron® is a non-chlorine based (HFC-410A) refrigerant, that with R-407C and R-134A, is seen as the future of all refrigerants used worldwide.

HFC 410A characteristics compared to R-22 are:

- Binary and near azeotropic mixture of 50% R-32 and 50% R-125.
- Higher efficiencies (50-60% higher operating pressures)
- Zero ozone depletion potential and low global warming potential.
- Virtually no glide. Unlike other alternative refrigerants, the two components in HFC 410A have virtually the same leak rates. Therefore, refrigerant can be added if necessary without recovering the charge.

### MERV 11 2" Pleated filter

All GT-PX units include a factory installed 2" filter rack/duct collar with a 2" pleated high efficiency MERV 11 air filter. The MERV (minimum efficiency reporting value per ASHRAE Standard 52.2) design features ultra low velocity (<300 fpm) for extended filter life, low pressure drop (0.13 – 0.18 in. wg.) and high particulate efficiency (size E1=41%, E2=69% and E3=87%). The pleated design and low velocity combine to allow the filter to store a large amount of dirt and result in a practical replacement life of up to 6 months.

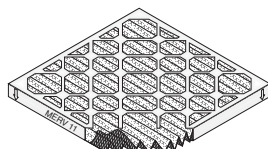

### E-Coated Air Coil

All Carrier Geothermal GT-PX Series models feature an e-coated air-coil. This electro-coating process will provide years of protection against corrosion from airborne chemicals resulting from modern building material out gassing and most environmental chemicals found in the air. Modern building materials such as counter-tops, floor coverings, paints and other materials can "outgas" chemicals into the home's air. Some of these chemicals are suspected of contributing to corrosion in the air coils found in both traditional and geothermal heating and cooling equipment. Corrosion often results in refrigerant leaks and eventual failure of the air coil costing hundreds of dollars to replace. Studies have also shown that these air coil coatings improve moisture shedding and therefore improve a unit's moisture removal capability resulting in a more comfortable home. The GT-PX Series is your assurance of both maximum air coil life and comfort.

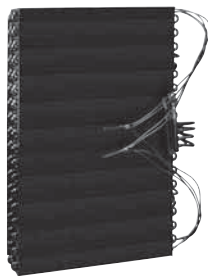

### Copeland Scroll Compressor

Achieve a greater level of comfort. The Copeland Scroll UltraTech™ provides superior comfort than fixed-capacity compressors by incorporating a revolutionary two-step design. With a unique 67% part-load capacity step, systems with UltraTech™ maintain precise



temperature levels and lower relative humidity. This eliminates uneven peaks and valleys and allows for steady cooling comfort. Homeowners now have a better, more efficient way to power their heating and cooling system, raising their level of comfort, while lowering energy bills. So when your customers need a new heating and cooling system, make sure it has the best technology inside – the Copeland Scroll UltraTech™ compressor.

Save with superior efficiency. Over 40% of summer utility bills can come from the air conditioner compressor operation. A system with the Copeland Scroll UltraTech™ compressor delivers higher efficiency than any other single compressor system. In fact, systems with UltraTech™ provide up to 50% greater energy efficiency as compared to 13-SEER systems – which can save homeowners hundreds of dollars a year in energy costs.

Take it easy with quieter control. Copeland Scroll UltraTech™ is remarkably quiet at both full- and part-load capacity. In fact, it is up to four times quieter than a reciprocating compressor. Homeowners can enjoy its superior efficiency and comfort without having to hear the operation.

Learn the beauty of the design. With Copeland Scroll UltraTech™, two internal bypass ports enable the system to run at 67% part-load capacity for better

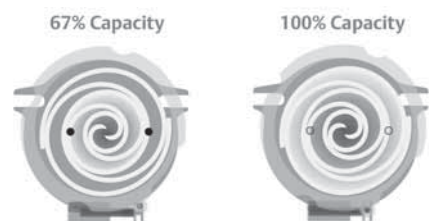

efficiency and humidity control. Based on demand, the modulation ring is activated, sealing the bypass ports and instantly shifting capacity to 100%. Take advantage of "shift on the fly" stage changing (no stopping and starting required like other two-stage compressors).

Choose proven scroll performance. While Copeland Scroll UltraTech™ builds on established scroll technology, it is still a scroll at heart, which means it operates with fewer moving parts, no volumetric efficiency drop-off or compression leakage. The result is unsurpassed reliability and virtually silent operation for both indoor and outdoor applications.

### Other New Features

- Stylish two-tone look with textured black powder coat paint and stainless steel front access panels.
- Liftout handles for front access panels.
- Corrosion and stain resistant stainless steel drain pan with extra slope designed in.
- Factory mounted filter drier for trouble free reliability.
- Easy access low profile horizontal control box.
- Double isolated compressor for quiet and vibration free operation.
- Foil faced insulation in air handling compartment to allow easy cleaning and prevent microfiber introduction into the air stream.
- Open Service-Friendly Cabinet ( i.e., all components in compressor section can be serviced from the front).

## GT-PX Design Features

The GT-PX Series has abundant features and ultra high efficiency.

### Application Flexibility

- Five Capacities 026, 038, 049, 064, and 072.
- Extended range operation (20-120°F EWT) and flow rates as low as 1.5 gpm per ton.
- Vertical packages with either true right or true left return air options.
- Internally trapped condensate drain.
- Variable speed ECM fan motor adapts to various duct systems.
- Internal electric heat unit (optional) designed for easy field installation.
- Circuit breaker protected loop and hot water generator pumps.
- Field selectable freeze protection setting for well or loop.
- Standard pre-installed 2" filter frame with 2" high performance MERV 11 pleated air filter.\*

### Operating Efficiencies

- Puron® HFC 410A zero ozone depletion refrigerant.
- Highest efficiencies in ARI/ISO/ASHRAE/ANSI 13256-1 ratings for heating COP's, cooling EER's with low water flow rates.
- Two-Stage operation for ultra high efficiencies and unsurpassed comfort.
- Operating temperature range and high efficiency allow shorter loops.
- Optional hot water generator with internal pump generates hot water at considerable savings.
- Rugged and highly efficient next generation Copeland UltraTech™ scroll compressors provide ultra high efficiencies and full capacity with reduced cycling losses.
- Oversized coaxial tube water-to-refrigerant heat exchangers operate at low liquid pressure drop. Convuluted copper (and optional cupronickel) water tube functions efficiently at low-flow rates and provides freeze-damage resistance.
- Oversized e-coated, rifled tube/lanced aluminum fin, air to refrigerant heat exchangers provide high efficiency at low face velocity.
- Large low RPM blowers with variable speed fan motors provide quiet, efficient air movement with high static capability.

### Service Advantages

- Removable panels - 3 for compressor 2 for air handling compartment.
- Low profile control box grants easy access to all internal components.
- Factory installed liquid line filter/drier.
- Brass swivel-type water connections for quick connection and elimination of wrenches or sealants during installation.
- Bi-directional thermal expansion valve.
- CXM control features status lights with memory for easy diagnostics.
- Unit Performance Sentinel alerts homeowner of potential performance issues.
- Circuit breaker protected 75VA control transformer.

- ECM control board features thermostat signal diagnostic LED's, airflow display LED (100 CFM per flash), and simplified CFM selection.
- Insulated divider and separate air handling/compressor compartments permit service testing without air bypass.
- Fan motors have quick attach wiring harness for fast removal.
- Internal dropout blower for easy servicing.
- High and low pressure service ports on refrigerant circuit.
- Accurate refrigerant sensing freeze protection.

### Factory Quality

- All units are built on our Integrated Process Control Assembly System (IPCS). The IPCS is a unique state of the art manufacturing system that is designed to assure quality of the highest standards of any manufacturer in the water-source industry. Our IPCS system:
  - Verifies that the correct components are being assembled.
  - Automatically performs special leak tests on all joints.
  - Conducts pressure tests.
  - Performs highly detailed run test unparalleled in the HVAC industry.
  - Automatically disables packaging for a "failed" unit.
  - Creates computer database for future service analysis an diagnostics from run test results.
- All units are water run-tested in all modes to insure efficiency and reliability.
- Heavy gauge galvanized steel cabinets are epoxy powder coated for durable and long-lasting finish.
- All refrigerant brazing is done in a nitrogen atmosphere.
- All units are deep evacuated to less than 100 microns prior to refrigerant charging.
- All joints are both helium and halogen leak tested to insure annual leak rate of less than 1/4 ounce.
- Coaxial heat exchanger, refrigerant suction lines and all water lines are fully insulated to eliminate condensation problems in low temperature applications.
- Noise Reduction features include: double isolation mounted compressors; insulated compressor compartment; interior cabinet insulation using 1/2" coated glass fiber and variable speed fan.
- Safety features include: high pressure and loss of charge to protect the compressor; condensate overflow protection; freeze protection sensors to safeguard the coaxial heat exchanger and air coil; hot water high-limit and low compressor discharge temperature switch provided to shut down the hot water generator when conditions dictate. Fault lockout enables emergency heat and prevents compressor operation until thermostat or circuit breaker has been reset.

## GT-PX Design Features

### Simplified Controls

- CXM solid state control module.
- 'CFM' LED displays airflow.
- Dehumidification mode for higher latent cooling.

### Options & Accessories

- Optional hot water generator with internally mounted pump.
- Optional cupronickel coaxial heat exchanger.
- Electronic thermostat.
- Closed loop Flow Controller.
- Electronic auto-changeover thermostat with 3-stage heat, 2-stage cool and indicator LED's.
- Hose kits.
- Optional Whole House Dehumidification.

- 1 Copeland™ Ultra-Tech™ Two-Stage Unloading Scroll Compressor
- 2 State-Of-The-Art Variable Speed Blower Motor
- 3 E-Coated Air Coil
- 4 Foil Faced Insulation In The Blower Section, Fully Insulated Compressor Section
- 5 Two Inch Filter Frame With High Performance MERV 11 Pleated Air Filter\*
- 6 Stainless Steel Drain Pan For Long Life
- 7 Unit Performance Sentinel: Automatic Alert System Lets You Know If The System Is Not Running At Peak Performance\*\*
- 8 Exclusive Double Spring And Grommet Compressor Isolation For Ultra Quiet Operation
- 9 Five Easy, Lift-out Service Access Panels With Stainless Steel Front Panels

\* MERV= Minimum Efficiency Reporting Value as specified by ASHRAE (American Society of Heating, Refrigerating and Air Conditioning Engineers) standard 52.2.

\*\* When installed with a Carrier Geothermal Residential Thermostat.

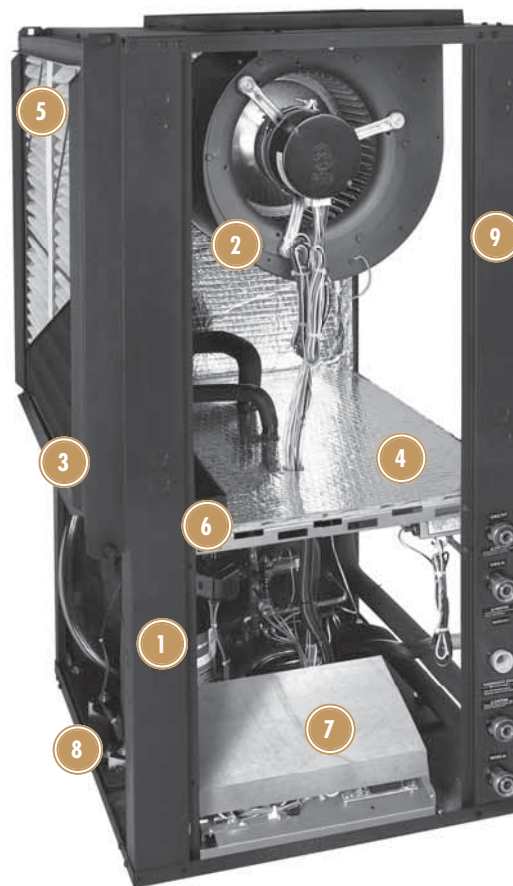

Features Puron®  
HFC-410A Zero Ozone  
Depletion Refrigerant

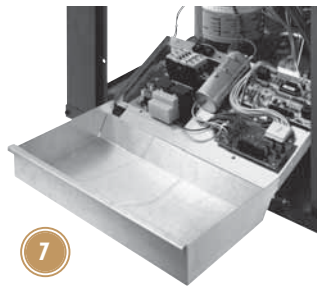
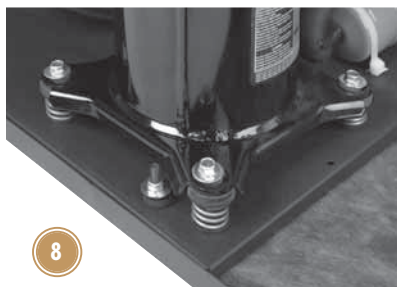

## Unit Model Key

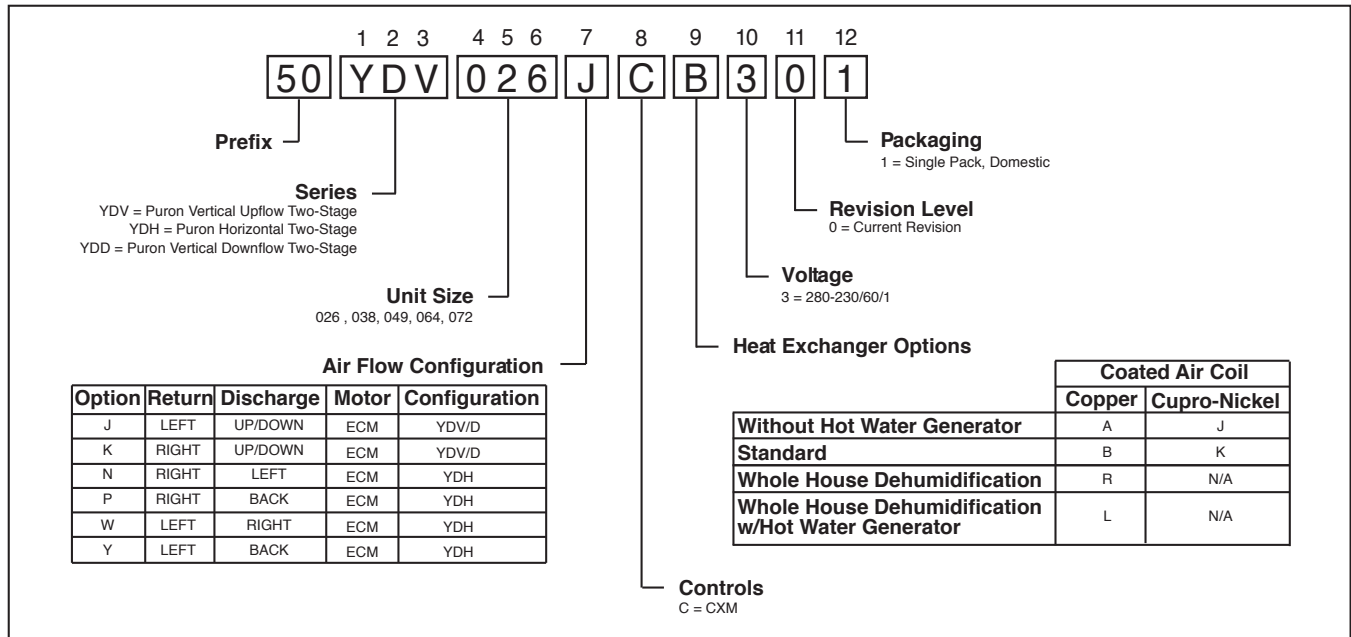

## About ARI/ISO/ASHRAE 13256-1

### About ARI/ISO/ASHRAE 13256-1

ARI/ASHRAE/ISO 13256-1 (Air-Conditioning and Refrigeration Institute/American Society of Heating, Refrigerating and Air Conditioning Engineers/International Standards Organization) is a certification standard for water-source heat pumps used in the following applications:

- WLHP (Water Loop Heat Pump – Boiler/Tower)
- GWHP (Ground Water Heat Pump – Open Loop)
- GLHP (Ground Loop Heat Pump – Geothermal)

The directory at <http://www.aridirectory.org/ari/wbahrp.php> is constantly being updated and immediately available on the Internet. All ratings are submitted by the manufacturer for certification, and must be approved by ARI. Therefore, there is a significant difference between ARI “certified” and ARI “rated.” Thirty percent of a manufacturer’s basic models must be tested each year. ARI selects models at random from stock for testing on the basis of its evaluation of a participant’s certification data.

Units that fail one or more certified test (90% of declared performance or lower) may be declared defective. If the initial failure is a performance test, the manufacturer must obsolete all units within the same basic model group or elect to have a second sample tested. If the second unit fails a performance test, it must be obsoleted, together with all units within the same basic model group. Carrier Geothermal takes certification seriously. We were recently awarded a certificate for consecutive years of no ARI failures.

Temperatures used in ARI certification standards are S.I. (Système International – metric) based. For example, typical catalog data for cooling is shown at 80°F DB/67°F WB [26.7°C DB/19.4°C] entering air temperature, but the ARI standard for cooling is 80.6°F DB/66.2°F WB [27°C DB/19°C], since it is based upon whole numbers in degrees Celsius. Water and air temperatures for the standard are shown below.

### Test Condition Comparison Table

	WLHP	GWHP	GLHP
<b>Cooling</b>			
Entering Air Temperature - DB/WB °F [°C]	80.6/66.2 [27/19]	80.6/66.2 [27/19]	80.6/66.2 [27/19]
Entering Water Temperature - °F [°C]	86 [30]	59 [15]	77 [25]
Fluid Flow Rate	*	*	*
<b>Heating</b>			
Entering Air Temperature - DB/WB °F [°C]	68 [20]	68 [20]	68 [20]
Entering Water Temperature - °F [°C]	68 [20]	50 [10]	32 [0]
Fluid Flow Rate	*	*	*

\*Flow rate is specified by the manufacturer

Data certified by ARI include heating/cooling capacities, EER (Energy Efficiency Ratio – Btuh per Watt) and COP (Btuh per Btuh) at the various conditions shown above. Pump power correction is calculated to adjust efficiencies for pumping Watts. Within each model, only one water flow rate is specified for all three groups, and pumping Watts are calculated using the formula below. This additional power is added onto the existing power consumption.

- Pump power correction =  $(\text{gpm} \times 0.0631) \times (\text{Press Drop} \times 2990)/300$

Fan power is corrected to zero external static pressure using the equation below. The nominal airflow is rated at a specific external static pressure. This effectively reduces the power consumption of the unit and increases cooling capacity but decreases heating capacity.

- Fan Power Correction =  $(\text{cfm} \times 0.472) \times (\text{esp} \times 249)/300$

Capacities and efficiencies are calculated using the following equations:

- ISO Cooling Capacity = Cooling Capacity (Btuh) + [Fan Power Correction (Watts) × 3.412]
- ISO EER Efficiency (Btuh/W) =  
ISO Cooling Capacity (Btuh)/[Power Input (Watts) – Fan Power Correction (Watts) + Pump Power Correction (Watts)]
- ISO Heating Capacity = Heating Capacity (Btuh) – [Fan Power Correction (Watts) × 3.412]
- ISO COP Efficiency (Btuh/Btuh) =  
ISO Heating Capacity (Btuh) × 3.412/[Power Input (Watts) – Fan Power Correction (Watts) + Pump Power Correction (Watts)]

## ARI/ISO/ASHRAE/ANSI 13256-1 Performance

ASHRAE/ARI/ISO 13256-1. English (IP) Units

Model	Capacity Modulation	Water Loop Heat Pump				Ground Water Heat Pump				Ground Loop Heat Pump			
		Cooling 86°F		Heating 68°F		Cooling 59°F		Heating 50°F		Cooling Full Load 77°F Part Load 68°F		Heating Full Load 32°F Part Load 41°F	
		Capacity Btuh	EER Btuh/W	Capacity Btuh	COP	Capacity Btuh	EER Btuh/W	Capacity Btuh	COP	Capacity Btuh	EER Btuh/W	Capacity Btuh	COP
026	Full	25,300	15.9	30,800	5.3	28,900	24.5	25,700	4.8	26,600	18.5	19,800	4.0
	Part	19,400	18.3	22,400	6.1	22,200	30.8	18,600	5.1	21,300	26.0	16,500	4.6
038	Full	36,200	15.6	44,800	5.3	41,200	23.0	36,700	4.7	38,200	18.2	29,000	4.0
	Part	26,200	18.5	30,800	6.3	30,200	31.5	24,800	5.1	28,900	27.0	22,100	4.5
049	Full	48,400	15.7	59,900	5.2	54,600	22.5	48,300	4.7	50,600	17.9	37,500	4.0
	Part	36,100	18.0	44,300	6.2	40,700	28.7	35,400	5.1	39,600	24.9	31,200	4.6
064	Full	61,500	15.0	72,300	5.0	68,600	22.0	59,600	4.4	64,800	17.5	48,000	3.9
	Part	44,900	17.6	51,100	5.7	51,900	29.7	41,800	4.7	49,800	25.3	37,500	4.3
072	Full	68,700	14.2	88,600	4.9	77,100	19.9	70,200	4.3	71,600	16.2	54,100	3.6
	Part	52,800	16.0	65,200	5.1	59,800	24.5	51,700	4.3	57,700	21.4	45,400	3.9

Cooling capacities based upon 80.6°F DB, 66.2°F WB entering air temperature  
 Heating capacities based upon 68°F DB, 59°F WB entering air temperature  
 Ground Loop Heat Pump ratings based on 15% antifreeze solution  
 All ratings based upon operation at lower voltage of dual voltage rated models

ASHRAE/ARI/ISO 13256-1. Metric (SI) Units

Model	Capacity Modulation	Water Loop Heat Pump				Ground Water Heat Pump				Ground Loop Heat Pump			
		Cooling 30°C		Heating 20°C		Cooling 15°C		Heating 10°C		Cooling Full Load 25°C Part Load 20°C		Heating Full Load 0°C Part Load 5°C	
		Capacity Watts	EER W/W	Capacity Watts	COP	Capacity Watts	EER W/W	Capacity Watts	COP	Capacity Watts	EER W/W	Capacity Watts	COP
026	Full	7,415	4.7	9,027	5.3	8,470	7.2	7,532	4.8	7,796	5.4	5,803	4.0
	Part	5,686	5.4	6,565	6.1	6,506	9.0	5,451	5.1	6,243	7.6	4,836	4.6
038	Full	10,610	4.6	13,130	5.3	12,075	6.7	10,756	4.7	11,196	5.3	8,499	4.0
	Part	7,679	5.4	9,027	6.3	8,851	9.2	7,268	5.1	8,470	7.9	6,477	4.5
049	Full	14,185	4.6	17,556	5.2	16,002	6.6	14,156	4.7	14,830	5.2	10,991	4.0
	Part	10,580	5.3	12,984	6.2	11,928	8.4	10,375	5.1	11,606	7.3	9,144	4.6
064	Full	18,025	4.4	21,190	5.0	20,106	6.4	17,468	4.4	18,992	5.1	14,068	3.9
	Part	13,159	5.2	14,977	5.7	15,211	8.7	12,251	4.7	14,596	7.4	10,991	4.3
072	Full	20,135	4.2	25,967	4.9	22,597	5.8	20,574	4.3	20,985	4.7	15,856	3.6
	Part	15,475	4.7	19,109	5.1	17,526	7.2	15,152	4.3	16,911	6.3	13,306	3.9

Cooling capacities based upon 27°C DB, 19°C WB entering air temperature  
 Heating capacities based upon 20°C DB, 15°C WB entering air temperature  
 Ground Loop Heat Pump ratings based on 15% antifreeze solution  
 All ratings based upon operation at lower voltage of dual voltage rated models



## Reference Calculations & Legend

Heating		Cooling	
$LWT = EWT - \frac{HE}{GPM \times 500}$	$LWT = EWT + \frac{HR}{GPM \times 500}$	$LC = TC - SC$	
$LAT = EAT + \frac{HC}{CFM \times 1.08}$	$LAT (DB) = EAT (DB) - \frac{SC}{CFM \times 1.08}$	$S/T = \frac{SC}{TC}$	

Hot Water Generator capacities (HWC) are based on potable water flow rate of 0.4 gpm per nominal equipment ton and 90°F entering potable water temperature.

CFM = airflow, cubic feet/minute	HE = total heat of extraction, Mbtuh
EWT = entering water temperature, °F	HWC = Hot Water Generator (desuperheater) capacity, Mbtuh
GPM = water flow in US gallons/minute	WPD = Water coil pressure drop (psi & ft hd)
EAT = entering air temperature, Fahrenheit (dry bulb/wet bulb)	EER = Energy Efficiency Ratio = BTU output/Watt input
HC = air heating capacity, Mbtuh	COP = Coefficient of Performance = BTU output/BTU input
TC = total cooling capacity, Mbtuh	LWT = leaving water temperature, °F
SC = sensible cooling capacity, Mbtuh	LAT = leaving air temperature, °F
KW = total power unit input, KiloWatts	LC = latent cooling capacity, Mbtuh
HR = total heat of rejection, Mbtuh	S/T = sensible to total cooling ratio

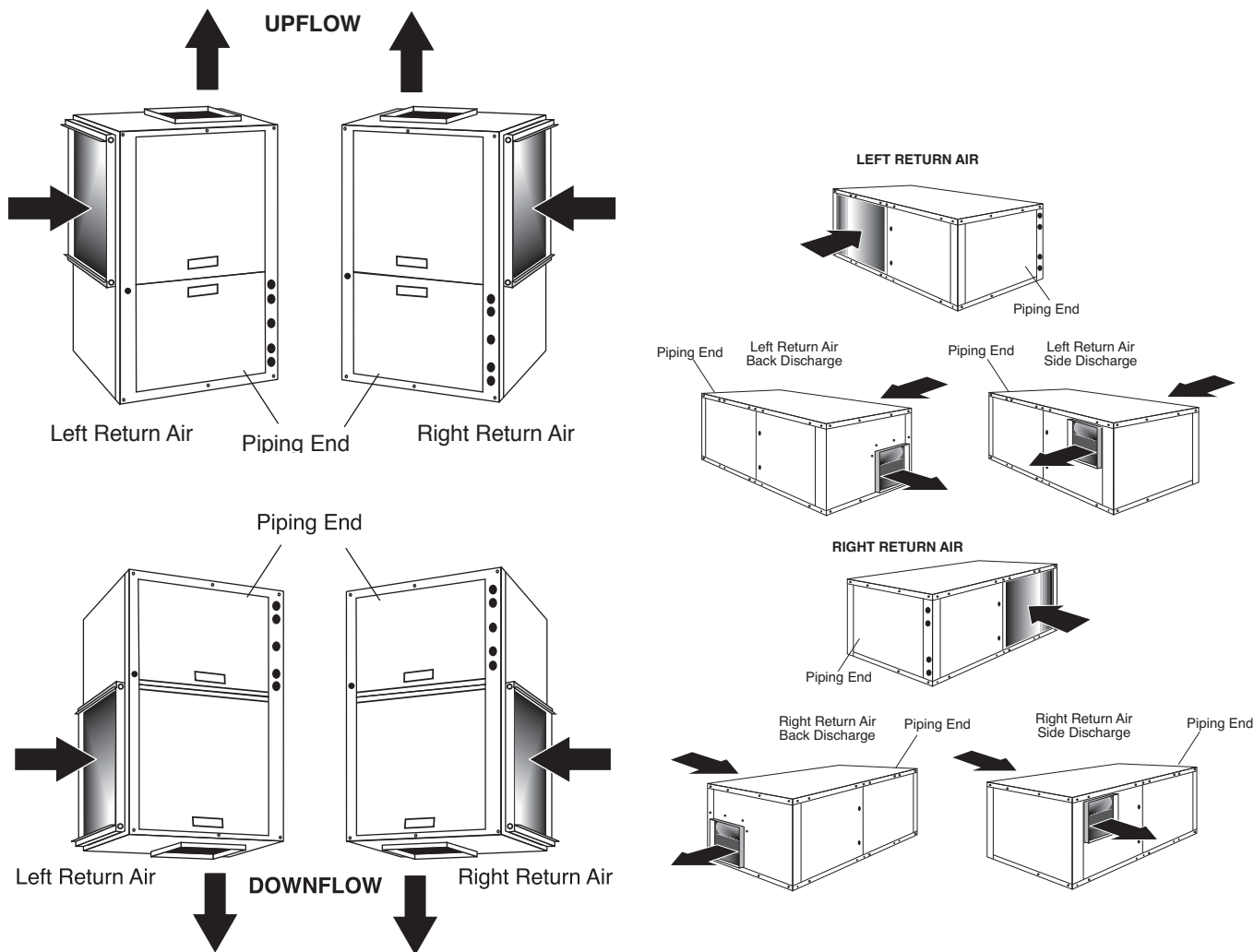

## Full Load Correction Factors

### Air Flow Correction Table

Airflow	Cooling				Heating		
	Total Capacity	Sensible Capacity	Power	Heat of Rejection	Heating Capacity	Power	Heat of Extraction
60%	0.925	0.788	0.913	0.922	0.946	1.153	0.896
69%	0.946	0.829	0.926	0.942	0.959	1.107	0.924
75%	0.960	0.861	0.937	0.955	0.969	1.078	0.942
81%	0.972	0.895	0.950	0.968	0.977	1.053	0.959
88%	0.983	0.930	0.965	0.979	0.985	1.032	0.974
94%	0.992	0.965	0.982	0.990	0.993	1.014	0.988
100%	1.000	1.000	1.000	1.000	1.000	1.000	1.000
106%	1.007	1.033	1.020	1.009	1.006	0.989	1.011
113%	1.012	1.064	1.042	1.018	1.012	0.982	1.019
119%	1.016	1.092	1.066	1.025	1.018	0.979	1.027
125%	1.018	1.116	1.091	1.032	1.022	0.977	1.033
130%	1.019	1.132	1.112	1.037	1.026	0.975	1.038

### Entering Air Correction Table

Heating			
Entering Air DB°F	Heating Capacity	Power	Heat of Extraction
40	1.052	0.779	1.120
45	1.043	0.808	1.102
50	1.035	0.841	1.084
55	1.027	0.877	1.065
60	1.019	0.915	1.045
65	1.010	0.957	1.023
68	1.004	0.982	1.010
70	1.000	1.000	1.000
75	0.989	1.045	0.974
80	0.976	1.093	0.946

\* = Sensible capacity equals total capacity  
 ARI/ISO/ASHRAE 13256-1 uses entering air conditions of Cooling - 80.6°F DB/66.2°F WB,  
 and Heating - 68°F DB/59°F WB entering air temperature

Entering Air WB°F	Total Capacity	Cooling										Power	Heat of Rejection
		Sensible Cooling Capacity Multiplier - Entering DB °F											
		60	65	70	75	80	80.6	85	90	95	100		
45	0.832	1.346	1.461	1.603	*	*	*	*	*	*	*	0.946	0.853
50	0.850	1.004	1.174	1.357	*	*	*	*	*	*	*	0.953	0.870
55	0.880	0.694	0.902	1.115	1.331	*	*	*	*	*	*	0.964	0.896
60	0.922		0.646	0.875	1.103	1.329	1.356	*	*	*	*	0.977	0.932
65	0.975			0.639	0.869	1.096	1.123	1.320	*	*	*	0.993	0.979
66.2	0.990			0.582	0.812	1.039	1.066	1.262	1.482	*	*	0.997	0.991
67	1.000			0.545	0.774	1.000	1.027	1.223	1.444	*	*	1.000	1.000
70	1.040				0.630	0.853	0.880	1.075	1.297	1.517	*	1.011	1.035
75	1.117					0.601	0.627	0.821	1.046	1.275	1.510	1.033	1.101

### Air Flow Correction Table

Airflow	Cooling				Heating		
	Total Capacity	Sensible Capacity	Power	Heat of Rejection	Heating Capacity	Power	Heat of Extraction
60%	0.920	0.781	0.959	0.927	0.946	1.241	0.881
69%	0.942	0.832	0.964	0.946	0.960	1.163	0.915
75%	0.956	0.867	0.696	0.959	0.969	1.115	0.937
81%	0.969	0.901	0.975	0.970	0.978	1.076	0.956
88%	0.981	0.934	0.982	0.981	0.986	1.043	0.973
94%	0.991	0.967	0.990	0.991	0.993	1.018	0.988
100%	1.000	1.000	1.000	1.000	1.000	1.000	1.000
106%	1.007	1.033	1.011	1.008	1.006	0.990	1.010
113%	1.013	1.065	1.023	1.015	1.012	0.986	1.017
119%	1.018	1.098	1.036	1.021	1.017	0.983	1.024
125%	1.021	1.131	1.051	1.026	1.021	0.981	1.030
130%	1.023	1.159	1.063	1.030	1.024	0.979	1.034

### Entering Air Correction Table

Heating			
Entering Air DB°F	Heating Capacity	Power	Heat of Extraction
40	1.084	0.732	1.161
45	1.073	0.764	1.140
50	1.060	0.802	1.117
55	1.046	0.846	1.090
60	1.031	0.893	1.061
65	1.016	0.945	1.031
68	1.006	0.978	1.013
70	1.000	1.000	1.000
75	0.984	1.058	0.968
80	0.968	1.117	0.936

\* = Sensible capacity equals total capacity  
 ARI/ISO/ASHRAE 13256-1 uses entering air conditions of Cooling - 80.6°F DB/66.2°F WB,  
 and Heating - 68°F DB/59°F WB entering air temperature

Entering Air WB°F	Total Capacity	Cooling										Power	Heat of Rejection
		Sensible Cooling Capacity Multiplier - Entering DB °F											
		60	65	70	75	80	80.6	85	90	95	100		
45	0.876	1.286	1.302	1.389	*	*	*	*	*	*	*	0.981	0.895
50	0.883	1.002	1.099	1.241	*	*	*	*	*	*	*	0.985	0.901
55	0.903	0.706	0.871	1.060	1.271	*	*	*	*	*	*	0.989	0.918
60	0.935		0.617	0.844	1.079	1.319	1.349	*	*	*	*	0.993	0.945
65	0.979			0.595	0.849	1.096	1.128	1.342	*	*	*	0.998	0.982
66.2	0.991			0.531	0.789	1.040	1.070	1.284	1.522	*	*	0.999	0.993
67	1.000			0.486	0.747	1.000	1.030	1.245	1.481	*	*	1.000	1.000
70	1.035				0.583	0.842	0.873	1.090	1.327	1.552	*	1.003	1.030
75	1.105					0.552	0.584	0.811	1.057	1.290	1.510	1.008	1.088























## Performance Data Selection Notes

For operation in the shaded area when water is used in lieu of an anti-freeze solution, the LWT (Leaving Water Temperature) must be calculated. Flow must be maintained to a level such that the LWT is maintained above 40°F [4.4°C] when the JW3 jumper is not clipped (see example below). This is due to the potential of the refrigerant temperature being as low as 32°F [0°C] with 40°F [4.4°C] LWT, which may lead to a nuisance cutout due to the activation of the Low Temperature Protection. JW3 should never be clipped for standard range equipment or systems without antifreeze.

### Example:

At 50°F EWT (Entering Water Temperature) and 1.5 gpm/ton, a 3 ton unit has a HE of 22,500 Btuh. To calculate LWT, rearrange the formula for HE as follows:

$HE = TD \times GPM \times 500$ , where HE = Heat of Extraction (Btuh);  
 TD = temperature difference (EWT - LWT) and GPM = U.S. Gallons per Minute.

$$TD = HE / (GPM \times 500)$$

$$TD = 22,500 / (1.5 \times 500)$$

$$TD = 10^\circ F$$

$$LWT = EWT - TD$$

$$LWT = 50 - 10 = 40^\circ F$$

In this example, as long as the EWT does not fall below 50°F, the system will operate as designed. For EWTs below 50°F, higher flow rates will be required (open loop systems, for example, require at least 2 gpm/ton when EWT is below 50°F).

Performance capacities shown in thousands of Btuh

Heating - EAT 70°F							
HWC	Airflow CFM	HC	kW	HE	LAT	COP	HWC
	1850	44.6	4.82	28.8	92.3	2.7	4.9
	2100	45.3	4.67	29.6	90.0	2.8	5.0
2	1850	49.0	4.89	32.8	94.5	2.9	5.8
3.0	2100	49.7	4.74	33.7	91.9	3.1	5.9
3.3	1850	51.1	4.94	34.8	95.6	3.0	5.8
4.1	2100	51.9	4.78	35.7	92.9	3.2	5.9
4.5	1850	52.3	4.96	35.8	96.2	3.1	5.8
4.3	2100	53.1	4.81	36.8	93.4	3.2	5.9
5.1	1850	56.8	5.06	40.0	98.4	3.3	6.6
5.9	2100	57.7	4.90	41.1	95.4	3.4	6.7
6.0	1850	59.7	5.13	42.7	99.9	3.4	6.6
	2100	60.6	4.97	43.8	96.7	3.6	6.7
	1850	61.4	5.17	44.2	100.7	3.5	6.6
	2100	62.3	5.01	45.3	97.5	3.6	6.7
3.6	1850	65.5	5.27	47.9	102.8	3.6	7.4
3.7	2100	66.5	5.11	49.1	99.3	3.8	7.6
3	1850	69.3	5.37	51.3	104.7	3.8	7.7
	2100	70.3	5.21	52.7	101.0	4.0	7.7
	1850	71.4	5.43	53.2	105.7	3.9	7.7
	2100	72.5	5.26	54.6	102.0	4.1	7.7
		74.7	5.52	56.1	107.4	4.1	7.7
		75.8	5.35	57.6	103.7	4.2	7.7

Model	026	038	049	064	072
Compressor (1 Each)	Copeland UltraTech Two-Stage Scroll				
Factory Charge R410a, oz [kg]	58 [1.64]	78 [2.21]	81 [2.30]	144 [4.08]	156 [4.42]
<b>ECM Fan Motor &amp; Blower Wheel</b>					
Fan Motor Type & Speeds	ECM Variable Speed				
Fan Motor, hp [W]	1/2 [373]	1/2 [373]	1 [746]	1 [746]	1 [746]
Blower Wheel Size (Dia x W), in [mm]	9 x 7 [229 x 178]	11 x 10 [279 x 254]	11 x 10 [279 x 254]	11 x 10 [279 x 254]	11 x 10 [279 x 254]
<b>Water Connection Size</b>					
Swivel - Residential Class	1"	1"	1"	1"	1"
<b>HWG Water Connection Size</b>					
Swivel - Residential Class	1"	1"	1"	1"	1"
<b>Vertical Upflow/Downflow</b>					
Air Coil Dimensions (H x W), in [mm]	28 x 20 [711 x 542]	28 x 25 [711 x 635]	32 x 25 [813 x 635]	36 x 25 [914 x 635]	36 x 25 [914 x 635]
Standard Filter - 2" [51mm] Pleated MERV11 Throwaway, in [mm]	28 x 24 [712 x 610]	28 x 29.5 [712 x 749]	32 x 29.5 [813 x 749]	36 x 29.5 [914 x 749]	36 x 29.5 [914 x 749]
Weight - Operating, lbs [kg]	266 [120.7]	327 [148.6]	416 [189.1]	443 [201.4]	443 [201]
Weight - Packaged, lbs [kg]	276 [125.2]	337 [153.2]	426 [193.6]	453 [205.9]	453 [206]
<b>Horizontal</b>					
Air Coil Dimensions (H x W), in [mm]	18 x 31 [457 x 787]	20 x 35 [508 x 889]	20 x 40 [508 x 1018]	20 x 45 [508 x 1143]	20 x 45 [508 x 1143]
Standard Filter - 2" [51mm] Pleated MERV11 Throwaway, in [mm]	2 - 18 x 18 [457 x 457]	1 - 12 x 20 [305 x 508] 1 - 20 x 25 [508 x 635]	1 - 18 x 20 [457 x 508] 1 - 20 x 24 [508 x 610]	2 - 20 x 24 [508 x 610]	2 - 20 x 24 [508 x 610]
Weight - Operating, lbs [kg]	266 [120.7]	327 [148.6]	416 [189.1]	443 [201.4]	443 [201]
Weight - Packaged, lbs [kg]	276 [125.2]	337 [153.2]	426 [193.6]	453 [205.9]	453 [206]

All units have spring compressor mountings, TXV expansion devices, and 1/2" [12.7mm] & 3/4" [19.1mm] electrical knockouts.

## Dimensions — Vertical Upflow GT-PX

Vertical Upflow Model		Overall Cabinet		
		A Width	B Depth	C Height
026	in cm	22.4 56.8	25.6 65.1	48.5 123.2
038	in cm	25.4 64.5	30.6 77.8	50.5 128.3
049	in cm	25.4 64.5	30.6 77.8	54.5 138.4
064	in cm	25.4 64.5	30.6 77.8	58.5 148.6
072	in cm	25.4 64.5	30.6 77.8	58.5 148.6

Vertical Upflow Model		Water Connections						
		1	2	3	4	5		
		D In	E Out	F HWG IN	G HWG Out	H Condensate	Loop Water IPT	HWG IPT
026	in cm	2.1 5.2	10.0 25.4	13.9 35.2	16.9 42.9	7.8 19.8	1" Swivel	1" Swivel
038	in cm	3.4 8.6	10.8 27.5	15.6 39.7	18.9 47.9	7.8 19.8	1" Swivel	1" Swivel
049	in cm	3.4 8.6	10.8 27.5	15.6 39.7	18.9 47.9	7.8 19.8	1" Swivel	1" Swivel
064	in cm	3.4 8.6	10.8 27.5	15.6 39.7	18.9 47.9	7.8 19.8	1" Swivel	1" Swivel
072	in cm	3.4 8.6	10.8 27.5	15.6 39.7	18.9 47.9	7.8 19.7	1" Swivel	1" Swivel

Vertical Upflow Model		Electrical Knockouts		
		J 1/2"	K 1/2"	L 3/4"
		Low Voltage	External Pump	Power Supply
026	in cm	3.6 9.2	6.1 15.6	8.6 21.9
038	in cm	3.6 9.2	6.1 15.6	8.6 21.9
049	in cm	3.6 9.2	6.1 15.6	8.6 21.9
064	in cm	3.6 9.2	6.1 15.6	8.6 21.9
072	in cm	3.6 9.2	6.1 15.6	8.6 21.9

Condensate is 3/4" PVC female glue socket and is switchable from front to side.  
 Unit shipped with deluxe duct collar/filter rack extending from unit 3" [7.6cm] and is suitable for duct connection.  
 Discharge flange is field installed.



## Dimensions — Vertical Upflow GT-PX

Vertical Upflow Model		Discharge Connection Duct Flange Installed (+/- 0.10 in, +/- 2.5mm)					Return Connection Standard Deluxe Filter Rack (+/- 0.10 in, +/- 2.5mm)			
		M Left Return	N	O Supply Width	P Supply Depth	Q Right Return	R	S Return Depth	T Return Height	U
026	in cm	7.8 18.3	5.8 14.8	14.0 35.6	14.0 35.6	4.9 12.4	1.7 4.2	22.2 56.4	26.2 66.4	1.5 3.9
038	in cm	6.4 16.1	6.3 16.0	18.0 45.7	18.0 45.7	5.3 13.5	2.1 5.4	27.1 68.9	26.1 66.4	1.5 3.9
049	in cm	6.4 16.1	6.3 16.0	18.0 45.7	18.0 45.7	5.3 13.5	2.1 5.4	27.1 68.9	30.1 76.5	1.5 3.9
064	in cm	6.4 16.1	6.3 16.0	18.0 45.7	18.0 45.7	5.3 13.5	2.1 5.4	27.1 68.9	34.1 86.7	1.5 3.9
072	in cm	6.4 16.1	6.3 16.0	18.0 45.7	18.0 45.7	5.3 13.5	2.1 5.4	27.1 68.9	34.1 86.7	1.5 3.9

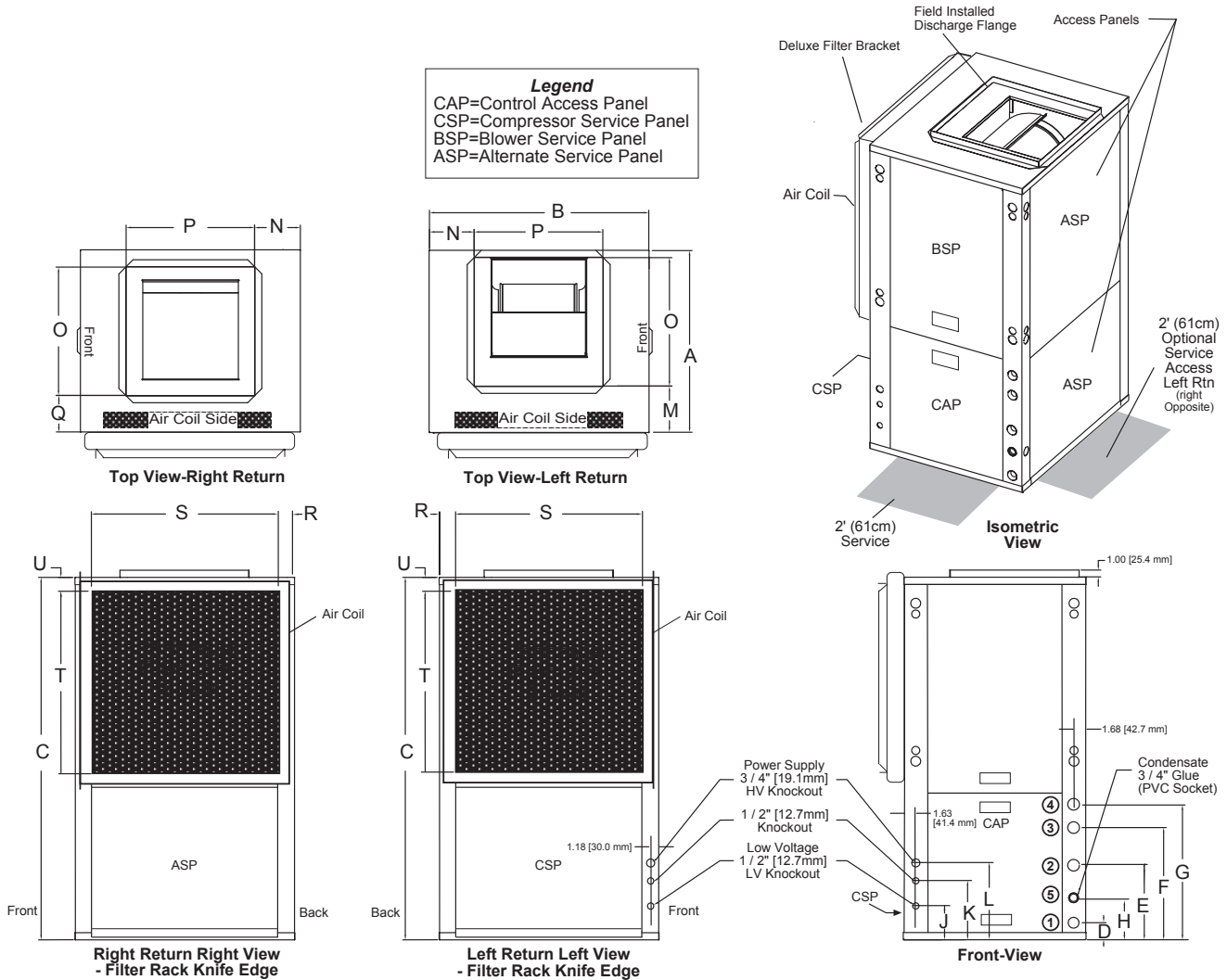

## Dimensions — Vertical Downflow GT-PX

Vertical Downflow Model		Overall Cabinet		
		A Width	B Depth	C Height
026	in cm	22.4 56.8	25.6 65.1	52.5 133.4
038	in cm	25.4 64.5	30.6 77.8	54.5 138.4
049	in cm	25.4 64.5	30.6 77.8	58.5 148.6
064	in cm	25.4 64.5	30.6 77.8	62.5 158.8
072	in cm	25.4 64.5	30.6 77.8	62.5 158.8

Vertical Downflow Model		Water Connections						
		1	2	3	4	5		
		D In	E Out	F HWG IN	G HWG Out	H Condensate	Loop Water IPT	HWG IPT
026	in cm	17.2 43.7	9.3 23.6	5.4 13.7	2.4 6.1	3.6 9.2	1" Swivel	1" Swivel
038	in cm	17.9 45.5	10.5 26.7	5.7 14.5	2.4 6.1	3.6 9.2	1" Swivel	1" Swivel
049	in cm	17.9 45.5	10.5 26.7	5.7 14.5	2.4 6.1	3.6 9.2	1" Swivel	1" Swivel
064	in cm	17.9 45.5	10.5 26.7	5.7 14.5	2.4 6.1	3.6 9.2	1" Swivel	1" Swivel
072	in cm	17.9 45.5	10.5 26.7	5.7 14.5	2.4 6.1	3.6 9.2	1" Swivel	1" Swivel

Vertical Downflow Model		Electrical Knockouts		
		J 1/2"	K 1/2"	L 3/4"
		Low Voltage	External Pump	Power Supply
026	in cm	15.7 39.9	13.2 33.5	10.7 27.2
038	in cm	17.7 45.0	15.2 38.6	12.7 32.3
049	in cm	17.7 45.0	15.2 38.6	12.7 32.3
064	in cm	17.7 45.0	15.2 38.6	12.7 32.3
072	in cm	17.7 45.0	15.2 38.6	12.7 32.3

Condensate is 3/4" PVC female glue socket and is switchable from front to side.  
 Unit shipped with deluxe duct collar/filter rack extending from unit 3" [7.6cm] and is suitable for duct connection.  
 Downflow unit does not have discharge flange, and is rated for zero clearance installation.

## Dimensions — Vertical Downflow GT-PX

Vertical Downflow Model		Discharge Connection Duct Flange Installed (+/- 0.10 in, +/- 2.5mm)					Return Connection Standard Deluxe Filter Rack (+/- 0.10 in, +/- 2.5mm)			
		M Left Return	N	O Supply Width	P Supply Depth	Q Right Return	R	S Return Depth	T Return Height	U
026	in cm	6.7 17.1	8.4 21.4	9.9 25.3	9.1 23.0	10.8 27.4	1.7 4.2	22.2 56.4	26.2 66.4	21.2 53.9
038	in cm	7.4 18.7	9.0 22.9	13.1 33.3	12.9 32.7	10.4 26.5	1.7 4.2	27.1 68.9	26.1 66.4	23.2 59.0
049	in cm	7.4 18.7	9.0 22.9	13.1 33.3	12.9 32.7	10.4 26.5	1.7 4.2	27.1 68.9	30.1 76.5	23.2 59.0
064	in cm	7.4 18.7	9.0 22.9	13.1 33.3	12.9 32.7	10.4 26.5	1.7 4.2	27.1 68.9	34.1 86.7	23.2 59.0
072	in cm	7.4 18.7	9.0 22.9	13.1 33.3	12.9 32.7	10.4 26.5	1.7 4.2	27.1 68.9	34.1 86.7	23.2 59.0

**Legend**  
 CAP=Control Access Panel  
 CSP=Compressor Service Panel  
 BSP=Blower Service Panel  
 ASP=Alternate Service Panel

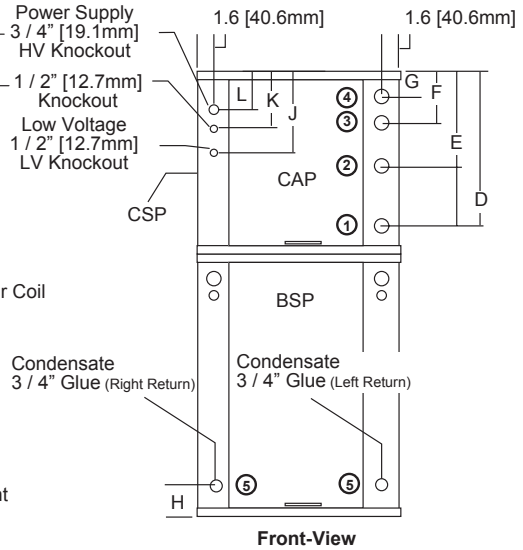
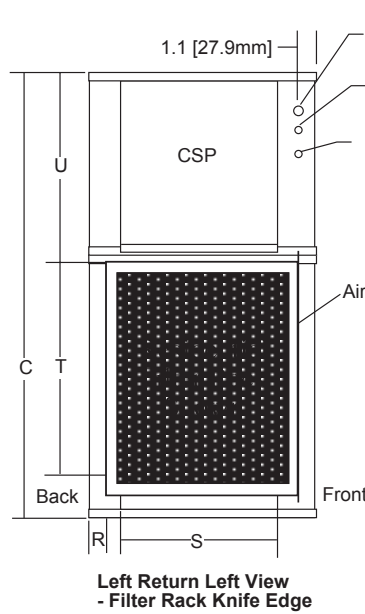
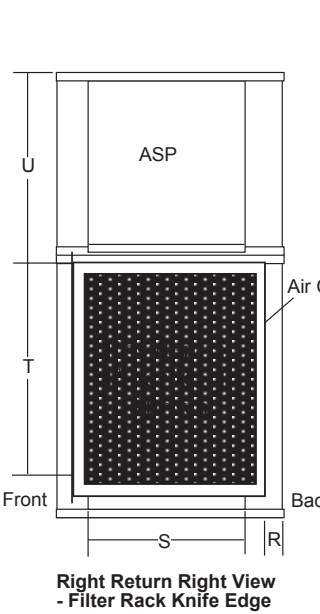
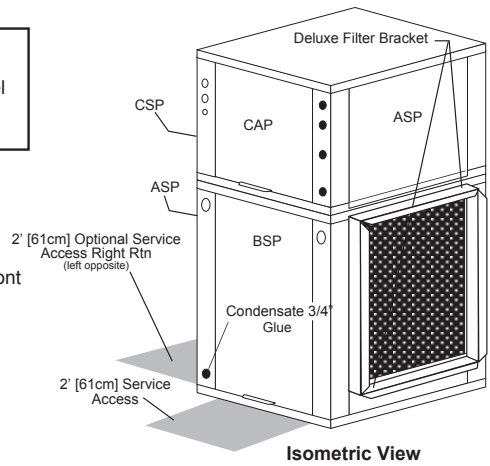
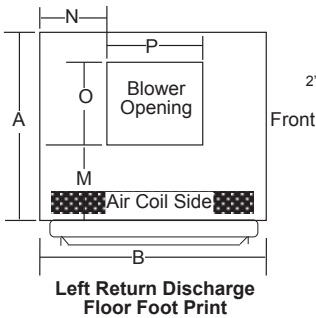
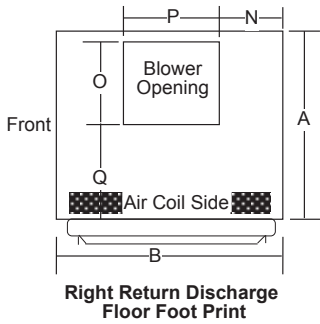

## Dimensions — Horizontal GT-PX

Horizontal Model		Overall Cabinet		
		A Width	B Depth	C Height
026	in cm	22.4 56.8	62.2 158.0	19.3 48.9
038	in cm	25.4 64.5	71.2 180.8	21.3 54.0
049	in cm	25.4 64.5	76.2 193.5	21.3 54.0
064	in cm	25.4 64.5	81.2 206.2	21.3 54.0
072	in cm	25.4 64.5	81.2 206.2	21.3 54.0

Horizontal Model		Water Connections						
		1	2	3	4	5		
		D In	E Out	F HWG IN	G HWG Out	H Condensate	Loop Water IPT	HWG IPT
026	in cm	2.1 5.2	10.0 25.4	13.9 35.2	16.9 42.9	0.6 1.5	1" Swivel	1" Swivel
038	in cm	3.4 8.6	10.8 27.5	15.6 39.7	18.9 47.9	0.6 1.5	1" Swivel	1" Swivel
049	in cm	3.4 8.6	10.8 27.5	15.6 39.7	18.9 47.9	0.6 1.5	1" Swivel	1" Swivel
064	in cm	3.4 8.6	10.8 27.5	15.6 39.7	18.9 47.9	0.6 1.5	1" Swivel	1" Swivel
072	in cm	3.4 8.6	10.8 27.5	15.6 39.7	18.9 47.9	0.6 1.5	1" Swivel	1" Swivel

Horizontal Model		Electrical Knockouts		
		J 1/2"	K 1/2"	L 3/4"
		Low Voltage	External Pump	Power Supply
026	in cm	3.6 9.2	6.1 15.6	8.6 21.9
038	in cm	3.4 9.2	6.1 15.6	8.6 21.9
049	in cm	3.6 9.2	6.1 15.6	8.6 21.9
064	in cm	3.6 9.2	6.1 15.6	8.6 21.9
072	in cm	3.6 9.2	6.1 15.6	8.6 21.9

Condensate is 3/4" IPT.

Unit shipped with deluxe duct collar/filter rack extending from unit 3" [7.6cm] and is suitable for duct connection. Discharge flange and hanger brackets are factory installed.

## Dimensions — Horizontal GT-PX

Horizontal Model		Discharge Connection Duct Flange Installed (+/- 0.10 in, +/- 2.5mm)						Return Connection Standard Deluxe Filter Rack (+/- 0.10 in, +/- 2.5mm)			
		M Left Return	N	O Supply Width	P Supply Depth	Q Right Return	R	S Return Depth	T Return Height	U	V
026	in	3.6	2.0	12.5	15.5	3.6	2.0	33.8	16.2	2.3	1.5
	cm	9.3	5.1	31.8	39.4	9.2	5.2	85.8	41.0	5.8	3.9
038	in	3.1	1.2	19.0	17.5	3.1	1.0	34.8	18.2	3.1	1.5
	cm	8.0	3.1	48.3	44.5	8.0	2.6	88.3	46.1	7.8	3.9
049	in	3.1	1.2	19.0	17.5	3.1	1.0	39.8	18.2	3.1	1.5
	cm	8.0	3.1	48.3	44.5	8.0	2.6	101.0	46.1	7.8	3.9
064	in	3.1	1.2	19.0	17.5	3.1	1.0	44.8	18.2	3.1	1.5
	cm	8.0	3.1	48.3	44.5	8.0	2.6	113.7	46.1	7.8	3.9
072	in	3.1	1.2	19.0	17.5	3.1	1.0	44.8	18.2	3.1	1.5
	cm	8.0	3.1	48.3	44.5	8.0	2.6	113.7	46.1	7.8	3.9

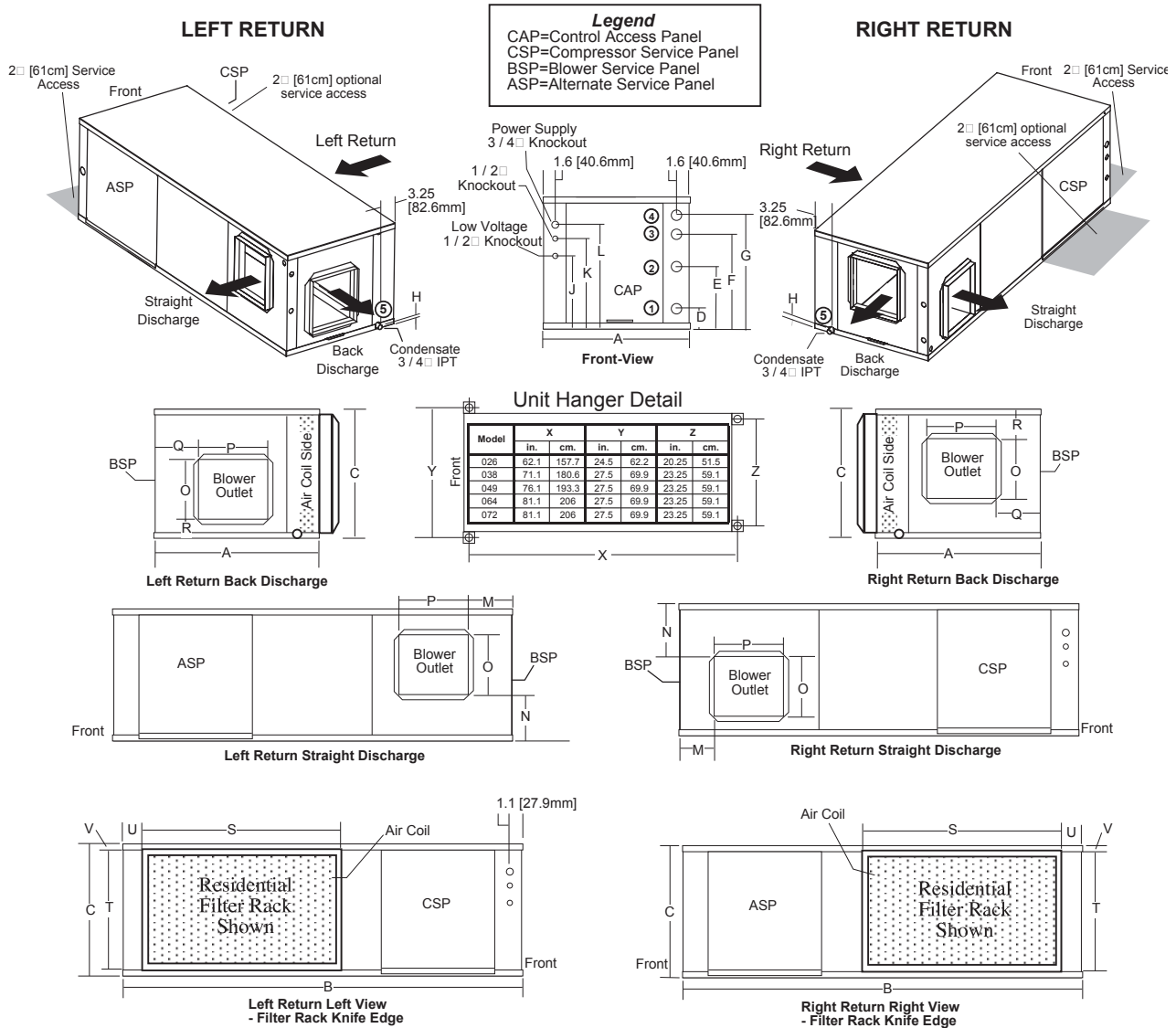

## Electrical Data

All GT-PX Units with ECM Fan Motor							GT-PX Units (ECM) Standard					GT-PX Units (ECM) with Whole House Dehumidification					
Model	Compressor			HWG Pump FLA	Ext Loop Pump FLA	Fan Motor FLA	Total Unit FLA	Min Circuit Amps	Max Fuse/HACR (2)	Supply Wire (2)		Whole House Dehumidification Pump FLA	Total Unit FLA	Min Circuit Amps	Max/Fuse HACR (2)	Supply Wire (2)	
	RLA	LRA	Qty							Min AWG 60°C (1, 4)	Max Length Ft (m) (3)					Min AWG 60°C (1, 4)	Max Length Ft (m) (3)
026	10.3	52.0	1	0.40	4.0	4.3	19.0	21.6	30	10	86 (26.2)	0.8	19.8	22.4	30	10	82 (25.2)
038	16.7	82.0	1	0.40	4.0	4.3	25.4	29.6	45	10	63 (19.1)	0.8	26.2	30.4	45	8	97 (29.6)
049	21.2	96.0	1	0.40	4.0	7.0	32.6	37.9	50	8	78 (23.8)	1.07	33.7	39.0	60	8	76 (23.1)
064	25.6	118.0	1	0.40	4.0	7.0	37.0	43.4	60	6	108 (32.9)	1.07	38.1	44.5	70	6	105 (32.1)
072	27.2	150.0	1	0.40	4.0	7.0	38.6	45.4	70	6	103 (31.4)	1.07	39.6	46.4	70	6	101 (30.8)

Rated Voltage of 208-230/60/1  
HACR circuit breaker in USA only

Min/Max Voltage of 197/254  
All fuses Class RK-5

**Notes:**

- (1) If wire is applied at ambient greater than 86°F (30°C), consult table 310-16 of the National Electrical Code (NEC). The ampacity of non-metallic sheathed cable (NM), otherwise known as Romex cable, shall be that of 60°C (140°F) conditions per the NEC Article 336-26. If other wiring is used, consult applicable tables of the NEC.
- (2) Current carrying capacity (amperes) of the wire used must not be less than the fuse/breaker size used.
- (3) Wire length based on one way measurement with 2% voltage drop.
- (4) Wire size based on 60°C copper conductor and Minimum Circuit Ampacity.

## GT-PX Electrical Wiring Diagram - 96B0005N37

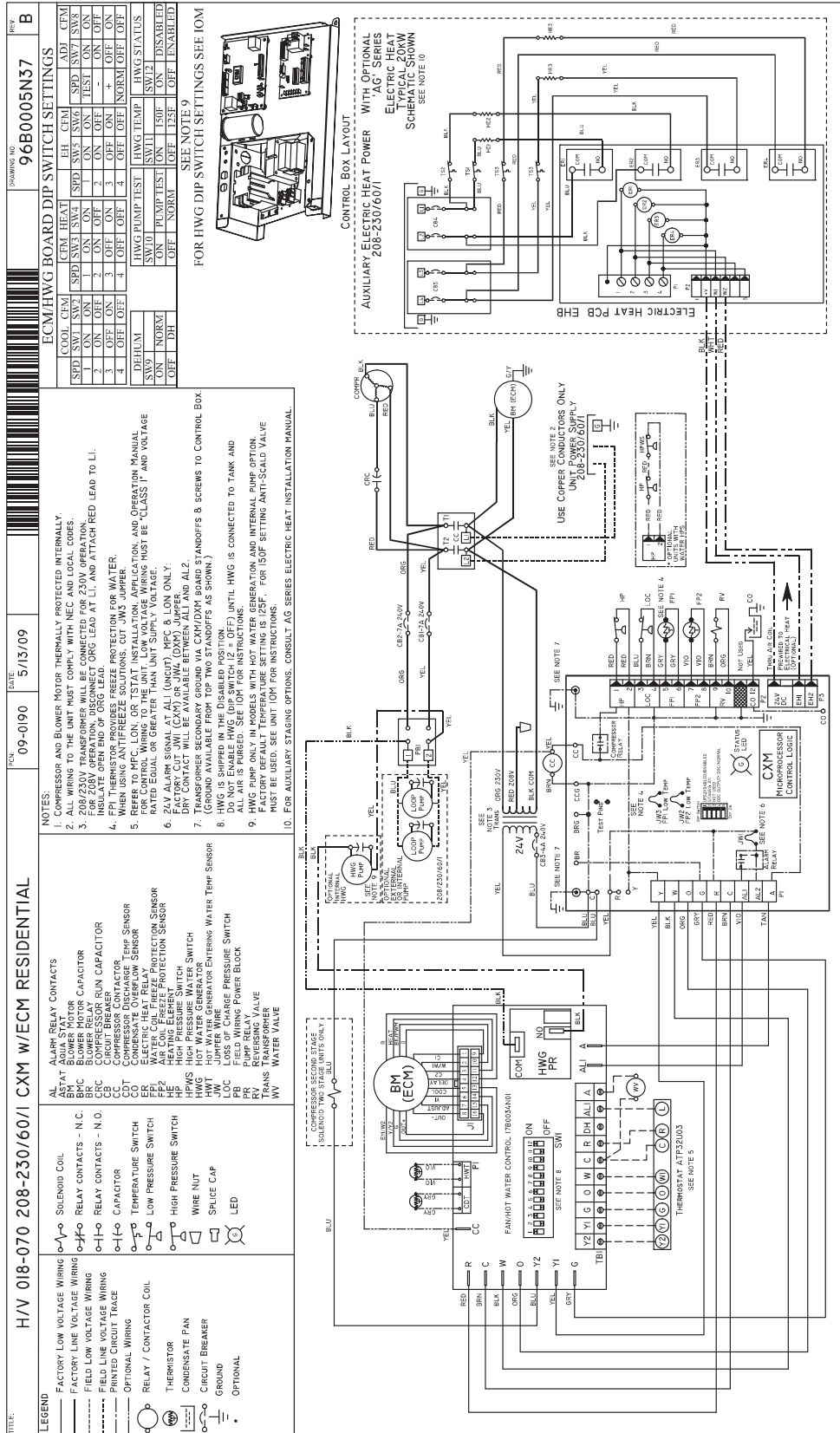

# GT-PX with Whole House Dehumidification™ Electrical Wiring Diagram - 96B0005N38

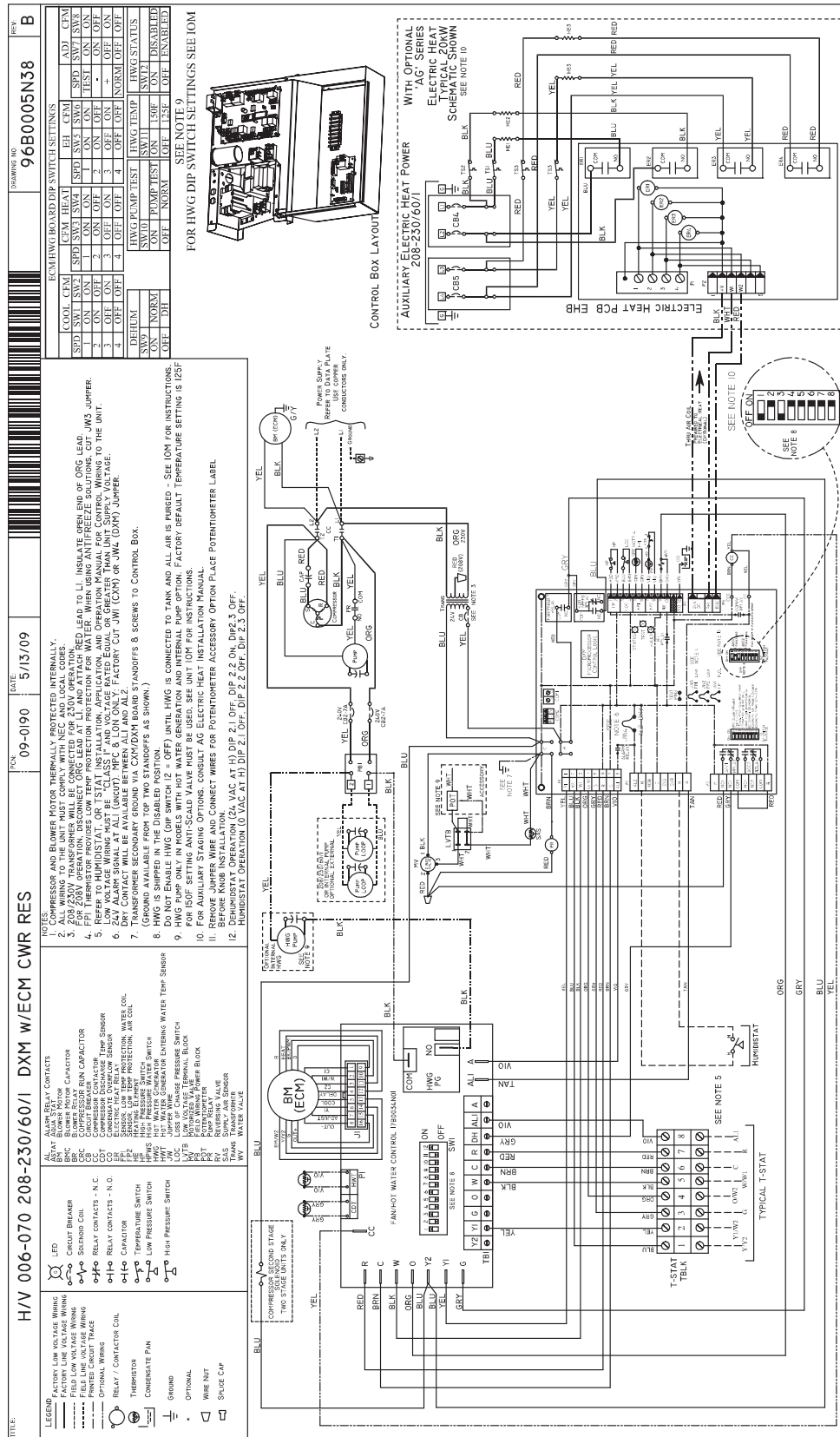



## GT-PX ECM Control Features

The ECM fan is controlled by an interface board that converts thermostat inputs and field selectable CFM settings to signals used by the ECM motor controller. Units manufactured before July 2005 have version I (P/N 69243707). Units manufactured between July 2005 and May 11, 2009 have version II (P/N 17B0019N01). Fan speeds are selected with jumpers for version I or via a nine position DIP switch for version II and III. To take full advantage of the ECM motor features, a multi-stage thermostat should be used (2-stage heat/2-stage cool or 3-stage heat/2-stage cool).

R410A packaged units built after May 11, 2009 have a ECM controllers version III (P/N 17B0034N01). This controller includes logic and a relay to control the HWG functions.

**Note:** Power must be off to the unit for at least three seconds before the ECM motor will recognize a speed change. The motor will recognize a change in the CFM Adjust or dehumidification mode settings while the unit is powered.

There are four different airflow settings from lowest airflow rate (speed tap 1) to the highest airflow rate (speed tap 4). The charts below indicate settings for both versions of the ECM interface board, followed by detailed information for each setting.

**Cooling Settings:** The cooling setting determines the cooling (normal) CFM for all units with ECM motor. Cooling (normal) setting is used when the unit is not in dehumidification mode. This setting also determines the heating CFM for GT-G (50YC) units. Tap 1 is the lowest CFM setting, while tap 4 is the highest CFM setting. To avoid air coil freeze-up, tap 1 may not be used if the dehumidification mode is selected. Consult submittal data or specifications catalog for the specific unit series and model to correlate speed tap setting to airflow in CFM.

**Heating Settings:** The heating setting determines the heating CFM for GT-PX (50YD) and GT-PG (50YE) units. This setting is not used for GT-G (50YC) units. Tap 1 is the lowest CFM setting, while tap 4 is the highest CFM setting. Consult submittal data or specifications catalog for the specific unit series and model to correlate speed tap setting to airflow in CFM.

**Auxiliary/Emergency Heat Settings:** The auxiliary/emergency heat setting determines the CFM when the unit is in auxiliary heat or emergency heat mode. This setting is used for residential units with internal electric heat. When auxiliary electric heat is energized (i.e. compressor and electric heat), the greater of the auxiliary/emergency or heating setting will be used. A “G” (fan) signal must be present from the thermostat

for electric heat to operate. Consult the submittal data or specifications catalog for the specific unit series and model to correlate speed tap setting to airflow in CFM.

**CFM Adjust Settings:** The CFM adjust setting allows four selections. The NORM setting is the factory default position. The + or – settings adjust the airflow by +/- 15%. The +/- settings are used to “fine tune” airflow adjustments. The TEST setting runs the ECM motor at 70% torque, which causes the motor to operate like a standard PSC motor, and disables the CFM counter.

**Dehumidification Mode Settings:** The dehumidification mode setting provides field selection of humidity control. When operating in the normal mode, the cooling airflow settings are determined by the cooling tap setting above. When dehumidification is enabled there is a reduction in airflow in cooling to increase the moisture removal of the heat pump. Consult submittal data or specifications catalog for the specific unit series and model to correlate speed tap to airflow in CFM. The dehumidification mode can be enabled in two ways.

1. **Constant Dehumidification Mode:** When the dehumidification mode is selected (via DIP switch or jumper setting), the ECM motor will operate with a multiplier applied to the cooling CFM settings (approx. 20-25% lower airflow). Any time the unit is running in the cooling mode, it will operate at the lower airflow to improve latent capacity. The “DEHUM” LED will be illuminated at all times. Heating airflow is not affected. NOTE: Do not select dehumidification mode if cooling setting is tap 1.
2. **Automatic (Humidistat-controlled) Dehumidification Mode:** When the dehumidification mode is selected (via DIP switch or jumper setting) AND a humidistat is connected to terminal DH (version II) or HUM (version I), the cooling airflow will only be reduced when the humidistat senses that additional dehumidification is required. The DH (or HUM) terminal is reverse logic. Therefore, a humidistat (not dehumidistat) is required. The “DEHUM” LED will be illuminated only when the humidistat is calling for dehumidification mode. Heating airflow is not affected. NOTE: Do not select dehumidification mode if cooling setting is tap 1.

## GT-PX ECM Control Features

### ECM Board Tap Settings

Cooling settings: GT-PX and GT-PG Units

Tap Setting	Version I 69243707	Version II 17B0019N01 Version III 17B0034N01	
	HP CFM Jumper	DIP Switch	
		SW1	SW2
1	1	ON	ON
2	2	ON	OFF
3	3	OFF	ON
4	4	OFF	OFF

Heating settings: GT-PG and GT-PG Units

Tap Setting	Version I 69243707	Version II 17B0019N01 Version III 17B0034N01	
	DELAY Jumper	DIP Switch	
		SW3	SW4
1	1	ON	ON
2	2	ON	OFF
3	3	OFF	ON
4	4	OFF	OFF

Aux/Emerg Heat settings: GT-PX and GT-PG Units

Tap Setting	Version I 69243707	Version II 17B0019N01 Version III 17B0034N01	
	AUX CFM Jumper	DIP Switch	
		SW5	SW6
1	1	ON	ON
2	2	ON	OFF
3	3	OFF	ON
4	4	OFF	OFF

CFM Adjust settings: GT-PX and GT-PG Units

Tap Setting	Version I 69243707	Version II 17B0019N01 Version III 17B0034N01	
	CFM Adj Jumper	DIP Switch	
		SW7	SW8
TEST	1	ON	ON
-	2	ON	OFF
+	3	OFF	ON
NORM	4	OFF	OFF

Dehum Mode settings: GT-PX and GT-PG Units

Tap Setting	Version I 69243707	Version II 17B0019N01 Version III 17B0034N01
	Dehumid Jumper	DIP Switch
		SW9
NORM	pins 1,2	ON
Dehumid	pins 2,3	OFF

### ECM Version II Interface Layout

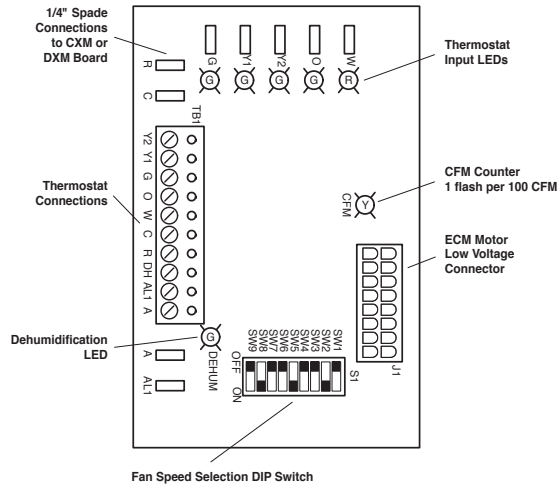

### ECM Version I Interface Layout

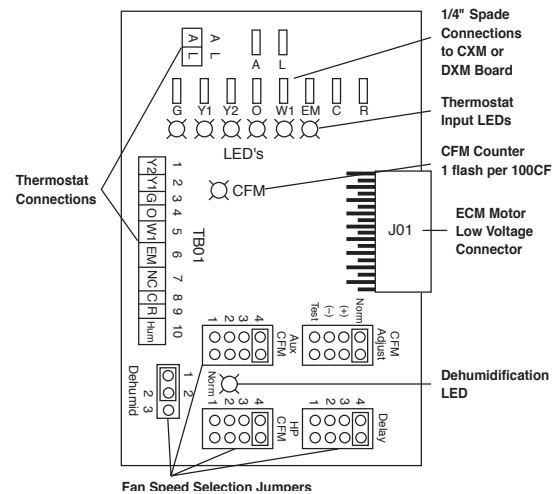

### ECM Version III Interface Layout

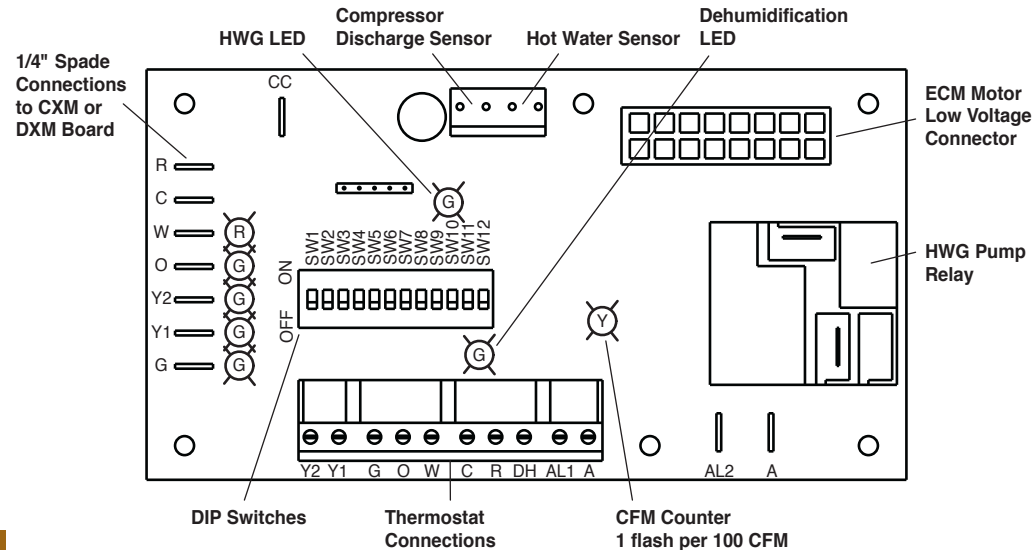

## Blower Performance Data

Airflow in CFM with wet coil and clean air filter

Model	Max ESP (in. wg)	Fan Motor (hp)	Tap Setting	Residential Units Only									AUX CFM	Aux/ Emerg Mode
				Cooling Mode			Dehumid Mode			Heating Mode				
				Stg 1	Stg 2	Fan	Stg 1	Stg 2	Fan	Stg 1	Stg 2	Fan		
026	0.50	1/2	4	810	950	475	630	740	475	920	1060	475	4	1060
	0.50	1/2	3	725	850	425	560	660	425	825	950	425	3	950
	0.50	1/2	2	620	730	370	490	570	370	710	820	370	2	820
	0.50	1/2	1	520	610	300				600	690	300	1	690
038	0.50	1/2	4	1120	1400	700	870	1090	700	1120	1400	700	4	1400
	0.50	1/2	3	1000	1250	630	780	980	630	1000	1250	630	3	1350
	0.50	1/2	2	860	1080	540	670	840	540	860	1080	540	2	1350
	0.50	1/2	1	730	900	450				730	900	450	1	1350
049	0.75	1	4	1460	1730	870	1140	1350	870	1560	1850	870	4	1850
	0.75	1	3	1300	1550	780	1020	1210	780	1400	1650	780	3	1660
	0.75	1	2	1120	1330	670	870	1040	670	1200	1430	670	2	1430
	0.75	1	1	940	1120	560				1010	1200	560	1	1350
064	0.75	1	4	1670	2050	1020	1300	1600	1020	1860	2280	1020	4	2280
	0.75	1	3	1500	1825	920	1160	1430	920	1650	2050	920	3	2040
	0.75	1	2	1280	1580	790	1000	1230	790	1430	1750	790	2	1750
	0.75	1	1	1080	1320	660				1200	1470	660	1	1470
072	0.75	1	4	1620	2190	1050	1270	1650	1050	1690	2230	1050	4	2230
	0.75	1	3	1500	1950	980	1170	1520	980	1600	2100	980	3	2100
	0.75	1	2	1400	1830	910	1100	1420	910	1400	1850	910	2	1870
	0.75	1	1	1320	1700	850				1240	1620	850	1	1670

Factory shipped on Tap Setting 2

During Auxiliary operation (residential units only) the CFM will run at the higher if the heating (delay jumper) or AUX settings

Airflow is controlled within +/- 5% up to Max ESP shown with wet coil and standard 1" fiberglass filter

Do not select Dehumidification mode if HP CFM is on setting 1

All units ARI/ISO/ASHRAE 13256-1 rated HP (Cooling) Delay (Heating) CFM Setting 3

## Auxiliary Electric Heat

### Auxiliary Heat Ratings

Auxiliary Electric Heat Model	GT-PX					kW Rating		Btuh Rating		Minimum CFM Required
	026	038	049	064	072	230V	208V	230V	208V	
AGM5A						4.8	3.6	16300	12300	500
AGM8A						7.6	5.7	25900	19400	650
AGM10A						9.6	7.2	32700	24600	650
AGM12A						11.4	8.6	38900	29200	750
AGL10A						9.6	7.2	32700	24600	1300
AGL15A						14.4	10.8	49100	36900	1350
AGL20A						19.2	14.4	65500	49200	1350

Grey area denotes compatibility

Note: Horizontal units rated for zero clearance unit and 1" clearance for the first three feet of duct, vertical units rated for zero clearance for both unit and duct.

### Auxiliary Heat Electrical Data

Auxiliary Electric Heat Model	Supply Circuit	Heater Amps		Minimum Circuit Amps		Maximum Fuse		Supply Wire	
		230V	208V	230V	208V	230V	208V	Min AWG	Max Ft
AGM5A	Single	20.0	17.3	25.0	21.6	25	25	10	70
AGM8A	Single	31.7	27.5	39.6	34.4	40	35	8	70
AGM10A	Single	40.0	34.7	50.0	43.4	50	45	6	90
AGM12A	Single	47.5	41.2	59.4	51.5	60	60	6	70
	Dual - L1/L2	31.7	27.5	39.6	34.4	40	35	8	70
	Dual - L3/L4	15.8	13.7	19.8	17.1	20	20	12	50
AGL10A	Single	40.0	34.7	50.0	43.4	50	45	6	80
AGL15A	Single	60.0	52.0	75.0	65.0	80	70	6	50
	Dual - L1/L2	40.0	34.7	50.0	43.4	50	45	6	80
	Dual - L3/L4	20.0	17.3	25.0	21.6	25	25	10	70
AGL20A	Single	80.0	69.3	100.0	86.6	100	90	2	100
	Dual - L1/L2	40.0	34.7	50.0	43.4	50	45	6	80
	Dual - L3/L4	40.0	34.7	50.0	43.4	50	45	6	80

All heaters rated single phase 208-230V 60Hz  
 Wire size based on 60°C (90°C) copper conductor  
 All models 12kW or larger feature internal circuit breakers

Wire length based on one way measurement with 2% voltage drop  
 Part numbers with "H" included are for horizontal units only  
 All Fuses UL Class K general purpose

## Engineering Guide Specifications

**General**

The water source heating/cooling units shall be vertical upflow air discharge. Units shall be ARI/ISO/ASHRAE 13256-1 (ground-source closed-loop) performance certified and listed by a nationally recognized safety-testing laboratory or agency. Each unit shall be water run-tested at the factory. Each unit shall be pallet mounted and shipped with appropriate protective packaging to help avoid damage in transportation. The units shall be warranted by the manufacturer against defects in materials and workmanship for a period of five years on all parts, and ten years on the compressor and refrigerant circuit parts with a service labor allowance during the first 30 days. An optional extended warranty is available for the GT-PX Series units, which adds a labor allowance and trip charge. The water source units shall be designed to operate with entering fluid temperature between 20°F and 120°F.

**Casing & Cabinet**

The cabinet shall be fabricated from heavy-gauge galvanized steel and painted with an epoxy powder coating. The interior shall be insulated with 1/2" thick, multi-density, coated glass fiber. Insulation in the air handler section shall be foil backed for ease of cleaning. Two (vertical), one (horizontal) blower compartment and three compressor compartment access panels shall be provided and shall be removable with supply and return ductwork in place. The internal component layout shall provide for major service with the unit in-place for restricted access installations.

A duct collar (Field installed) shall be provided on the supply air opening. 2" high efficiency MERV 11 pleated filters shall be provided with each unit. Units shall have filter frames. The units shall have an insulated divider panel between the air handling section and the compressor section to minimize the transmission of compressor noise, and to permit operational service testing without air bypass. Units shall be supplied with left or right air inlet.

**Refrigerant Circuit**

All units shall contain Puron® (HFC 410A) sealed refrigerant circuit employing a hermetic motor-compressor; bidirectional thermal expansion valve, finned tube air-to-refrigerant heat exchanger; reversing valve, coaxial tube water-to-refrigerant heat exchanger and service ports. An optional Hot Water Generator (desuperheater) coil shall be provided.

Compressors shall be Copeland UltraTech™ Two-Stage scroll type designed for heat pump duty and mounted on spring vibration isolators. Compressor motors shall be single phase PSC with internal overload protection. A factory installed bidirectional filter drier shall be provided on all models. The finned tube coil shall be sized for low-face velocity and constructed of lanced aluminum fins bonded to rifled copper tubes in a staggered pattern not less than three rows deep. Entire air coil surface shall be e-coated for corrosion protection.

The coaxial water-to-refrigerant heat exchangers shall be designed for close approach temperatures and be constructed of a convoluted copper (optional cupronickel) inner tube and a steel outer tube. The thermal expansion valves shall provide proper superheat over the entire fluid temperature range with minimal "hunting". The valve shall operate bi-directionally without the use of check valves.

The water-to-refrigerant heat exchanger and refrigerant suction lines shall be insulated to prevent condensation at low liquid temperatures.

**Fan Motor and Blower**

The fan shall be a direct drive centrifugal type with a dynamically balanced wheel. The housing and wheel shall be designed for quiet low outlet velocity operation and of galvanized steel construction. Tight fan housing geometry shall not be permitted. The fan housing shall be removable from the unit without disconnecting the supply air ductwork for servicing of the fan motor. The fan motor shall be an ECM variable speed type. The ECM fan motor shall provide soft starting, maintain constant CFM over its static operating range and provide airflow adjustment on its control board. The fan motor shall be isolated from the housing by rubber grommets. The motor shall be permanently lubricated and have thermal overload protection.

**Electrical**

CXM Control - A microprocessor-based compressor controller shall be provided to monitor and control unit operation. The control shall provide compressor and electric heater sequencing, high and low pressure monitoring, field selectable water and air coil freeze protection sensing, condensate overflow sensing, over/under voltage monitoring, and unit performance sentinel (UPS). The control shall also provide for water valve connection, a test mode, short cycle protection, random start-up, as well as fault LED, fault memory, and intelligent fault retry.

The control shall employ quick attach harness assemblies for low voltage connections to the control board to aid in troubleshooting or replacement. An integral terminal block with screw terminals shall be provided on the control for all field low voltage connections. A circuit breaker protected 75VA transformer shall be employed. Line voltage box lugs shall be provided for unit wiring. Units shall have knockouts for entrance of low and line voltage wiring. The fan motor and control box shall be harness plug-connected for easy removal.

Residential models shall have a dual circuit-breaker protected power block for the connection of external flow controller pump module.

**Piping**

Supply and return water connections, as well as Hot Water Generator (desuperheater) connections shall be 1" IPT (Internal Pipe Thread) brass swivel fittings which provide a union and eliminate the need for pipe wrenches and sealants when making field connections. A thread by sweat fitting shall be provided for connection to the water heater. All water piping shall be insulated to prevent condensation at low liquid temperatures.

The condensate connection shall be a 3/4" PVC glue (socket) with internal-trap (Vertical Models).

## Accessories & Warranty

### Accessories & Options

#### **Whole House Dehumidification**

An optional internal whole house dehumidifier shall be factory installed, which allows the unit to operate in one of three modes, heating, cooling, or dehumidification. Operation must include modulating controls to provide neutral air (72°F) regardless of entering water temperature. Requires ATP32U04 thermostat or separate humidistat. See the Whole House Dehumidification Installation Guide/Application Manual for more details and unit availability.

#### **Hot Water Generator**

An optional insulated heat reclaiming desuperheater coil of vented double-wall copper construction suitable for potable water shall be provided. The coil and hot water circulating pump shall be factory mounted inside the unit. A high limit and low compressor discharge line temperature switch shall be provided to disable the pump when these conditions occur.

#### **Cupro-Nickel Heat Exchanger**

An optional corrosion resistant CuNi coaxial heat exchanger shall be factory installed in lieu of standard copper construction.

#### **Thermostat (field installed)**

A multistage auto-changeover electronic digital thermostat shall be provided. The thermostat shall offer 3 heating and 2 cooling stages with precise temperature control. An OFF-HEAT-AUTO-COOL-EMERG system switch, OFF-AUTO fan switch, and indicating LED's shall be provided. The thermostat shall read out in °F or °C. An optional remote indoor sensor and outdoor sensor use shall be available on some models.

#### **Flow Controller (field installed)**

A self-contained module shall provide all fluid pumping, fill and connection requirements for ground-source closed-loop systems up to 20 GPM. The Flow Controller shall provide 1" pump isolation valves and 3-way service valves. Pump heads shall be removable from the volute for easy replacement. The Flow Controller shall be enclosed in a polystyrene case and fully insulated with urethane foam to prevent condensation. The Flow Controller shall have a 5-year warranty on all parts.

#### **Auxiliary Heater (field installed)**

An internal, field-installed electric heater shall provide supplemental and/or emergency heating capability when used with the three stage heating thermostat. (Heater is externally mounted on horizontal units).

#### **Hose Connection Kit (field installed)**

An accessory hose kit shall provide 150psi 1" rubber hose with brass fittings equipped with service pressure/temperature ports for connection between the unit and Flow Controller.

### Warranty Information

Carrier Geothermal GT-PX Series residential warranty reflects the reliability built in to every unit and includes five years on all parts, and ten years on the compressor and refrigerant circuit parts with a service labor allowance during the first 30 days. An optional extended warranty is available for the GT-PX Series units, which adds a labor allowance and trip charge. See extended warranty certificate (CA186) for details.



# Revision History

Date	Page #	Description
02 June, 09	All	Removed R22 Units and Related Data
01 Jan, 09	All	Reformatted Document Size
03 Mar, 08	37	Updated Specifications
03 Mar, 08	26	Updated Downflow Dimensional Data
01 Mar, 07	30	Added New Notes to Electrical Data
01 Mar, 07	All	Added Model 072 Information
01 Oct, 06	All	First Published