

SINGER MODEL 106/206-F-Type 5

Non-Modulating Float Valve Schematic A-0421C
Installation, Operating and Maintenance Instructions

DESCRIPTION:

106/206-F-5 is a pilot operated float valve for applications requiring the valve to open and close at predetermined high and low levels. Valve action is on-off with no intermediate throttling positions.

Main Valve (1) is installed in the line going directly into the base or top of the tank. Float Pilot (5) is a three-way valve which controls the flow into or out of the Main Valve bonnet. Speed Control Valve (4) provides opening and closing speed adjustment.

DESCRIPTION OF OPERATION:

Main Valve (1) is normally open when pressure is applied to the valve inlet. When this same pressure is applied to the bonnet, the valve closes tight because the area of the diaphragm is greater than the area of the seat. Pressure above the diaphragm determines the position of the Main Valve.

Bonnet pressure is controlled by Float Pilot (5).

Float Pilot (5) is operated directly by a float riding on the liquid surface. The float moves freely up and down on a rod, switching Pilot (5) only when it contacts the stops fastened to the rod. Line pressure is directed into the Main Valve bonnet to close and exhausted to open.

Unless otherwise specified, this valve will be assembled for service temperatures to 140° F. Higher temperature ratings are available.

INSTALLATION:

Pilot Valve:

Take care when installing Float Pilot (5) to avoid damage. If it is necessary to remove any fittings, make sure they are kept clean and replaced correctly.

Install Float Pilot (5) in a convenient location. The connecting piping between the Main Valve and Pilot (5) should be at least 1/4" pipe or equivalent tubing. Brass pipe or copper tubing is recommended. See Schematic A-0421C for connections. Be sure the float rod is absolutely vertical. Pilot Lever Arm and Counterweight Lever Arm must be parallel, so that float rod remains vertical throughout full movement of Pilot linkage.

NOTE - IMPORTANT: Counterweight should be adjusted into such a position, that the float rod is perfectly balanced and the Pilot will stay in any position. To check this, hold the float off the stops and move the linkage slowly through the full travel. It should stay in any position without any tendency to move on its own.

ADJUSTMENT PROCEDURE:

1. Check setting of Speed Control (4); it should be initially set at one turn open.
2. Adjust upper and lower Adjustable Stops at desired shut off and open positions.
3. Open Isolating Valve (2) and manually operate Float Pilot (5), observing action on valve indicator or liquid level change.
4. Raise and lower level several times to cause valve to operate. Adjust Speed Control (4) to give a closing speed that does not cause any closing surges. Do not close Speed Control tight as this will cause Main Valve to be inoperative.

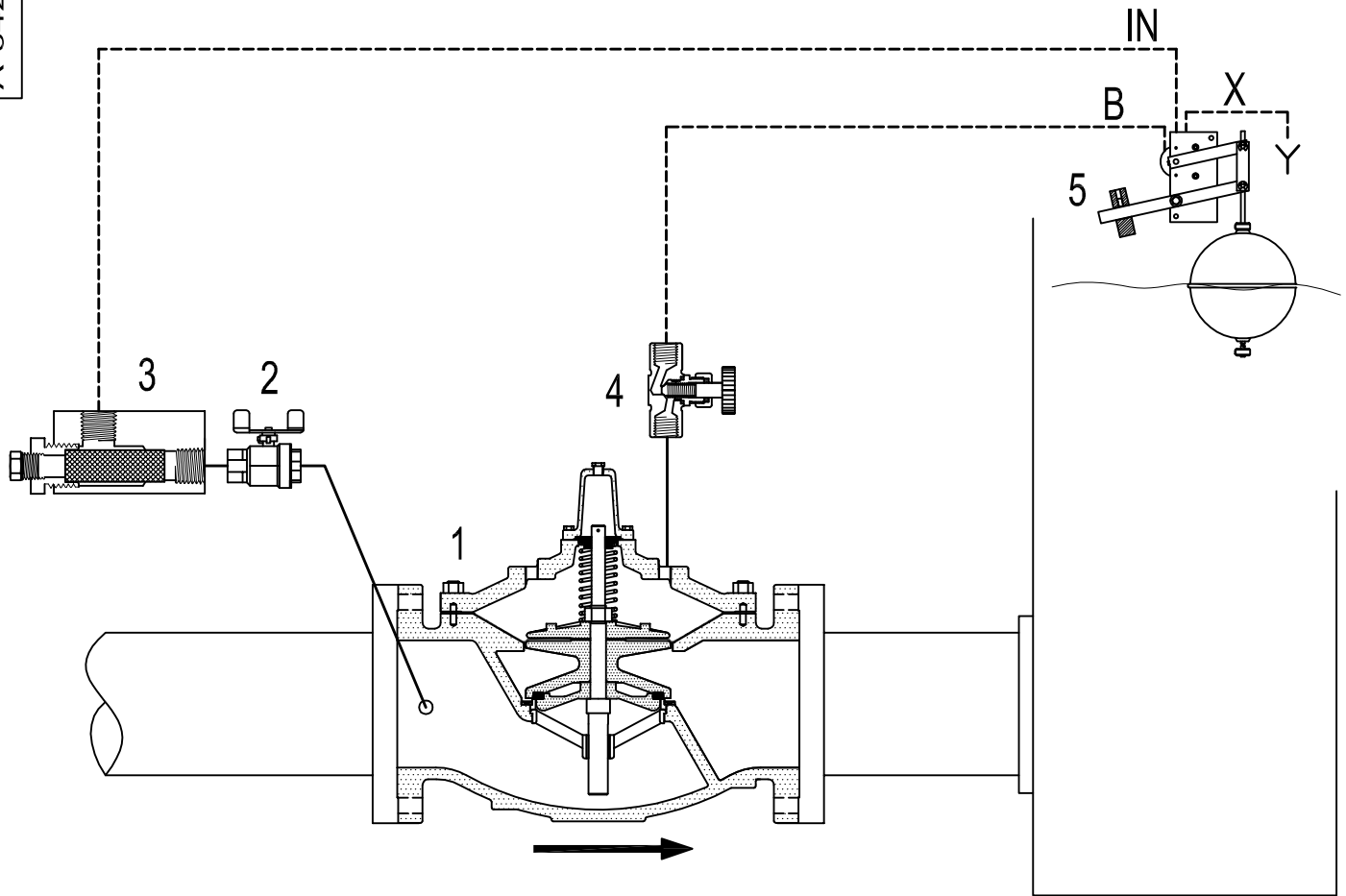

- 1. Main Valve - Singer Model 106/206-PG.
- 2. Isolating Valve.
- 3. Strainer - 40 mesh - J0098A.
- 4. Speed Control Valve - Model 852-B.
- 5. Float Pilot - Model 43 (ON-OFF with differential control).

----- connected in field

Non-Modulating Float Valve with Differential Control.

 SINGER VALVE <i>Result-Based Solutions. Globally.</i>	
www.singervalve.com 12850-87th Avenue, Surrey, B.C. V3W 3H9	
Drawn By:	Approved By:
Kari Oksanen	Kari Oksanen
Date:	Drawing:
January 30, 2013	A-0421C
Model 106 or 206-F-Type 5	