

## **SINGER MODEL 106/206-2SC-PCO**

### **Dual Solenoid Control Valve**

### **Schematic A-7637A**

#### **DESCRIPTION:**

Model 106/206-2SC-PCO is a valve positioned by intermittent operation of Solenoid Valves (5) and (6). It is normally operated by a programmable process controller. The process controller is not included with the standard valve.

#### **DESCRIPTION OF OPERATION**

Main Valve (1) closes when the inlet pressure is directed to the bonnet (above the diaphragm) and opens when the bonnet is vented to the downstream. Refer to 106/206 PG "Description of Operation".

Solenoid Valves (5) and (6) are normally closed. When both solenoids are de-energized, Main Valve (1) remains in position. Energizing Solenoid Valve (5) closes the valve. Energizing Solenoid Valve (6) opens the valve.

Solenoids Valves (5) and (6) are normally equipped with 120 VAC coils. 12 or 24 Volt DC coils that can be driven by DC logic (SSR DRIVE) outputs from a process controller are available.

#### **MANUAL-BY-PASS**

The pilot system is equipped with By-pass Valves (7) and (8) so that the Main Valve can be opened or closed without electricity. To close the Main Valve manually, By-pass Valve (7) should be opened while By-pass Valve (8) is closed. Reversing this operation will open the Main Valve.

#### **INSTALLATION:**

1. Refer to 106/206-PG "Installation".
2. Check Solenoid Valves (5) and (6) for correct voltage and operation.
3. Wire Solenoid Valves (5) and (6) to the controller as required.
4. Pressurize the valve slowly and bleed air from the bonnet of the Main Valve. See 106/206-PG Instructions.

#### **ADJUSTING PROCEDURE:**

This valve is normally operated by pulsing Solenoid Valve (5) or (6) to position the Main Valve as required. This means that the Main Valve moves in a step fashion. Size of these steps is determined by the length of the pulse (time of energization) and the setting of Speed Controls (4) and (9).

Adjust pulse width and Speed Control settings to get required control.

#### **SERVICE SUGGESTIONS:**

1. See service suggestions for 106/206-PG Main Valve and Solenoid Valve.
2. **Never energize the solenoid coil when the coil is removed from the Solenoid Valve.**
3. If the Main Valve fails to close, the inlet pressure is not connected to the bonnet because:
  - Isolating Valve (2A) or (2B) is closed.
  - Strainer (3) is plugged.
  - Closing Speed Control (4) is closed.
  - Solenoid Valve (5) is de-energized or faulty.
  - By-pass Valve (8) is open.
  - Main Valve diaphragm is ruptured.
  - An obstruction in the Main Valve seat is preventing closure.

If the Main Valve does not open, pressure is not being relieved from the bonnet because:

- Solenoid Valve (6) is not energized or is faulty.
- Opening Speed Control (9) is closed.
- Isolating Valve (2B) or (2C) is closed.
- There is not sufficient pressure drop available to open the Main Valve.

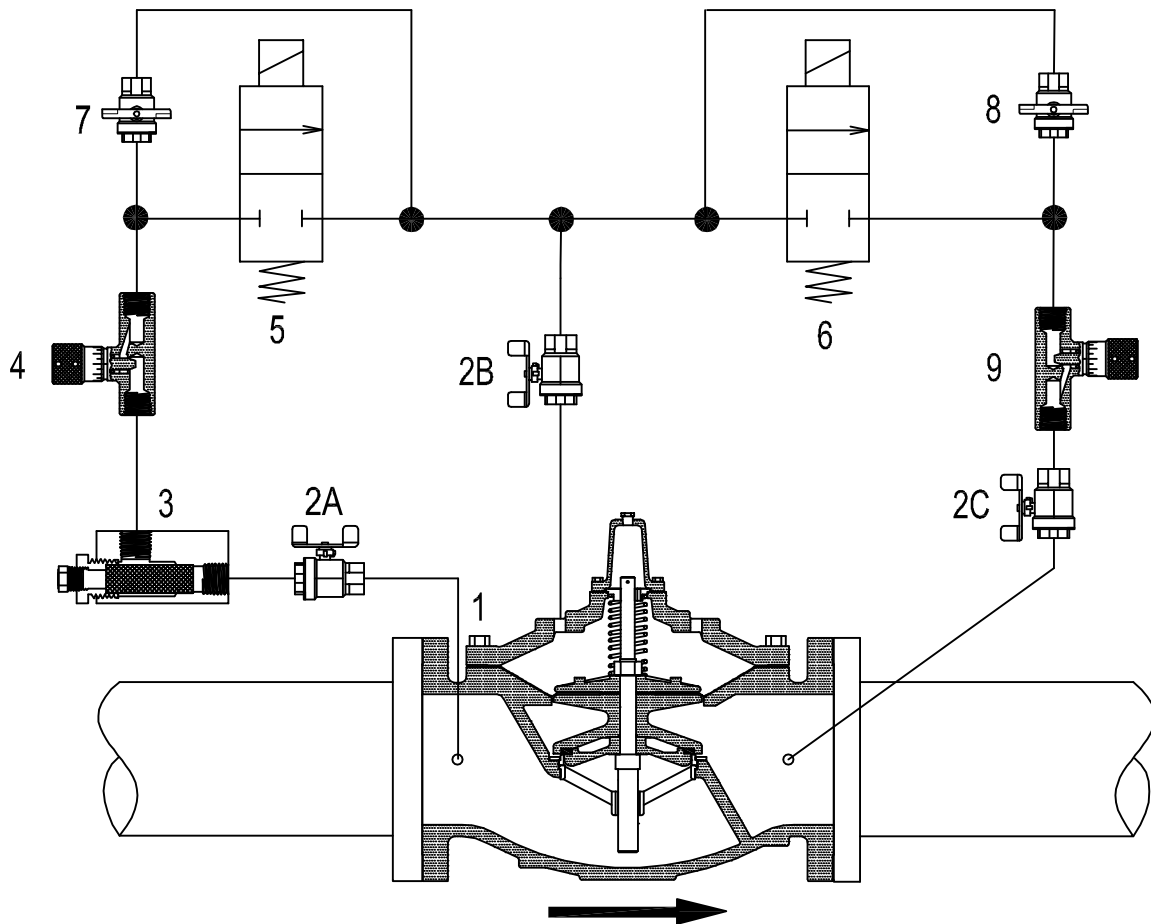

1. Main Valve - Model 106/206-PG.
2. Isolating Valves - A,B,C - J0044A.
3. Strainer - 40 mesh - J0098A.
4. Closing Speed Control - Model J0074.
5. Solenoid Valve - NC, 120VAC - CLOSING.
6. Solenoid Valve - NC, 120VAC - OPENING.
7. By-pass Valve - Closing - J0044A.
8. By-pass Valve - Opening - J0044A.
9. Opening Speed Control - Model J0074.

Dual Solenoid Control Valve  
suitable for interfacing with  
electronic programmable controller.

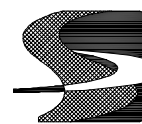

# SINGER VALVE

*Result-Based Solutions. Globally.*

[www.singervalve.com](http://www.singervalve.com) 12850-87th Avenue, Surrey, B.C. V3W 3H9

Drawn By:

**Scott Grover**

Approved By:

**Kari Oksanen**

Date:

**October 4, 1999**

Drawing:

**A-7637A**

**106/206-2SC-PCO**