

TY UserGuide

For standard TY models



TellerMate *Maximize your profit*



Contents

Introduction

Guidelines	3
What you get	4
Installation	5
Connectivity and Printer	6
What you can count with your TY	7

Display and Buttons	8
----------------------------------	----------

Counting

Getting started	9
Tasks / Reference Numbers	
Bills	10
Loose- / strapped- / clipped - bills	
Coupons	
Coins	12
Rolls and full rolls	
Cups / Scoop	

User Menu	14
------------------------	-----------

- AutoAdd
- AutoScroll
- Options

Calibration	17
--------------------------	-----------

Using the keypad	18
-------------------------------	-----------

- Non-cash items
- Keying in a denomination
- Calculator

FAQs	19
-------------------	-----------

Technical specification	20
--------------------------------------	-----------

Tellermate TY is the leading cash management solution for your business enabling you to quickly and efficiently count and manage your cash.

Stand-alone or connected directly to business reporting systems, TY helps to increase the efficiency, security and accuracy of a wide range of cash management tasks.

This user guide is for TY retail models: 100 - 350.

TY counts all money such as those contained in a typical cash drawer:

- Bills (loose, strapped and clipped bills)
- Coins (loose and rolls)
- Non-cash items (checks, credit card values, etc.)

TY comes with optional connections to printer and PC systems. This document includes instructions on how to get started with your TY and on how to configure the system to suit your preferences. (Please be aware that since there is a range of TY models, not all features illustrated in this document may be present in the model that you purchased).

General Guidelines

1. Only sorted money can be counted. Make sure that no denominations are mixed. This machine is not a sorting machine.
2. Put only the denomination on the hod which is shown on the display.
3. This machine is not a counterfeit detector and therefore cannot detect if money is counterfeit.

Technical Guidelines

1. Set the Tellermate TY on a flat stable surface that is free from vibration and drafts (such as air conditioning). Do not place this product on an unstable cart, stand or table. The product may fall causing damage to the product or injury to the user.
2. Use only the power adaptor supplied at the specified supply voltage. Do not use any other power adaptor. Do not use a damaged or wet power adaptor. Do not connect the power adaptor with wet hands.
3. Do not subject the equipment to a strong impact or shock load by hitting or dropping it. Ensure that money is placed onto the equipment with reasonable care. Treat it with respect.
4. Do not install or use the equipment in a manner that will apply force to the cables.
5. Do not clean the machine with wet or damp products. Only with a dry cloth. Do not spill any liquid, spray or chemicals over the equipment. If any liquid is spilled on it, disconnect the power cable from the supply, remove battery and contact your dealer.
6. Do not leave any objects on the hod when not in use, not even the cups or scoop.
7. Do not disassemble. Your warranty claim will expire immediately.

What you get



Standard items

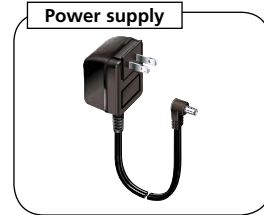
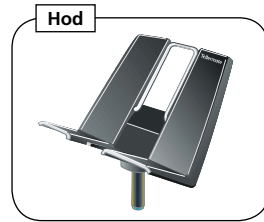

Optional extras

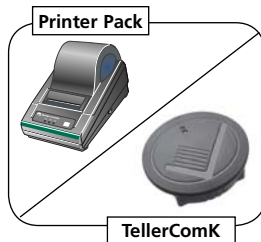
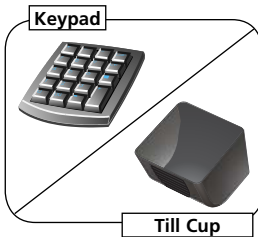

Information about the Keypad: please see page 18
Information about the Printer: please see page 6 and 15

If you require any further information about the optional items please contact your nearest Tellermate dealer.

Connecting your equipment

Hod

Insert the hod firmly into the TY until you feel a slight resistance.

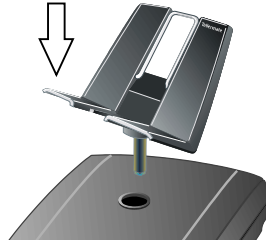

Power Supply

Insert one end of the TY power supply into the back of the Tellermate and the other end into an electrical outlet.

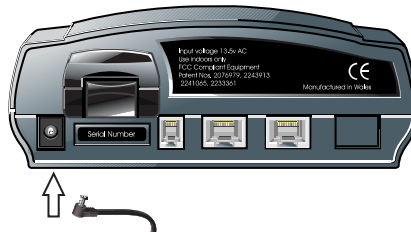

LEDs



Green light:
The TY is on and the battery, if fitted, is charged.



Red light:
The TY is on and the battery is charging.



Connectivity and Printer



Connecting to a PC/TellerComK *optional*

Insert one end of the communication cable into the back of the TY in Port 1 and the other into the PC.

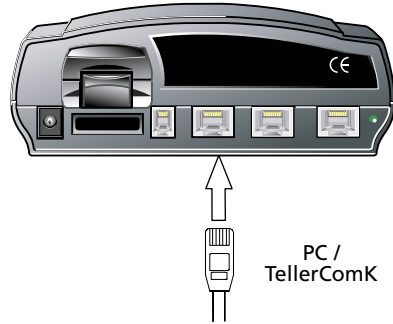

Connecting to a printer *optional*

Insert the printer cable into the middle port. Insert the other end of the printer cable into the printer. Plug in the printer power supply to the printer. Then turn the printer on using the power switch located on the printer.

*Note: Location of printer port may differ depending on model.

Please see page 15 how to enable the printer in the menu

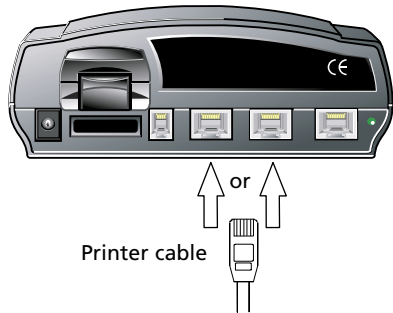

Connecting to USB or Ethernet *optional*

Insert one end of the USB or Ethernet cable into the back of the TY in Port 3 and the other into the PC or network.

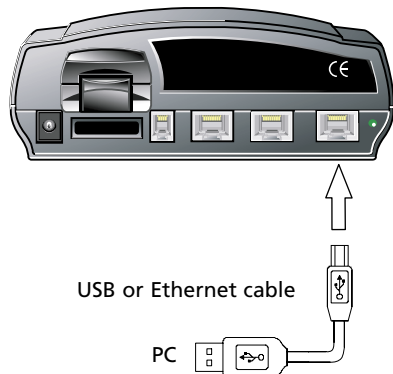

*Note: Port 3 can only be one of the above options.



Money wraps

WRAP - this is a term used by Tellermate to describe the different ways in which money is packaged. Wrap type options will differ according to TY model. Wrap types available for your model are shown using the WRAP key.

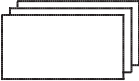
Bills

	<p>Loose & strapped bills - for counting your loose and strapped bills of the selected denomination. Loose bills are counted by adding 15-20 bills onto the hod at any one time. This stacking process is repeated until all the bills have been counted. Bundles have to be strapped together in a fixed quantity. A typical bundle quantity is 100 bills. Each bundle has to be placed on the hod one on top of another.</p> <p style="text-align: right;">See also page 10</p>
	<p>Clipped bills - for counting bills of the selected denomination that are clipped together in a fixed quantity. A typical clip quantity is 10 or 20 bills.</p> <p style="text-align: right;">See also page 11</p>

Coins

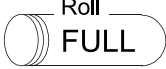
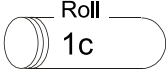
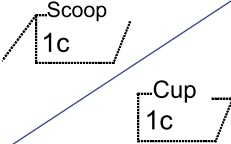
	<p>Full roll - for checking full standard rolls of ANY denomination. Rolls can be added one by one, without removing, and in any denomination.</p> <p style="text-align: right;">See also page 12</p>
	<p>Rolled coins - for counting coins of the same selected denomination. Rolls can be counted even if only partly full.</p> <p style="text-align: right;">See also page 13</p>
	<p>Scoop of loose coins - for counting loose coin, of the same selected denomination.</p> <p>Cup of loose coins - for counting loose coin from a cash drawer, of the same selected denomination.</p> <p style="text-align: right;">See also page 13</p>

Display & Buttons



ON, OFF 	Press to turn the TY on, hold down to turn the TY off	CE 	CE: Clear current denomination
\$ 	Switch between two currencies	END 	End: End count / return to previous display
MENU 	Enter Menu to customize TY	COINS 	Select coins
ENTER 	Enter data or accept highlighted option	BILLS 	Select bills / scroll through menus
WRAP 	Select container / wrap type		
+ 	Manual add (Banking models)	BANK 	Bank (Retail models): Start Bank



Your front panel may vary from the illustration above depending on TY model.

Starting

Switching On

Press the red ON.OFF button.

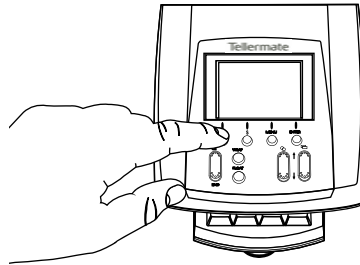

Tasks

Your TY software may come with pre-programmed tasks to help you process your money.

- To select a task press the blue BILLS key.
- To accept the task press the green ENTER key.

(Please note that not all models will have the same pre-programmed tasks and that task names are country specific).

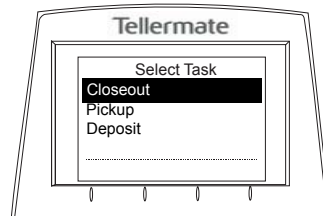

Reference Numbers

Your TY software may come with pre-programmed reference numbers (for registers, cashiers, stores, etc.).

- To enter your reference numbers use the keypad under the TY.
- Key in the number and accept it by pressing the PLUS (+) key.
- When there is no key-pad then enter the numbers by pressing MENU (+) or \$ (-).
- If you make a mistake press the CE key to clear the entry.

(Please note that not all models will have reference numbers).

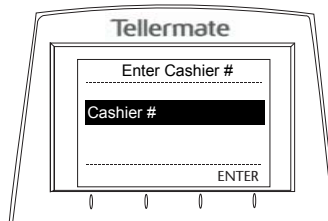

Counting - Bills



Counting loose and strapped bills

Count one denomination at a time.

Use the **BILLS** key to select the denomination.

Stack the bills against the short side of the hod.

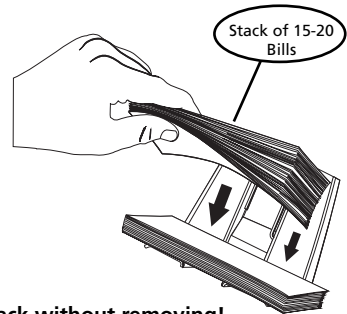

Stack without removing!

- Stack in batches of **15-20 bills at a time without removing them when placed.** The TY beeps to confirm the money has been placed on the hod.
- Leave the first stack** on the hod and add the next stack of the same denomination. When finished with a denomination remove all bills at one time. The TY beeps to confirm the money has been counted and added to the total.

Wrap type for loose and strapped bills

\$ 5	
X20	\$ 100
Deposit	0.00

<p>LIFT ABOUT HALF the bills added then put them back</p>	
Total	0.50

- '**LIFT ABOUT HALF**' appears on your display if you have added too many bills at once. Remove half the bills from the hod. The TY will beep and the lifted bills can be added.

- Strapped bills bundles** (e.g. 50 or 100 bills) of the same denomination can also be counted in this mode without removing the band. Simply place the strapped bills onto the hod **one after the other**. The hod will hold up to 4-5 bundles.

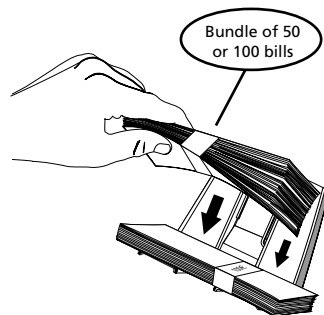

<p>REMOVE STRAP And count in batches of 15-20</p>	
Total	0.00

- If '**SUSPECT STRAP**' appears, remove the strap and count loose as described above.

Counting clipped bills

- Use the **BILLS** key to select the denomination.
- Press the **WRAP** key to select clip mode.
- Put the first clipped bundle on the hod. When the value is displayed, more clipped bills may be added.
- If **'REMOVE CLIP'** appears take all the bills off the hod, press the **WRAP** key to select loose count mode and count in stacks of 15-20 (see page 10).

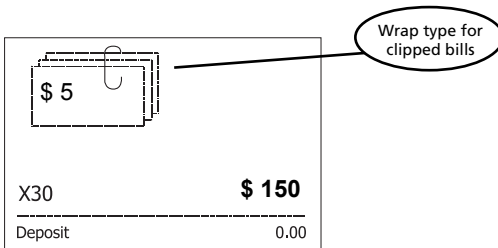
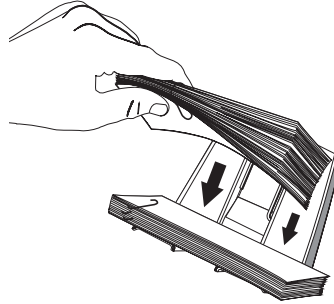

Counting coupons

After **BILLS**, coupons and vouchers can be counted when this function is activated.

- Press the **bills** key to select the coupon.
- Coupons and vouchers can be counted by stacking on the hod or keying in their value using the keypad.
- Stack the coupons in the same way as you would for loose bills.
- If the coupons have not been calibrated, please contact your Tellermate dealer.

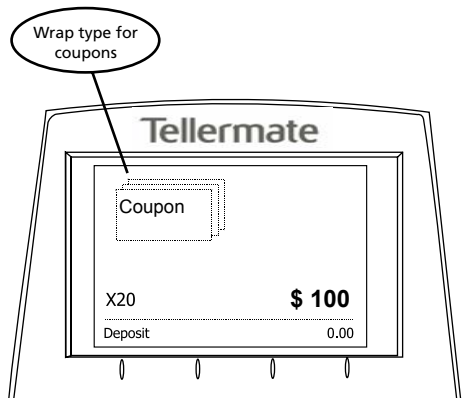

Counting Full Rolls



Your TY is setup to count rolls of money. The next three sections show how to count rolls.

Full Roll allows you to check standard rolls of coin without pre-selecting a denomination.

- Use the COINS key to select Full Roll.
- Put the full roll on the hod. (TY automatically recognizes the denomination)
- The display will say 'ADD ANOTHER'. If you have more full rolls place them on the hod one by one.
- The TY will hold about 7-8 full rolls on the hod.
- If 'SUSPECT ROLL' is displayed, take the roll off the hod and count as a part full roll. - See also page 13.

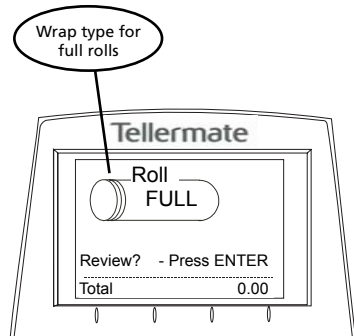
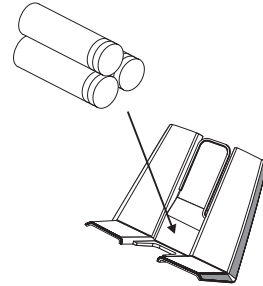
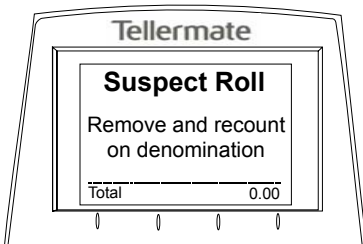

Review table

This mode allows you to manually add your full rolls into the total, without checking them on the TY.

- Use the COINS key to select Full ROLL.
- Press the ENTER key to access the review table.
- Select the denomination by using the BILLS key.
- Enter the quantity of full rolls you have for each denomination by using the MENU key to add a roll and the \$ key to subtract a roll.
- Press END to exit.

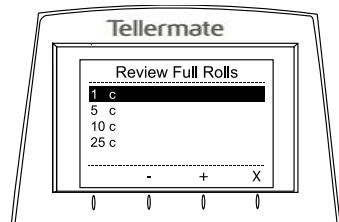

Counting - Coins



Counting Rolls (or part full rolls)

Roll mode allows you to count the contents of a roll (full / part full) of a pre-selected denomination.

- Use the COINS key to select the denomination.
- Press the WRAP key to select Roll mode.
- Put the roll on the hod and the TY will display the value of its contents.

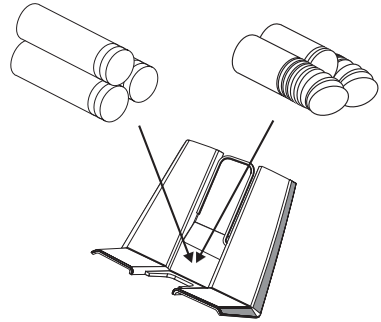

Cups & Scoop

Cup or scoop mode allows you to count loose coins. Each denomination has to be counted separately.

- Use the COINS key to select a denomination.
- Press the WRAP key to select scoop or cup mode.
- Scoop mode: Place the empty scoop on the hod and place the loose coins into the scoop.
Or: Place the coin filled scoop directly on to the hod.
- Cup Mode: Place the coin filled cups on the hod.

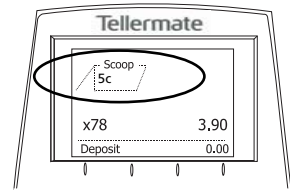

Scoop mode

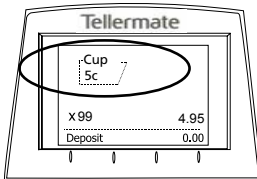
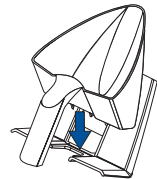

Cup mode

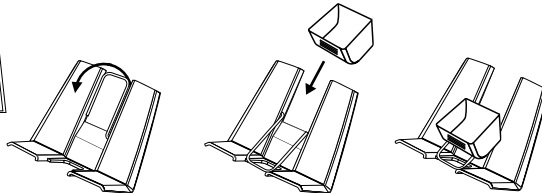

Note: Please lower metal coin tray for cup counting.



To make up full rolls of coin, place the empty scoop on the hod and add coins until the required value is displayed.

When "AutoScroll" is activated the TY will scroll automatically to the next denomination, in sequence from the lowest to the highest value.



Coin denominations must always be separated before counting.

Do not count rolls of coin in the scoop or cups; count rolls directly on the TY hod.



Please note: The US government issued pennies made from 2 different alloys, and therefore it is possible when counting pennies to be a few pennies off. This issue only affects pennies and no other denomination.

A number of features in the TY can be configured to suit your counting needs and preferences ranging from sound control, printer set up and enabling the Bank function.

The menu can be activated by pressing the MENU button on your TY when in the "Select Task" menu or when in counting mode.

AutoAdd

This function automatically adds the value that has been placed on the hod into a running total. When you have placed your money on the hod the TY beeps. When you remove the money the TY will beep again and display +++ADDED+++. This confirms that the money has been added into the running total displayed at the bottom of the screen.

To change either of these functions, press the MENU key, scroll up and down using the BILLS key to highlight the required option, then press the MENU button to turn the function ON (✓) or OFF (✕).

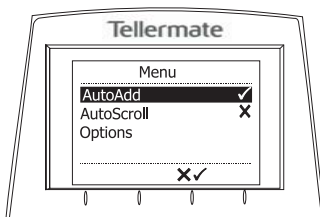

AutoScroll

This function allows the TY to automatically move onto the next denomination. When you have placed your money on the hod the TY beeps. When you remove the money the TY will beep again and then move onto the next denomination.

To change either of these functions, press the MENU key, scroll up and down using the BILLS key to highlight the required option, then press the MENU button to turn the function ON (✓) or OFF (✕).

Options

To change any of these options when you are in a count mode, press the MENU key, scroll up and down using the BILLS key to highlight Options, then press the ENTER key. You are now in the options menu. Scroll up and down using the bills key to select the option you wish to change and press ENTER.

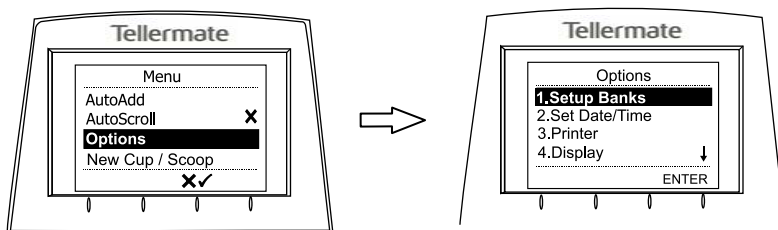

Press "MENU" button > Options >

Setup Bank values (Retail models only)

Bank values can be changed using the ON.OFF (-) or \$ (+) key and enabled or disabled using the MENU key. The Banks can be changed as well by using the BILLS key to scroll up and down. When starting the Tellermate, the BANK key is pushed to activate the Bank.

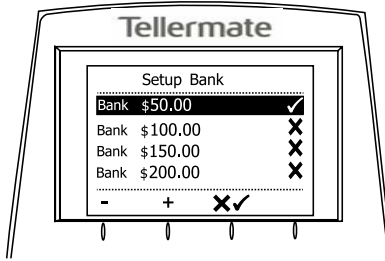

Set Date/Time (for print outs)

You can set the time by selecting the \$ (-) key, the MENU key (+) and the ENTER (next) button. You can set the time as well by using the keypad. Press the PLUS (+) key to accept the information and move on. Once you have completed entering the time and date, press END repeatedly to exit.

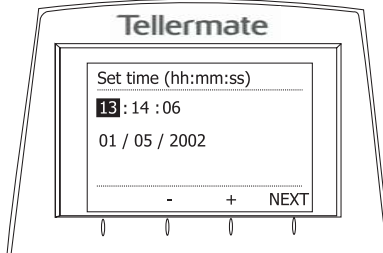

Printer

This function allows the printer to be enabled or disabled by pressing the MENU key. Line by line printing can also be enabled to print each transaction as it happens, rather than everything at the end of the count. Press END to exit.

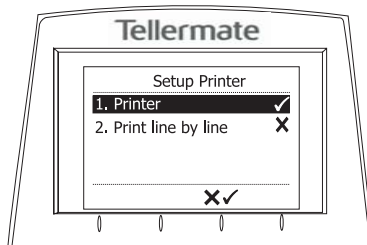

Please see page 6 how to connect the printer

Display

This allows you to adjust the screen contrast. Pressing down on the BILLS key will darken the display and pressing the top of the BILLS key will brighten the display.

The software version of your TY is also displayed in this option. Press END to exit.

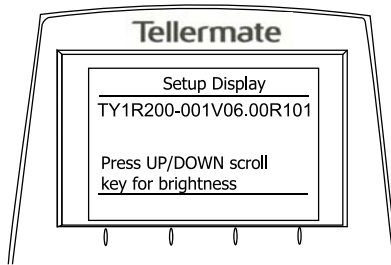

Sound

This option allows adjustment of the following features using the MENU key.

1. Volume
2. Key Click - the sound made when a key is pressed
3. Cash Stack Beep - occurs each time money is placed on the hod
4. Beep 100 Notes - occurs when you reach the bundle quantity for the denomination (to assist in bundle preparation)

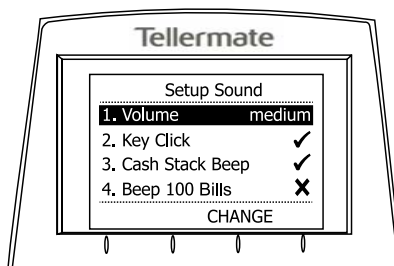

It may become necessary to re-calibrate the weight of a wrap that is stored in the machine, for example when using a different scoop or coin container.

Calibrating cups and scoops

- Start the counting mode
- Press the WRAP key to select Cup mode or Scoop mode.
- Press the MENU key, and scroll down to Calibrate New Cup or Scoop, and press ENTER.
- Follow on-screen instructions: Please put empty scoop or cup on the hod as indicated.
- Once you have calibrated your wrap, press the END key.
- Start counting as normal.

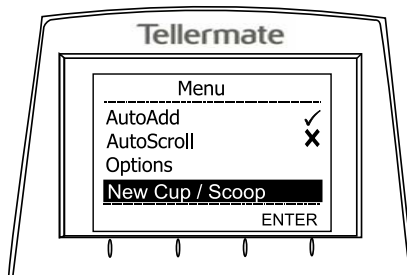

Important

- Don't use different cups or scoops at the same time!
- For calibration of
 - money denominations (bills / coins)
 - other wrap types (bundles, clips, etc.),
 - other currencies (Mexican Peso, Canadian Dollar, etc.)please contact your service Helpline.

Using the keypad



The optional keypad allows you to enter reference numbers and non-cash items such as checks and credit card values. It can also be used to directly enter the amount of any denomination, rather than counting on the TY system, and as a calculator.

Keying in non-cash items

- When in count mode press the NON-CASH key on the keypad.
- If you have more than one non-cash item enabled, press the NON-CASH key to scroll through the items.
- Key in the amount of the non-cash value by pressing the appropriate keys on the keypad, and press the PLUS (+) key to accept the amount.
- If you make a mistake while entering non-cash items select the line you want to delete with the MINUS (-) key on the key pad and then press the CE key (the one on the panel, NOT the one on the key pad!) to clear this entry and start again.
- To exit from non-cash mode, press either the BILLS or the COINS key.



Keying in a denomination

- When in count mode select the denomination using the PLUS (+) and MINUS (-) keys on the keypad.
- Key in the amount of the denomination by pressing the appropriate keys on the keypad. Press the PLUS (+) key to accept the amount.
- If you make a mistake while entering a denomination, select the denomination and press the CE key to clear the entry and start again.

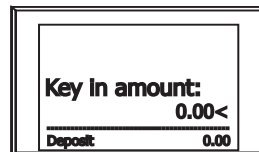

Calculator

- Press CALC on the keypad.
- Use the keypad as a normal desktop Calculator.
- If a printer is connected, you can also choose to print out your calculations.
- To exit out of Calculator mode, press the CALC key.

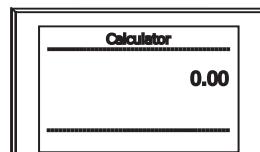

Why is my TY displaying values when there is no money present?

1. The TY is in a draft. Move the system.
2. There is something resting on the TY. Ensure that the TY is kept clear.

During a count, why won't the TY keep a running total?

The AutoAdd function is turned off. To turn the AutoAdd function on, press the MENU button and highlight AutoAdd. Press the MENU button so AutoAdd has a ✓ next to it instead of an X. Press the END button to exit this screen and return to your count.

Why won't the TY automatically advance to the next denomination?

The AutoScroll function is turned off. To turn the AutoScroll function on, press the MENU button and highlight AutoScroll. Press the MENU button so AutoScroll has a ✓ next to it instead of an X. Press the END button to exit and return to your count.

What is the WRAP key?

Press the WRAP key to adjust your TY to different wrap types: Cup, scoop or roll for coins, loose/strap or clip for bills.

Why is my TY miscounting coins?

Please check first that you are using the correct WRAP type. Then check that the cup or scoop has not been left on the TY since the last time that it was used. Have a look on page 18: calibration of different wrap types. If the TellerMate is still miscounting please contact the Helpline for recalibration of the coins.

Please note: The US government issued pennies made from 2 different alloys, and therefore it is possible when counting pennies to be a few pennies off. This issue only affects pennies and no other denomination.

Why is my TY not powering up?

Ensure that the power supply is plugged in and that the power supply light on the right hand side of the TY unit comes on green or red.

Why doesn't my TY count the start bank?

Ensure that you press the "Bank" button before starting to count.

Technical Specification



Load capability:

- | | | | |
|----|-----------------------|---|---------------------|
| TY | - maximum load | ● | 3lbs 5oz (1.5kg) |
| | - counting resolution | ● | 1 banknote / 1 coin |

Dimensions:

- | | | | | |
|----|---|--------|-------|---------------------|
| TY | ● | Depth | 11.1" | (282mm) |
| | ● | Width | 6.0" | (152mm) |
| | ● | Height | 6.0" | (150mm) (incl. hod) |

- | | | | | |
|--------|---|--------|------|---------|
| Keypad | ● | Depth | 5.0" | (126mm) |
| | ● | Width | 3.5" | (90mm) |
| | ● | Height | 1.0" | (24mm) |

Weight:

- | | | |
|--------------|---|-------------------|
| TY | ● | 2lbs 14oz (1.3kg) |
| Keypad & hod | ● | 4.6oz (0.13kg) |
| Battery | ● | 7.0oz (0.20kg) |

Power supply:

- | | | |
|--------------------------------------|---|---|
| Power adapter to TY | ● | Input to suit country of use |
| | ● | Output 13.5v AC 350mA |
| Power connection | ● | 2.5mm reverse jack on the rear panel of the TY |
| Power indication | ● | A bi-color LED on the lower front face illuminates GREEN when the unit is on and the battery, if fitted, is charged; RED when the battery is charging |
| Removable, rechargeable NiMH Battery | ● | Duration of battery: In excess of 8 hours of constant use. |
| | ● | Charging time 14 hours |

Technical Specification



External interfaces:

- Keypad ● Two keypad connectors, one on the back of unit and one on the underside
- Port 1 ● FCC68 8-way connector to printer or PC. RS232 interface baud rates up to 38,400
- Port 2 ● FCC68 8-way connector to printer
- Port 3 ● Ethernet Adaptor FCC68 cat 5 8-way connector to network
or
● USB (1.1)-B connector to PC

User interface:

- Display ● Full graphic LCD 60mm x 42mm (2.4" x 1.7"), 128 x 64 pixel resolution with user adjustable contrast
- Front panel ● 9 soft touch buttons

Environmental conditions:

- Storage temperature range ● - 20°C to + 60°C (-4°F to +140°F)
- Operating temperature range ● +5°C to +40°C (+40°F to +104°F)
- Humidity range ● 0% to 95% RH non-condensing

EC Declaration of Conformity

This is to certify that:

The Tellermate money counter models **TY-B100, TY-B180, TY-R100, TY-R150, TY-R200, TY-R300, TY-R330, TY-R350** manufactured by Tellermate plc, Leeway, Newport, UK, conform to the Low Voltage Directive 73/23/EEC, and the Electromagnetic Compatibility Directive 89/336/EEC as modified by 92/31/EEC by application of the following standards:

- | | | |
|----------------|------|--|
| BS EN 60950-1: | 2002 | Low voltage standard |
| EN5022: | 1998 | Generic emission standard part 1:
Residential, commercial and light industrial. |
| EN55024: | 1998 | Generic immunity standard part 1:
Residential, commercial and light industrial. |

Signed for Tellermate Plc

Approvals



N. Burroughs Development Director