

# SRS Crisafulli, Inc.

Product Catalogue - Section Six  
Portable Power Units



Copyright © 2008 SRS Crisafulli, Inc. All rights reserved.

| Table of Contents |  | Page         |
|-------------------|--|--------------|
| <b>Section 6</b>  | <b>Portable Power Units - 60 models</b>                    | <b>6 - 1</b> |
|                   | Diesel-Hydraulic Power Unit - Trailer mounted - 7 models   | 6 - 2        |
|                   | Diesel-Hydraulic Power Unit - Skid mounted - 7 models      | 6 - 3        |
|                   | Diesel-PTO Power Unit - Trailer mounted - 7 models         | 6 - 4        |
|                   | Diesel-PTO Power Unit - Skid mounted - 7 models            | 6 - 5        |
|                   | Electric-Hydraulic Power Unit - Trailer mounted - 8 models | 6 - 6        |
|                   | Electric-Hydraulic Power Unit - Skid mounted - 8 models    | 6 - 7        |
|                   | Electric-PTO Power Unit - Trailer mounted - 8 models       | 6 - 8        |
|                   | Electric-PTO Power Unit - Skid mounted - 8 models          | 6 - 9        |



Diesel-Hydraulic Power Units - Trailer or Skid mounted - 14 models  
- Horsepower 25 - 250 - Hydraulic output 15 - 150 GPM

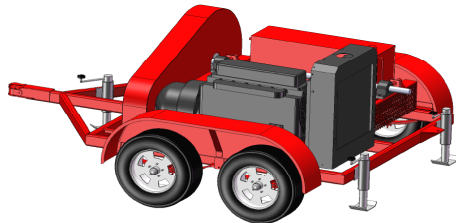
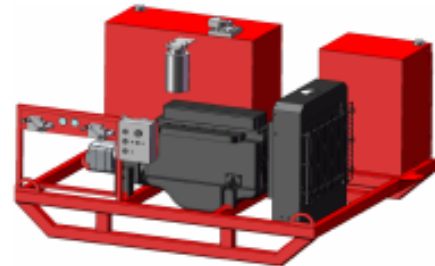

Diesel-PTO Power Units - Trailer or Skid mounted - 14 models  
- Horsepower 25 - 250 - RPM 540 or 1000

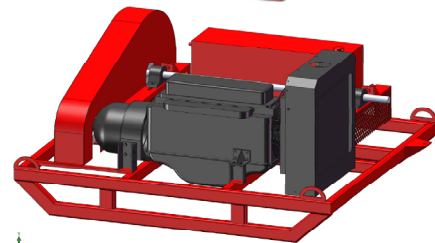

Electric-Hydraulic Power Units - Trailer or Skid mounted - 16 models  
- Horsepower 25 - 250 - Hydraulic output 15 - 150 GPM

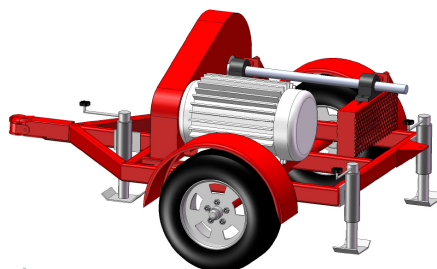
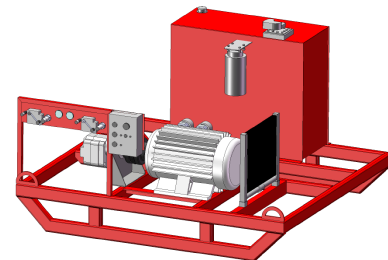

Electric-PTO Power Units - Trailer or Skid mounted - 16 models - Horsepower 25 - 250 - RPM 540 or 1000

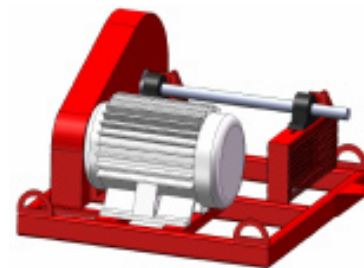

**Pumps - Dredges - Power Units - Custom or Standard**  
**Manufacturers of reliable Crisafulli products supported by superior service worldwide**

SRS Crisafulli, Inc. - 1610 Crisafulli Drive - P.O. Box 1051 - Glendive, MT 59330 - USA

Phone: 406-365-3393 - Toll free: 800-442-7867 - Fax: 406-365-8088

E-mail: srsc@crisafulli.com - www.crisafulli.com www.dredge.net

SRS Crisafulli, Inc. - Product Catalogue

# SRS Crisafulli, Inc.

Product Catalogue - Section Six  
Portable Power Units



Copyright © 2008 SRS Crisafulli, Inc. All rights reserved.

## DIESEL-HYDRAULIC POWER UNITS - Trailer Mounted

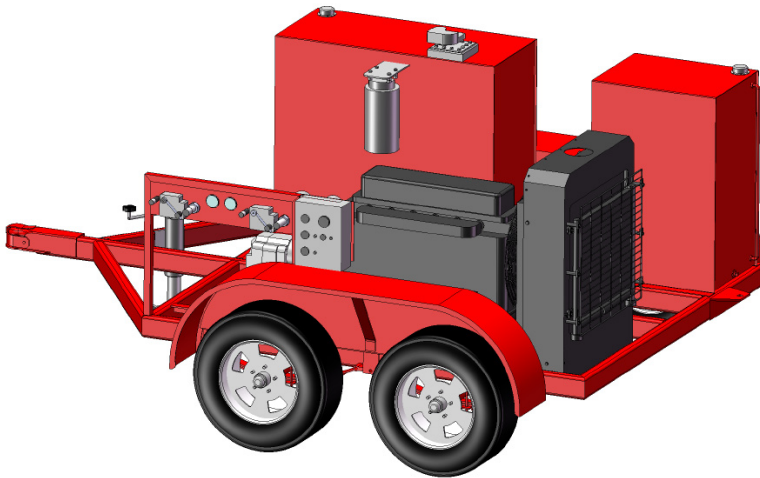

**Description.** SRS Crisafulli diesel - hydraulic power units have an industrial duty diesel engine with extended exhaust stack & raincap mounted on an industrial duty trailer, hitch jack, a heavy-duty hydraulic pump, suction screen, fluid reservoir, fluid level gauge, fluid temperature gauge, breather/fill cap, ten micron return-line filter, optional flow control, system pressure gauge, fluid cooler, and all necessary hydraulic fittings. Battery, emergency safety engine shutdown system and fuel tank for 10 hours of continuous operation are included.  
**Performance Range; hydraulic output of 15 - 150 GPM. NOTE: The diesel PTO power unit trailers are not DOT approved for travel on public roads.**

|                                    |                             |
|------------------------------------|-----------------------------|
| * Industrial Duty Diesel Engine    | * Safety Shutdown System    |
| * Extended Exhaust w/Rain Cap      | * 10 Hour Fuel Reservoir    |
| * Heavy Duty Hydraulic Pump        | * Heavy Duty Trailer        |
| * Baffled Fluid Reservoir          | * Return Circuit Filtration |
| * Adjustable Pressure Relief Valve |                             |

| Model/<br>Part<br>Number | Horsepower<br>(HP) | Hydraulic<br>Output<br>(GPM) | Maximum<br>Hydraulic<br>Pressure (PSI) | Weight<br>Estimated<br>- Lbs |
|--------------------------|--------------------|------------------------------|--|------------------------------|
| PUDH25T                  | 25                 | 15                           | 2,000                                  | 2,400                        |
| PUDH50T                  | 50                 | 30                           | 2,000                                  | 2,600                        |
| PUDH75T                  | 75                 | 45                           | 2,000                                  | 3,200                        |
| PUDH110T                 | 110                | 75                           | 2,000                                  | 3,600                        |
| PUDH150T                 | 150                | 90                           | 2,000                                  | 4,500                        |
| PUDH200T                 | 200                | 120                          | 2,000                                  | 6,000                        |
| PUDH250T                 | 250                | 150                          | 2,000                                  | 6,500                        |

(Larger hydraulic flow rates & pressures are available; consult Factory for details.)

### Standard Options & Accessories

|                                    |  |
|------------------------------------|--|
| On/Off & Reversing Control Valve   | Multiple Circuits w/ Flow Control          |
| DOT Light Package                  | 8 GPM Auxiliary Hydraulic Circuit          |
| Electric Brakes (per axle)         | Hydraulic Hose & Quick Coupler Fittings    |
| Picker crane with Electric Winch   | High Pressure High Efficiency Piston Pumps |
| Pump Basket                        | Optional Hitch Configurations              |
| Roll Over Protection System (ROPS) | Sound Attenuated or Weather Enclosures     |
| Hose Rack or Reel                  |  |

\*Power Unit will meet or exceed stated HP for continuous operation at rated RPM.

### Pumps - Dredges - Power Units - Custom or Standard

**Manufacturers of reliable Crisafulli products supported by superior service worldwide**

SRS Crisafulli, Inc. - 1610 Crisafulli Drive - P.O. Box 1051 - Glendive, MT 59330 - USA

Phone: 406-365-3393 - Toll free: 800-442-7867 - Fax: 406-365-8088

E-mail: srsc@crisafulli.com - www.crisafulli.com www.dredge.net

# SRS Crisafulli, Inc.

Product Catalogue - Section Six  
Portable Power Units



Copyright © 2008 SRS Crisafulli, Inc. All rights reserved.

## DIESEL-HYDRAULIC POWER UNITS - Skid Mounted

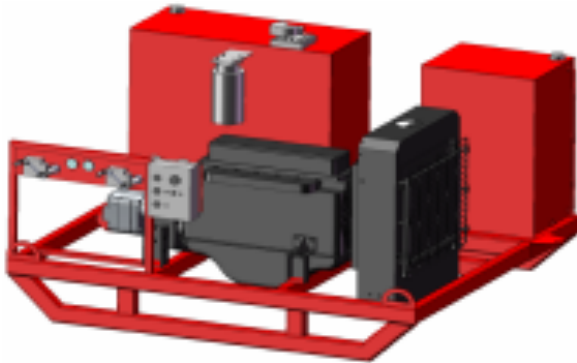

**Description.** SRS Crisafulli diesel - hydraulic power units have an industrial duty diesel engine with extended exhaust stack & raincap mounted on an industrial duty skid, a heavy-duty hydraulic pump, suction screen, fluid reservoir, fluid level gauge, fluid temperature gauge, breather/fill cap, ten micron return-line filter, optional flow control, system pressure gauge, fluid cooler, and all necessary hydraulic fittings. Battery, emergency safety engine shutdown system and fuel tank for 10 hours of continuous operation are included. **Performance Range; hydraulic output of 15 - 150 GPM.**

|   |   |
|---|---|
| * <b>Industrial Duty Diesel Engine</b>    | * <b>Safety Shutdown System</b>         |
| * <b>Extended Exhaust w/Rain Cap</b>      | * <b>10 Hour Fuel Reservoir</b>         |
| * <b>Heavy Duty Hydraulic Pump</b>        | * <b>Heavy Duty Skid w/Lifting Eyes</b> |
| * <b>Baffled Fluid Reservoir</b>          | * <b>Return Circuit Filtration</b>      |
| * <b>Adjustable Pressure Relief Valve</b> |   |

| Model/<br>Part<br>Number | Horsepower<br>(HP) | Hydraulic<br>Output<br>(GPM) | Maximum<br>Hydraulic<br>Pressure (PSI) | Weight<br>Estimated<br>(Lbs) |
|--------------------------|--------------------|------------------------------|--|------------------------------|
| PUDH25                   | 25                 | 15                           | 2,000                                  | 2,600                        |
| PUDH50S                  | 50                 | 30                           | 2,000                                  | 2,800                        |
| PUDH75S                  | 75                 | 45                           | 2,000                                  | 3,400                        |
| PUDH110S                 | 110                | 75                           | 2,000                                  | 3,800                        |
| PUDH150S                 | 150                | 90                           | 2,000                                  | 4,700                        |
| PUDH200S                 | 200                | 120                          | 2,000                                  | 6,200                        |
| PUDH250S                 | 250                | 150                          | 2,000                                  | 6,700                        |

(Larger hydraulic flow rates & pressures are available; consult Factory for details.)

### Standard Options & Accessories

|  |   |
|--|---|
| On/Off & Reversing Control Valve   | Multiple Circuits w/ Flow Control       |
| Sound Attenuated or Weather Enclosures   | 8 GPM Auxiliary Hydraulic Circuit       |
| Hose Rack or Reel  | Hydraulic Hose & Quick Coupler Fittings |
| Picker crane with Electric Winch   | Pump Basket                             |
| High Pressure High Efficiency Piston Pumps                                       |   |
| *Power Unit will meet or exceed stated HP for continuous operation at rated RPM. |   |

**Pumps - Dredges - Power Units - Custom or Standard**  
**Manufacturers of reliable Crisafulli products supported by superior service worldwide**

SRS Crisafulli, Inc. - 1610 Crisafulli Drive - P.O. Box 1051 - Glendive, MT 59330 - USA

Phone: 406-365-3393 - Toll free: 800-442-7867 - Fax: 406-365-8088

E-mail: srsc@crisafulli.com - www.crisafulli.com www.dredge.net

6-3 - SRS Crisafulli, Inc. - Product Catalogue

# SRS Crisafulli, Inc.

Product Catalogue - Section Six  
Portable Power Units



Copyright © 2008 SRS Crisafulli, Inc. All rights reserved.

## DIESEL- PTO POWER UNITS - Trailer Mounted

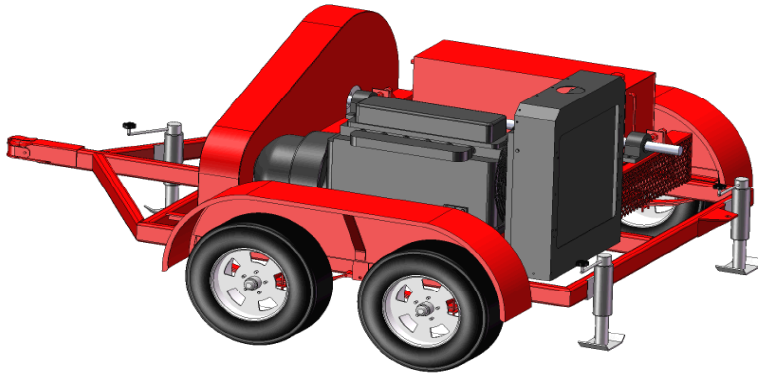

**Description.** SRS Crisafulli Diesel PTO Power Units have industrial duty diesel engines with extended exhaust stacks & raincaps mounted on industrial duty skids or trailers, speed reduction, (540 RPM resultant speed if not specified otherwise), safety guards, ball hitch, hitch jack, power shaft and auxiliary pump hitch plate. Battery, emergency safety engine shutdown system and fuel tank for 10 hours of continuous operation are included. The diesel PTO power units are designed for use with any standard Crisafulli™ PTO powered trailer pump.  
**Performance Range; Horsepower of 25 - 250 HP. NOTE: The diesel PTO power unit trailers are not DOT approved for travel on public roads.**

|                                 |                                  |
|---------------------------------|----------------------------------|
| * Industrial Duty Diesel Engine | * Heavy Duty Trailer             |
| * Extended Exhaust w/Rain Cap   | * Speed Reduction w/Safety Guard |
| * Safety Shutdown System        | * PTO Output                     |
| * 10 Hour Fuel Reservoir        | * Stabilizer Jacks Included      |

| Model/<br>Part<br>Number | Horsepower<br>(HP) | PTO<br>SPEED<br>(RPM) | Weight<br>Estimated<br>(Lbs) |
|--------------------------|--------------------|-----------------------|------------------------------|
| PUDP25T                  | 25                 | 540/1000              | 1,400                        |
| PUDP50T                  | 50                 | 540/1000              | 1,600                        |
| PUDP75T                  | 75                 | 540/1000              | 2,000                        |
| PUDP110T                 | 110                | 540/1000              | 2,500                        |
| PUDP150T                 | 150                | 540/1000              | 3,400                        |
| PUDP200T                 | 200                | 540/1000              | 5,000                        |
| PUDP250T                 | 250                | 540/1000              | 5,200                        |

| Standard Options & Accessories   |  |
|--|--|
| Electric Brakes (per axle)   | Sound Attenuated or Weather Enclosures |
| Optional Hitch Configurations  | DOT Light Package                      |
| 8 GPM Auxiliary Hydraulic Circuit  | Roll-over Protection System (ROPS)     |
| *Power Unit will meet or exceed stated HP for continuous operation at rated RPM. |  |

**Pumps - Dredges - Power Units - Custom or Standard**  
**Manufacturers of reliable Crisafulli products supported by superior service worldwide**

SRS Crisafulli, Inc. - 1610 Crisafulli Drive - P.O. Box 1051 - Glendive, MT 59330 - USA

Phone: 406-365-3393 - Toll free: 800-442-7867 - Fax: 406-365-8088

E-mail: srsc@crisafulli.com - www.crisafulli.com www.dredge.net

6-4 - SRS Crisafulli, Inc. - Product Catalogue

# SRS Crisafulli, Inc.

Product Catalogue - Section Six  
Portable Power Units



Copyright © 2008 SRS Crisafulli, Inc. All rights reserved.

## DIESEL- PTO POWER UNITS - Skid Mounted

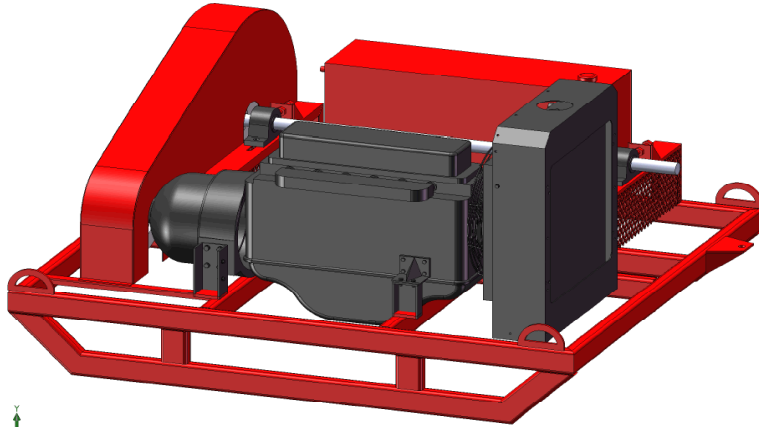

**Description.** SRS Crisafulli Diesel PTO Power Units have industrial duty diesel engines with extended exhaust stacks & raincaps mounted on industrial duty skids, speed reduction, (540 RPM resultant speed if not specified otherwise), safety guards, power shaft and auxiliary pump hitch plate. Battery, emergency safety engine shutdown system and fuel tank for 10 hours of continuous operation are included. The diesel PTO power units are designed for use with any standard Crisafulli™ PTO powered trailer pump. **Performance Range; Horsepower of 25 - 250 HP.**

|                                 |                                   |
|---------------------------------|-----------------------------------|
| * Industrial Duty Diesel Engine | * Heavy Duty Skid w/ Lifting Eyes |
| * Extended Exhaust w/Rain Cap   | * Speed Reduction w/Safety Guard  |
| * Safety Shutdown System        | * PTO Output                      |
| * 10 Hour Fuel Reservoir        |                                   |

| Model/<br>Part<br>Number | Horsepower<br>(HP) | PTO<br>SPEED<br>(RPM) | Weight<br>Estimated<br>(Lbs) |
|--------------------------|--------------------|-----------------------|------------------------------|
| PUDP25S                  | 25                 | 540/1000              | 1,600                        |
| PUDP50S                  | 50                 | 540/1000              | 1,800                        |
| PUDP75S                  | 75                 | 540/1000              | 2,200                        |
| PUDP110S                 | 110                | 540/1000              | 2,700                        |
| PUDP150S                 | 150                | 540/1000              | 3,600                        |
| PUDP200S                 | 200                | 540/1000              | 5,200                        |
| PUDP250S                 | 250                | 540/1000              | 5,400                        |

| Standard Options & Accessories   |  |
|--|--|
| 8 GPM Auxiliary Hydraulic Circuit  | Sound Attenuated or Weather Enclosures |
| *Power Unit will meet or exceed stated HP for continuous operation at rated RPM. |  |

**Pumps - Dredges - Power Units - Custom or Standard**  
**Manufacturers of reliable Crisafulli products supported by superior service worldwide**

SRS Crisafulli, Inc. - 1610 Crisafulli Drive - P.O. Box 1051 - Glendive, MT 59330 - USA

Phone: 406-365-3393 - Toll free: 800-442-7867 - Fax: 406-365-8088

E-mail: srsc@crisafulli.com - www.crisafulli.com www.dredge.net

6-5 - SRS Crisafulli, Inc. - Product Catalogue

# SRS Crisafulli, Inc.

Product Catalogue - Section Six  
Portable Power Units



Copyright © 2008 SRS Crisafulli, Inc. All rights reserved.

## ELECTRIC-HYDRAULIC POWER UNITS - Trailer Mounted

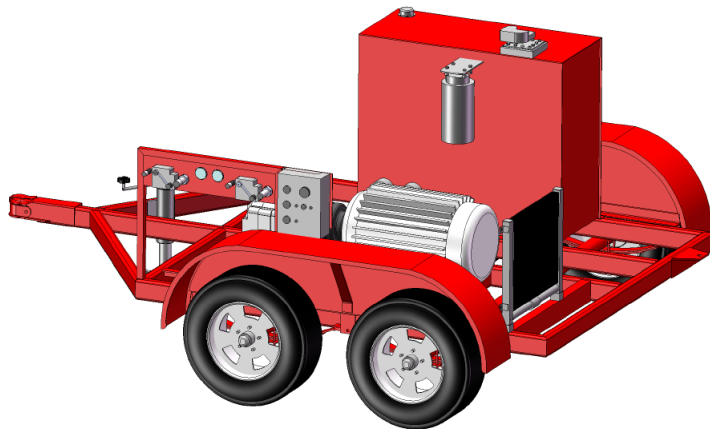

**Description.** SRS Crisafulli electric - hydraulic power units have totally enclosed, fan cooled electric motor mounted on industrial duty trailers, with a heavy-duty hydraulic pump, hitch jack, suction screen, fluid reservoir, fluid level gauge, fluid system pressure gauge, temperature gauge, breather/fill cap, ten micron return line filter, flow control valve, pressure relief valve (set at 2000 PSI), fluid cooler, cooling fans.

**Performance Range: hydraulic output 15 - 150 GPM. NOTE: The Electric- Hydraulic power units are not DOT approved for travel on public roads.**

|  |                             |
|--|-----------------------------|
| * Totally Enclosed Electric Motor (TEFC) | * Return Circuit Filtration |
| * Heavy Duty Hydraulic Pump              | * Baffled Fluid Reservoir   |
| * Adjustable Pressure Relief Valve       | * Heavy Duty Trailer        |

| Model/<br>Part<br>Number | Horsepower<br>(HP) | Maximim<br>Hydraulic<br>Output<br>(GPM) | Maximim<br>Hydraulic<br>Pressure<br>(PSI) | Weight - Lbs<br>Estimated |
|--------------------------|--------------------|---|---|---------------------------|
| PUEH25T                  | 25                 | 15                                      | 2000                                      | 1,700                     |
| PUEH50T                  | 50                 | 30                                      | 2000                                      | 2,100                     |
| PUEH75T                  | 75                 | 45                                      | 2000                                      | 2,700                     |
| PUEH100T                 | 100                | 60                                      | 2000                                      | 3,300                     |
| PUEH125T                 | 125                | 75                                      | 2000                                      | 4,000                     |
| PUEH150T                 | 150                | 90                                      | 2000                                      | 5,000                     |
| PUEH200T                 | 200                | 120                                     | 2000                                      | 6,000                     |
| PUEH250T                 | 250                | 150                                     | 2000                                      | 6,400                     |

(Larger hydraulic flow rates & pressures are available; consult Factory for details.)

### Standard Options & Accessories

|   |  |
|---|--|
| ON/Off Reversing Control Valve          | Multiple Circuits w/ Flow Control          |
| Electric Brakes (per axle)              | Full Enclosures                            |
| Picker Crane with Electric Winch        | DOT Light Package                          |
| Explosion-proof Motor                   | Optional Hitch Configurations              |
| Hydraulic Hose & Quick Coupler Fittings | Starter Panel                              |
| Roll Over Protection System (ROPS)      | High Pressure High Efficiency Piston Pumps |
| Pump Basket                             | Hose Rack or Reel                          |

### Pumps - Dredges - Power Units - Custom or Standard

**Manufacturers of reliable Crisafulli products supported by superior service worldwide**

SRS Crisafulli, Inc. - 1610 Crisafulli Drive - P.O. Box 1051 - Glendive, MT 59330 - USA

Phone: 406-365-3393 - Toll free: 800-442-7867 - Fax: 406-365-8088

E-mail: srsc@crisafulli.com - www.crisafulli.com www.dredge.net

6-6 - SRS Crisafulli, Inc. - Product Catalogue

# SRS Crisafulli, Inc.

Product Catalogue - Section Six  
Portable Power Units



Copyright © 2008 SRS Crisafulli, Inc. All rights reserved.

## ELECTRIC-HYDRAULIC POWER UNITS - Skid Mounted

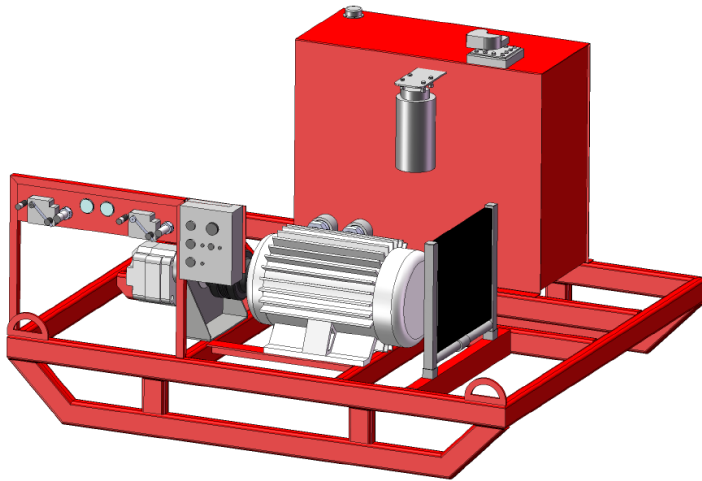

**Description.** SRS Crisafulli electric - hydraulic power units have totally enclosed, fan cooled electric motor mounted on industrial duty skids, with a heavy-duty hydraulic pump, suction screen, fluid reservoir, fluid level gauge, fluid system pressure gauge, temperature gauge, breather/ fill cap, ten micron return line filter, flow control valve, pressure relief valve (set at 2000 PSI), fluid cooler, cooling fans. **Performance Range: hydraulic output 15 - 150 GPM.**

|  |                             |
|--|-----------------------------|
| * Totally Enclosed Electric Motor (TEFC) | * Return Circuit Filtration |
| * Adjustable Pressure Relief Valve       | * Heavy Duty Hydraulic Pump |
| * Heavy Duty Skid w/Lifting Eyes         | * Baffled Fluid Reservoir   |

| Model/<br>Part<br>Number | Horsepower<br>(HP) | Maximim<br>Hydraulic<br>Output<br>(GPM) | Maximim<br>Hydraulic<br>Pressure<br>(PSI) | Weight - Lbs<br>Estimated |
|--------------------------|--------------------|---|---|---------------------------|
| PUEH25S                  | 25                 | 15                                      | 2000                                      | 1,800                     |
| PUEH50S                  | 50                 | 30                                      | 2000                                      | 2,200                     |
| PUEH75S                  | 75                 | 45                                      | 2000                                      | 2,900                     |
| PUEH100S                 | 100                | 60                                      | 2000                                      | 3,500                     |
| PUEH125S                 | 125                | 75                                      | 2000                                      | 4,200                     |
| PUEH150S                 | 150                | 90                                      | 2000                                      | 5,200                     |
| PUEH200S                 | 200                | 120                                     | 2000                                      | 6,200                     |
| PUEH250S                 | 250                | 150                                     | 2000                                      | 6,600                     |

(Larger hydraulic flow rates & pressures are available; consult Factory for details.)

### Standard Options & Accessories

|   |  |
|---|--|
| ON/Off Reversing Control Valve          | Multiple Circuits w/ Flow Control          |
| Picker Crane with Electric Winch        | Full Enclosures                            |
| Hydraulic Hose & Quick Coupler Fittings | Starter Panel                              |
| Explosion-proof Motor                   | High Pressure High Efficiency Piston Pumps |
| Pump Basket                             | Hose Rack or Reel                          |

**Pumps - Dredges - Power Units - Custom or Standard**  
**Manufacturers of reliable Crisafulli products supported by superior service worldwide**

SRS Crisafulli, Inc. - 1610 Crisafulli Drive - P.O. Box 1051 - Glendive, MT 59330 - USA

Phone: 406-365-3393 - Toll free: 800-442-7867 - Fax: 406-365-8088

E-mail: srsc@crisafulli.com - www.crisafulli.com www.dredge.net

6-7 - SRS Crisafulli, Inc. - Power Units

# SRS Crisafulli, Inc.

Product Catalogue - Section Six  
Portable Power Units



Copyright © 2008 SRS Crisafulli, Inc. All rights reserved.

## ELECTRIC - PTO POWER UNITS - Trailer Mounted

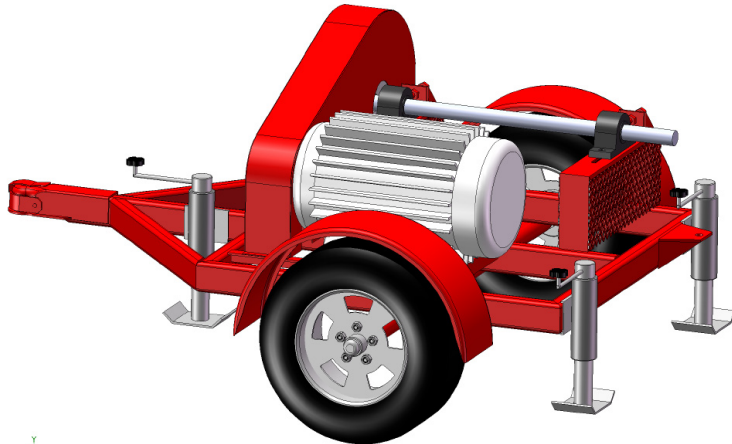

**Description.** SRS Crisafulli Electric-PTO Power units have industrial duty TEFC (totally enclosed, fan cooled) electric motors mounted on heavy duty trailers, equipped with belt and sheave speed reduction (540 RPM resultant speed unless otherwise specified), sheave guard, hitch jack, dual rear stabilizers, ball hitch, intermediate power shaft, and auxiliary pump hitch plate. **Performance Range: Horsepower 25 - 250. NOTE: The Electric- Hydraulic power units are not DOT approved for travel on public roads.**

|  |                             |
|--|-----------------------------|
| * Totally Enclosed Electric Motor (TEFC) | * Heavy Duty Trailer        |
| * Stabilizer                             | * PTO Output                |
| * Speed Reduction w/Safety Guard         | * Stabilizer Jacks Included |

| Model/Part Number | Horsepower (HP) | PTO SPEED (RPM) | Weight - Lbs Estimated |
|-------------------|-----------------|-----------------|------------------------|
| PUEP25T           | 25              | 540/1000        | 1,400                  |
| PUEP50T           | 50              | 540/1000        | 1,600                  |
| PUEP75T           | 75              | 540/1000        | 2,100                  |
| PUEP100T          | 100             | 540/1000        | 2,700                  |
| PUEP125T          | 125             | 540/1000        | 3,300                  |
| PUEP150T          | 150             | 540/1000        | 3,600                  |
| PUEP200T          | 200             | 540/1000        | 4,100                  |
| PUEP250T          | 250             | 540/1000        | 4,600                  |

| Standard Options              |                                    |
|-------------------------------|------------------------------------|
| Electric Brakes (per axle)    | Full Enclosures                    |
| Optional Hitch Configurations | DOT Light Package                  |
| Explosion-proof motors        | Roll-over Protection System (ROPS) |
| Starter Panel                 |                                    |

**Pumps - Dredges - Power Units - Custom or Standard**  
Manufacturers of reliable Crisafulli products supported by superior service worldwide

SRS Crisafulli, Inc. - 1610 Crisafulli Drive - P.O. Box 1051 - Glendive, MT 59330 - USA

Phone: 406-365-3393 - Toll free: 800-442-7867 - Fax: 406-365-8088

E-mail: srsc@crisafulli.com - www.crisafulli.com www.dredge.net

6-8 - SRS Crisafulli, Inc. - Power Units



# SRS Crisafulli, Inc.

Product Catalogue - Section Six  
Portable Power Units



Copyright © 2008 SRS Crisafulli, Inc. All rights reserved.

## ELECTRIC - PTO POWER UNITS - Skid Mounted

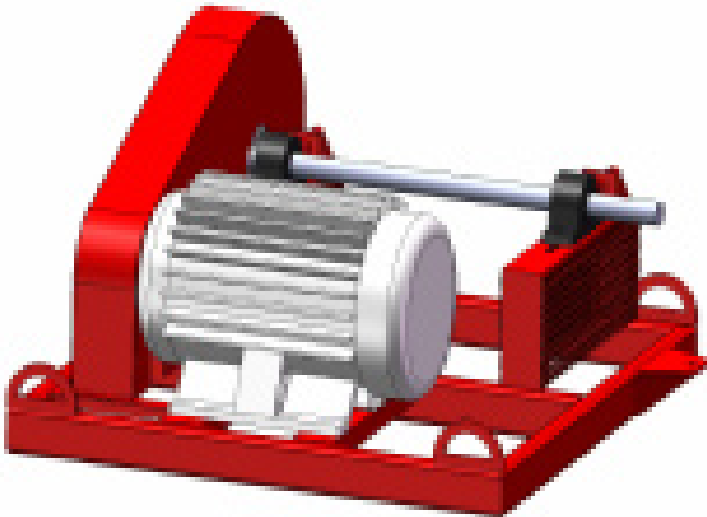

**Description.** SRS Crisafulli Electric-PTO Power units have industrial duty TEFC (totally enclosed, fan cooled) electric motors mounted on heavy duty skids, equipped with belt and sheave speed reduction (540 RPM resultant speed unless otherwise specified), sheave guard, hitch jack, dual rear stabilizers, ball hitch, intermediate power shaft, and auxiliary pump hitch plate. **Performance Range: Horsepower 25 - 250.**

|  |                                   |
|--|-----------------------------------|
| * Totally Enclosed Electric Motor (TEFC) | * Heavy Duty Skid w/ Lifting Eyes |
| * Speed Reduction w/Safety Guard         | * PTO Output                      |

| Model/Part Number | Horsepower (HP) | PTO SPEED (RPM) | Weight Estimated (Lbs) |
|-------------------|-----------------|-----------------|------------------------|
| PUEP25S           | 25              | 540/1000        | 1,500                  |
| PUEP50S           | 50              | 540/1000        | 1,700                  |
| PUEP75S           | 75              | 540/1000        | 2,300                  |
| PUEP100S          | 100             | 540/1000        | 2,900                  |
| PUEP125S          | 125             | 540/1000        | 3,500                  |
| PUEP150S          | 150             | 540/1000        | 3,800                  |
| PUEP200S          | 200             | 540/1000        | 4,300                  |
| PUEP250S          | 250             | 540/1000        | 4,800                  |

| Standard Options       |                 |
|------------------------|-----------------|
| Explosion-proof motors | Full Enclosures |
| Starter Panel          |                 |

**Pumps - Dredges - Power Units - Custom or Standard**  
**Manufacturers of reliable Crisafulli products supported by superior service worldwide**

SRS Crisafulli, Inc. - 1610 Crisafulli Drive - P.O. Box 1051 - Glendive, MT 59330 - USA

Phone: 406-365-3393 - Toll free: 800-442-7867 - Fax: 406-365-8088

E-mail: srsc@crisafulli.com - www.crisafulli.com www.dredge.net

6-9 - SRS Crisafulli, Inc. - Power Units