

cyclonaire[®]

PNEUMATIC CONVEYING SYSTEMS

C&C[®]

Dust Reclaim Systems

**Collect & Convey Dust Back to Silos
During Delivery and Filling Operations**

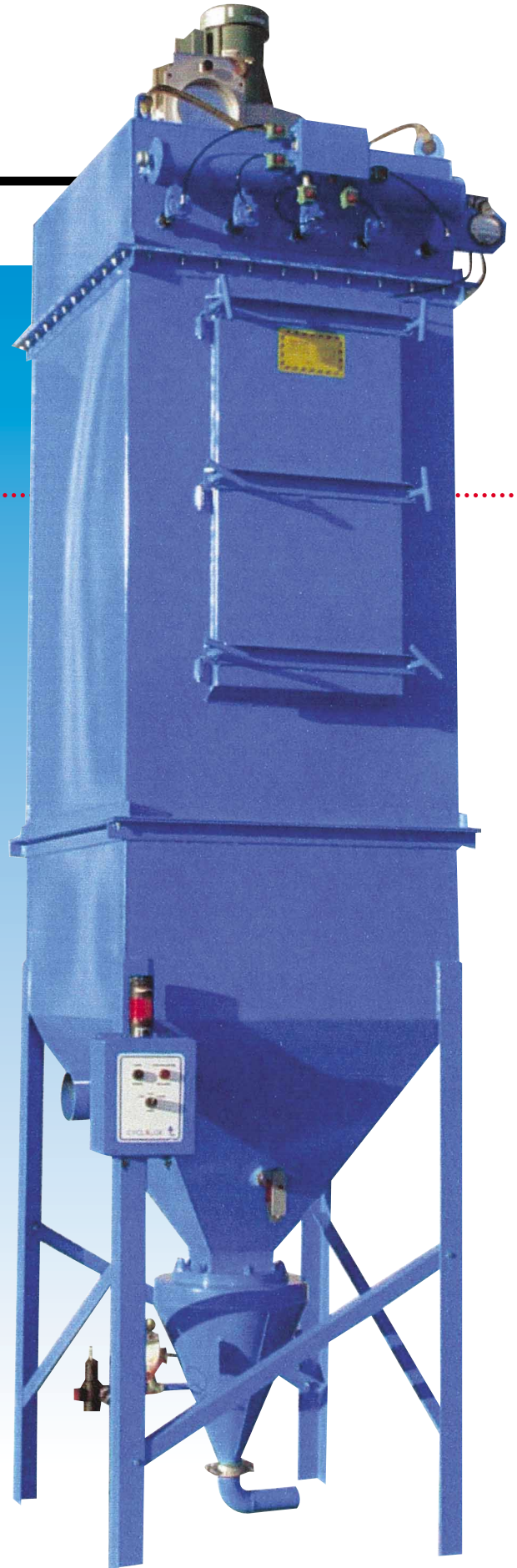

C&C Reclaim System Overview



Get Cleaner Deliveries, More Efficient Storage with C&C Dust Reclaim Systems

Cyclonaire's automated Collect and Convey Reclaim Systems preserve air quality and conserve valuable material by capturing product dust from silo filling operations and automatically returning it directly to source silos. They work in concert with your rail or truck unload system and can be used to recycle dust from all kinds of dry solids – including foodstuffs, corrosive chemicals, and especially highly abrasive materials like cement, slag, and fly ash.

Reclaim Material Economically and Safely

Each C&C Reclaim unit combines an efficient Cyclonaire Pulse Jet Dust Collector with a rugged, gravity-fed CycloLok® Dense Phase Pneumatic Conveyor that operates on plant air and runs only when needed. There's no separate blower, no wasted energy. Automatic onboard controls allow unattended operation and signal when service is needed. For worker safety and convenience, C&C Systems offer servicing from ground-level and easy filter access.

Save Time, Labor, and Product

- Automatic, unsupervised operation
- Convenient servicing from ground-level
- Hinged door for easy filter access
- Prewired integral exhaust fan runs on demand
- Synchronized pulse jet cleaning for peak performance
- Differential pressure gauge indicates need for filter service
- Durable dense phase conveyor has only one moving part
- Controlled, moneysaving as-needed conveying
- Low conveying velocities cut product degradation and component wear

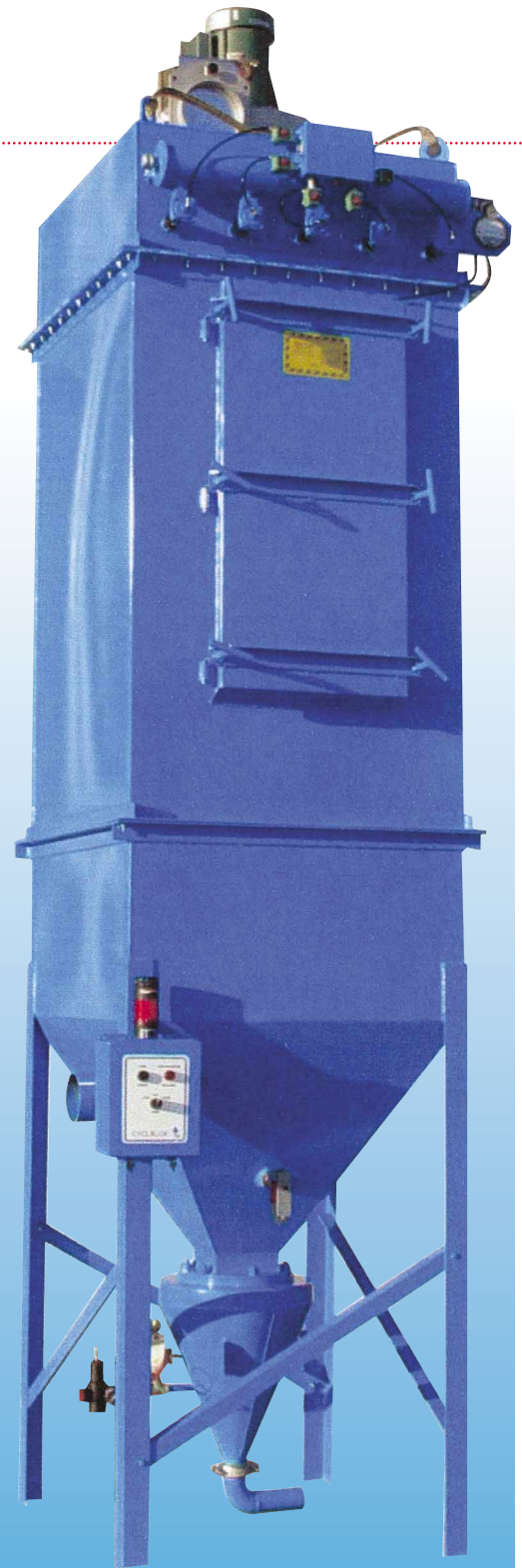

C&C Reclaim Systems efficiently recycle airborne product dust when silos are filled. Units operate automatically from a safe ground-level location – using dense phase conveying to minimize material degradation and component wear as they return product dust to silos.

System Specifications

- Welded and bolted 10-gauge carbon steel construction
- 6-inch diameter tubing inlet stubs for attachment to silo vent tubing
- Pulse jet cleaning mechanism
- Filter area up to 382 sq. ft.
- 16 oz. polyester bags standard
- 12 wire galvanized bag cages
- PLC controls with audio/visual alarms
- NEMA 4 enclosure for timer controls
- Pressure rated to 17" H₂O
- Fan selection to fit system requirements, including flow and static pressure
- Dirty air plenum with 60° material hopper
- High-level sensor in hopper
- Dense phase CycloLok® Conveyor
- Conveying capacity up to 2+ TPH

Options

- Stainless steel material contact construction
- Controls for environments requiring NEMA 7/9 enclosures

System Requirements

- Average 20-30 cu. ft. air usage per convey cycle
- 5-15 scfm clean, dry air for filter cleaning
- 90-100 psig air supply
- 110 vac, 60 Hz for controls
- 230/460 vac, 60 Hz for exhaust fan

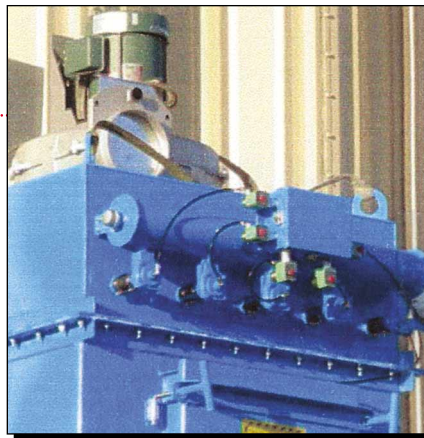

Exhaust Fan draws particle-laden silo air through the dust collector. **Pulse Jet Dust Collector** captures and then automatically cleans product dust from the filter media with reverse air pulses, discharging the collected material into the collection hopper.



CycloLok® Control Panel features simple controls for easy operation and system monitoring.

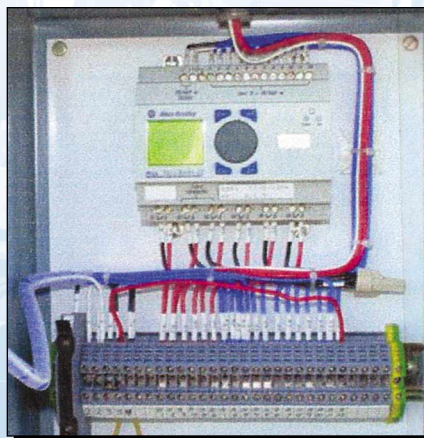

System PLC is designed to allow flexibility in C&C applications. It monitors dust accumulation and operates the conveyor only as needed to save energy.



CycloLok® Dense Phase Conveyor is ruggedly built to convey even the most abrasive materials using only plant compressed air.

C&C Reclaim System Specifications and Operation

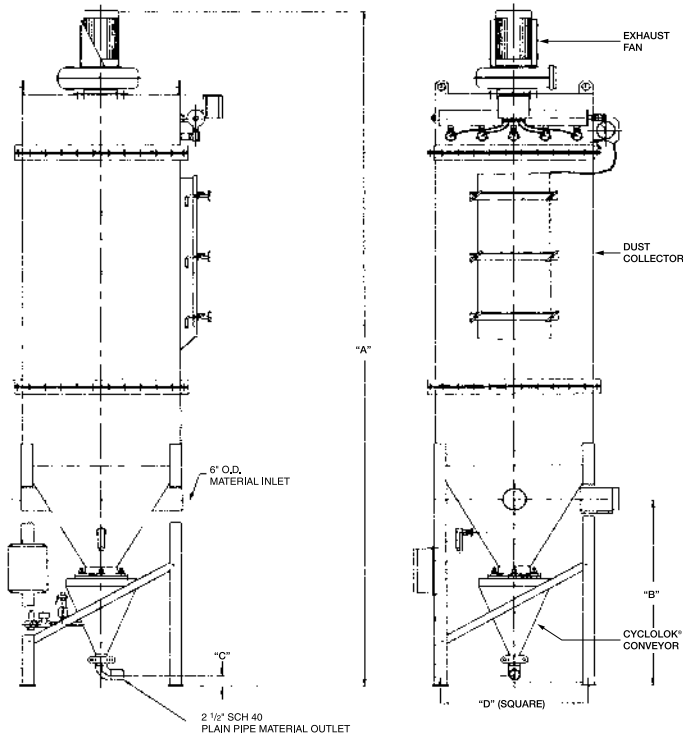
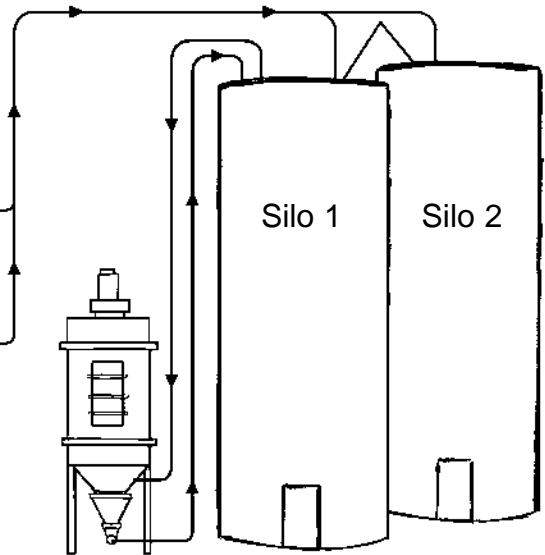
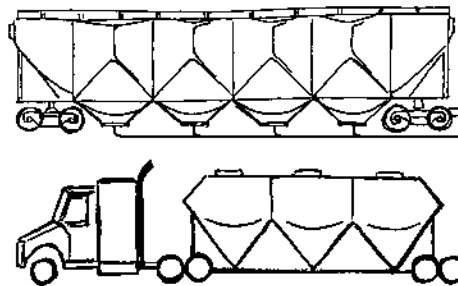
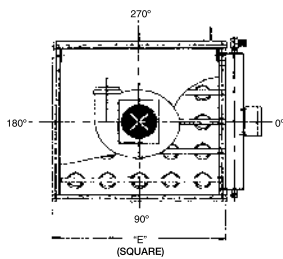

During silo loading, the exhaust fan draws particle-laden air from the silo into the dust collector, where reduced air velocity allows larger particles to fall into the collection hopper. Finer particles are drawn to the bag-type filter media. Timed reverse-air pulses discharge this dust into the hopper. When sufficient material fills the hopper, a high-level sensor automatically activates the CycloLok® Dense Phase Conveyor. Air entering the CycloLok moves the captured material through the convey system, returning it to the source silo or other destination. To minimize air supply usage, preset timers control the duration of the convey cycle. The entire process of cleaning bags and conveying reclaimed dust is controlled automatically by an on-board PLC, which triggers an alarm if service or maintenance is required.

Model	Filter Area sq. ft.	Fan scfm	A	B	C	D	E	Wt. lbs.
C&C 16	171	855	15'-0"	51"	3"	33"	36"	1630
C&C 25	265	1275	15'-5"	51"	3"	41"	44"	1800
C&C 36	382	1810	15'-10"	51"	3"	49"	52"	1970



2922 North Division Ave. 800-445-0730 Toll Free
 PO Box 366 402-362-2000 Phone
 York, NE 68467-0366 402-362-2001 FAX
 sales@cyclonaire.com E-mail
 www.cyclonaire.com