

VALCOM ONE-WAY PAGING SYSTEM DESIGN/INFORMATION

GENERAL

These instructions provide the basic information required to properly install a One-Way paging system manufactured by Valcom, Inc.

Valcom One-Way Paging Equipment may be used with any 1A2, Electronic Key, PABX Telephone Systems, or with one or more dedicated single line telephone sets.

SYSTEM OVERVIEW

Purpose

Provides telephone accessed single or multizone paging.

Applications

- Electronic Key Systems
- PABX
- Stand alone systems
- 1A2

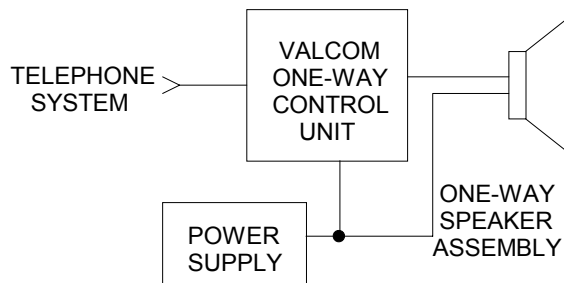

ONE-WAY PAGING SYSTEM BLOCK DIAGRAM
FIGURE 1

Features

- 1, 3, 6, 9, and 24 (expandable with V-2925A in 24 zone increments for up to 96) zone page control units available.
- One-way all call to all speakers available.
- Volume controls and amplifiers in each speaker.
- No high power amplifier required.
- Standard CAT 3, 5, 5E twisted pair cable (typically 22 or 24 AWG) is used for speakers.
- Existing twisted pair house cables / feed cables may be used without introducing crosstalk.
- See Multi-Path Information for systems up to 360 zones.

Access Methods

- Electronic Key System line button (C. O. circuit required).
- PABX loop trunk port (trunk circuit required).
- Page port.
- Station level access available (with appropriate adapter).
- Stand alone with dedicated single line sets.
- 1A2 line button (line card required on most units).

Capacity

- All units are one talkpath and one link.
- V-1094A, 1 zone (page port access only).
- V-2000A, 1 zone with an integrated power supply.
- V-2001A, 1 zone with an integrated power supply, override capabilities and featuring two integrated tone generators for night ringing and time clock tones.
- V-2003A, 3 zones with all call, background music capabilities, override capabilities, two integrated tones for night ringing and time clock signaling plus integrated power supply.
- V-2006A, 6 zones with all call, up to 3 group calls, override capabilities, background music capabilities, two integrated tone generators for night ringing and time clock tones plus integrated power supply.
- V-2924A, 24 zones with all call, background music capabilities.
- V-1109RTVA, 9 zones with all call.

Each of the units listed above will drive up to 40 Valcom one-way amplified speaker assemblies per zone (150 on V-1094A, V-9937, V-1101A, V-2000A, V-2001A, V-2003A and V-2006A). Additional speakers may be added to a zone by using a V-1094A. Each V-1094A allows the addition of 150 more amplified speaker assemblies to that zone.

VoIP (Voice-over-Internet-Protocol) Adapters

- Valcom's VoIP adapters provide loudspeaker paging through the client's LAN/WAN.
- VIP-800, Networked Audio Port, enables voice access over an IP-based LAN/WAN. Other VIP-800(s) will allow page zone extensions anywhere else on the network.
- VIP-810, Networked Station Port, connects to an FXO port, loop start trunk port, or dedicated analog telephone terminal device, and is connected to an IP-based LAN/WAN.
- VIP-820, Networked Trunk Port, allows a PBX system device or IP telephone adapter to be connected to a managed IP-based LAN/WAN. The PBX system device or IP telephone adapter must provide an open loop disconnect signal.
- UP to 99 zones are possible using a VIP-800 unit per zone for audio output.

Dimensions

V-1094A:	4.44"H x 2.75"W x 2.88"D (11.28cm x 6.99cm x 7.32cm)
V-2000A:	7.75"H x 5.8"W x 2.6"D (19.69cm x 14.73cm x 6.6cm)
V-2001A:	7.09"H x 9.0"W x 2.4"D (18.0cm x 22.86cm x 6.1cm)
V-2003A:	7.13"H x 10.00"W x 3.00"D (18.1cm x 25.4cm x 7.62cm)
V-2006A:	10.9"H x 13.00"W x 2.69"D (27.7cm x 33.0cm x 6.83cm)
V-2924A:	17.5"H x 10.3"W x 3.06"D (44.45cm x 26.26cm x 7.77cm)
V-2925A:	17.5"H x 8.37"W x 3.06"D (44.45cm x 21.26cm x 7.77cm)
V-2926:	5.3"H x 3.0"W x 1.1"D (13.46cm x 7.62cm x 2.79cm)
V-2928:	5.3"H x 3.0"W x 1.1"D (13.46cm x 7.62cm x 2.79cm)
V-1109RTVA:	7.13"H x 5.9"W x 2.13"D (18.11cm x 14.99cm x 5.41cm)
VIP-800:	1.88"H x 5.50"W x 4.15"D (4.78cm x 13.97cm x 10.54cm)
VIP-810:	1.88"H x 5.50"W x 4.15"D (4.78cm x 13.97cm x 10.54cm)
VIP-820:	1.88"H x 5.50"W x 4.15"D (4.78cm x 13.97cm x 10.54cm)

Environment

Control Units:
 Temperature 0 to +40 degrees C
 Humidity 0-85% non-precipitating

Inside Speakers:
 Temperature -20 to +55 degrees C
 Humidity 0-95% non-Precipitating

Horn Speakers:
 Temperature -20 to +55 degrees C
 Humidity 0-95% non-precipitating

Control Unit Power Requirements

Control Unit	"A" Battery	"B" Battery	VPU
V-1094A	-	50 mA	-1
V-1101A	50 mA	100 mA	-3
V-2000A	Supplies 600 milliamps, filtered		+12
V-2001A	Supplies 1 Amp, filtered		+20
V-2003A	Supplies 1.Amp, filtered		+20
V-2006A	Supplies 1.5 Amp, filtered		+30
V-2924A/V-2925A	A. C. Line Powered		0
V-1109RTVA	60 mA	250 mA	-6
VIP- 800/810/820	Power Supply Included		0

Notes for Table 1:

"A" Battery: -21.5 to -26VDC filtered "talk" battery

"B" Battery: -21.5 to -25VDC unfiltered "signal" battery

Filtered "A" battery may be used as both "A" battery and "B" battery.

Unfiltered "B" battery may not be used in place of filtered "A" battery.

VPU = Valcom Power Unit.

Speaker Power Requirements

Speaker	Power Requirements	VPU
V-1010C, V-1011MR, V-1012BB, V-1012MR, V-1013B-BK, V-1013B-W, V-1013B-GY V-1016-BK, V-1016-W V-1020C, V-1020KNOB, V-763-BK, V-763-W V-1021C, V-1022C, V-1023C, V-1024C, V-1025C, V-1026C, V-1027C, V-1042-BK, V-1042-W, V-1042-BR, V-1042-GY, V-1220, V-1222, V-9010-W, V-9021, V-9022, V-9028	45 ma, -24VDC	-1
V-1014B-BK, V-1014B-W, V-1014B-GY, V-1015B-W, V-1015B-BK, V-1015B-GY, V-1440-BK, V-1440-W, V-1440-BR, V-1440-GY	300 mA, -24VDC	-6
V-1030C/V-1030M	300 mA, -24VDC	-6
V-1036C/V-1036M	900 mA, -24VDC	-18
V-1038	1 Amp, -48VDC	N/A
V-1039A	1 Amp, -24VDC	-20
V-1050C	300 mA -24VDC	-6
V-1080-BG, V-1080-GY, V-1080-W	150MA - 24VDC	-3
V-1420	200 mA -24VDC	-4
V-1450	200 mA -24VDC	-4

VPU - Valcom Power Unit

One-Way Self-Amplified Speaker Styles

4" Ceiling Speaker	V-1010C
4" Recessed Ceiling Speaker (with mounting ring & support rails)	V-1011MR
8" Recessed Ceiling Speaker (with backbox & support rails)	V-1012BB
Black Track Style Speaker (1 watt version)	V-1013B-BK
White Track Style Speaker (1 watt version)	V-1013B-W
Gray Track Style Speaker (1 watt version)	V-1013B-GY
Black Track Style Speaker (5 watt version)	V-1014B-BK
White Track Style Speaker (5 watt version)	V-1014B-W
Gray Track Style Speaker (5 watt version)	V-1014B-GY
Black Pendant Speaker	V-1015B-BK
White Pendant Speaker	V-1015B-W
Gray Pendant Speaker	V-1015B-GY
Wall Speaker (black vinyl cover)	V-1016-BK
Wall Speaker (white vinyl cover)	V-1016-W
8" Ceiling Speaker	V-1020C
8" Ceiling Speaker with knob	V-1020KNOB
8" Ceiling Speaker with plastic grille	V-1021C
Wall Speaker (lt. brown open weave grille)	V-1022C
Wall Speaker (dark brown cloth grille)	V-1023C
Corner Speaker (lt. brown open weave grille)	V-1024C
Corner Speaker (dark brown cloth grille)	V-1025C
Bi-directional Corridor Speaker (lt. brown open weave grille)	V-1026C
Bi-directional Corridor Speaker (dark brown cloth grille)	V-1027C
Black Slimline Amplified Wall Speaker	V-1042-BK
White Slimline Amplified Wall Speaker	V-1042-W
Brown Slimline Amplified Wall Speaker	V-1042-BR
Gray Slimline Amplified Wall Speaker	V-1042-GY
Black Desk Top Speaker	V-763-BK
White Desk Top Speaker	V-763-W
5 Watt Horn	V-1030C
5 Watt Marine Horn	V-1030M
15 Watt Horn	V-1036C
15 Watt Marine Horn	V-1036M
30 Watt Horn	V-1038
7 Watt Explosion-Proof Horn	V-1039A
5 Watt Bi-directional Horn	V-1050C
Beige Flex Horn	V-1080-BG
Gray Flex Horn	V-1080-GY
White Flex Horn	V-1080-W
8" Dual Input Ceiling Speaker	V-1220
Dual Input Wall Speaker	V-1222
Signature Series Ceiling Speaker	V-1420
Black Signature Series Monitor Speaker	V-1440-BK
White Signature Series Monitor Speaker	V-1440-W
Brown Signature Series Monitor Speaker	V-1440-BR
Gray Signature Series Monitor Speaker	V-1440-GY
Signature Series In-Wall Speaker	V-1450
Surface Mount Vandal Resistant Speaker	V-9010-W
2' x 1' Lay-In Ceiling Speaker	V-9021
2' x 2' Lay-In Ceiling Speaker	V-9022
2' x 2' Dual Input Lay-In Ceiling Speaker	V-99028

SYSTEM DESIGN

1A2, Dedicated Single Line Set, E-Key, or PABX Paging

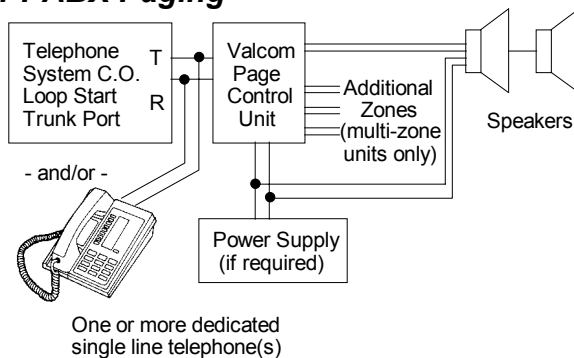

DIAGRAM 1

Block Diagram of Loop Start Trunk Port and/or Single Line Telephone Access of a Valcom Page Control/Interface

To provide one-way paging on 1A2, E-Key PABX Systems, or from one or more dedicated single line telephones, you will need a page control unit, one-way amplified speaker assemblies, and possibly a power supply. In most cases, page access will be via a line button for 1A2, a loop trunk port for a PABX or Electronic Key or via Tip and Ring on a single line telephone(s).

The control units may be any of the following.

1 zone	V-2000A
1 zone	V-2001A
3 zones w/all call	V-2003A
6 zones w/all call	V-2006A
9 zones w/all call	V-1109RTVA
24 zones w/all call*	V-2924A
*24 zone expansion module (up to 96 total)	V-2925A

The speakers may be any of those listed in Table 3 or any other Valcom amplified speaker or horn.

After you have selected the page control/interface and the quantity and type of speakers for your system, use Tables 1 and 2 to determine system power.

Add up the total Valcom power units (VPU) that will be required. Subtract any power units being provided by page controls featuring integrated power (2000 Series).

The remaining number of power units required will determine the quantity and model(s) of power supply required. Reference the next section, "Valcom Power Units".

Valcom Power Units

Each page control/interface, speaker and peripheral device has been assigned a Valcom power unit (VPU) value. Products that provide power, such as the 2000 Series page control/interfaces or power supplies, have power unit values indicated with a plus (+) sign. Products that consume power have power unit values indicated with a minus (-) sign. Products that neither require nor provide power are indicated by a VPU of zero (0).

After you have chosen the page control interface, speakers and accessories for your application, simply add up all of the Valcom power units [indicated by a minus (-)] for each item that requires power. This total tells you how much power you need. If you have chosen a 2000 Series control/interface, subtract the total power units provided by this controller from your previous total. If you come out even, or you have power left over, your paging system is complete. However, if you come out with more VPUs required than provided, you will need additional power.

The additional power required will be provided by adding one or more VALCOM power supplies as listed in Table 4.

Table 4 - Valcom Power Supplies

Part #	Voltage	Maximum Current	Valcom Power Units
VP-324	-24VDC	250 ma.	+6
VP-624B	-24VDC	600 ma.	+12
VP-1124	-24VDC	1 amp	+20
VP-2024	-24VDC	2.0 amp	+40
VP-2124A	-24VDC	2.0 amp	+40
VP-4024C	-24VDC	4.0 amp	+80
VP-4124	-24VDC	4.0 amp	+80
VP-6124	-24VDC	6.0 amp	+120
VP-12124	-24VDC	12 amp	+180
VP-2048C	-48VDC	2 amp	N/A
VP-412A	-12VDC	400 ma	N/A

There are several cases when more than one power supply will be required:

1. When the power required exceeds the maximum output of the power supplies available: Add additional supplies as required.
2. In large systems or systems with many horn speakers: Locate separate power supplies near groups of speakers. (Refer to Tables 8 and 10 for guidelines concerning maximum allowable distances for power runs.)

- When the paging system is in several buildings or on several floors of a single building, locate power supply in each building or on each floor being paged.

E-Key or PABX Page Port Access

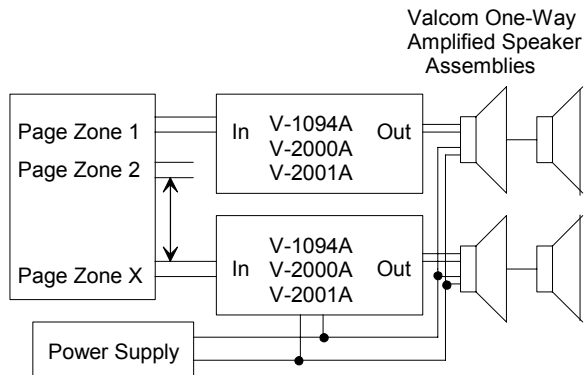

DIAGRAM 2
Block Diagram of Multiple Zones of One-Way Paging From Multiple Telephone System Page Ports

The Valcom V-1094A, V-2000A or V-2001A control units may be used for page port access to Valcom paging. Each of these units provide one zone of one-way paging. If more than one page port is available a V-1094A, V-2000A or V-2001A may be used on each port for multizone paging. Refer to Tables 2 and 3. For help in speaker and power supply selection refer to the section titled "IA2, Dedicated Single Line Set, E-Key, or PABX Paging".

NOTE: Generally, Valcom dial select multizone page units may not be used on page port output. (The V-2003A and V-2006A may be used on certain page ports).

Station level Paging

The Valcom V-9940 and V-9970 Station level Page Adapters may be utilized to provide access to a single or multiple zone paging system via an incoming central office line, Centrex//Essex line or PABX station.

This device.

- Accepts a ringing phone line or station port.
- Answers that line.
- Provides line level audio to the paging system.

For a single zone of paging, Valcom One-way Amplified Speakers may be directly connected to the audio output of the station level page adapter.

Electrically, station level page adapters act like a "self-answering" telephone.

The V-9940 and V-9970 are FCC registered for direct connection to the public telephone network, and also carry U.L. 1459 approval. It will ring trip from 70 to 105 VRMS (20 to 30 hertz) ringing voltage.

With a single line telephone, the called party provides the disconnect at the end of the conversation by going "on hook". A station level page adapter, on the other hand, has no way of "knowing" when the calling party has finished speaking. This unit has to sense line conditions in order to determine when it is time to disconnect.

With the V-9940 and V-9970, this line condition may be quiet line sensing, a strict "time out" (disconnects after a selected period of time) or open loop disconnect of at least 150 milliseconds. Open loop is a service provided by the central telephone office and involves actually disconnecting the telephone line from the C. O. for a brief instant. In some cases the "quiet line" may also be programmed via the PABX. "Quiet line" implies that the PABX will not return any tones (dial tone, busy tone, reorder tone . . . etc.) to the called station at the completion of the station to station call. The telephone system may be tested for a "no returned tones" status with your test set; have someone call you on a station and then ask them to hang up . . . if you do not hear any tones, or if there is a delay of at least 10 seconds before you hear any tones, then the "quiet line" (i.e. audio sense time-out) may be used.

Ground start telephone lines are a good choice for use with the V-9940 since a ground start line will not return dial tone until a ground is applied to the ring lead.

Additionally, the V-9970 recognizes re-order tones and dial tone as disconnect signals.

The V-9940 can be used alone, or can provide access to Valcom multi-zone and talkback page control units.

The V-9970 may be used to access the V-2003A and V-2006A multi-zone control units only. The V-9970 is not compatible with any talkback page control units.

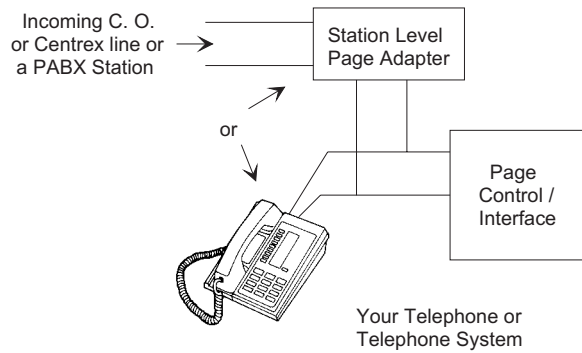

DIAGRAM 3
Block Diagram of Connections to a Valcom
Page Control/Interface

SYSTEM INSTALLATION

General

These instructions will provide a basic understanding for wiring Valcom one-way paging equipment and connecting it to a telephone system.

For specific wiring information, consult the installation practice enclosed with the actual equipment being used.

Precautions

Do not locate Valcom equipment or cabling within 18" of a power supply, electrical panel, or any equipment that generates electrical noise.

Mounting

The control equipment should be installed at the main distribution frame with the telephone system common equipment.

The V-1109RTVA, may be mounted to the backboard, in a 7" KTU rack or mounting frames. A 66-type and 25-pair pigtail with female amphenol connector are required for connections to these units if the mounting frames are not used. Other control units are wall mount units with connections via either screw terminals, integrated punch down block, or a user supplied 66-type block.

Speaker Spacing

Ceiling Speakers: The area covered by a ceiling speaker depends on the height of the ceiling. Refer to Table 5 for speaker coverage.

Wall Speakers: A wall speaker will cover up to 600 square feet. Wall speakers should be spaced 20 feet apart. Good quality paging will be heard up to 30 ft. in front of the speaker.

Corridor Speakers: Corridor speakers should be mounted 8 to 12 feet high and spaced 30 to 40 feet apart.

Horn Speakers: Refer to Table 6 for horn speaker coverage. The first figure given is the side to side distance between the speakers. It is also the distance in front of the speaker that you can expect to hear a good quality page. The second figure given is the area being covered in square feet.

Track Style Speakers:

The 1 watt version will cover an area up to 600 sq. feet. These speakers should be spaced approximately 20 feet apart. Good quality page audio will be heard up to 30 feet in front of the speaker.

The 5 watt version will cover up to 3,600 sq. feet. Depending upon the height of the installed speaker, good quality paging will be heard up to 60 ft. in front of the speaker.

Pendant Speaker: The area covered by a pendant speaker is determined by the mounting height. Refer to Table 5 for speaker coverage.

Table 5 - Ceiling Height Spacing/Coverage

Ceiling Height (ft.)	≤ 8	10	12	15	25
Spacing (ft.)	16	20	25	30	35
Approximate Coverage (ft ²)	250	350	500	800	1000
Wall Speakers: One per 600 sq. ft. spaced 20 ft. apart					
Corridor Speakers (bi-directional): Spaced 35 ft. apart					

Table 6 - Horn Spacing/Coverage

Location	5 Watt	15 Watt	30 Watt
Quiet 50-65db	110' (12,000ft ²)	N/A	N/A
Moderate 65-80Db	80' (6,400ft ²)	N/A	N/A
Noisy 80-90dB	50' (2,500ft ²)	75' (5,600ft ²)	N/A
Very Noisy 90+dB	30' (900ft ²)	45' (2,000ft ²)	60' (3,600ft ²)

*Contact Valcom Technical Support

Noise Level Definitions

Quiet: 50-65dB. This would include areas such as waiting rooms or doctors' examination rooms.

Moderate: 65-80dB. This includes areas such as warehouses, shipping areas, or light manufacturing.

Noisy: 80-90dB. This includes machine shops or heavy manufacturing.

Very Noisy: Greater than 90dB. This would include areas where talking to another person is very difficult. Workers may be required to wear earplugs.

NOTE 1: *In areas the sound level exceeds 100dB, consideration should be given to using a code call unit (V-9923B) for tone signaling instead of using voice paging. In extreme ambient noise, it is generally easier to identify a tone code than to discern speech.*

NOTE 2: *Reverberant Areas - To increase the intelligibility of paging in reverberant areas, horns should be mounted closer to the people being paged, in effect, mounted at a lower height, closer together and angled towards the floor.*

Speaker Cabling

All Valcom one-way amplified speakers require 2 pairs to operate. Standard CAT 3/5/5E/6 telecom/ data cable may be used. Existing telephone wire and feed cables may also be used. Refer to Tables 7 and 8 when planning a job.

Audio pair: The number of speakers looped on the audio pair is not critical unless you have a very large job. Table 7 gives guidelines for the number of speakers per audio run.

Power Pair: The cable runs specified in Table 8 are very important and *MUST* be followed for proper operation of the one-way paging speakers.

Table 7 - Number of Speakers/Horns per Audio Run

Wire Run (Ft.)	22 AWG	24 AWG
100	150	120
200	150	120
400	100	60
800	50	30
1600	25	15

Table 8 - Number of Speakers per Power Run
(CAT 3/5/5E/6, 22 & 24 AWG)

Quantity of Speakers/Horns				Maximum Wire Run Distance (Ft)	
1 Watt Interior Speakers	Signature Series	5W	15W 30W	24 AWG	22 AWG
4	1	-	-	1000	1600
7	2	1	-	500	800
15	4	2	-	250	400
30	8	4	1	125	200

Bridges and Backboxes

Ceiling speaker bridges provide support to prevent ceiling tile from sagging from the weight of the speaker. They are designed for use with standard 2' wide ceiling tiles and distribute the weight of the speaker assembly across the tile and onto the tile support grid.

Ceiling speaker backboxes provide an acoustic enclosure behind the speaker for better sound quality. They also protect the speaker from debris in the ceiling and meet most local fire codes for use in air plenum return ceilings. See Table 9 for Speaker and Bridge/Backbox compatibility.

Volume Adjustments

Master volume controls are located on most Valcom page control units. Each one-way speaker assembly also has its own volume control. When installing a system, set the master control to 1/2 and all speaker and horn volume controls to 1/2 volume. After powering up the system, adjust the individual speakers to the desired level.

The master control may then be used to change the volume of the entire system. If background music is being supplied, the background music level should be adjusted last. To provide volume control to a certain room or area, V-1092 Wall Mount Volume Controls may be added to a zone, or to a section of a zone.

SYSTEM OPERATION

Circuit Description

Each Valcom page control unit contains the circuitry required to interface with a telephone system, plus a preamplifier circuit, and in some cases dial select circuitry and/or provisions for background music switching. Each one-way amplified speaker assembly contains a speaker, amplifier, and volume control in a suitable baffle or housing. The speakers and control units require a -24VDC power supply (-48VDC for the V-1038) to operate.

Connections from the control unit to the telephone system are described in detail in the manual that is shipped with the control unit.

The audio pair from the control unit to the speakers may be looped (speakers wired in parallel) between all speakers in a zone (See Table 7). A second pair must be run to each speaker to supply the DC voltage required for operation (See Table 11). Standard 22 or 24AWG telephone cable may be used for the speakers.

When accessing a single zone control unit from the telephone system, you will immediately be connected to the speakers and allowed to page.

When accessing a multizone control unit from the telephone system, you will receive Valcom dial tone from the Valcom unit. After dialing the code for the zone desired, you will be connected to that group of speakers and allowed to page. All Valcom control units automatically release when you hang up the telephone.

TECHNICAL ASSISTANCE

Refer to the installation practices for the equipment being used for troubleshooting information and procedures. Assistance in troubleshooting is available from the factory. Call (540) 563-2000 and press 1 for Technical Support.

Valcom equipment is not field repairable. Valcom, Inc. maintains service facilities in Roanoke, VA. Should repairs be necessary, attach a tag to the unit clearly stating company name, address, phone number, contact person, and nature of the problem. Send the unit to:

Valcom, Inc.
Repair & Return Dept.
5614 Hollins Road
Roanoke, VA 24019-5056

PROBLEM SOLVERS

Automatic Volume Control

The V-9933A Noise Sensing Volume Control monitors the noise level fluctuations in an area by utilizing a built-in microphone. When a page is made, the V-9933A electronically locks onto the last noise level sampled and automatically adjust the volume of up to 150 Valcom One-Way Self-Amplified Speakers in order to compensate for the current ambient noise level, thus eliminating the need for personnel to manually adjust the paging speakers. The V-9933A should be mounted in the area that experiences the fluctuating noise. If a single zone contains areas of independently fluctuating noise levels, multiple V-9933A units may be used (one per area).

- Each Noise Sensing Volume Control, V-9933A, can control up to 150 amplified speakers or horns in a single zone.
- Multiple Noise Sensing Volume Controls, V-9933A, can be used on the same zone if desired.
- V-9933A can be connected to a zone output of any Valcom One-Way Page Control/Interface or Station Level Page Control.
- Not for use with background music without additional equipment.

Remote Microphone

The V-9934 Remote Microphone may be used with the V-9933A Noise Sensing Volume Control.

- V-9934 is a self-contained microphone and pre-amp.
- No power supply is required for V-9934
- Up to four v-9934 units may be paralleled on one V-9933A.
- Each V-9934 may be on a 1000' wire run.

Stacking Feedback Eliminator

The V-9964, Stacking Feedback Eliminator, is designed to prevent paging system feedback. When a page is made into a zone, the V-9964 records the page into digital memory. Upon completion of the live page, the message is released to play over the zone of speakers. Since the paging party has hung up the telephone or released the microphone, offensive feedback cannot occur.

- Each Stacking Feedback Eliminator, V-9964, can control up to 150 amplified speakers or horns in a single zone.
- Multiple Stacking Feedback Eliminators, V-9964, can be used on multiple zone page controls.
- The V-9964 can be connected to a zone output of any Valcom One-Way Page Control/Interface or Station Level Page Control.

ENHANCEMENT TO EXISTING 25/70/100 VOLT PAGING SYSTEMS

Using a Valcom Page Control/Interface with a Central Amplifier

Typically a zone from a one-way control unit may be directly connected to a high power amplifier to allow access to existing paging equipment. In certain cases capacitors or a resistor network may be required to interface the Valcom equipment to the amplifier. Contact Valcom Technical Support if trouble is encountered.

NOTE: Not all Valcom page control units have control leads available for amplifier control. Use Valcom One-Way Self-Amplified Speakers to expand a 25/70/100V audio zone.

It is cost effective to expand a centrally amplified paging system with Valcom distributed amplified speakers. In many instances expanding a centrally amplified paging system involves replacement of the expensive central amplifier with a larger one in order to provide the additional power that the speakers or horns require.

This also involves additional labor in re-balancing the system. Adding high voltage type speakers to an existing amplifier where the load is not configured properly will cause distortion or premature system failure, again requiring replacement of the central amplifier. By using Valcom distributed amplified speakers to expand the system, almost unlimited growth is possible, without loading down the existing amplifier.

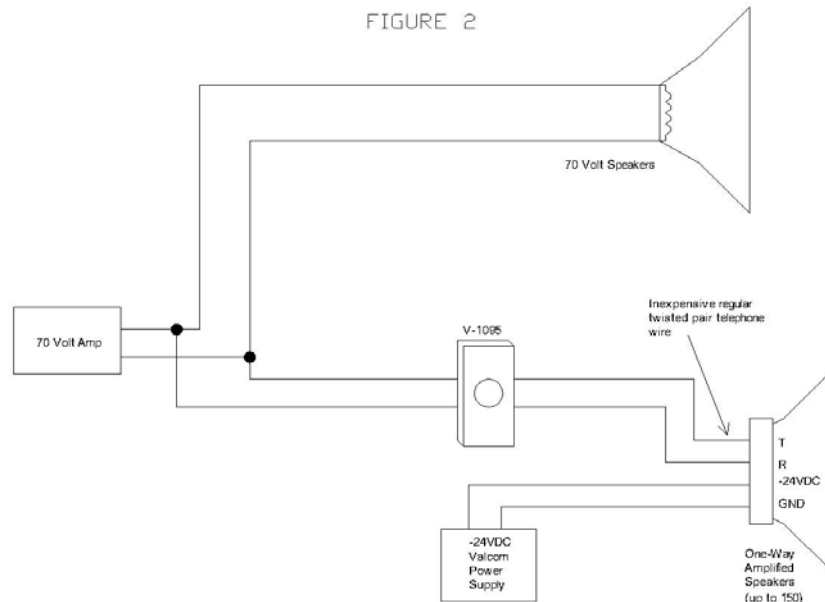

Using Valcom One-Way Amplified Speakers To Expand an Existing 70 Volt Paging System

ADVANTAGES OF DISTRIBUTED AMPLIFIED SYSTEMS

- Low voltage, therefore existing telephone cable (Class 2 wiring) can be used to eliminate costly outside plant or indoor conduit.
- Low voltage operation means much less power dissipation (heat), therefore the longevity of the paging equipment is increased dramatically.
- Multizone capability of 96 zones from a single trunk port. (Up to 576 Zones with All Call with multiple systems connected for Global All Call – Call Valcom Technical Support for assistance)
- Talkback, one-way or combination systems are easy to configure.
- Individual volume controls built-in to each one-way speaker for volume adjustment after system is installed.
- It is cost-effective to install one telephone cable versus installing both telephone cable and 70 volt shielded paging cable.
- Unlimited one-way speaker expansion since each speaker is self-amplified.
- Jobs requiring explosion-proof systems are easily accommodated.
- Amplified one-way speakers can interface 70 volt systems without changing or adding central amplifier.
- Many localities require conduit for "high voltage" (Class 1) conductors, this is rarely a necessity with a distributed amplified system.
- The rated output of a distributed amplified paging speaker or horn is always available due to the fact that the actual audio signal amplification is accomplished on an individual basis. In a 70 volt system, the rated output is only available if the central amplifier is actually providing a full 70 volts to the speaker or horn and the audio signal line losses are negligible.
- Background music is unaffected in zones that are not currently being paged.

Table 9

Ceiling Speaker	Support Ring	Bridge	Backbox	Bridge/Backbox Combo	Flamex®	Metal
V-1010C	-	V-9904M-5	V-9915M-5*	-	-	X
V-1020C, V-1220C	V-9912M-10 or V-9912P-12	- -	V-9915M-5 -	- -	X -	X -
V-1020C, V-1220C	- -	V-9914-5 Or V-9914M-5	V-9915-5* Or V-9915M-5	V-9916 Or V-9916M	X -	X -
V-1021C	V-9918	-	V-9915-5	-	-	-
V-1021C	-	V-9914-5	V-9915-5	V-9916	X	-
V-1420	-	-	-	V-9816M	-	X

The V-9914-5 Bridge and the V-9915-5 Backbox are made of Borg-Warner Flamex® fire retardant (94-0) material and may only be ordered in multiples of five (5).

The V-9904M-5, V-9914M-5, and V-9915M-5 metal bridges and backboxes may only be ordered in multiples of five (5).

*Must use corresponding bridge.

Table 10 – Valcom One-Way Page Control/Interface Feature Chart								
Model #	V-1094A	V-2000A	V-2001 A	V-2003A	V-2006A	V-1109RTVA	V-2924A/ V-2925A/V-2926	
Number of Zones	1	1	1	3	6	9	24 - 96	See The MultiPath Product Line For Up To 360 Zones
Power Units	-1	+12	+20	+20	+30	-6	0	
Background Music		X	X	X	X	X	X	
All Call				X	X	X	X	
Night Ringing Tones			X	X	X	Add V-9927A	X	
Time Clock Tones			X	X	X	Add V-9927A	X	
Power Supply Built In		X	X	X	X		X	
Group Call					X		X	
Battery Back-up Input			X	X	X		X	
Inhibit (Speaker Cancel)				X	X	X	X	
Loop Start Trunk Access		X	X	X	X	X	X	
Gnd Start Trunk Access				X	X			
Page Port Access	X	X	X	Note 1	Note 1		On Override Input	
1A2 Intercom Access								
Override Tip and Ring			X	X	X		X	

Note 1: Works on selected telephone system