

Media Distribution NetKey® Patch Panel

PANDUIT®

DATA SHEET

Modular patch panel shall consist of a metallic right-angle panel with snap-in faceplates which are removable from the front. Modular patch panel shall mount within an enclosure and shall accept all Net-Key® Modules to mix and match media as required. Modular patch panel shall also offer quick installation features for easy moves, adds, and changes.



technical information

Dimensions: 3.87"H x 2.99"W x 2.00"D (89.3mm x 96.5mm x 50.8mm)

Mounting: Snaps into 1" grid pattern of the enclosure

Packaging: Includes metal patch panel with assembled faceplate and mounting clips

Compliance: RoHS, TIA/EIA 570-B Residential Wiring Standard, cULus and UL

key features and benefits

Front-side removable faceplates Allows front access to installed modules for easy moves, adds, and changes

Modularity Accepts all Net-Key® Copper, Fiber, and Audio/Video Modules which provide the ability to add ports, mix and match media, and replace modules as needed

Snap-in installation Snaps directly onto 1" grid pattern to simplify installations and allow easy moves, adds, and changes

applications

The Panduit media distribution system is a complete structured cabling solution for residential and commercial deployments that cost-effectively delivers emerging communication and video entertainment connectivity into individual location enclosures. Using customizable hubs and patch panels installed within the enclosure, the media distribution system provides voice, video and data applications (commonly referred to as triple-play services) throughout a home or office. Modularity with Panduit products allows

the media distribution system to service an entire network infrastructure from the building demarcation point to the end user's network outlet.

The media distribution Net-Key® Modular Patch Panel provides a front-accessible patch panel module for use with interchangeable Net-Key® Category 5e and 6, Copper, Fiber, and Audio/Video Modules within an enclosure, offering the ability to add or replace modules as needed.

Accessories

NetKey® Modular Patch Panel:	NKM8PP
Equipment bracket:	MSEBRKT
Cable management ring:	MSCMR
Cable management kit:	MSCM-KIT
Grounding kit:	MSGRD-KIT

Enclosures

Advanced

14" base	MS14B
14" hinged door	MS14HD
24" base	MS24B
24" hinged door	MS24HD

(Base and hinged door sold separately.)

Basic

14" base with screw down door	MSB14E
24" base with screw down door	MSB24E

NetKey® Voice (Phone) Hubs

Distribution hub:	NKM8PD
Expansion hub:	NKM8PE

Video Splitters

1 x 8 passive 1GHz:	MS8S1G
1 x 4 passive 1GHz:	MS4S1G
1 x 8 passive 2GHz:	MS8S2G
1 x 4 passive 2GHz:	MS4S2G

NetKey® Data Hub

Category 5e data hub:	NKM5E6PP
------------------------------	----------

NetKey® Modules

Category 6

Jack Module:	NK688M**
F-Type Module:	NKF**
5-Way Binding Post (with black stripe):	NKBPB**Y
5-Way Binding Post (with red stripe):	NKBPR**Y

**For additional colors, substitute ** with IW (Off White), EI (Electric Ivory), WH (White), IG (International Gray), or BL (Black).

Media Distribution NetKey® Patch Panel

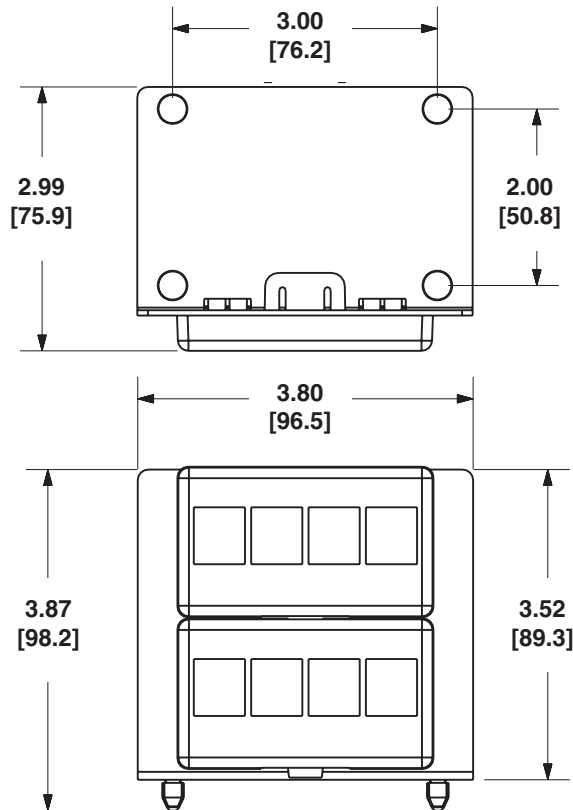
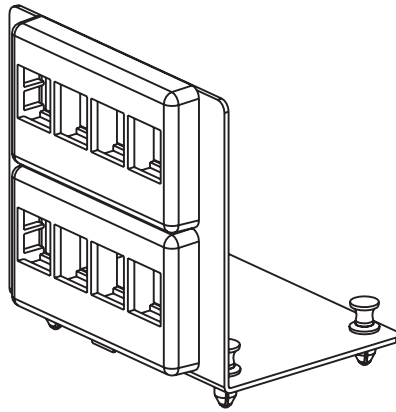

Dimensions are in inches [Dimensions in brackets are metric]