

## 25" Self-trimming Electric Firebox

DFG2562

### Product Description

- Patented electric flame technology
- Light shines and reflects off the asymmetrical-sized glass pieces creating an effect that is as alluring as it is contemporary
- On-demand heat with thermostat control
- Clean, self-trimming design – no separate trim required
- Year-round comfort - operates with flame only or flame and heat
- Contains removable plug for direct wire applications
- Safe, clean electric operation
- 120 Volts / 880 Watts / 3,000 BTU

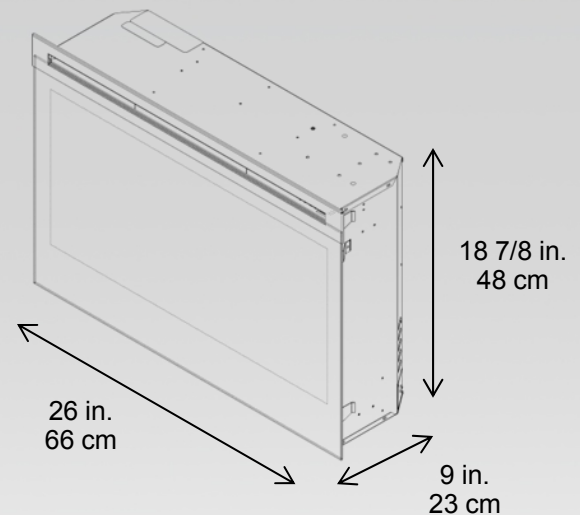
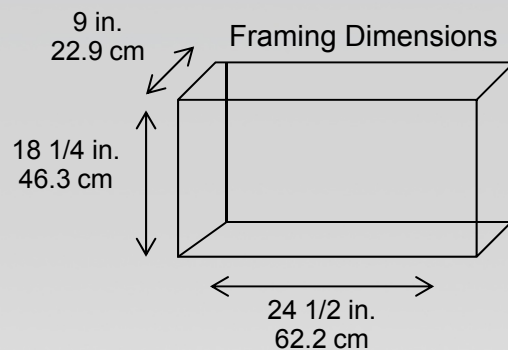

Includes on / off remote control



No carbon monoxide or emissions, glass stays cool-to-touch

Model #	Description	lbs/kg	UPC	Wty. †	Carton Dimensions (W x H x D)		Cube	
					Inches	cm	ft <sup>3</sup>	m <sup>3</sup>
DFG2562	25" Self-trimming widescreen electric firebox with glass ember bed.	39.6 / 18	781052 061552	2 yr.	29.6 x 23.4 x 12.9	5.2 x 59.4 x 32.8	5.2	0.15

Patent protected: for a complete list of applicable patents visit: [www.dimplex.com/patents](http://www.dimplex.com/patents). Specifications, finishes and dimensions are subject to change and should be taken as a guide only.

\* Based on average national residential electricity rates. Rates vary. † Limited warranty. © 2011 Dimplex North America Limited.