

# INSTALLATION GUIDE

Before installation make sure all power to the machine is switched off. Ensure that all residue such as dust and grease is wiped from the feeder drum using white spirit or similar cleaning substances.

The cover feeder clutch must be set in the out of drive mode to allow a forward motion of the drum to be manually turned during make ready.

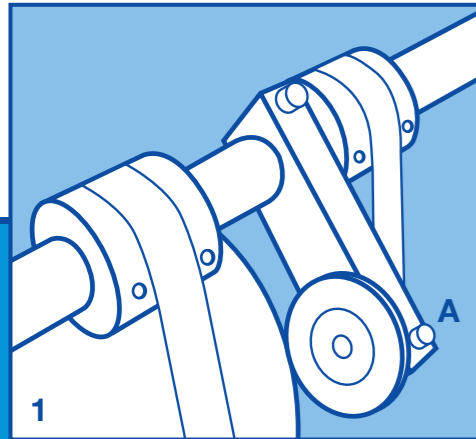

## Step 1 - Remove Old Device

Remove the creasing wheel (A) with a number 5mm hexagon key is located on the pressure creasing arm.

## Step 2

Unscrew the 3 x 10mm bolts (A) that hold the horseshoe creaser to the drum this is located in the centre of the cover feeder, the horseshoe should now be detached and hang loosely from the drum.

With the gripper and sucker bar facing towards the direction of the stitching heads the shoe needs to be rotated by hand in a clockwise direction so that it can easily be pulled free without getting stuck on any feeding mechanisms.

The new stainless steel horseshoe can now be fixed back onto the drum using the same method as the removal process.

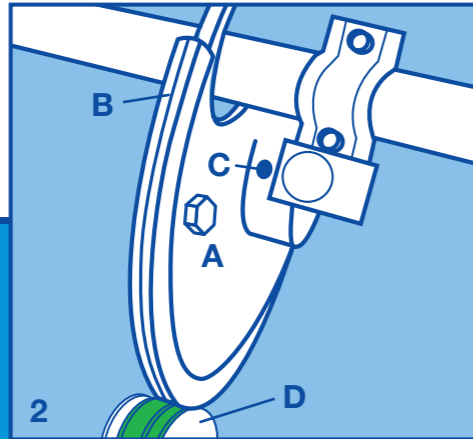

Choosing the male rubber creasing matrix which corresponds to the weight of the stock you are about to crease.

Orange dot creasing matrix (Mould No.24) = 80-135gsm

White dot creasing matrix (Mould No.23) = 135-250gsm

Yellow dot creasing matrix (Mould No.22) = 250-350gsm

Peel the backing strip away and apply the sticky side of the matrix into the recess. Starting at the opened gap (B) in the horseshoe (the paper stock creases after the first 25mm) push the matrix into the recess all round the drum and trim off any protruding excess with a sharp knife.

Centralise the horseshoe drum. This is achieved by loosening the 2 screws holding drum (C) on the main drive shaft. Gently push the drum sideways to centralise the matrix with the centre of the green recessed belt (D) this is located immediately after the horseshoe. When this has been achieved retighten the 2 drum fixing screws.

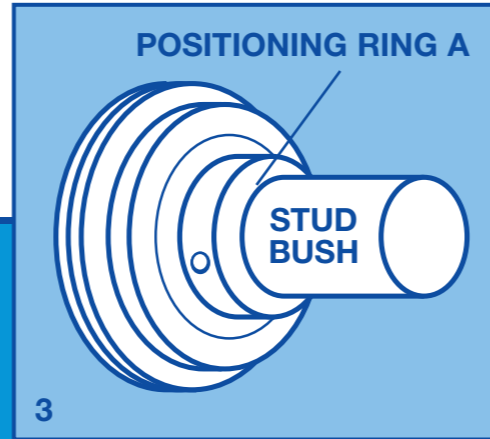

## Step 3 - Choosing the female channel width

Unscrew the hexagon screw located in the centre of the female. Gently push the female away from the stud shaft and replace the correct female channel width.

● Orange dot = Small 80-170gsm

● White dot = Medium 135-300gsm

● Yellow dot = Large 280-350gsm

## Diagram 1

### Attaching the female

Slide the stud through the 17mm opening on the creasing arm (A) and tighten with a No 5 hexagon key.

Push the desired female onto the special fitting stud bush and tighten with a No 5mm hexagon key.

Screw the No 5 hexagon key holding the stud in place.

Align the female into the centre of the black rubber matrix and tighten the No 5 hexagon key again.

The cover feeder is now ready for testing.

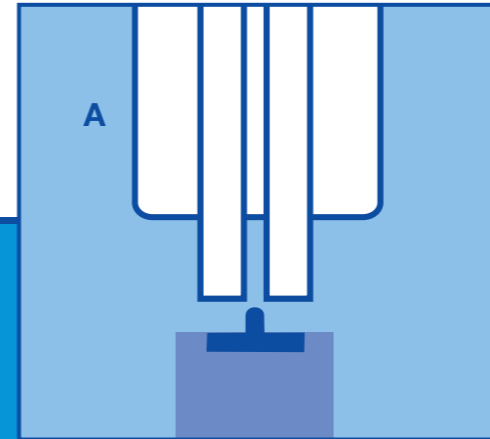

## Testing the cover feeder

Place a piece of stock cover into the grippers and turn the drum by hand so that the stock passes over the female. Remove the creased stock before it passes under the folding unit and check the crease quality. The crease should be giving a distinct even sided crease. If this is not correct the female should be moved slightly until a good even sided crease is formed.

It is important to remember that maximum results can only be achieved through central alignment of the female channel to the creasing matrix.

When this has been achieved push the positioning ring (A) on the stub shaft up to the creasing arm and lock in place using a No 2.5mm hexagon key.

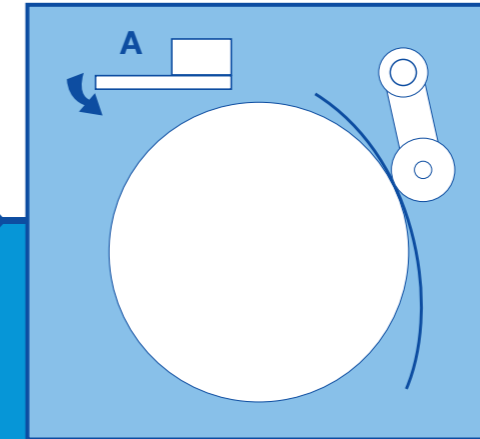

## Step 4 - Setting the calliper

Place the correct stock into the callipers and adjust until the optimum crease is obtained. The female should spin freely when there is no cover stock passing over the female.

**The Tech-ni-Fold Spine Creaser installation is now complete.**

## Installing a new matrix

When removing the old glue strip from the matrix it is important to remove all the clear plastic tape that is hidden inside the glue strip. Clean the old glue away using white spirit and dry off, rub the horseshoe recess with an abrasive brush to remove all traces of the spirit as this can dissolve the glue strip on the back of the new matrix.

### MATRIX CREASING GUIDE

There are three types of Matrix available to crease the full range of cover stock materials

- ORANGE = 100 - 135gsm
- WHITE = 135 - 250gsm
- YELLOW = 250 - 350gsm (Wide option)

### RE-USEABLE MATRIX

Each matrix can be carefully peeled off and re-used.

*We also provide creasing solutions for the following machines:*

#### Folding Machines

Stahl/Heidelberg  
MBO  
Herzog & Heymann  
GUK  
Horizon  
Shoei  
Bremmer  
Morgana  
MB  
Eurofold  
Rollem (scoring machines)  
Rosback (scoring machines)  
Multigraf (scoring machines)

#### Stitchers

Muller Martini  
Heidelberg  
Hohner  
Osako

#### Perfect Binders

Muller Martini  
Kolbus



Tech-ni-fold Ltd  
Unit 2  
St John's Business Park  
Lutterworth  
Leicester  
LE17 4HB  
Tel: +44 (0) 1455 554491  
Fax: +44 (0) 1455 554526  
Email: [info@technifold.co.uk](mailto:info@technifold.co.uk)  
Website: [www.technifold.com](http://www.technifold.com)

# SPINE - CREASER

**for ST-350  
ST-400  
ST-450**



**INSTALLATION GUIDE**