



UltimateAir, Inc.
178 Mill Street
Athens, Ohio 45701

Tel: 740-594-2277
Fax: 740-592-1499
www.ultimateair.com

2000DX Water-to-Air Coil *Instruction / Installation Guide*



2000DX Water-to-Air Coil Dimensions

Drawing below shows overall size of Water-to-Air Coil and the relative locations of the supply and return connections. Both plumbing connections are 1.25" MPT.

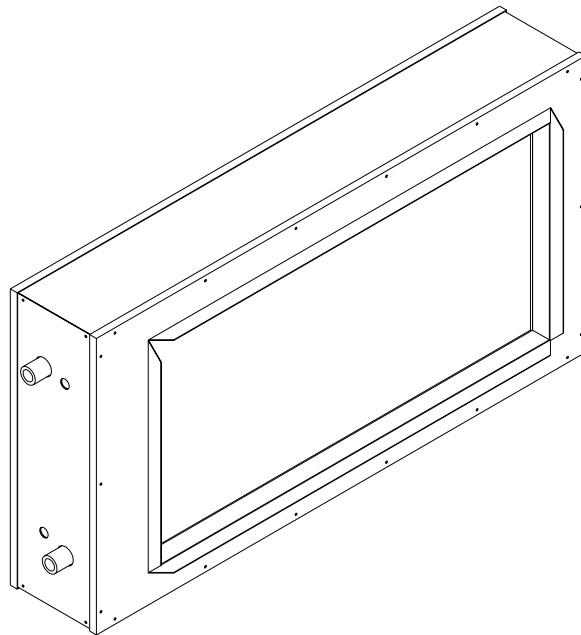
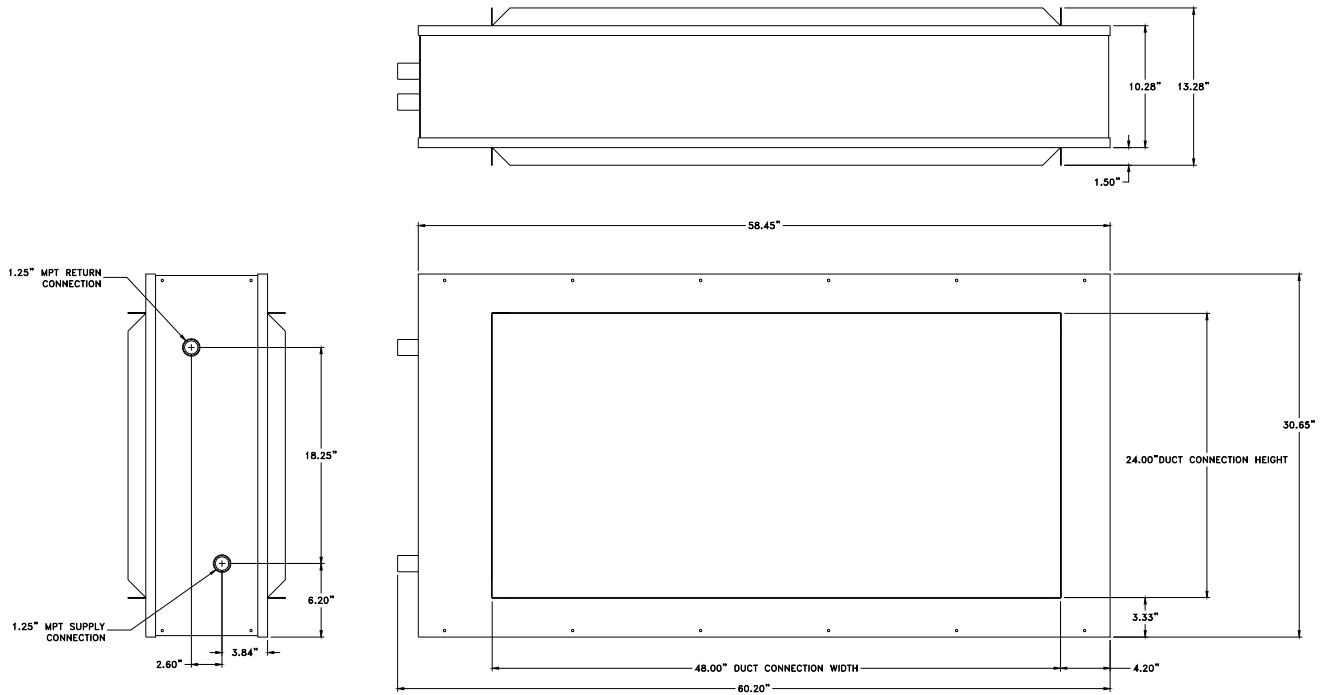

Performance Data:

Test	Inlet Water	Water Flow	Air Flow	Inlet Air	Inlet Air	Inlet Air	Outlet Water	Outlet Air		DP Fan <i>in.</i> <i>wg.</i>	Capacity Btu/Hr		
	<i>F</i>	<i>GPM</i>	<i>CFM</i>	<i>DB F</i>	<i>WB F</i>	<i>RH %</i>	<i>F</i>	<i>WB F</i>	<i>DB F</i>		<i>Total</i>	<i>Sensible</i>	<i>Latent</i>
Options For Pre Cooling and Dehumidifying													
1	60	2.0	500	95	85		76.6	65.3	64.7		16578	16578	0
2	60	6.0	500	95	85		76.2	61.3	61.6		49065	18561	30503
3	60	12.0	500	95	85		68.3	59.6	60.2		50385	19031	31354
4	60	2.0	1000	95	85		81.8	75.0	75.3		21627	21627	0
5	60	6.0	1000	95	85		82.6	70.5	70.6		66990	27188	39802
6	60	12.0	1000	95	85		73.8	65.8	66.4		82076	31357	50719
7	60	2.0	2000	95	85		86.5	80.2	82.9		26492	26492	0
8	60	6.0	2000	95	85		75.9	76.1	73.3		47643	47643	0
9	60	12.0	2000	95	85		79.7	72.3	72.7		117200	48886	68314
10	60	2.0	1500	95	85		85.0	78.3	79.9		24961	24961	0
11	60	12.0	1500	95	85		77.5	69.4	70.0		104207	41147	63060
12	60	6.0	1000	95	85		81.5	70.7	71.0		64663	26307	38356

Revised: Friday September 10, 2010