

RecoupAerator® 2000DX
Energy Recovery Ventilator

Owner's Manual & Installation



UltimateAir®

178 Mill Street
Athens, Ohio 45701
740.594.2277
ultimateair.com
info@ultimateair.com

Introduction

Thank you for your purchase of a RecoupAerator 2000DX, the most advanced energy recovery ventilation system available today! Your RecoupAerator 2000DX is designed to bring fresh, filtered air into your building while simultaneously exhausting stale air.

The 2000DX is an Energy Recovery Ventilator (ERV), meaning the RecoupAerator recovers and transfers air temperature and moisture from the stale outgoing air to the incoming fresh air. No matter what the season, you stay comfortable while breathing fresh clean air.

In addition to having an energy transfer rating of up to 95%, the RecoupAerator moderates indoor humidity in the winter and turns away outdoor humidity in the summer.

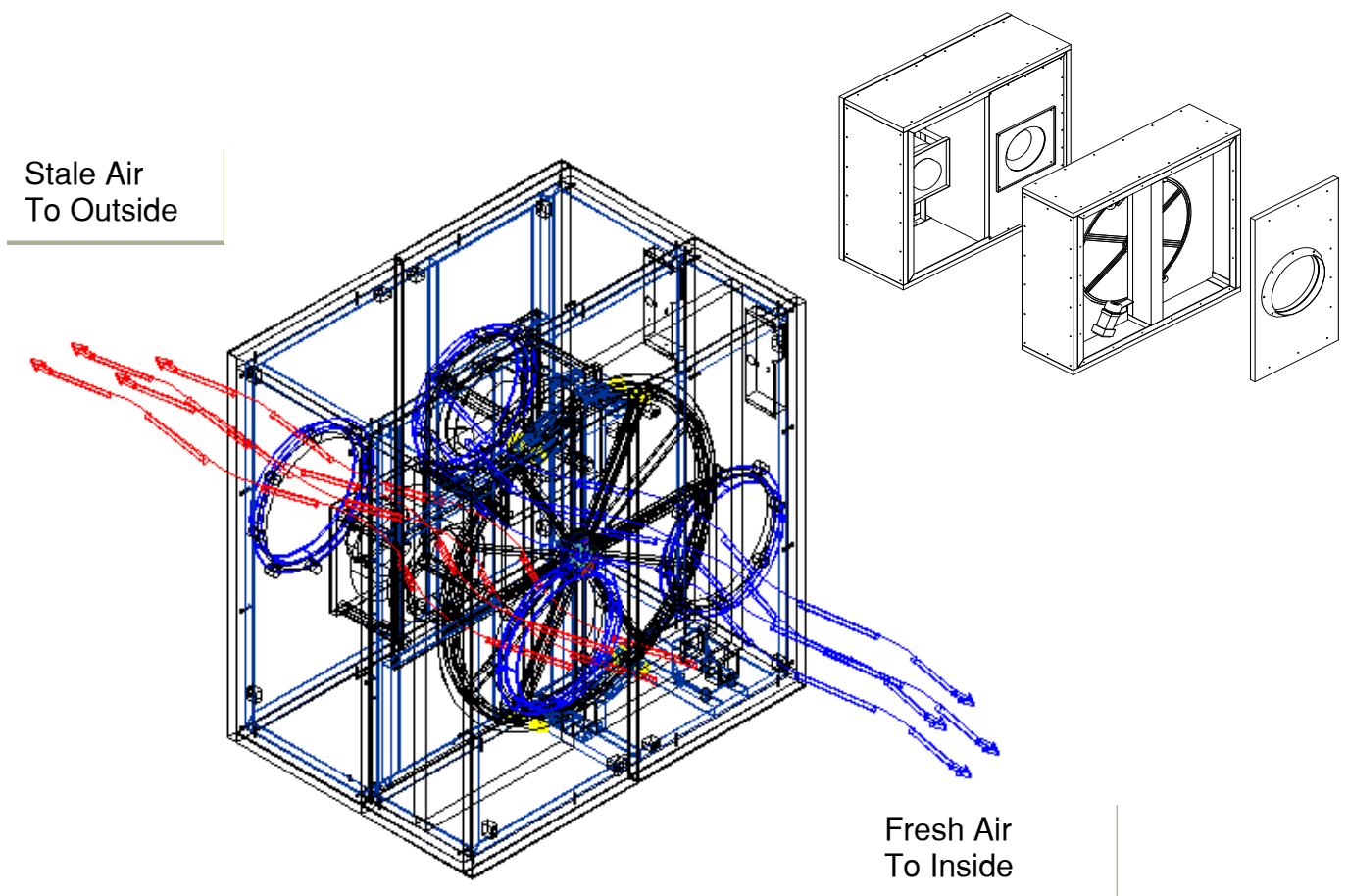

General Description

The RecoupAerator 2000DX is a modular unit with separate housings for the fans and heat recovery wheel. The Fan Housing contains the intake and exhaust fans and their associated controls while the Wheel Housing contains the heat recovery wheel and its respective drive components. The two housings are coupled via external draw latches and join with an airtight seal. The heat recovery wheel is made up of removable cartridge filter inserts which contain the heat recovery and filter material. The cartridge inserts allow the heat recovery and filter material to be easily removed and cleaned. Both housings sit on a vibration isolating rubber pad on the included base which has vibration dampening, adjustable height feet. The 2000DX controls are custom per installation.

The 2000DX has four 18" dia. duct connections. Please see illustrations contained in this manual. Both housings have removable doors at each duct connection for access to the interior for maintenance. All user performed maintenance will occur in the Wheel Housing. The Fan Housing contains no user adjustable or replaceable parts.

Features

- Patented random fiber matrix rotary energy recovery core
 - Stainless steel rotary wheel
 - Washable
 - Electronically commutated DC motor for efficient wheel speed control
- Backward curve electronically commutated DC motorized impellers (2)
- Variable air flow
- External electrical connection and low voltage controls
- Fully insulated housing
- Exterior powder coat/painted steel
- MERV 8-12 filtration



Options and Controls

- Economic cooling control
- CO2 based demand ventilation control
- Duct pressure/occupancy demand control
- Fully programmable flow controls

Part Descriptions

- Case:** 16 gauge baked powder coat sheet steel insulated with 1.5 inch EPS with flame retarder additive.
- Blowers:** Two maintenance free EBM backward inclined motorized ECDC impellers with permanently lubricated sealed ball bearings and thermal overload protection.
- Wheel motor:** Maintenance free ECDC motor with permanently lubricated sealed ball bearings and thermal overload protection.
- Energy Recovery Core:** The energy recovery core is manufactured from a blend of visil and nylon designed to transfer both sensible and latent heat. The core also acts as the MERV 8-12 filter.
- Controls:** Standard control is on/off function with capability of setting continuous flow within the operating flow range of 200-2000 CFM. Boost input, external control input, pressure input are available.
- Serviceability:** The unit is designed in two main housings (wheel housing and fan housing). The unit can be split in two for transport, service, and installation. Each of the two housings have two doors for ease of service. The wheel is accessible for cleaning without removal-or easily removed for more detailed cleaning.
- Mounting:** Unit comes with a vibration mounting stand. Any other orientation is acceptable with the proper designed mount and access.



Warranty The RecoupAerator is warranted to be free from defects in material and workmanship, and all parts for a period of 2 years from purchase date. The energy recovery core is warranted for 5 years with a proper yearly cleaning schedule.

Specifications

ULTIMATEAIR MODEL: 2000 DX		
	<i>US Units</i>	<i>Metric Units</i>
FLOW	200 – 2000 CFM	340 – 3740 CMH
ASE	92% - 95%	
TRE	44% - 53%	
CORE	Patented rotary random matrix polymer	
FILTRATION	MERV 8 - 12	EU 6 - 7
ELECTRICAL	208-240VAC, 25 Amp, 50/60 Hz, Single phase	
DIMENSIONS	64 H x 64 W x 42 D (inch); 700 lbs.	1.63 H x 1.63 H x 1.07 D
DUCT	4 Round Collars @ 18 Dia (inch)	4 Round Collars @ 458 Dia
MAINTENANCE	Yearly filter service – light maintenance	

Performance Data: RecoupAerator 2000DX

STATION	<i>1 outside</i>	<i>2 inside</i>	<i>3 inside</i>	<i>4 outside</i>
Temperature [C]	34.7	26.0	24.0	32.6
Relative Humidity	50.3	62.5	49.5	43.9
SRE: 70%	TRE: 53%	LPC: 0.43	ASE: 85%	
Temperature [C]	0.0	20.3	22.0	4.8
Relative Humidity	75.3	37.8	39.4	76.5
SRE: 83%	TRE: 79%	LPC: 0.69	ASE: 96%	

SRE: Sensible recovery effectiveness
TRE: Total recovery effectiveness
LPC: Latent performance coefficient
ASE: Apparent sensible effectiveness

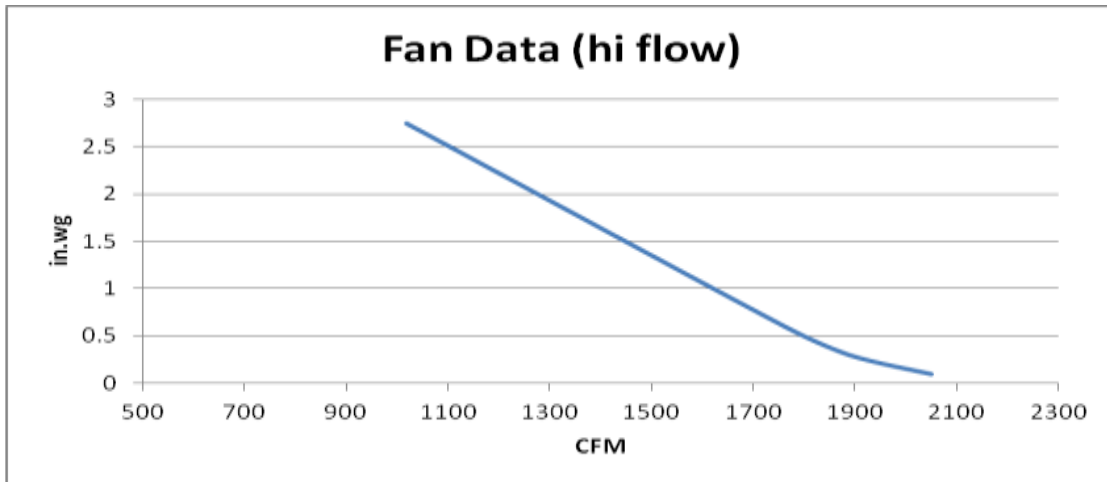

Flow Range Example

	PWM	Power	Flow	Watt/CFM
	<i>command</i>	<i>watt</i>	<i>cfm</i>	
Low	18%	129.5	240	0.54
Med	42%	462	720	0.64
Med - Hi	65%	1295	1210	1.07
High	100%	2730	1795	1.52

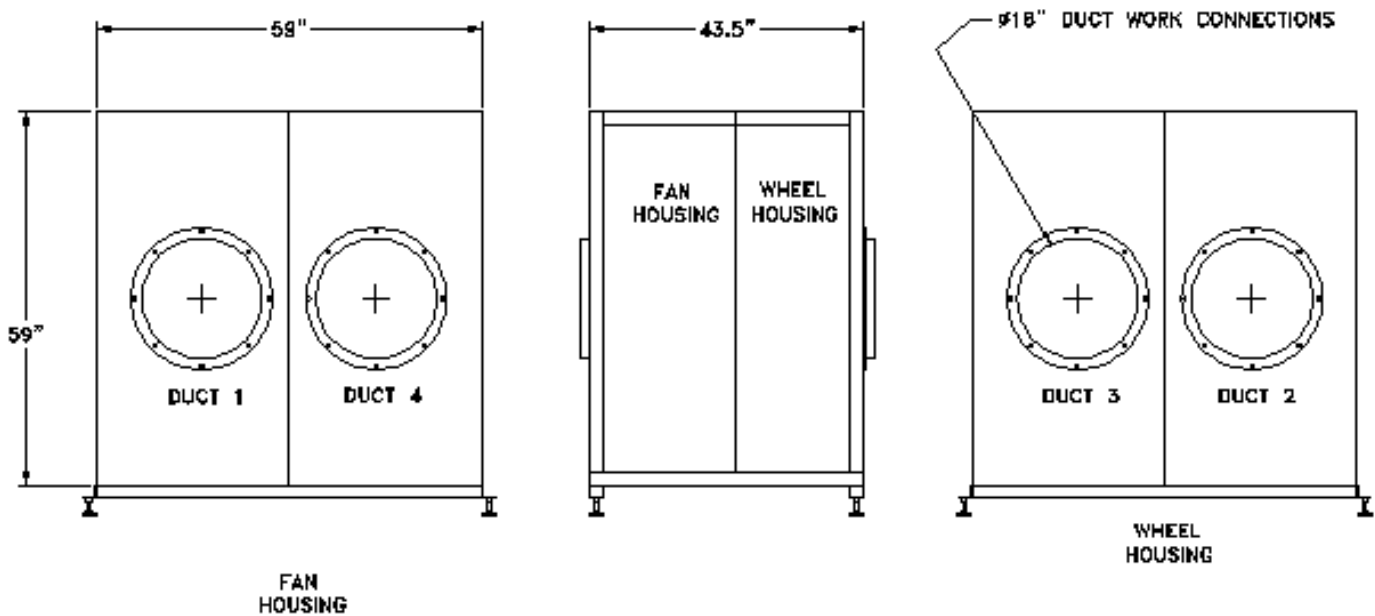

SETUP

DUCTING TO THE UNIT AT CONNECTIONS 2 AND 3 ON THE WHEEL HOUSING MUST HAVE AN EASILY REMOVABLE SECTION AT LEAST 30" LONG FOR MAINTENANCE ACCESS TO THE UNIT

DUCT LAYOUT:

DUCT 1	FRESH AIR FROM EXTERIOR
DUCT 2	FRESH AIR TO CONDITIONED SPACE
DUCT 3	EXHAUST AIR FROM CONDITIONED SPACE
DUCT 4	EXHAUST AIR TO EXTERIOR

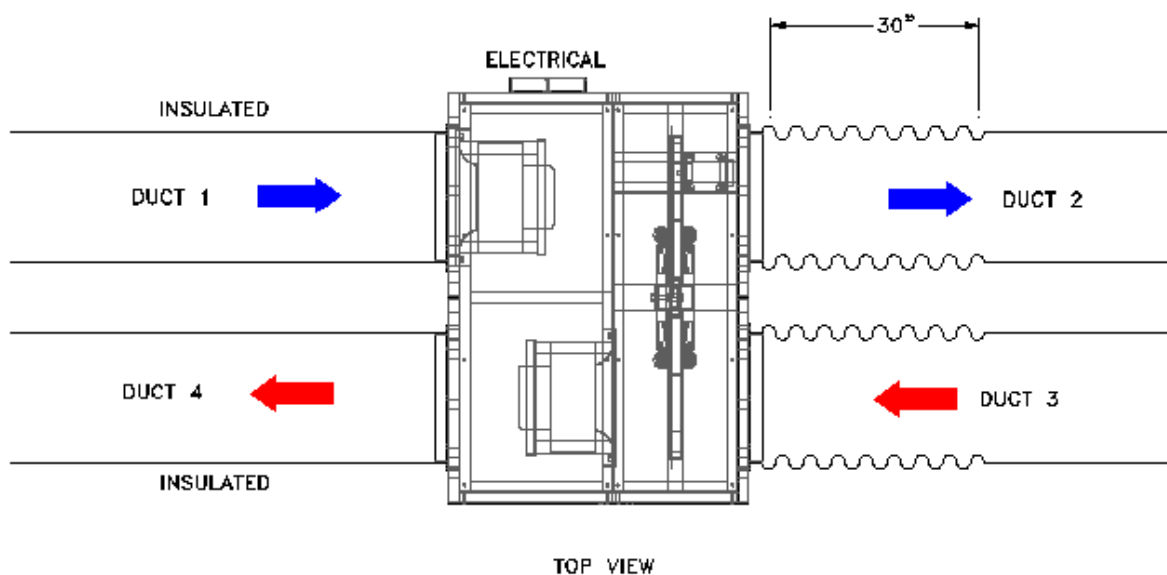

Install the 2000DX in a position where ventilation ducts can be easily run to each of the four duct connection points and there is adequate room to access each door on the unit for maintenance purposes. (See Airflow Diagrams for duct connection locations and airflow designations, these are also labeled on the unit.) It is recommended that there be at least 36" of clearance at each duct connection point to ensure there is enough room to remove the doors. To facilitate easy duct removal for maintenance, make a portion of each duct section, 24" to 36", easily removable.

Wiring Main Power

The 2000DX is supplied ready to be hard wired to a building power system. Terminal blocks are supplies in the electronics cover of the Fan Housing to connect power to. To connect the power wiring, remove the four sheet metal screws holding on the electronics cover. Be careful when removing the cover on the Fan Housing, as the control knob is in some configurations affixed to the cover. Wire the terminal blocks as shown in the illustrations. Please see the Diagrams for additional reference. Always wait at least 60 seconds before turning power back on.



Fan Housing Wiring Arrangement

The Fan Housing should be wired to a 240 VAC, single phase, 50 / 60 Hz dedicated circuit with a maximum service rating of 15 Amps.

Setup Duct Pressure Control System:

The DX2000 is set to provide a constant pressure inside the main duct despite the flow changes. The main control board DCC7545 and a feedback pressure transducer: Veris PXDLX01S are used to accomplish the function. Both the DCC7545 and the transducer are powered by the 24VAC power.

The transducer is mounted on the duct monitoring the inside pressure. The output signal is a DC signal varying from 0V~10V. The DCC7545 takes the signal as a feedback and uses the PID control strategy to maintain a constant pressure inside the duct which can be set by three jumpers on the DCC7545.

Flow transducer Model: **PXDLX01S** Manufacturer: **VERIS INDUSTRIES**

Jumper Settings:

- JP8 Set to FAST
- JP7 Set to IN W.C
- Jp5 Set to UNI
- JP4 Set to 10V
- OUTPUT Set to Volt

Rotary Switch Position:

The position of the flow transducers rotary switch corresponds with the RecoupAerator Main Control Board JP5.

Example: Transducer Rotary Switch in Position 2 requires the RecoupAerator JP5=0

Transducer Rotary Switch in Position 3 requires the RecoupAeraotor JP5=1

- **Position 0** - 0.1 inch w.c.
- **Position 1** - 0.25 inch w.c.
- **Position 2** - 0.5 inch w.c.
- **Position 3** - 1.0 inch w.c.

Setup Duct Pressure Control System: (cont)

RecoupAerator Main Control Board DCC 7545

(modified 200DX main control for Commercial 2000DX)

The DCC7545 is programmed to maintain constant duct pressure

Set the Pressure Control Point

- JP5=0 Range 0.5IN W.C.
 - JMP2=0 JMP3=0 *0.08 IN W.C.*
 - JMP2=0 JMP3=1 *0.125 IN W.C.*
 - JMP2=1 JMP3=0 *0.25 IN W.C.*
 - JMP2=1 JMP3=1 *0.5 IN W.C.*
- JP5=1 Range 1.0 IN W.C.
 - JMP2=0 JMP3=0 *0.1 IN W.C.*
 - JMP2=0 JMP3=1 *0.3 IN W.C.*
 - JMP2=1 JMP3=0 *0.5 IN W.C.*
 - JMP2=1 JMP3=1 *0.7 IN W.C.*

Manual Override is allowed in some scenarios.

To enable override, JP4= 1

When the override is not enabled, VR and BLWR must connected together via jumper wire.

- JP4=1 JP3=REM Wall Controller Override
- JP4=1 JP3=0~10V 0~10V input Override
- JP4=0 No Override

Wiring Duct Pressure Control Fan Housing

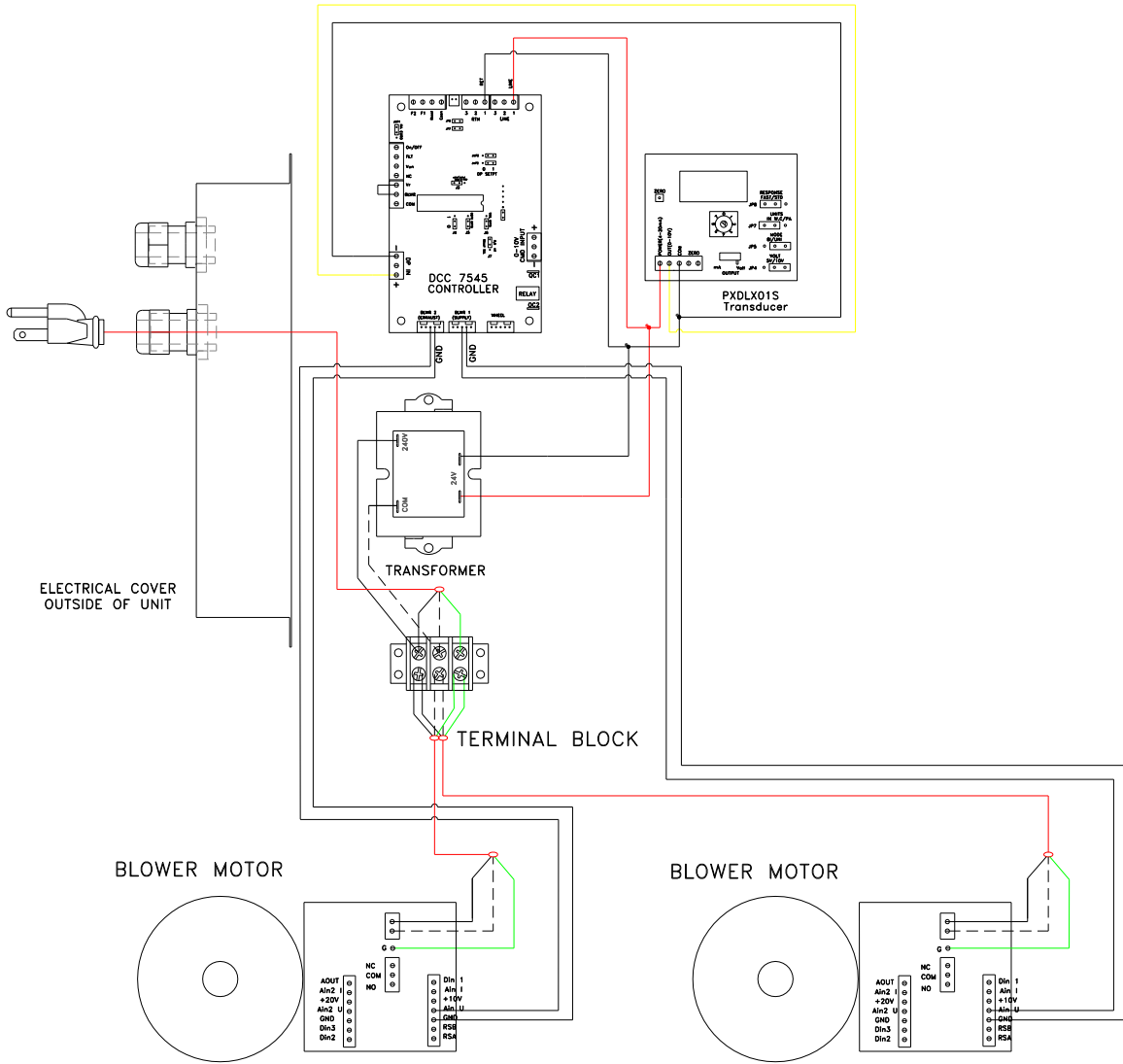

Optional Directly Wired CO2 control *(Main control requires CO2 program)*

When the RecoupAerator is wired directly to the optional CO2 monitor, the air flow will be controlled by the CO2 level input. The CO2 monitor will respond approximately as follows:

<800 ppm CO2:	lo flow	240 CFM
800-1000 ppm CO2:	med flow	720 CFM
1000-1200 ppm CO2:	med hi flow	1210 CFM
>1200 ppm CO2:	hi flow	1795 CFM

The control will default to the higher flow position – being the command from the CO2 monitor or via the dial control.

EconoCool Control (economizer)

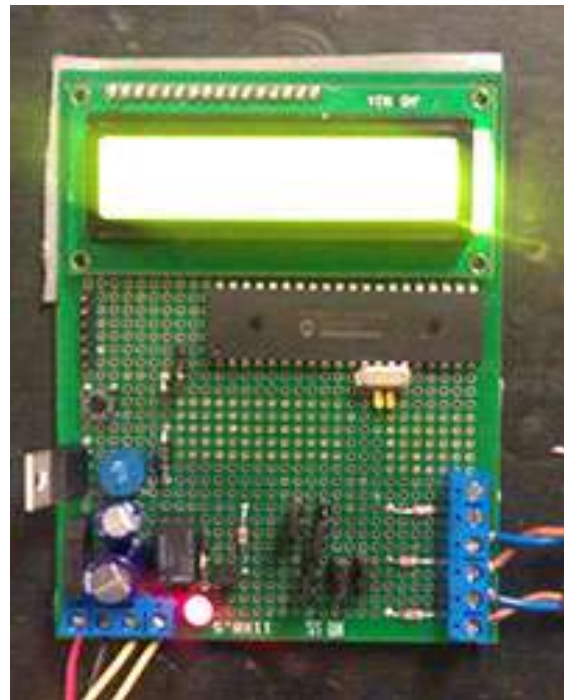
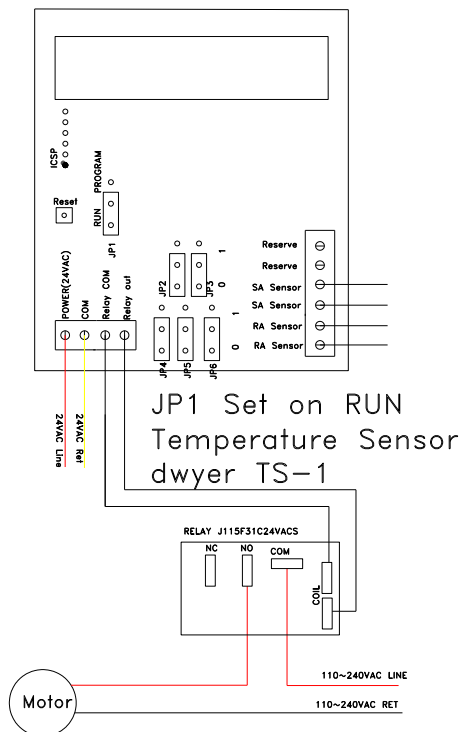

The RecoupAerator is EconoCool-equipped, so that you can make use of outside air in summer (e.g., during the night) to cool your building, thereby providing AC energy savings. Using a temperature sensor on the incoming air stream and a sensor on the room temperature, the RecoupAerator automatically stops energy recovery at some preset certain conditions. The user can select between the presets by changing JP2~JP6.



178 Mill Street
Athens, Ohio 45701
740.594.2277
ultimateair.com
info@ultimateair.com

For more information and/or ordering replacement parts, please contact UltimateAir Inc.