

**Evaporator for oil sample**

***ADP-513***

**Operation manual**

Please read this manual thoroughly in advance for the best performance of the instrument.

Ver.08

A/N 98-595-0292



## Table of contents

Page

1. Introduction .....	1
1-1. Outline.....	1
1-2. Cautions on this manual .....	2
1-3.  Safety symbols.....	3
2. Before you use the instrument .....	6
2-1. Supplied parts.....	6
2-2. Instillation and connecting power cable .....	9
2-2-1. Operating voltage check .....	9
2-2-2. Installation of desiccant tube .....	10
2-2-3. Assembly of evaporation bottle and filling base oil.....	11
2-2-4. Installation of K-thermocouple and its wiring .....	12
2-2-5. Installation of heater switch.....	13
2-2-6. Installation of waste bottle.....	13
2-2-7. Connection of carrier gas.....	14
2-3. Parts name and functions.....	15
3. Basic flow of operation.....	18
3-1. Sequence of measurement.....	18
3-2. Preparation for Karl-Fischer moisture titration .....	19
3-2-1. Setting measurement parameters .....	19
3-2-2. Preparation of titration cell .....	22
3-3. Temperature setup for Evaporation bottle .....	23
3-4. How to change parameters for temperature control .....	24
3-4-1. How to do Auto-tuning for PID constants .....	24
3-4-2. How to check PID constants.....	24
3-5. Method for moisture measurement.....	25
3-6. Procedure after measurement.....	26
4. Maintenance .....	27
4-1. Daily check .....	27
4-1-1. Replacement of silica gel /zeolite .....	27
4-1-2. Change the base oil.....	28
4-2. Other maintenance tips.....	30
4-2-1. Cleaning the warming tube.....	30
4-2-2. Cleaning the evaporation bottle .....	30
4-2-3. Replacement of K-thermocouple and its protection tube.....	31
4-2-4. Replacement of fuse .....	31
5. Troubleshooting.....	32
5-1. Temperature of evaporation bottle does not rise or is unable to control.....	32
5-2. Carrier gas does not flow .....	33
5-3. Carrier gas contains too much moisture.....	34
5-4. Repeatability of moisture measurement is poor .....	35
5-5. Drift level is high or unstable.....	36

6. Others .....	37
6-1. Parts list .....	37
6-2. Flow chart .....	40
6-3. Technical data.....	41
6-4. Warranty and after-sale service .....	42

# 1. Introduction

## 1-1. Outline

We appreciate your patronage over KEM products by purchasing the ADP-513 Evaporator for oil sample. This instrument when connected with KEM's Karl Fischer moisture titrator, evaporates water in lubricants or petroleum products for its micro measurement without side reaction contained in the sample.

### [Features]

- 1) The evaporator provides moisture titration by indirect method without the necessity of solvent, and enables consecutive measurement without discarding wastes after each run.
- 2) The transparent evaporation bottle offers visible progress in the sample within the bottle.
- 3) Precise and stable control of temperature is assured by PID thermal control.
- 4) The specification conforms to D6384 Standard Test Method for Determination of water in Petroleum Products, Lubricating Oils, and Additives by Coulometric Karl Fischer Titration.
- 5) The evaporation bottle is easily cleaned so that even samples which may easily contaminate surrounding parts can be handled smoothly.
- 6) The base oil can be drained out easily by the specially designed drain-out system.
- 7) Safety measures to avoid overheating are provided by the digitally controlled temperature setting secured by thermal semi-conductor devices.

## 1-2. Cautions on this manual

Operate the apparatus with this Manual kept by your side at all times.

You will find some descriptions marked as shown below. They are intended to call your careful attention.

1. Possible danger such as human body injury or death:

 <b>Warning!</b> <b>Accidents such as injury to human body or death are possible unless those the warning is strictly observed.</b>
---

2. Possible danger such as loss of property:

 <b>Caution!</b> <b>Property may be damaged unless the caution is strictly observed.</b>
--

3. Failure of performance



<b>Note!</b> <b>Product may not perform in full conformance to the specification unless the note is observed.</b>
--



- It is prohibited to copy or make use of a part or all of this Manual.
- If you should find any part in this manual not clear to understand or missing article, contact your local dealer or sales representative.
- We will not be held responsible for any failure or damage or loss arising from measurement results by the instrument.
- This Manual is based on the apparatus of standard specification. For details of those of special specification, see its manual.



### 1-3. Safety symbols



#### Always observe these signs and instructions.

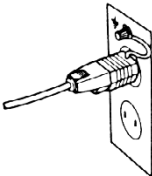

You must observe cautionary messages and warnings in order to protect yourself as well as prevent others from physical injury or property damages.

 <b>Warning</b> This symbol means "Danger of severe injury or possible death".
 <b>Caution</b> This symbol means "Danger of injury or property damage".

 This symbol means prohibition of an act.
 This symbol means mandatory.

 <b>WARNING!</b>	
You must ground earth wire of power cable.	
	Ground the green wire of adapter if power tap is 2-pin outlet.  3-pin plug has earth line to ground by itself when plugged in.
	
Danger of electric shock if not grounded to earth.	

 <b>WARNING!</b>	
Use the same type and rating of fuse. Be sure to plug out power cord before replace the fuse.	
	
Danger of fire if a wrong fuse is loaded.	

 <b>WARNING!</b>	
Do not use volatile chemical or work in flammable gas.	
	
Danger of explosion inside the instrument.	



## WARNING!

Wear safety glasses, gloves or protective mask if necessary, and well ventilate the room.



Danger of injury on your skin or in the eyes by splashing chemical. Also your windpipe may get hurt if toxic gas is breathed in.



## CAUTION!

Unplug the power cord when the unit can be troubled or exposed to a lightning.



Failure to observe this caution may result in a damage to the instrument.



## CAUTION!

Do not operate in a way other than specified in the manual.



Danger of fire, electric shock or damage to the instrument.



## CAUTION!

Do not open housing case or overhaul the unit for repair except by an authorized service person.



Danger of fire, shock or malfunctioning of the unit.



### Installation location

Avoid the following environmental influences.

- Powerful vibration
- Direct sunlight
- Corrosive gas
- Power source of large load fluctuation or where powerful electric or magnetic field
- Operating temperature beyond the specified range (5~35°C)
- Ambient humidity above 85%RH

### Power source

- Power source that can be used is AC100-120V±10% or AC220-240V±10% of 50Hz/60Hz.
- Connect directly to power source outlet.
- Do not use power source from a receptacle already connected to many other devices.

### Storage

- If the instrument is not going to be used for a long period of time, pack the whole unit into the carton box which contained the instrument when first delivered.
- For storage, avoid a place of high or too low temperature and humidity, and dusty area.

### Carrier gas

- This evaporator heats up to maximum 200°C. To avoid deterioration of the base oil, it is recommended to use nitrogen gas (inactive gas) for carrier gas to transfer moisture.  
Adjust the gas supply pressure under 50kPa (approximately 0.5kgf/cm<sup>2</sup>).

### Base oil





- The heated base oil when added to the sample helps its evaporation. For base oil, use vacuum pump oil or high temperature lubricating oil of high purity and endurance. Such oil is available from KEM products distributors.

## 2. Before you use the instrument



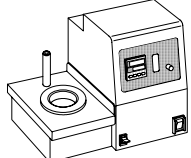

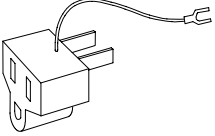

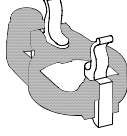
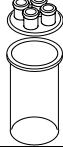
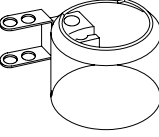
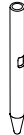
### 2-1. Supplied parts







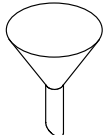
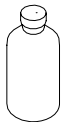
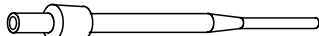
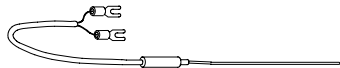
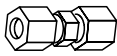
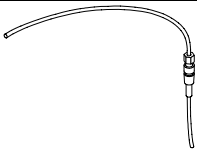
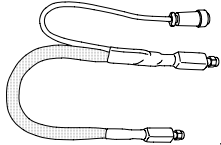

The delivered carton box contains ADP-513 Main unit, accessories and operation manual. Please check the delivered parts with the checklist below. If you should find any missing or broken part or parts, contact your local dealer or sales representative.

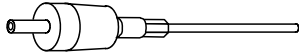
-ADP-513 Supplied parts-

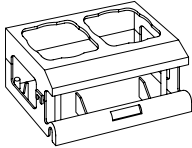
Part name	Part code	Qty	Sketch
Main unit	ADP-513	1 set	
Power code for AC 100-120V for AC 220-240V for AC 220-240V (UK) for AC 220V (China)	98-320-3198 98-320-3461 98-320-4199 64-000-1800-48	1 pce	
Adapter for power connector *1 (for AC 100V/ 110V)	98-320-3199	1 pce	
Ground wire *1 (for AC 100V/ 110V)	98-433-3331	1 pce	
Desiccant tube	98-433-0094	2 pcs	
Bottle holder	98-433-0073	1 set	
Evaporation bottle	98-710-0046	1 set	
Protective cover	98-710-0043	1 pce	
Nozzle pocket	98-430-0051	2 pcs	

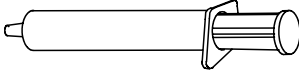
\*1 These accessories are not supplied except for Japan and Taiwan.

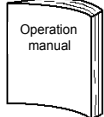
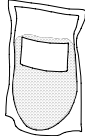
Part name	Part code	Qty	Sketch
Side stopper for syringe	98-433-3223	1 pce	
Port plug 15/20	98-720-3115	1 pce	
Septum	98-523-3161	10 pcs	
KF grease	98-433-3138	1 pce	
Funnel	98-500-3159	1 pce	
Base oil (250mL)	98-591-0004	1 pce	
Thermocouple protection tube	98-710-0041	1 pce	
K-thermocouple	98-337-3220	1 pce	
Joint	98-581-0059	1 pce	
Tube for carrier gas	98-433-0076	1 pce	
Warming tube (Heater tube)	98-433-0015	1 pce	
Grand joint $\phi 6$	98-581-0062	1 pce	

Part name	Part code	Qty	Sketch
Bubbler tube	98-433-0075	1 pce	
Waste bottle	98-433-0083	1 pce	
Drain tube	98-433-0077	1 pce	
Bottle holder	98-560-0017	1 pce	
Nozzle	98-550-6429	1 pce	
Exhaust tube	98-710-3051	1 pce	
Syringe 20mL	98-320-3225	1 pce	
Silicone rubber	98-523-3227	5 pcs	
Fuse (T4A/250V)	98-338-9502	2 pcs	
Operation manual	98-595-0292	1 copy	
Silica gel (500g)	98-820-3269	1 pce	
Zeolite (5A 500g)	98-810-3412	1 pce	

## 2-2. Installation and connecting power cable

### 2-2-1. Operating voltage check

- 1) Make sure that the power switch is in the "OFF" position.

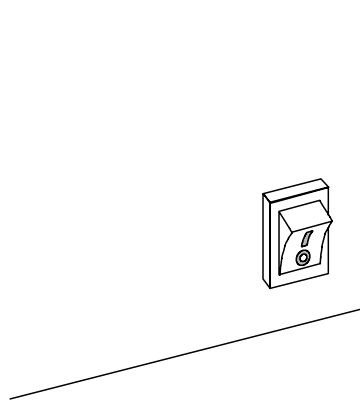

- 2) Connect the supplied power cable to the unit.

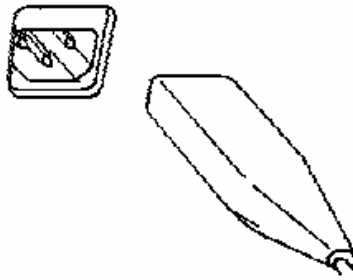

- 3) Put in the power code to an electric outlet.

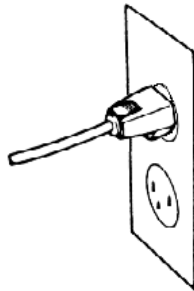

<3-pin outlet>

3-pin plug automatically grounds the earth line.

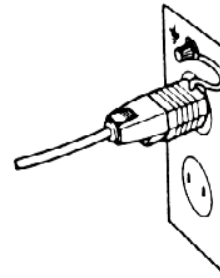

<2-pin outlet>

Be sure to ground the earth wire of AC-3P adapter.

### **Warning!**

**You must ground earth wire of power cable.  
Danger of electric shock if not grounded to earth.**

## 2-2-2. Installation of desiccant tube

- 1) Fill the desiccant tube with Silica gel (Zeolite). Note here that you should not allow Silica gel (Zeolite) to enter the indicated portion by plugging the part with a finger. After filling the tube with Silica gel (Zeolite), lay the sponge and cover the lid. The lid should be screwed in for secured attachment.
- 2) Install the desiccant tube onto the main unit.

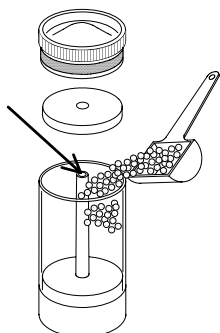

<Supply of silica gel/zeolite>

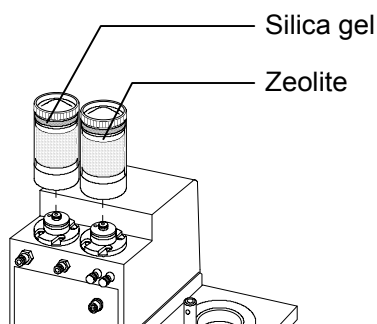

<Installation of desiccant tubes>

### **Warning!**

Fill the desiccant tube with silica gel/zeolite, giving a few mm gap on its top. If it is filled up, carrier gas may not flow smoothly.

### **Note!**

Use fresh silica gel and Zeolite. Any used desiccants will not absorb moisture, leading to unreliable measurement results. For replacement of silica gel and Zeolite, refer to 4. Maintenance.

### 2-2-3. Assembly of evaporation bottle and filling base oil

- 1) Turn down the evaporation bottle lever inward to assemble the bottle.
- 2) Install the nozzle pocket onto the protective cover. Fasten the screw to fix the cover on Main unit.
- 3) Install the assembled bottle onto Main unit. Fasten the bottle by the knob.
- 4) Install the side stopper onto the bottle. When an optional sampler for oil is going to be used, install a ball stopper instead of side stopper for syringe.
- 5) Attach a funnel on the bottle and deliver approximately 50mL base oil into the bottle (up to the lower mark).

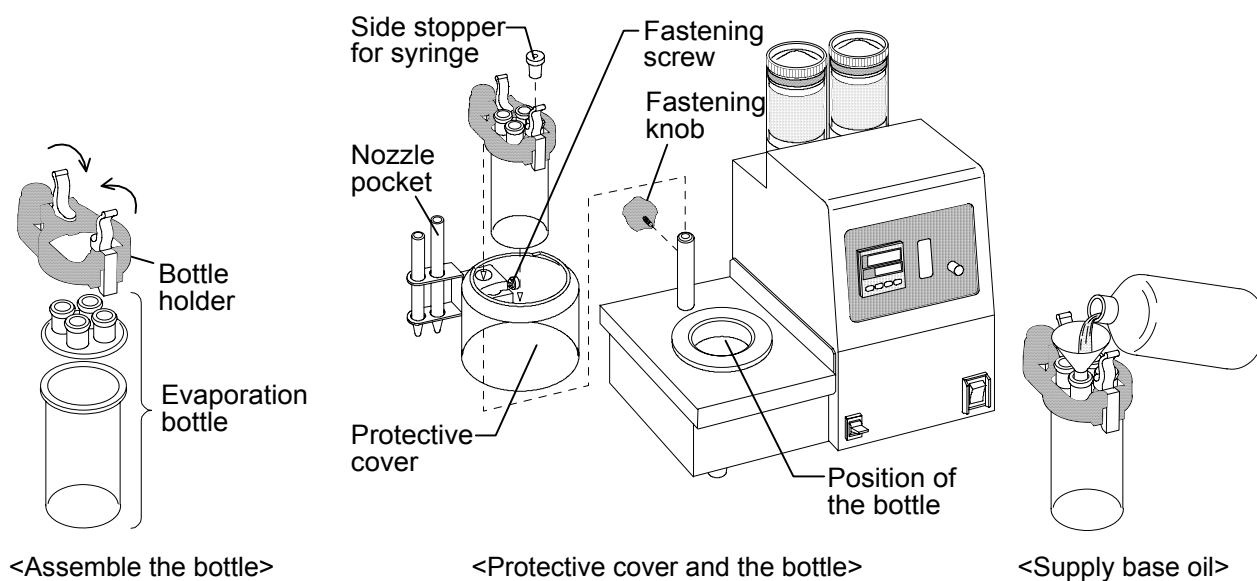

#### **Warning!**

Apply KF grease around the sliding area of glass. Without grease or with grease of wrong type the assembly may be broken in the worst case hurting the operator.

## 2-2-4. Installation of K-thermocouple and its wiring

- 1) Assemble K-thermocouple and its protection tube.
- 2) Connect the lead of K-thermocouple to the thermocouple terminal on the rear panel of Main unit.
- 3) Install the thermo couple protection tube onto the evaporation bottle.

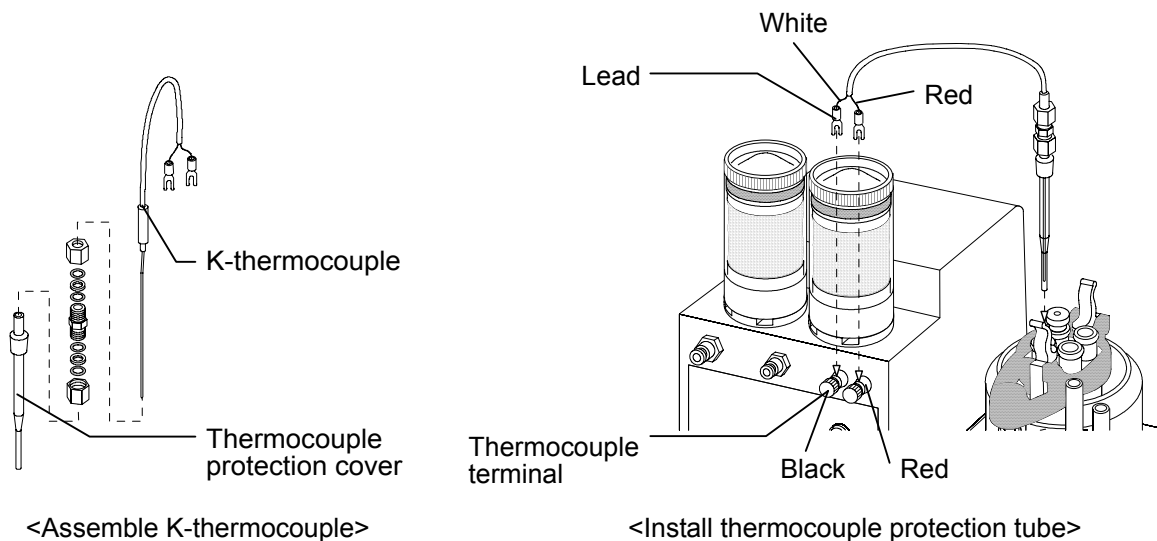

### **⚠ Caution!**

The thermocouple leads indicate pole (+,-). Match the poles on the terminal.

Thermocouple lead		Thermocouple terminal
+	→	+
-	→	-

### **⚠ Warning!**

If the K-thermocouple is set to the evaporation bottle in a wrong way, it will cause uncontrollable temperature rise of the bottle, resulting in physical injury of the operator.

- 4) Install the tubing for carrier gas onto the bottle. Connect the supplied tubing to Carrier Gas Out on the back of Main unit.

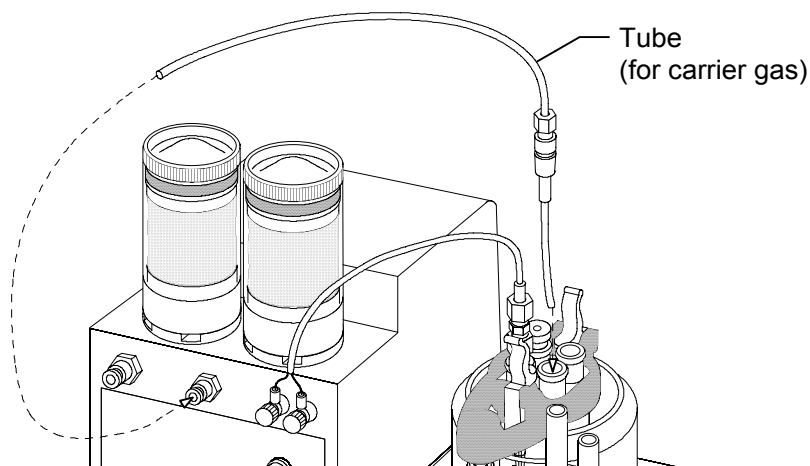

<Connect the tube for carrier gas>



### 2-2-5. Installation of heater switch

- 1) Connect the bubbler tube and ground joint  $\phi 6$  to the warming tube. (Ground joint  $\phi 6$  to the electrode connector)
- 2) Connect the power connector of warming tube to the warming tube connector on the back of Main unit.
- 3) House the bubbler tube in the nozzle pocket of protective cover.
- 4) Install the warming tube onto the evaporation bottle, referring to the below illustration of bottle position.

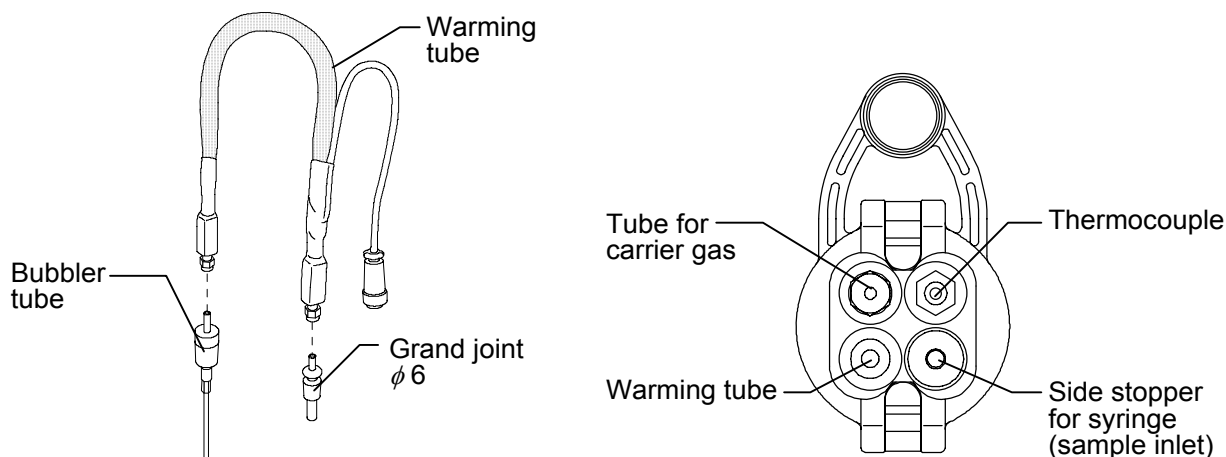

<Installation of Bubbler tube and Ground joint  $\phi 6$ >

<Installation position onto Evaporation bottle>

#### **Note!**

**When connect a heater tube to a bubbler, tighten them with fingers.  
Never use any tools such as a plier or a wrench which might become them deformed.**

### 2-2-6. Installation of waste bottle

- 1) Install the drain tube onto waste bottle.
- 2) Place the waste bottle in the reagent bottle holder.
- 3) House the end of drain tube in the nozzle pocket of protective cover.

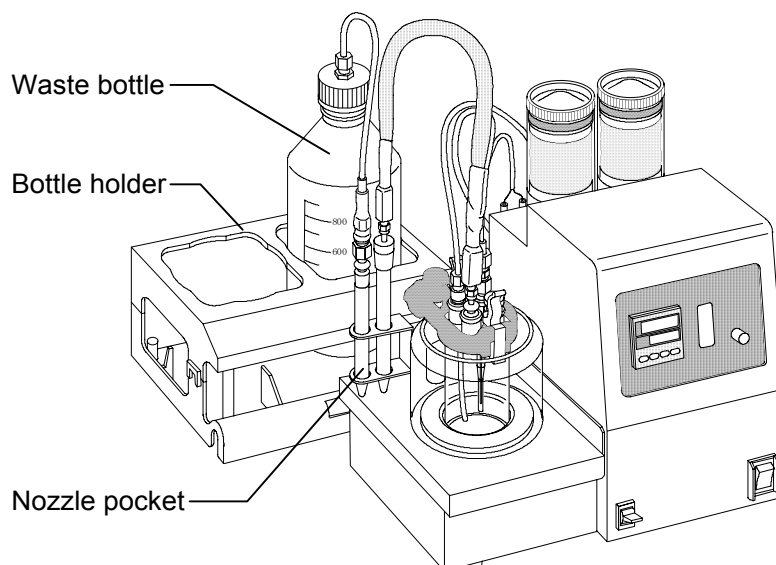

## 2-2-7. Connection of carrier gas

### **Note!**

User needs to prepare a nitrogen gas (purity 99.99%) in container, a governor (pressure adjustable to  $50\text{kPa} \doteq 0.5\text{kgf/cm}^2$ ) and the necessary tube line.

The tube line for carrier gas must be made of non-hygroscopic materials like copper, stainless or tetrafluoroethylene.

- 1) Connect the carrier gas tube (I.D.  $\phi 6$  mm) to the tapered end of nozzle.
- 2) Insert the tube joint into Carrier Gas In on the back of Main. Fix the carrier as line with wires to avoid derailing.

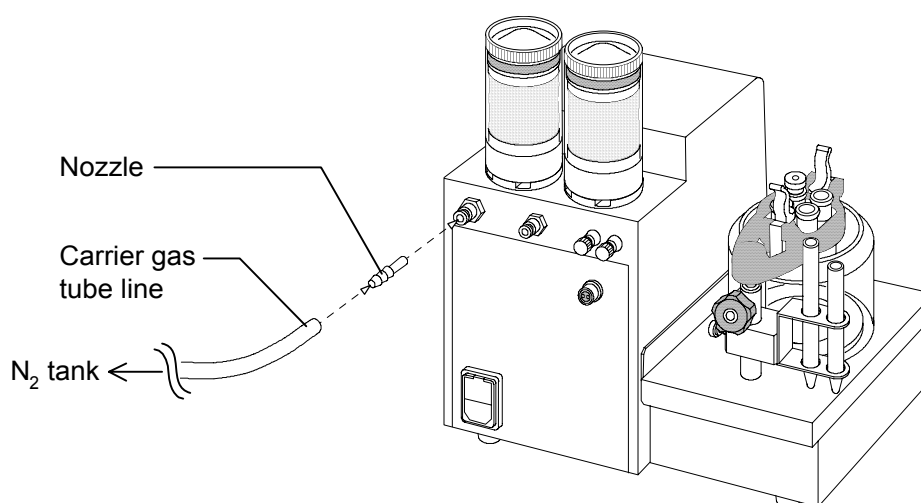

### **⚠ Caution!**

Supply carrier gas under  $50\text{kPa} \doteq 0.5\text{kgf/cm}^2$  adjusted by governor. Gas supply under excessive pressure will cause not only broken tube line or cock but may hurt the operator by unlocking the stopper or joint.

### **Note!**

The tube joint for Carrier Gas In can connect O.D.  $\phi 6\text{mm}$  tube directly. Therefore, it is not necessary to provide a nozzle for tube O.D.  $\phi 6\text{mm}$  if available.

## 2-3. Parts name and functions

<Front view>

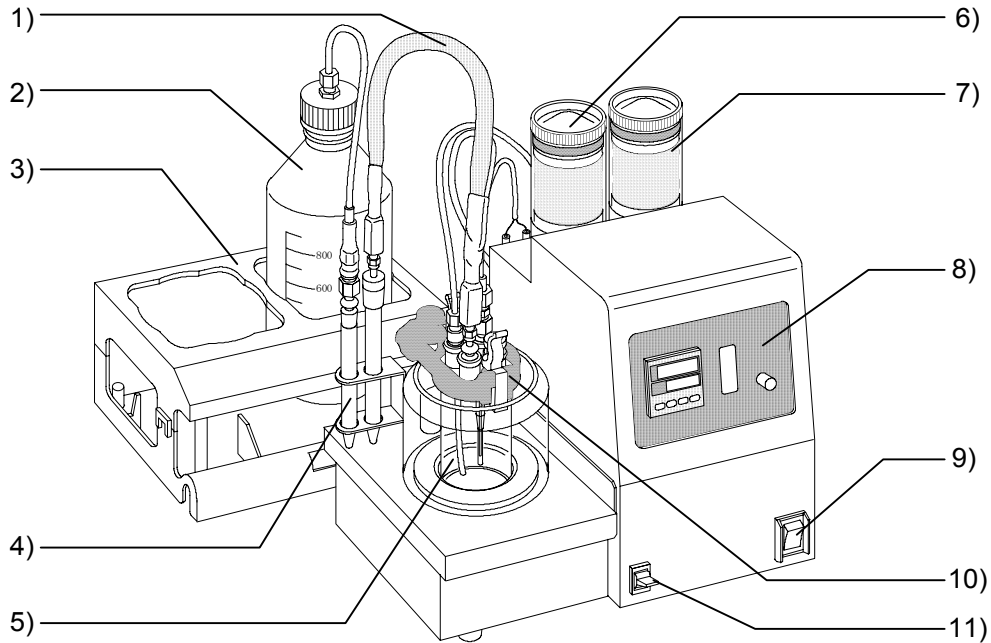

- 1) Warming tube (Heater tube)  
This tube leads the moisture from the evaporated bottle over to the titration cell. Its tip is attached with a bubbler.
- 2) Waste bottle  
This bottle stores the base oil
- 3) Reagent bottle holder  
The waste bottle is housed in here.
- 4) Nozzle pocket  
It houses the bubbler tube and drain tube after measurement is over.
- 5) Evaporation bottle  
Moisture in a sample is evaporated here with base oil heated up.
- 6) Zeolite desiccant tube  
Moisture in carrier gas is absorbed after silica gel. Use 5A graded Zeolite.
- 7) Silica gel desiccant tube  
It absorbs moisture in the carrier gas. When hygroscopic capacity turns down, its color turns to reddish.
- 8) Control panel  
This panel provides various meters including the flow rate gauge, digital controller, etc.
- 9) Power switch  
Turns on or off the power of Main unit.
- 10) Sample inlet  
Sample material is injected into the evaporation bottle by a syringe. Side stopper for syringe or ball stopper is provided when first assemble.
- 11) Heater/Drain switch (Heater On/Heater Off/Drain)  
This switch turns on or off of heater/drain power.  
The drain position is controlled with the momentary switch.

<Rear view>

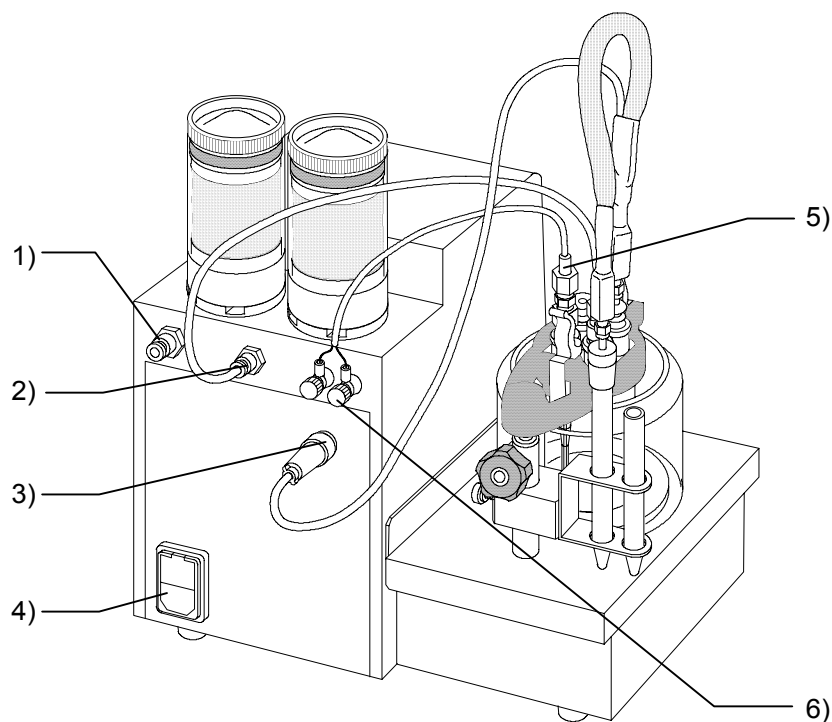

1) Carrier gas inlet (Carrier Gas In)

The connecting tube for this inlet is made of stainless tube or  $\phi 6 \times \phi 4$ mm fluorine tube. The pressure for carrier gas has to be adjusted below 50kPa (approximately 0.5kgf/cm<sup>2</sup>).

2) Connector for carrier gas (Carrier Gas Out)

This is the outlet for carrier gas after passing through the desiccants. Connect the supplied tube for carrier gas to introduce the gas into the evaporation bottle.

3) Connector for warming tube (heater tube)

Power for warming tube is connected.

4) Power plug

The power cable is connected.

5) K-thermocouple

This is the sensor to measure temperature inside the evaporation bottle. The sensor is made of K-thermocouple.

6) Thermocouple terminal

This is the terminal to connect the K-thermocouple.

<Control panel>

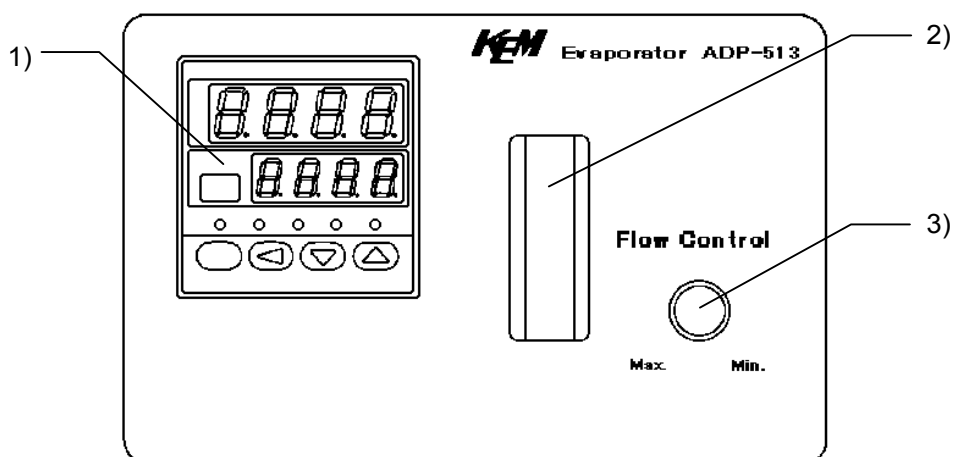

1) Digital control indicator

This controls the temperature for the evaporation bottle. It is controlled by PID system. After power is turned on, the below message appears for about 6 seconds.

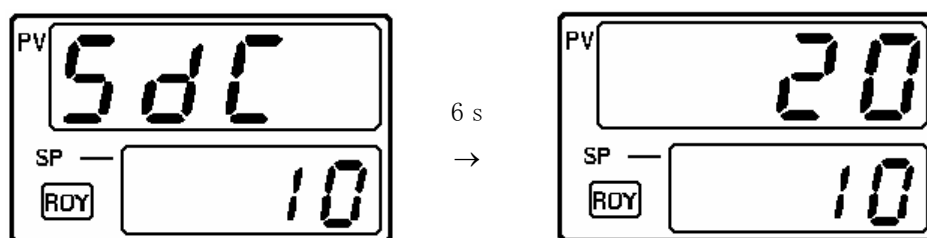

2) Flow rate indicator

It shows the flow rate of carrier gas. The typical flow rate for carrier gas is 200mL/min (at the middle line position).

3) Flow control knob

This knob controls the carrier gas flow rate. When it turns clockwise, the flow rate goes down, and when counterclockwise, it goes up.

### 3. Basic flow of operation

#### 3-1. Sequence of measurement

The measurement progress goes according to the below flow chart. For details of each step, refer to the following pages:

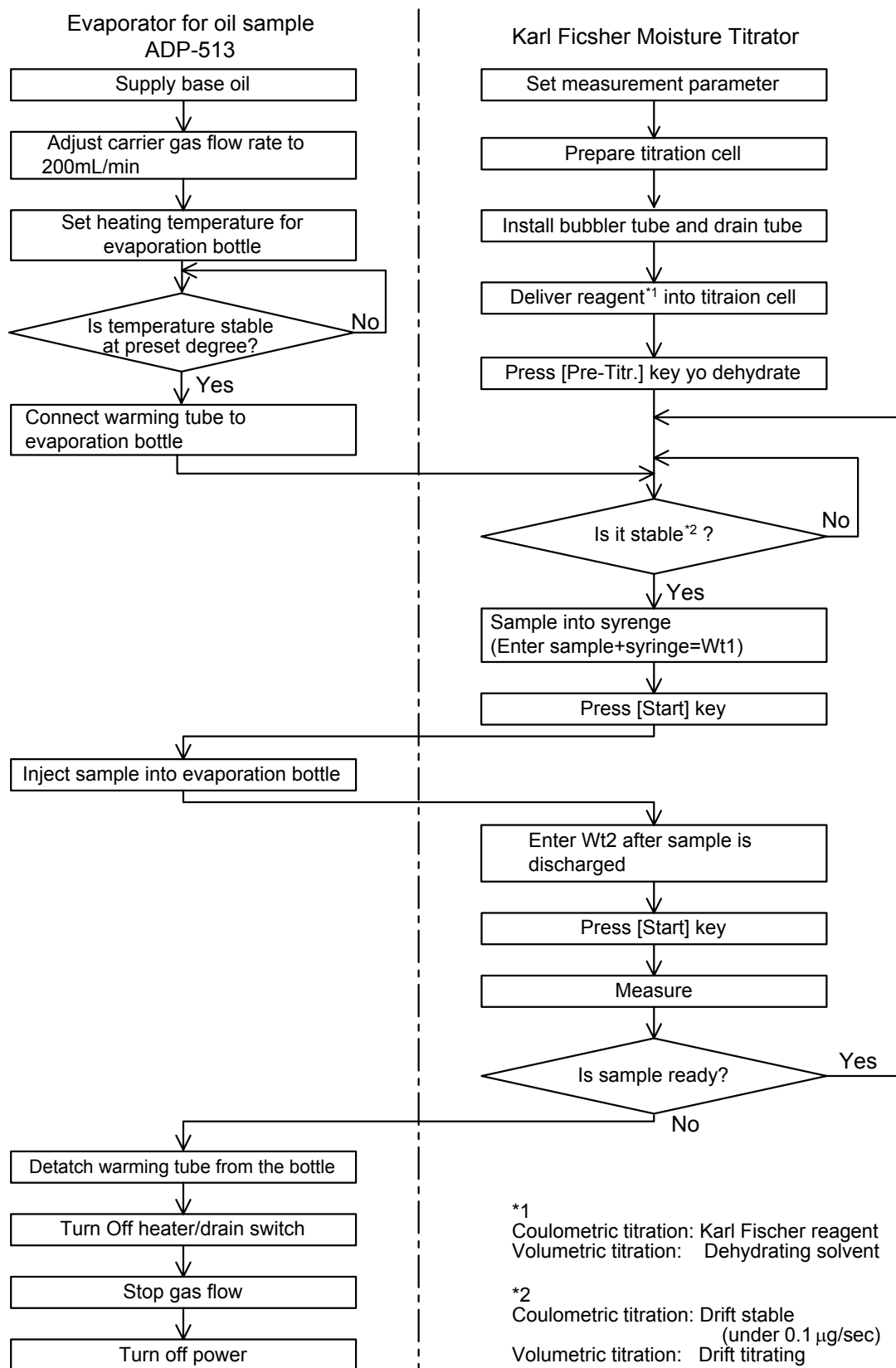

## 3-2. Preparation for Karl-Fischer moisture titration

### 3-2-1. Setting measurement parameters

It is necessary to set up measurement parameters (Press [Function] - [Method edit] button, [Titration] key or [TITR. PARA] key) and sample settings (Press [Sample] button) for use of this instrument in conjunction with a Karl Fischer moisture titrator. The typical parameters are shown in the below chart:

<Volumetric KF moisture titration>

Key	Model	MKA-610-TT	MKA-610-ST
	Parameter		
Method			
Titration parameter	Titration mode	Normal	Normal
	Titr. burette No.	1	1
	t(stir)	0s	0s
	t(wait)	15s	15s
	t(max) *1	1800s	1800s
	t(interval)	0s	0s
	Max. volume	10mL	10mL
	Dose mode	Off	Off
Control parameter	End time	0s	0s
	Final volume	0.01mL	0.01mL
	Titration speed	3	3
	Detector mode	1	1
	Drift titr.	On	On
	Start mode	Manual	Manual
	End level	75mV	75mV
Sample settings	Option	Off	Off

Key	Model	MKA-520 MKA-510N	MKS-520 MKS-510N	MKS-500	MKA-510	MKS-510
	Parameter					
Method		4	4	Indirect	4	4
Titration	Titr. Mode	Normal	Normal		1	1
	Titr. Buret No.	1			1	
	End Time	0s	0s	0s	0s	0s
	Final Volume	0.01mL	0.01mL	0.01mL	0.01mL	0.01mL
	Titr. Speed	3	3	3	Slow	Slow
	Detector Mode	1	1	Normal	1	1
	t(stir)	0s	0s	0s	0s	0s
	t(wait)	15s	15s		15s	15s
	t(max) *1	1800s	1800s	1800s	1800s	1800s
	t(interval)	0s	0s		0s	0s
	Drift Titration	On	On	On	On	On
	Start	Manual	Manual		Manual	Manual
	Max. Volume	10mL	10mL	10mL	10mL	10mL
	Dose mode	Off			Off	
	Oven	Off	Off		Off	Off

Key	Model		MKA-210	MKS-210
	Parameter			
Method			4	4
TITR.PARA	Titr. Mode		1	1
	Titr. Buret No.		1	
	End Time		0s	0s
	Final Vol.		0.01mL	0.01mL
	Titr. Speed		slow	slow
	Detector Mode		1	1
	D. Time		0s	0s
	L. Time *1		1800s	1800s
	I. Time		0s	0s
	Blank		on	on
	Start		manu	manu
	Max. Volume		10mL	10mL
	Dose mode		off	
	Oven		off	off

\*1) t(max) and Limit time are related to the evaporating time. The evaporating time has to be changed according to the water content of each sample.

<Coulometric KF moisture titration>

Key	Model		MKC-610-DT	MKC-610-NT
	Parameter			
Method				
Titration parameter	Titration mode		H2O	H2O
	t(stir)		0s	0s
	t(wait)		15s	15s
	t(max) *1		1800s	1800s
	Drift stop		Off	Off
Control parameter	Cell type		2-Comp.	1-Comp.
	Stable		0.1ug/min	0.1ug/min
	Control gain		5.0	5.0
	Start mode		Manual	Manual
	End level		200mV	200mV
Sample settings	Option		Off	Off



Key	Model		MKC-520	MKC-501	MKC-510
	Parameter		MKC-510N	MKC-500	
Method			4		4
Titration	t(stir)		0s	0s	0s
	t(wait)		15s	15s	15s
	t(max) * <sup>1</sup>		1800s	1800s	1800s
	Drift Stop		Off	Off	Off
	Control Gain		5.0		5.0
	Stable		0.1ug/min		0.1ug/min
	Start		Manual		Manual
	Oven		Off		Off

Key	Model		MKC-210
	Parameter		
Method			5
TITR.PARA	Delay; sec?		0s
	Limit; sec? * <sup>1</sup>		1800s
	Control Gain?		5.0
	End Level		off
	Stable; Δμg		0.1ug/min
	Blank		on
	Start		manu
	Oven		off

\*1) t(max) and Limit time are related to the evaporating time. The evaporating time has to be changed according to the water content of each sample.

**Note!**

**This instrument is used in conjunction with a Karl Fischer moisture titrator. For parameter settings, refer to the manual of your Karl Fischer moisture titrator.**

### 3-2-2. Preparation of titration cell

- 1) Remove the side stopper for syringe at sample inlet, and install the bubbler tube with warming tube connected from ADP-513.
- 2) Remove the desiccant tube and install the exhaust tube.
- 3) Deliver KF reagent in the titration cell for coulometric titration, and dehydrating solvent for volumetric titration.

For Volumetric KF titration

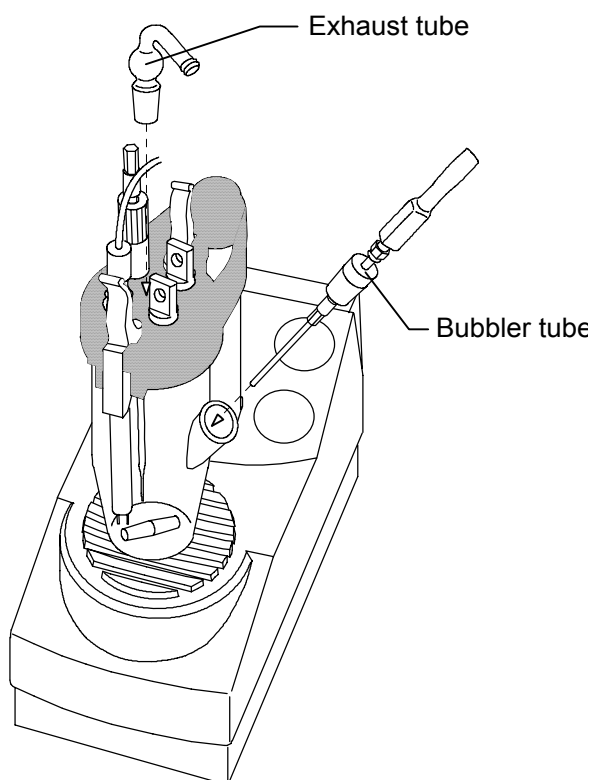

For Coulometric KF titration

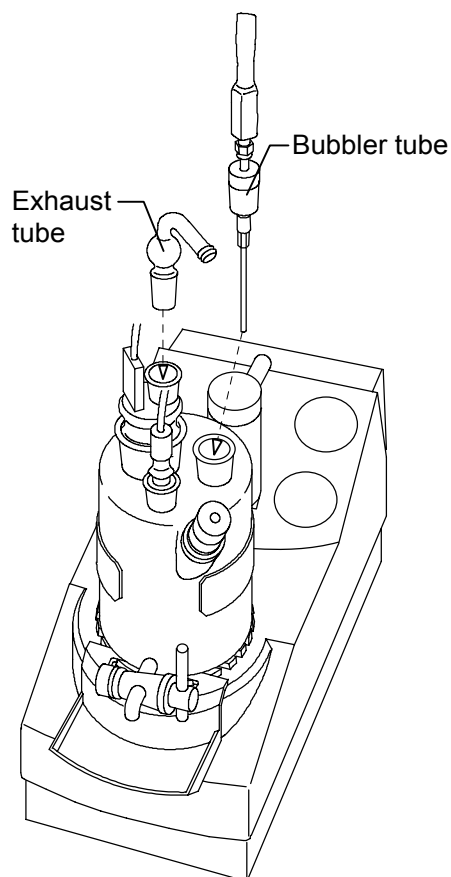

**Note!**

**For parameter setup and information on Karl Fischer reagent, refer to the manual of your KF moisture titrator.**

### 3-3. Temperature setup for Evaporation bottle

To change evaporation temperature, use the digital indicator on the control panel.

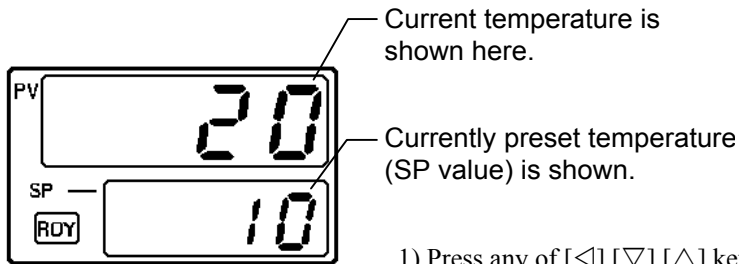

1) Press any of [ $\triangleleft$ ] [ $\nabla$ ] [ $\triangle$ ] key.

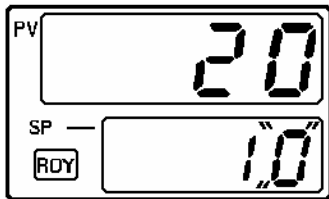

2) The last digit of current preset degree (SP value) blinks.

3) Select the last digit with [ $\nabla$ ][ $\triangle$ ] key.

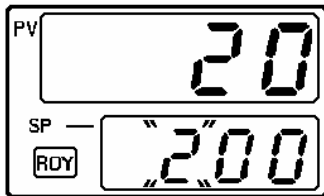

4) Change digit with [ $\triangleleft$ ] key.

Likewise as in step 3) above, change the value of blinking digit.

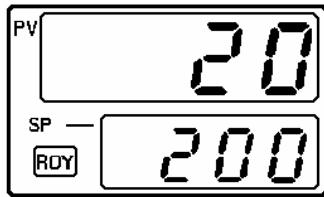

5) Press [PARA] key to finish the setup.

#### **Note!**

Unless entered within 2 seconds, the current value is input automatically.

#### **Note!**

For detailed information on the digital indicator, contact your local dealer or sales representative.

#### **Caution!**

Do not set more than 200°C for evaporating temperature. Excessive heat will melt the resin parts of the bottle holder, thus malfunction measuring system.

### 3-4. How to change parameters for temperature control

The parameters for temperature control on this unit are preset as such that the temperature control becomes optimum when a sample is placed in the unit at 150 °C of evaporation temperature. Should temperature control when placing a sample in the unit be unstable, adjust the PID constants in the following steps:

#### 3-4-1. How to do Auto-tuning for PID constants

Determine PID constants with the auto-tuning:

- 1) Set the evaporation temperature according to the section “3-3. Temperature setup for Evaporation bottle”.
- 2) Press [PARA] key for at least three seconds in the RUN mode and get in the parameter setup mode.
- 3) Select “Control = 1” or “2” with [▽] or [△] key.
- 4) Press [PARA] key and alter the items to show “At (Auto-tuning)”.
- 5) ‘At’ should be set at “At=1”. When it is already set at “1,” reset if as “1 → 0 → 1”.

#### **Note!**

**When canceling the auto-tuning during the setup, set at “At = 0”.**

#### **Note!**

**During auto-tuning, the LED in the lower right column keeps blinking. When auto-tuning ends, the LED will be put off.**



#### 3-4-2. How to check PID constants

Make certain of the set PID constants as follows:

- 1) Determine PID constants according to the section “3-4-1. How to do Auto-tuning for PID constants”.
- 2) Press [PARA] key for at least three seconds in the RUN mode and get in the parameter setup mode.
- 3) Press [PARA] key and alter the items to show “P”.
- 4) Check the value of “P”. The target value is 5 through 10. If the value is out of this range, change the value to the range (5 – 10) with [◀], [▽] or [△] key.
- 5) Press [PARA] key and alter the items, followed by checking the values of both “I” and “D”.

#### **Note!**

**The default values of PID constants are “P=10, I=318 and D=79”.**

### 3-5. Method for moisture measurement

**Note!**

**Make sure the carrier gas flows at the rate 200mL/min.  
Make sure the evaporation bottle is heated at preset temperature.**

- 1) Press [Pre-Titr.] key on KF moisture titrator to perform pretitration for the cell.
- 2) Wait until the display shows “Drift stable” or “Drift titrating” after pretitration.
- 3) Weigh the sample + syringe. Press [Sample] key to show Wt1(g) and enter the weight.
- 4) Press [Start] key. When the display shows “Sample in and Press [Start] key”, inject the sample into the evaporation bottle, and press [Start] key.
- 5) The display shows Entering weight (Wt2) screen after measuring. Weigh the syringe after sample discharge and enter its weight as Wt2.
- 6) The results will be calculated according to the preset formula, and printed out.

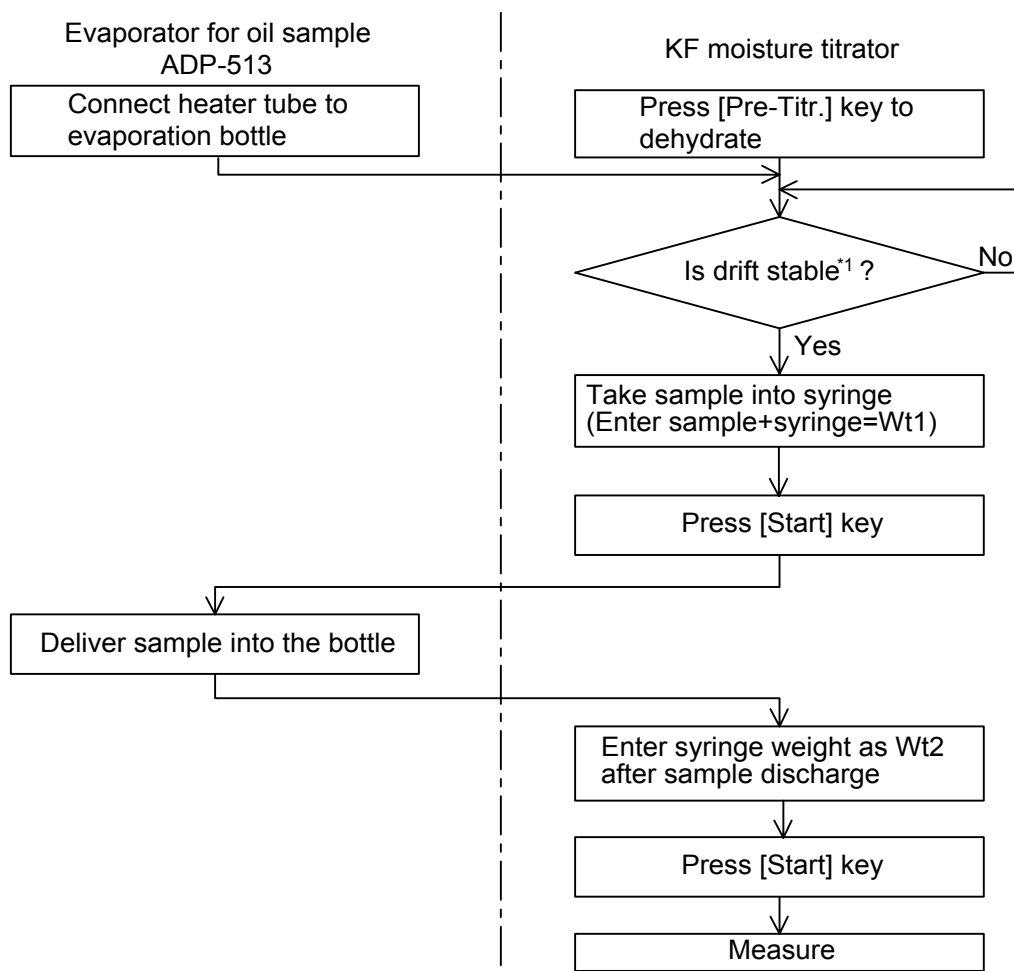

\*1  
Coulometric titration: Drift stable  
(under 0.1µg/sec)  
Volumetric titration: Drift titrating

### 3-6. Procedure after measurement

- 1) After the measurement is over, replace the bubbler attached to the titration cell of KF moisture titrator with a port plug. Replace the exhaust tube with desiccant tube.

For volumetric KF moisture titrator

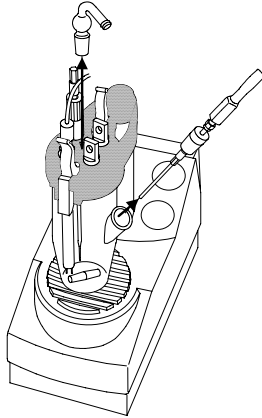

For coulometric KF moisture titrator

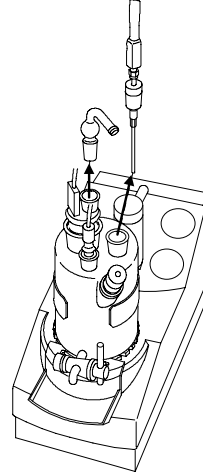

#### **⚠ Caution!**

**Do not stop carrier gas flow until the bubbler is removed.**

**If the bubbler is removed without flow of carrier gas, the KF reagent inside the bubbler may flow backward into the evaporation bottle.**

#### **⚠ Warning!**

**Right after the measurement is over, some parts including evaporation bottle and warming tube are still hot, and do not touch these areas.**

#### **⚠ Caution!**

**To remove the bubbler, remove first with KF moisture titrator.**

**If left without the bubbler removed, the KF reagent may flush back to the evaporation bottle, and the siphoned boiling reagent may hurt the operator.**

- 2) House the removed bubbler in the nozzle holder.

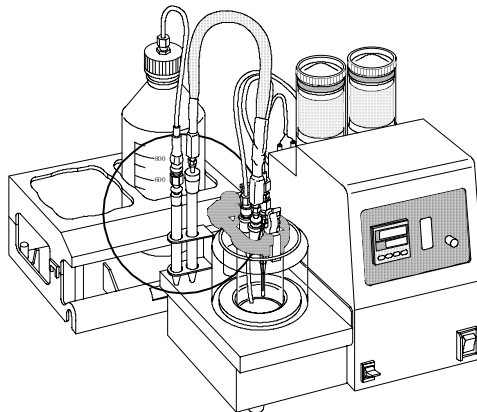

- 3) After making sure the evaporation bottle has been cooled down, turn off the flow of carrier gas and the power.

## 4. Maintenance

### 4-1. Daily check

#### 4-1-1. Replacement of silica gel /zeolite

When the silica gel changes to reddish color, its hygroscopic capacity goes down. Replace it with new one.

When zeolite's hygroscopic capacity goes down, the back ground level or drift of carrier gas goes up to 2 to 3 times. In this case, replace it with new one.

Put in silica gel/zeolite in the container while closing the indicated portion by a finger to avoid clogging.

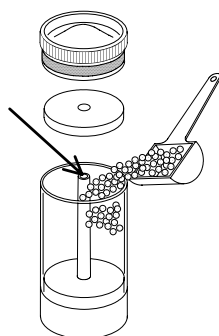

<Supply of silica gel/zeolite>

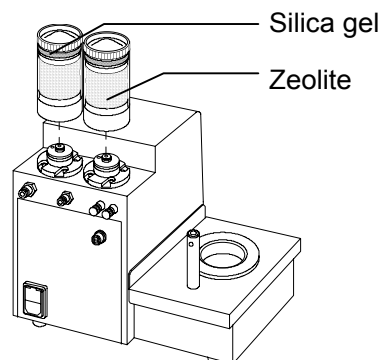

<Installation of desiccant tubes>

#### **Note!**

The background level or drift may be increased by the life of KF reagent, leak from tube line, etc. Check these factors as well as the life of Zeolite.

#### **Warning!**

Do not put in silica gel/zeolite full in the container. A little space is necessary between silica gel/zeolite and the top.  
Full silica gel/zeolite in the container may make flow rate of carrier gas unstable.

#### 4-1-2. Change the base oil

The total amount of base oil and sample are indicated by the upper limit mark on the evaporation bottle. Before it reaches the limit mark, change the base oil.

#### **Note!**

**Make sure the carrier gas is flowing.**

#### **Warning!**

**Drain out the base oil as it is still warm. Wear protective gloves and mask to avoid burn.**

#### **Caution!**

**When draining the base oil, lift the tip of the carrier-gas tube to the position higher than the fluid level of the base oil. Draining the base oil with the tip of the tube immersed into it may cause the backflow of the base oil to the unit.**

- 1) Remove the warming tube from the evaporation bottle.
- 2) Undo the nuts for the carrier-gas tube and raise the tip of the tube to the height by circa 1cm higher than the fluid level of the base oil.  
Then, screw down the nuts to secure the tube again.

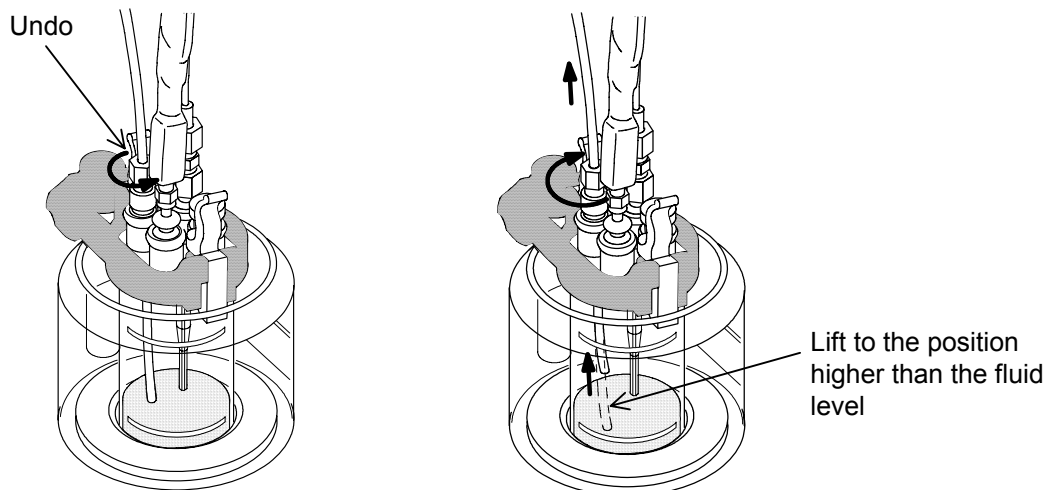



- 3) Install the drain tube onto the evaporation bottle.
- 4) Turn the heater/drain switch to Drain, and keep pressing the switch. Under Drain, the base oil inside the bottle will be drained out by carrier gas. When you remove your finger on the switch, the lever returns to Heater Off position, and stops draining.

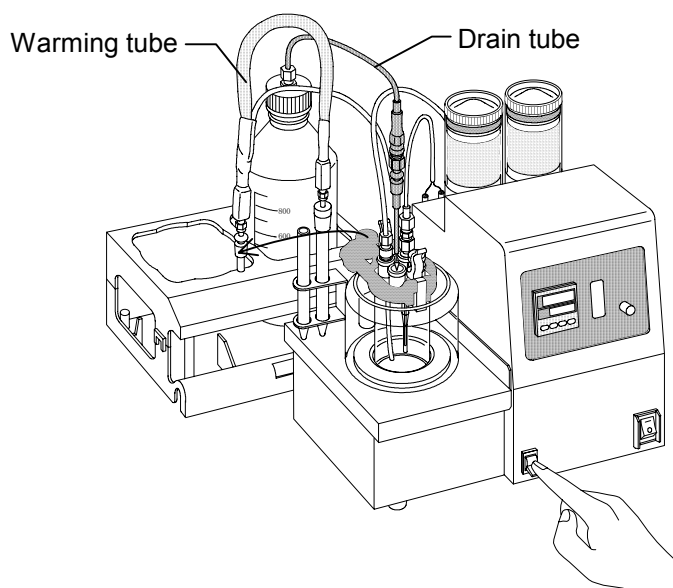

**Note!**

**The drained base oil must be disposed of as organic waste liquid.**

- 5) Turn off the power switch, set a funnel onto the evaporation bottle and pour the base oil into the bottle to the lower calibration mark.

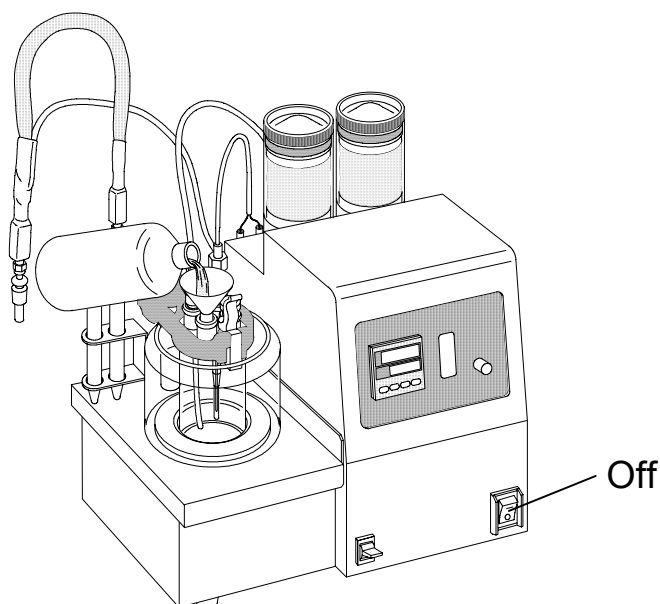

**Note!**

**Be sure to turn off the power switch when pouring the base oil into the evaporation bottle.**

- 6) Undo the nuts for the carrier-gas tube and restore the tip of the tube to the original height.

## 4-2. Other maintenance tips

### 4-2-1. Cleaning the warming tube

#### **Warning!**

**The power switch must be turned off whenever the warming tube connector is connected or disconnected. If the power switch is kept on, it may cause malfunctioning.**

- 1) Make sure the power switch is turned off.
- 2) Remove the warming tube from Main.
- 3) Deliver alcohol like ethyl alcohol from the one end of warming tube.
- 4) Repeat the step 3 for 3 to 4 times.
- 5) Flow dry air or nitrogen gas through the warming tube, and dry it.
- 6) Install the warming tube onto the Main.

### 4-2-2. Cleaning the evaporation bottle

#### **Warning!**

**To remove the evaporation bottle, make sure the temperature of heater is sufficiently lowered. Otherwise, you may be hurt by high heat.**

- 1) Drain the base oil.
- 2) Turn off the power of Main.
- 3) Remove K-thermocouple and tube lines from the evaporation bottle.
- 4) Remove the bottle from Main.

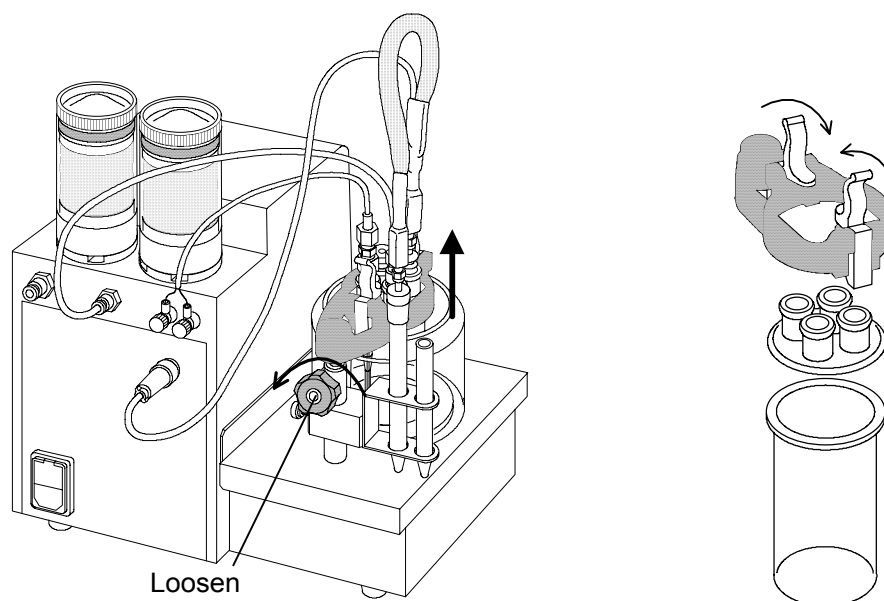

- 5) Clean the evaporation bottle with alcohol.
- 6) Reassemble the system.

### 4-2-3. Replacement of K-thermocouple and its protection tube

In case the thermocouple or its tube is broken, replace it as below:

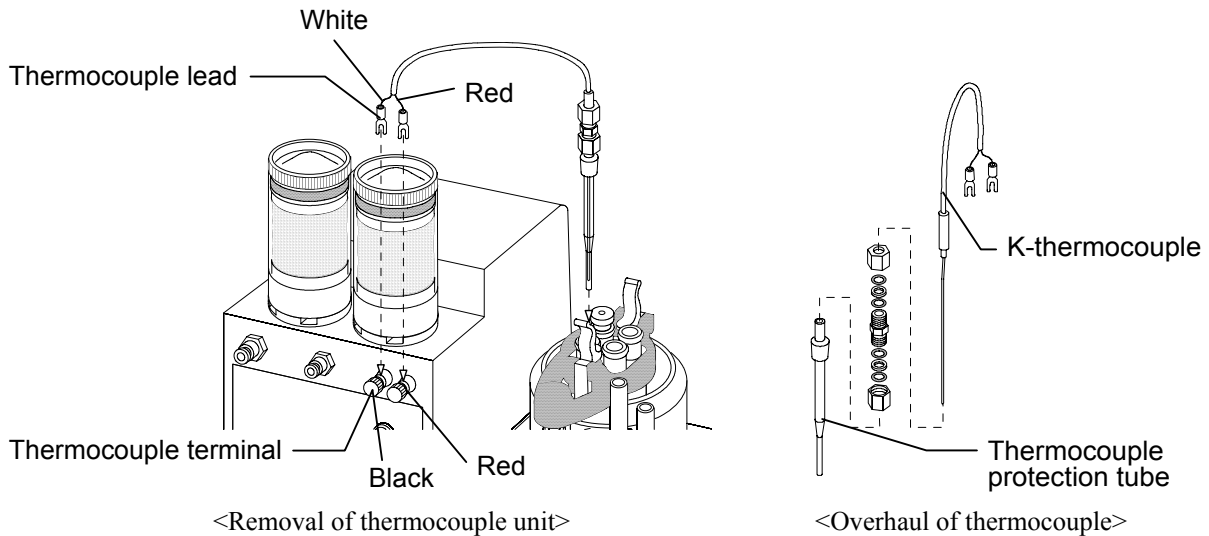

- 1) Remove the thermocouple from evaporation bottle.
- 2) Overhaul the thermocouple.
- 3) Replace the broken thermocouple or its tube with new one.
- 4) Install the thermocouple onto evaporation bottle

#### **Warning!**

**Before the thermocouple is removed, make sure the temperature of evaporation bottle is low enough. With high heat remaining on it, you may get hurt and burned.**

### 4-2-4. Replacement of fuse

- 1) Turn off the power switch and disconnect the power cord.
- 2) Open the lid above the receptacle with a regular screwdriver.
- 3) Pull out the two fuse holders with a regular screwdriver.
- 4) Replacing the blown fuse with new one, plug them in so that arrows on the fuse holders and the lid can point the same direction. Close the lid.

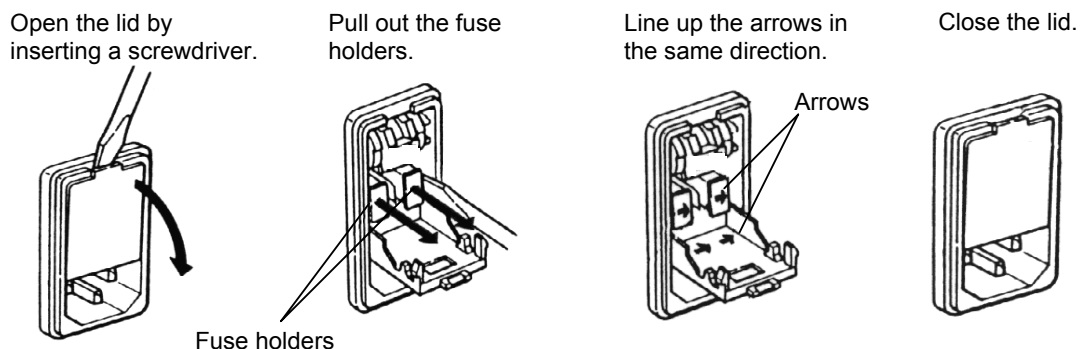

#### **Warning!**

**Danger of electric shock. Make sure to turn of the power switch and disconnect the power cord before you replace the fuses.**

## 5. Troubleshooting

### 5-1. Temperature of evaporation bottle does not rise or is unable to control

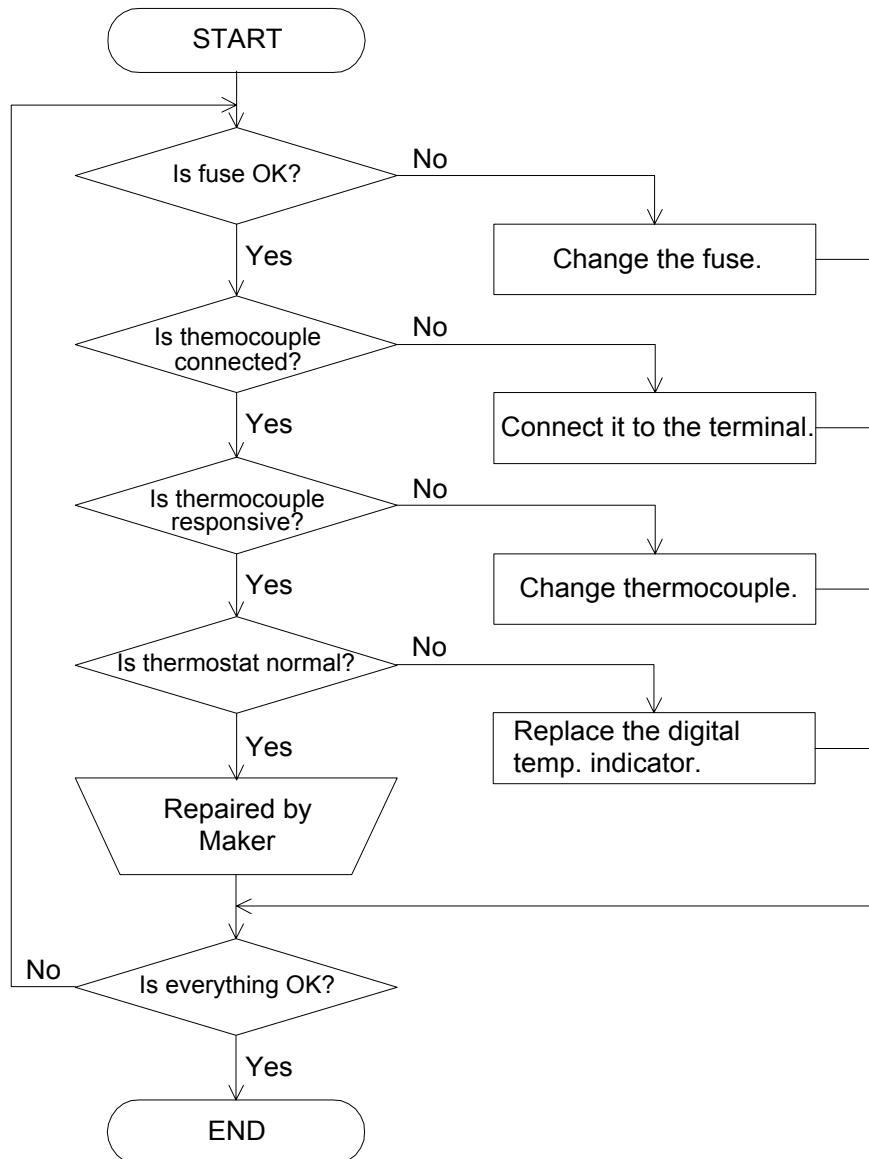

## 5-2. Carrier gas does not flow

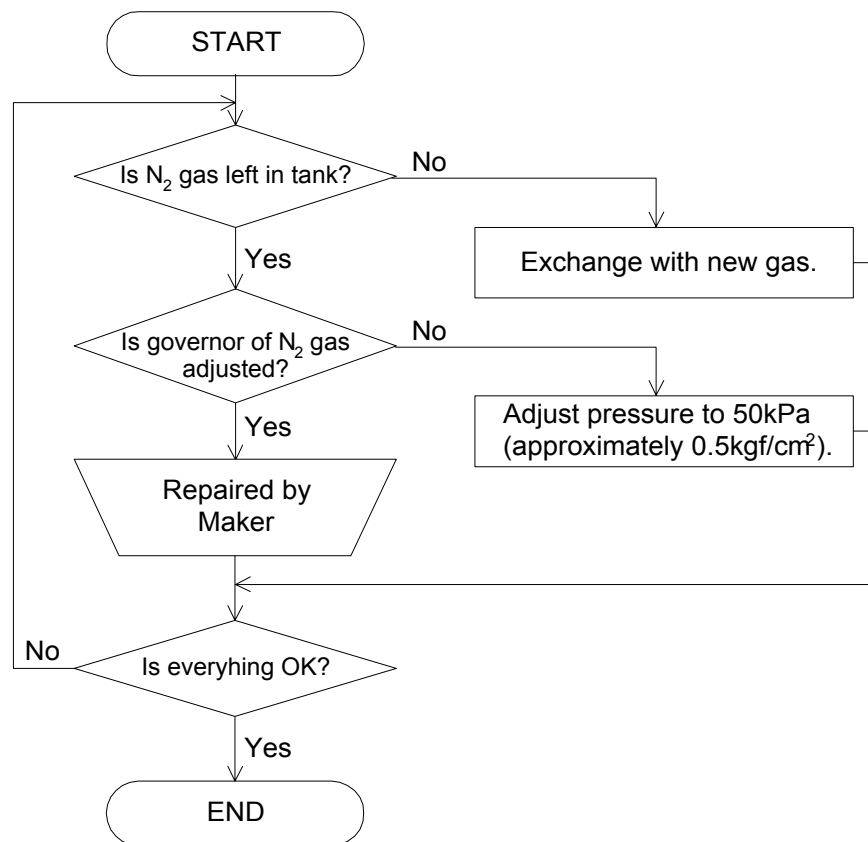

### 5-3. Carrier gas contains too much moisture

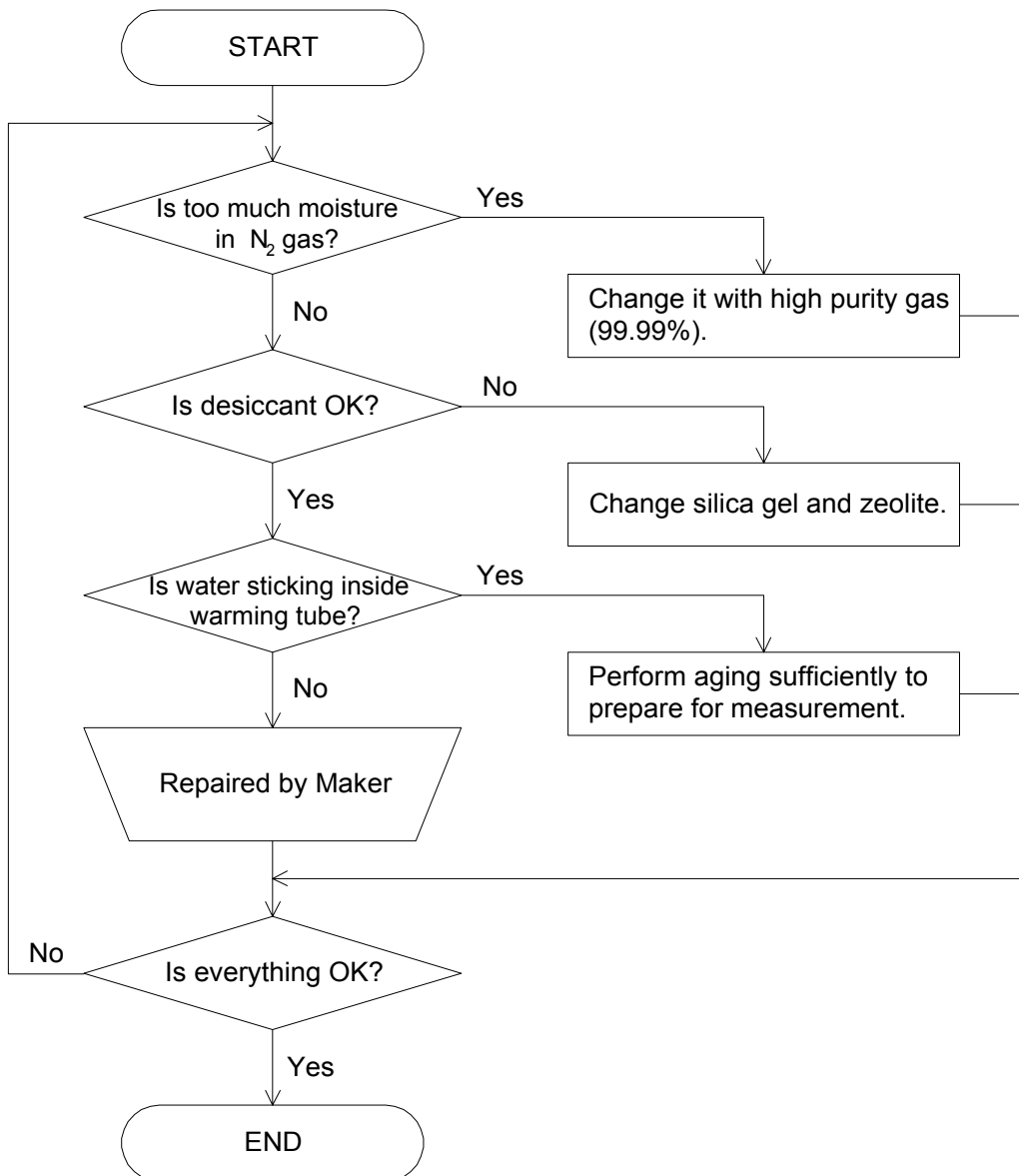

### 5-4. Repeatability of moisture measurement is poor

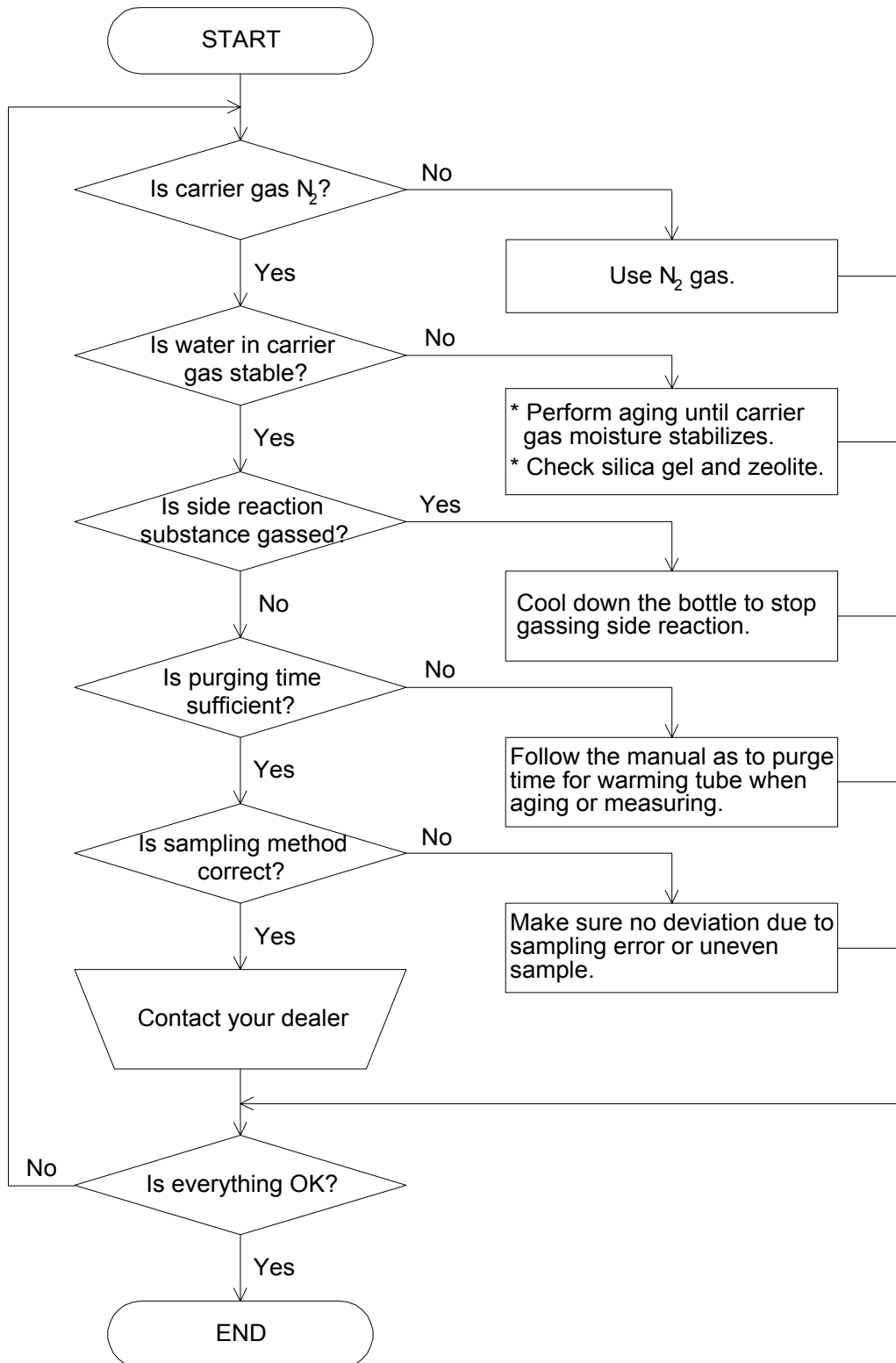

## 5-5. Drift level is high or unstable

(when a coulometric KF moisture titrator is used)

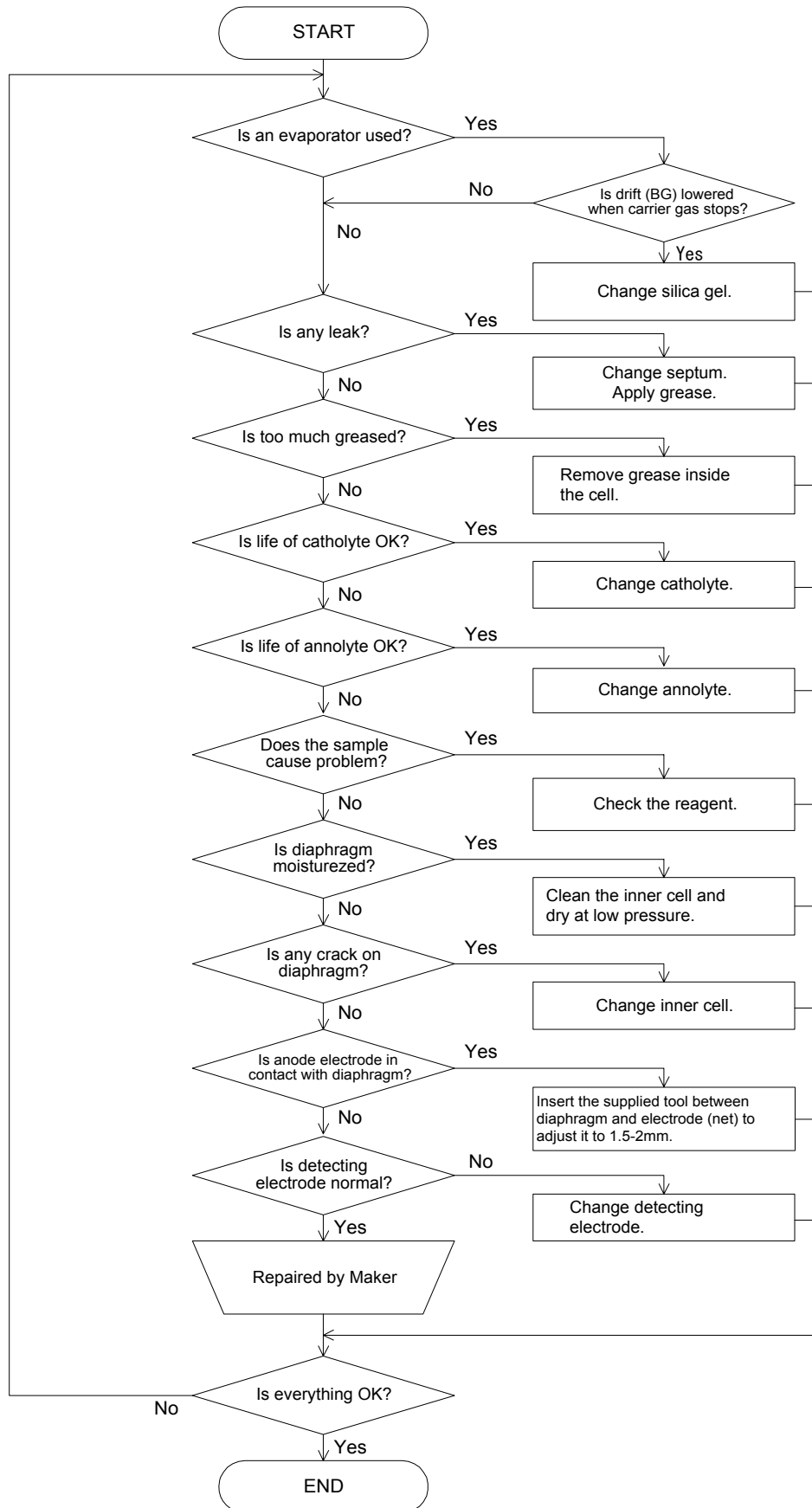



## 6. Others

### 6-1. Parts list

– Consumable parts · Maintenance parts –

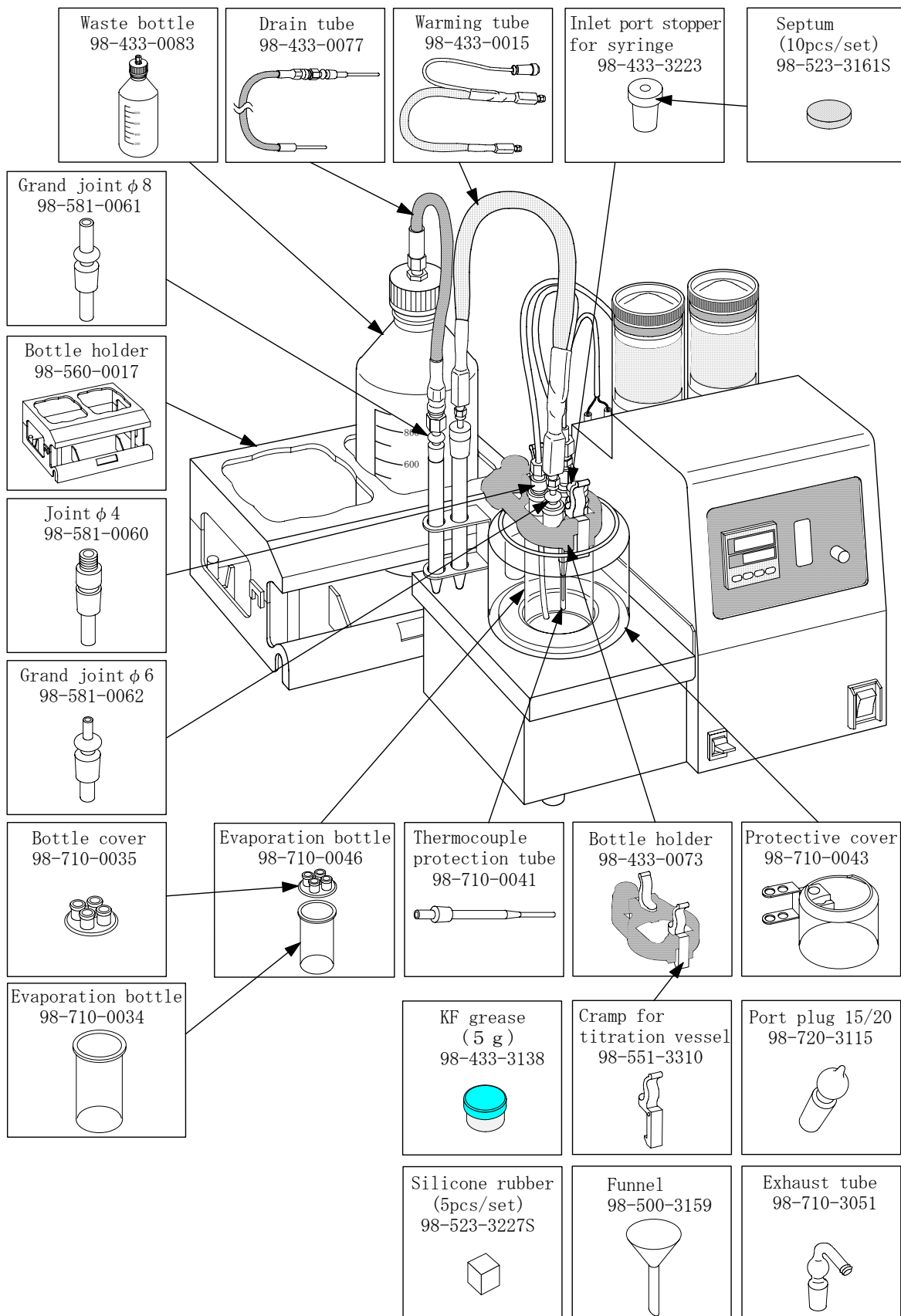

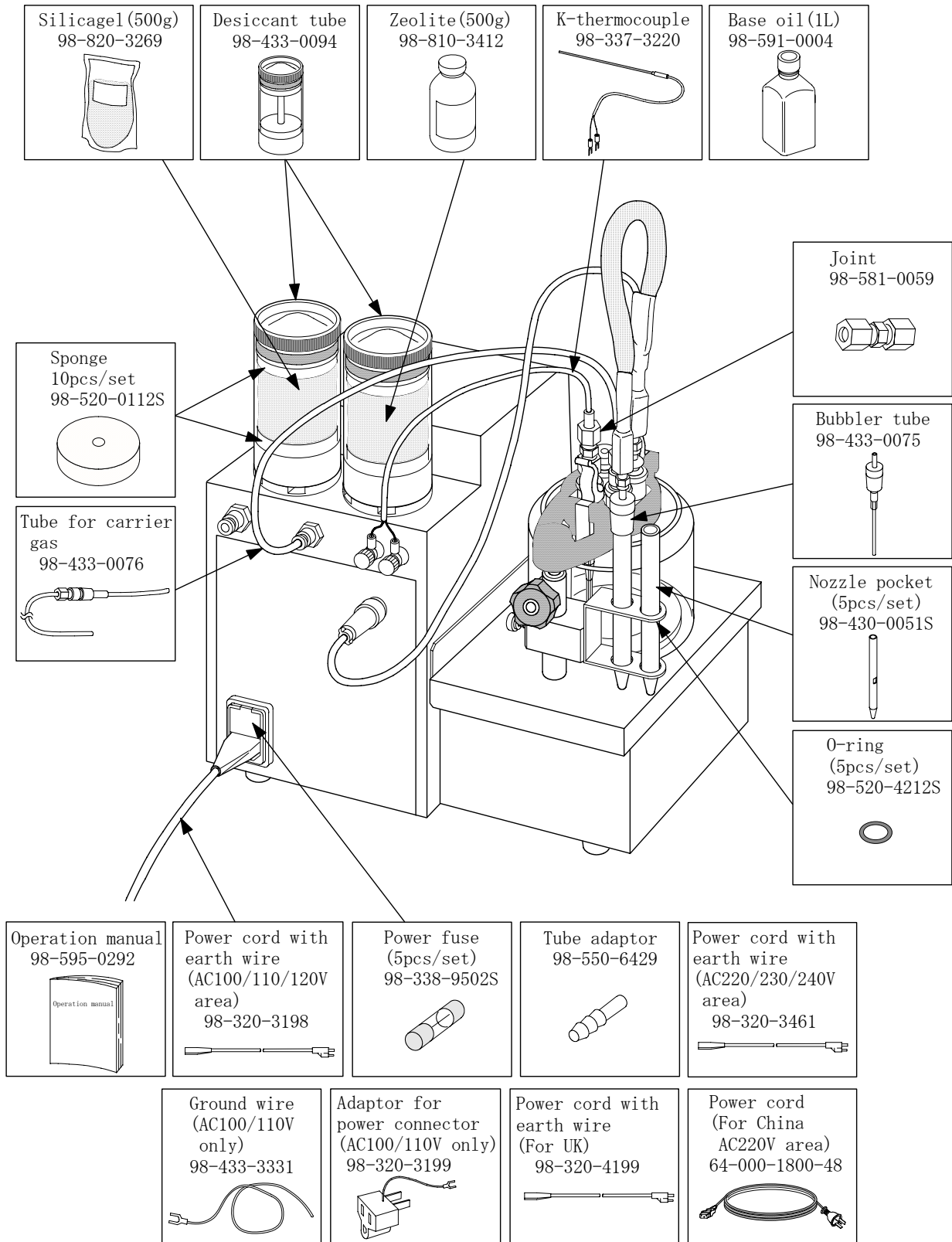

-Option-

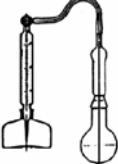
Part code	Part name	Remark	Sketch
98-740-3013	Oil sampler		

## 6-2. Flow chart

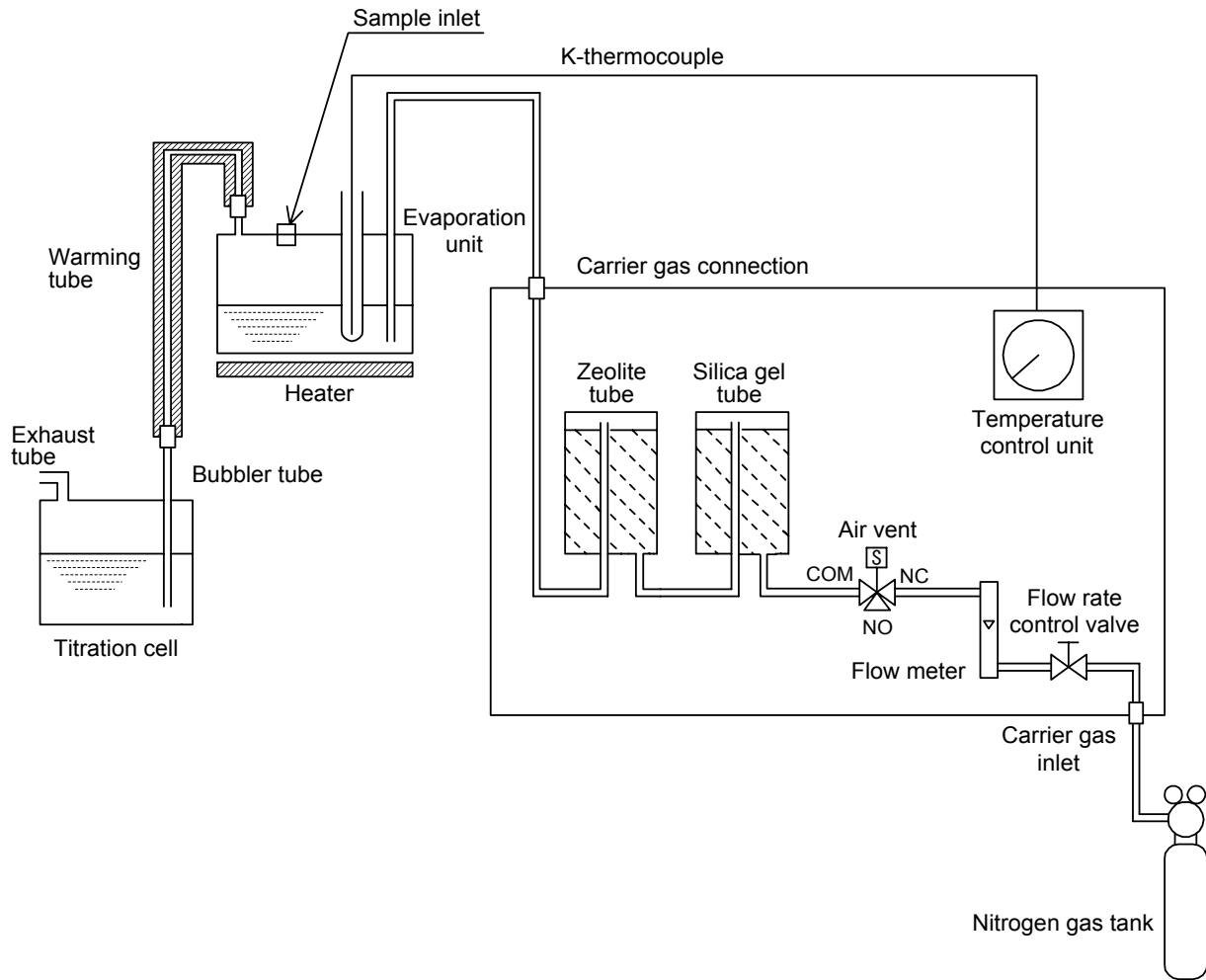

### 6-3. Technical data

Technical item	Description
Type and model	ADP-513 Evaporator for Oil Sample
Heating method	Cartridge base heater
Temperature range	Room to 200°C Minimum step 1°C
Temperature control	PID control by CPU
Gas flow rate	100 to 300mL/min (Typical 200mL/min)
Over heating protection	By thermal fuse
Ambient conditions	Temperature : 5 to 35°C Humidity : less than 85%RH
Carrier gas	Nitrogen gas (not included)
Power	AC100 to 120V±10% 50/60Hz 400W AC200 to 240V±10% 50/60Hz 400W Set in plant before shipment
Dimension	Main unit 320(W)× 210(D) ×330(H)mm
Weight	Approximately 6kg

## 6-4. Warranty and after-sale service

1. The product you have purchased passed standard test and inspection in plant before shipment. Quality of the product is covered by one-year warranty except consumable parts.  
Some conditions or performance in use may not be covered even when the product is in the warranty period.
2. For repair or maintenance servicing, please contact your local dealer or distributor where you purchased the product.
3. Before you call the dealer, read the manual (“4. Maintenance” and “5. Troubleshooting”) and recheck the trouble.

When you contact your dealer, please notify:

Production No. of your instrument  
Details of the trouble  
Person to contact

4. Parts and consumables can be purchased from your dealer. Parts for discontinued model will be supplied for further seven years.
5. This warranty does not cover claims caused by any of the followings:
  - 1) Modification by unauthorized person
  - 2) Splashed by or dipped in water (the product is not waterproof.)
  - 3) Use under condition or range other than specified
  - 4) Operated in other method than specified in the manual
  - 5) Dropped or given physical shock
  - 6) Erroneous handling or misuse
  - 7) Use under extraordinary environmental condition
  - 8) Caused by fire, earthquake, lightning or Act of God
6. The manufacturer, dealer or distributor of the product will not be responsible for any loss or damage, whether economical or physical, related directly or indirectly in use of the product.

**KEM** KYOTO ELECTRONICS  
MANUFACTURING CO., LTD.

Overseas Division: Yamawaki Bldg 9F 4-8-21 Kudan Minami,  
Chiyoda-ku, Tokyo 102-0074 JAPAN  
FAX: +81-3-3237-0537, Phone: +81-3-3239-7333  
E-mail: [export@kem.co.jp](mailto:export@kem.co.jp) URL: <http://www.kyoto-kem.com>  
Factory: 56-2 Ninodan-cho, Shinden Kisshoin, Minami-ku, KYOTO  
601-8317, JAPAN

FAX: +81-75-691-9961, Phone: +81-75-691-4122

E-mail: [tech-english@kem.co.jp](mailto:tech-english@kem.co.jp)