

BOMB RESPONSE VEHICLES.
CHOOSE YOUR ULTIMATE
LEVEL OF PERFORMANCE.



PIERCE
BOMB RESPONSE VEHICLES



When you choose a Pierce® Bomb Response Vehicle, you're choosing to build an apparatus around the needs of your department - not your neighbor's.

In listening to your apparatus requirements, Pierce helps determine if one of 500 standard compartment configuration lengths will meet these needs. If not, we will customize your apparatus, making a one-of-a-kind configuration for your specific application.

Your Pierce Bomb Response Vehicle can be configured on a commercial grade chassis or any one of five Pierce custom chassis, giving you a sole source vehicle build.

This customization and extensive option availability allows you to build an apparatus that meets your department's requirements today, as well as the service you demand in the future.



High performance comes from choice.
Choice comes from Pierce.
PIERCE BOMB RESPONSE VEHICLES.

ENDLESS COMBINATIONS. UNLIMITED POTENTIAL.

BOMB RESPONSE VEHICLES.



PIERCE
BOMB RESPONSE VEHICLES

CHASSIS

Commercial 2 Door Chassis

Overall Height: 11' 4" (3 m 454 mm)

Overall Length: 31' 7.63" (9 m 194 mm)

Cab Configuration: 2 door commercial cab

Wheelbase: 209.00" (5309 mm)

GVW Rating: 35,000 lbs. (15876 kg)

Front Axle: Meritor 12,000 lb. (5443 kg) spring

Rear Axle: Meritor 23,000 lb. (10443 kg) spring

Engine: MaxxForce 350 HP

Transmission: Allison EVS 3000

Bumper: 13.00" (330 mm) extended

Alternator: 320A Leece-Neville

BODY

Material: Aluminum

Length: 20.5' (6.2 m)

Height: 118.25" (3004 mm) body, 83.25" (2115 mm) interior

Access: Passenger-side entry door

Door Type: Gortite roll-up doors

Roof Configuration: Integrated hatch storage

Interior Configuration:

- One fold-down seat
- Three 120V roof mounted A/C units
- 12V red/clear LED lighting
- Two robot control stations with 26" (660 mm) monitors
- One full height bomb suit storage cabinet
- Custom aluminum vented cabinets throughout
- Rear robot storage area
- Recessed floor tie downs and side tie down tracks
- Video distribution system including one Nuvico four-channel DVR, one 42" (1067 mm) monitor and two 26" (660 mm) monitors

Exterior Body:

- Passenger-side electric awning
- Onan Quiet 12kW diesel generator
- Whelen LED lighting package
- 12V Pioneer LED scene lights
- Full width rear aluminum lift gate

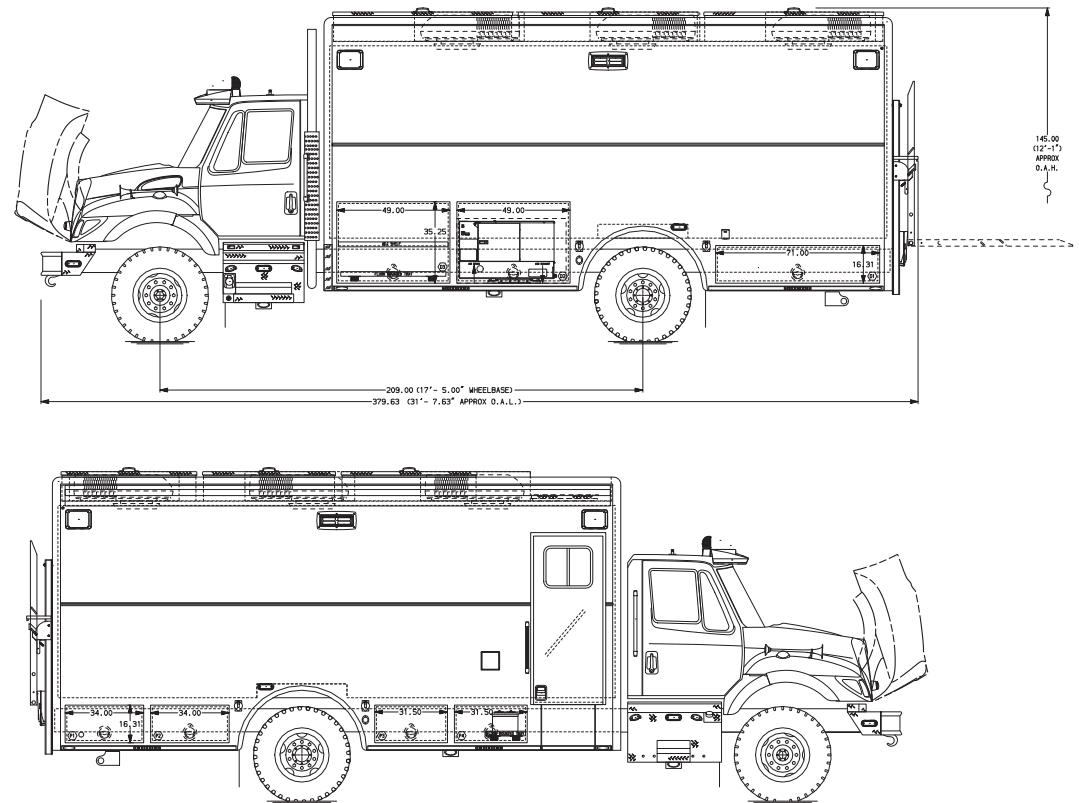

piercemfg.com

920 832 3000

All metric conversions are approximations.