

HOSEBED CAPACITIES  
 ① 1000' OF 4.00" D.J. HOSE  
 ② 400' OF 2.50" D.J. HOSE

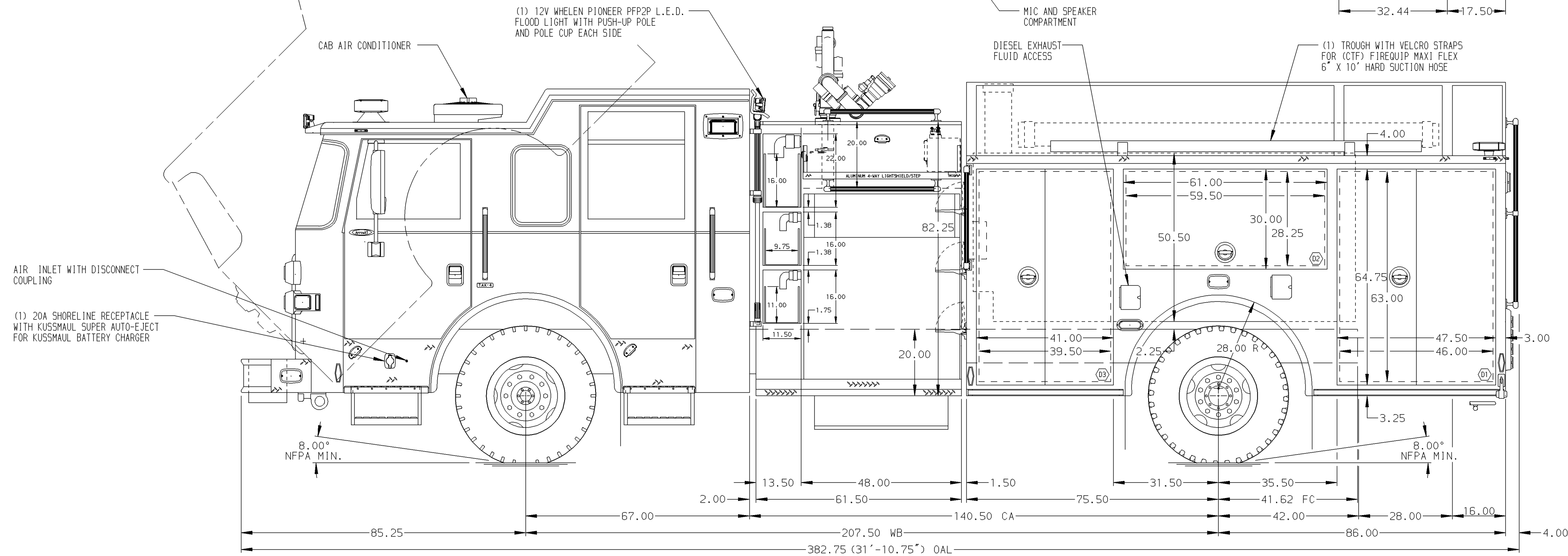
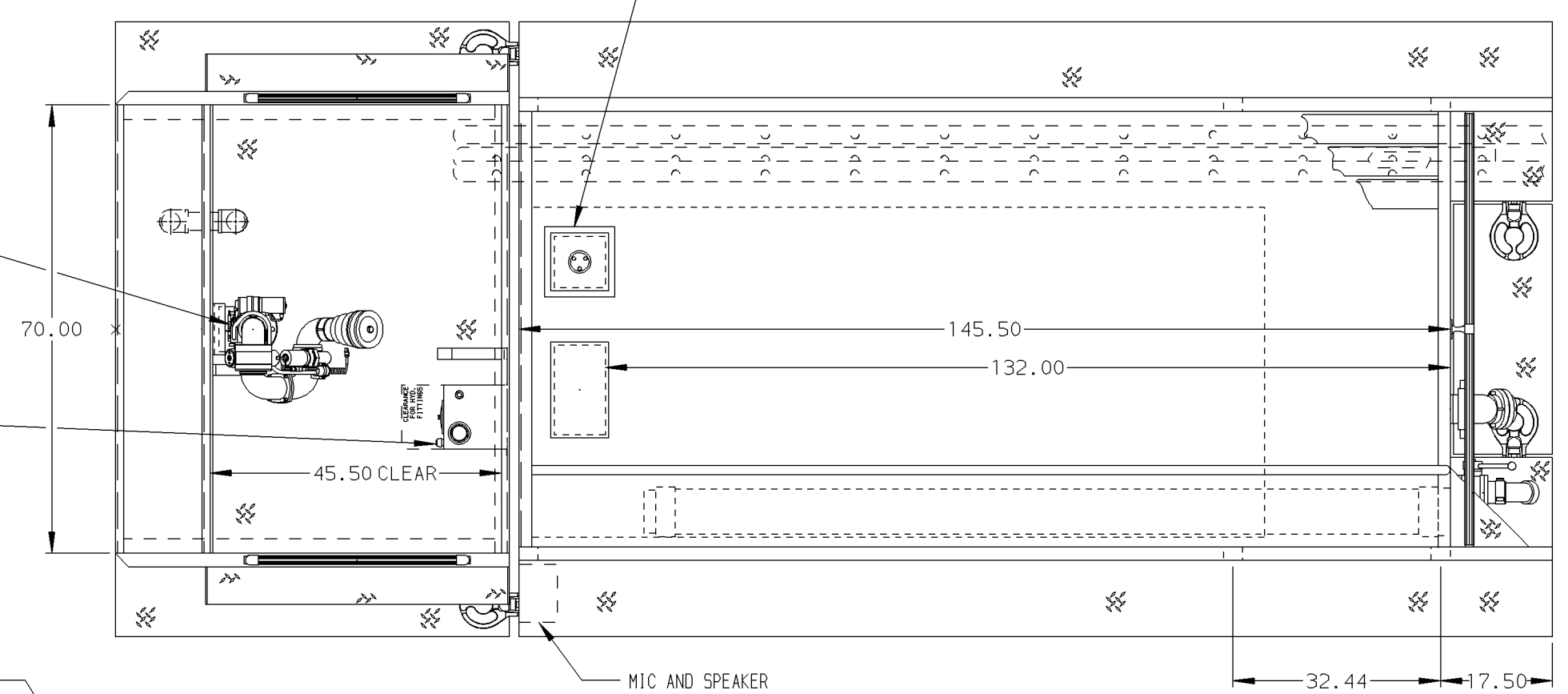

**STAINLESS STEEL BODY**

**NOTE**  
 DIMENSIONS SHOWN ARE APPROXIMATE AND ARE SUBJECT TO MINOR DEVIATIONS AS MAY OCCUR OR BE NECESSARY IN CONSTRUCTION. MINOR DETAILS NOT SHOWN.

1. QNSPOT AUTOMATIC TIRE CHAINS TO BE PROVIDED AT REAR
2. WOGEL LUBE SYSTEM PUMP LOCATED PER SHOP ORDER
3. ALUMINUM TREADPLATE EXTERIOR REAR WALL OF CAB
4. MOUNTING BASE FOR ANTENNA LOCATED PER SHOP ORDER
5. KUSSMAUL 1000 BATTERY CHARGER LOCATED IN COMPARTMENT D3
6. BATTERY CHARGER INDICATOR LOCATED NEAR D.S. SEAT RISER WITH BRACKET
7. PERIMETER SCENE LIGHTS LOCATED PER SHOP ORDER
8. 5/STL SCUFFPLATE ON BOTTOM EDGE OF DOOR FRAMING OF COMPARTMENTS D1, D2, D3, P1, P2 & P3
9. 5/STL SCUFFPLATE INTERIOR OF DOOR IN COMPARTMENTS D2, D3 & P3
10. DRIP PAN GUARD FOR ROLL-UP DOOR LOCATED IN COMPARTMENT R1
11. PIERCE L.E.D. DUAL COMPARTMENT LIGHT STRIPS LOCATED PER SHOP ORDER
12. PAINTED SHELF TRACKS LOCATED IN COMPARTMENTS D1, D3, P1, P2, P3 & R1
13. ONE FULL WIDTH/DEPTH PAINTED ADJUSTABLE SHELF IN COMPARTMENTS D1, P1, P2, P3 & R1; TWO IN D3
14. ONE FLOOR MOUNTED SLIDE-OUT TRAY WITHOUT SIDES IN COMPARTMENT R1
15. ONE ADJUSTABLE SLIDE-OUT TRAY IN COMPARTMENTS D3 & P3
16. ONE PAINTED SWING-OUT TOOL BOARD WITH PEGBOARD PATTERN IN COMPARTMENT D2
17. TURTLE TILE MATTING WITH RAMP ON FLOORS OF COMPARTMENTS D1, D2, D3, P1, P2 & P3
18. TURTLE TILE MATTING ON ALL SHELVES AND TRAYS
19. ALL FOLDING STEPS TO BE TRIDENT WITH INTEGRATED L.E.D. LIGHT UNLESS SPECIFIED
20. STAINLESS STEEL FENDER CROWNS FRONT AND REAR
21. PIERCE LOGO MUDFLAPS FRONT AND REAR
22. MUDFLAPS FORWARD OF REAR WHEELS
23. TWO ZIAMATIC SAC-44-E FOLDING WHEEL CHOCKS LOCATED AT PICKUP
24. HUSKY 12 SINGLE AGENT FOAM SYSTEM
25. HOT WATER HEATER WITH SHUT OFF VALVES

		JOB NO.	28009
		SCALE	DATE
TITLE 1500-D-1000P W/25 GAL FOAM CELL, 161" FH FDLER BODY (3) SPEEDLAYS, LADDERS BESIDE TANK, DELUGE		DRAWN BY	NPA 08JUL14
FOR STRATTON MOUNTAIN FIRE DEPARTMENT STRATTON, VERMONT		CHECKED BY	CSH 08JUL14
DWG NO. 28009AD		SHEET SIZE	SHEET NO. 1 OF 1

REV	DATE	BY	CH	ARROW-XT
1	19SEP14	NPA	DTS	
2	28AUG14	NPA	DTS	