

HOLLOSHAFT® Motors

Vertical A.C. Motors, High Thrust



Horsepower: 3 – 5000 HP

Speeds: 3600 – 400 RPM

Design Voltages: Three Phase/208-6900 Vac/50 or 60 Hz

Enclosures: Weather Protected Type I, Weather Protected Type II, Totally Enclosed Fan Cooled, and Hazardous Location

Efficiency Levels: Standard Efficient, Energy Efficient, and Premium Efficient



Product Overview and Options

The U.S. MOTORS® brand Vertical HOLLOSHAFT® motor has been a standard in the pumping industry since 1922. These motors are recognized for their longevity, reliability and ease of use. Unique configurations, tailored to a customer's specific requirements, can include enclosure design to minimize the effects of adverse conditions present in turbine, mix flow and propeller pump applications.

U.S. MOTORS® brand Vertical HOLLOSHAFT® motors are constructed of high quality materials and are manufactured in a state-of-the-art, ISO9000-2000 facility. Innovative, performance-focused design makes this motor the most trusted in the industry.

Product Features:

- Class F insulation, Class B rise at full load
- 1.15 Service Factor - typical for WPI and WP II enclosures
- 1.00 Service Factor - typical for TEFC and hazardous location enclosures
- Maximum 40°C ambient, 3,300 feet altitude
- Bearing capacities among highest in industry
- Multiple bearing configurations available for specific bearing life requirements.
 - Ball
 - Spherical Roller
 - Angular Contact
 - Plate Type



WPI 15-4000 HP
and WP II 300-5008 HP

Typical HOLLOSHAFT® Motor Construction:

- 1. Lightweight Top Cover**
- 2. Coupling** is readily accessible
- 3. Lockbar** holds shaft during adjustments
- 4. Lifting Lugs** positioned for stability
- 5. Protected Air Openings** exceed NEMA WPI requirements
- 6. Precision Machined Mounting Base**, ample clearance for mounting bolt installation
- 7. Rugged Bearing** withstands heavy load thrusts
- 8. Large Plug** simplifies oil fills
- 9. Sight Gauge Window** for quick oil level reading
- 10. Metered Oil Flow** minimizes churning
- 11. Dual Air Flow** system for uniform cooling of motor top and bottom
- 12. Windings** Protected by new, synthetic materials
- 13. Solid Die Cast Rotor** with integral fan blades

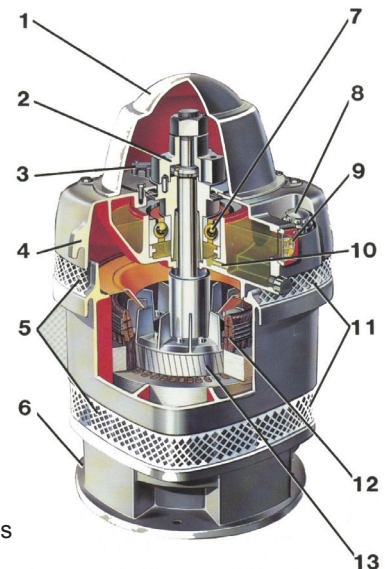

Enclosure Types

Non-Reverse Backstop Ratchet Design, BALL-O-MATIC®

- First technology of its kind in the market
- Prevents reverse rotation within 4.5 degrees of rotation
- Unlimited depth setting
- Can be used in certain Hazardous Location applications

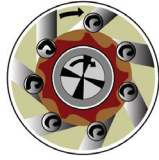

BALL-O-MATIC®
Backstop Ratchet

Weather Protected Type I (WPI)

Constructed to minimize the entrance of rain, snow and airborne particles. Enclosures exceed NEMA requirements. The ventilation system is designed to provide optimum cooling to the thrust bearing and electrical components and is available in all motor sizes.

Weather Protected Type II (WPII)

Enclosure offers protection against hostile outdoor environments. The special ventilation system minimizes the entrance of high velocity air, moisture and airborne particles into the motor's passages.

4 Zone Design

U.S. MOTORS® brand vertical pump motors are designed with four functional zones. This design ensures easy installation and service and provides operator protection and convenience.

ZONE 1

Canopy cap allows easy access to the coupling, non-reverse ratchet and thrust bearing.

ZONE 2

Thrust bearings, generously sized oil reservoir, and large weather-protected air intake for continuous cooling to the motor and thrust bearings.

ZONE 3

Winding section develops the driving torque and houses the insulation systems.

ZONE 4

Compact mounting base designed for momentary upthrusts of the pump.

Unique design allows the use of standard internal components. Special enclosures can be adapted with minimum delay.

Totally Enclosed Fan Cooled (TEFC) and Hazardous Location

Non-sparking, non-reverse ratchet design. Available for severe environments where destructive dusts, vapors and other harmful substances are found. Perfect for use in hazardous locations where Underwriters Laboratories (UL®†) approval is necessary.

CORRO-DUTY®

Cast iron CORRO-DUTY® motors are available with external corrosion-resistant paint and hardware for extremely harsh environments.



TEFC and Hazardous
Location 3-700 HP

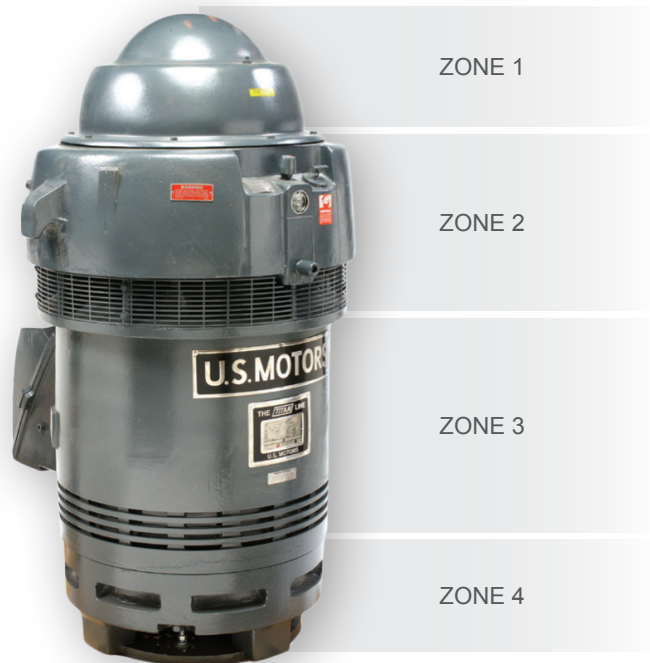

WPI 15-4000 HP
and WPII 300-5008 HP

† All marks shown within this document are properties of their respective owners.

Nidec Motor Corporation, 2012; All Rights Reserved. U.S. MOTORS® is a registered trademark of Nidec Motor Corporation. Nidec Motor Corporation trademarks followed by the ® symbol are registered with the U.S. Patent and Trademark Office.

Nidec
NIDEC MOTOR CORPORATION

8050 W. Florissant Avenue | St. Louis, MO 63136
Phone: 888-637-7333 | Fax: 866-422-7758