







Package Contents

TOUCH MONITOR 	WIRELESS MONITOR REMOTE CONTROL 	MONITOR POWER CABLE 	TOUCH USB CABLE FROM MONITOR 	TOUCHSCREEN POWER SUPPLY 	VGA VIDEO CABLE 
--	--	--	---	---	--

Missing any of these items? Please contact Horizon Display at (888)737.4674 or email support@horizondisplay.com

Connecting and Turning on the Touch Unit

1. Connect the video cable from the computer's video port to the monitor's video in port.
2. Connect the Touchscreen Power Supply from the touchscreen power connector to a power source.
3. Connect the Touchscreen USB Cable from the touchscreen USB connector to the computer's USB port.
4. Connect the monitor's power cable from the monitor's AC IN port and to a power source.
5. Turn the monitor on. Make sure to set the Vacation Power Switch to the ON position. It is usually located beside the AC IN port.
6. Turn on the computer.

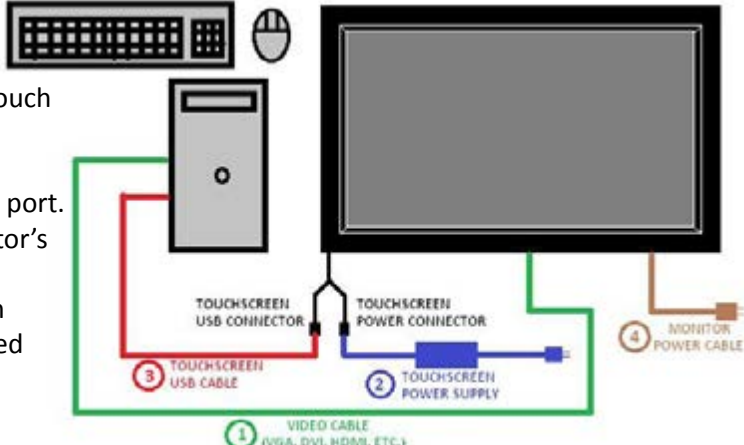

Calibrating your Touch Monitor

1. Download and install the latest PQ Labs touchscreen driver for your computer. Go to <http://www.horizondisplay.com/Support>, click on "Drivers" then look for "PQ Labs LED Cell Imaging Touchscreen Driver, Control Panel and Calibration Utility".
2. Open the PQ Labs Multi-touch Platform utility then click on the "Calibration" button.
3. Follow the on-screen instructions.
4. Click OK to close the utility and save the changes.
5. Test the calibration by moving your finger around the screen while examining how closely the mouse cursor follows your finger. If the calibration is not satisfactory, please recalibrate the touch monitor.

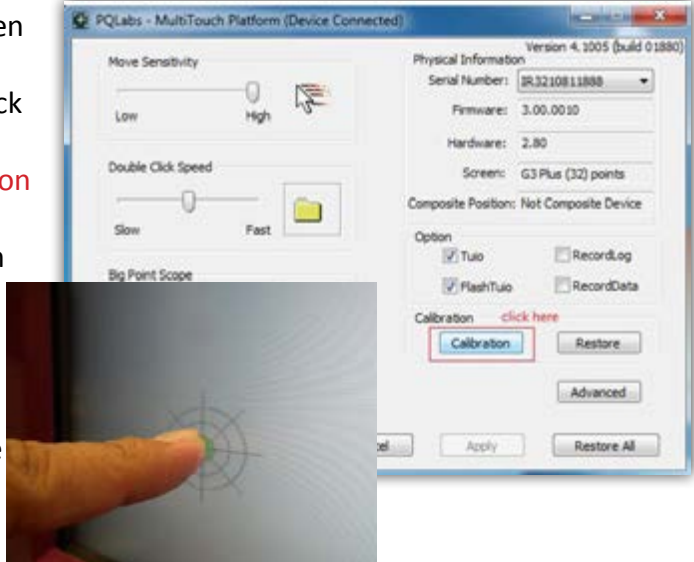

How Do I Get Support?

Step 1. Try our website for troubleshooting tips at www.horizondisplay.com/support
 Step 2. Contact Horizon Display at (888)737.4674 or email support@horizondisplay.com
 Support Hours: Mon-Fri 9-5PM PST. Please have the unit's model # and serial ready when making the call to Horizon Display