

The art of service!



GESAMTSORTIMENT | 2016 • 2017
COMPLETE RANGE • GAMME GÉNÉRALE

HEPP. Über 150 Jahre Erfolgsgeschichte.

HEPP. A story of success for over 150 years.



1863

Gründung der Spezialfabrik für Bestecke und Serviergeräte

The founding of the dedicated cutlery and serving utensil factory



1913

Jubiläum 50 Jahre Gebrüder Hepp

The anniversary of 50 years of "brothers Hepp"

Carl Hepp, der Chemiker, erfindet das Hotel-Silber

The chemist Carl Hepp establishes hotel silverware



1931

Verkauf des Unternehmens an Familie Frank

Sale of the company to the Frank family



1945

Zerstörung im Zweiten Weltkrieg

Destruction in the Second World War

1948

Wiederaufbau der Fabrikation

Manufacturing is re-established



Historische HEPP Werkhalle

Historical HEPP factory



1951

1963

1980

1990

2006

2013

2017

Jubiläum
100 Jahre HEPP
The anniversary of
100 years of HEPP

Brandkatastrophe
Fire disaster

Jubiläum 150 Jahre HEPP
The anniversary of
150 years of HEPP

Fertigstellung des
neuen Fabrikgebäudes
in Pforzheim

Completion of the
new factory building
in Pforzheim

Einweihung des Fabrikations-
und Verwaltungsgebäudes in Birkenfeld

Inauguration of the new manufacturing
and administration building in Birkenfeld

HEPP wird eine Marke
der proHeq GmbH

HEPP becomes a brand
of proHeq GmbH



Verkaufsausstellung
in den 60er Jahren

Sales exhibition
in the 1960's

Moderne Produktionstechnologie

Modern production technology



Für die besten Adressen weltweit For the best locations worldwide



Glanzstücke für die Tafelkultur und professionelles Equipment

HEPP zählt zu den bedeutendsten Anbietern rund um den gedeckten Tisch und ist Marktführer in Bezug auf Angebotsvielfalt. In einer hochmodernen Fertigung für Tafel- und Serviergeräte werden hunderte von Artikeln hergestellt: Vom Besteck über Kaffeekännchen bis hin zu Chafing Dishes und Speisenverteilensystemen. Ein etabliertes Vertriebs-Partnernetzwerk sorgt für professionelle Beratung rund um den Globus.

Seit 1863 hat sich HEPP einen Namen in der gehobenen Gastronomie und Hotellerie gemacht. Der Erfolg setzt sich – damals wie heute – aus traditionellen Werten wie Zuverlässigkeit und Qualität, sowie Innovationskraft und Flexibilität zusammen.

Showpieces for fine dining and professional equipment

HEPP ranks among the most important suppliers in the field of tableware and is the market leader with regard to its wide range of products. In a highly modern production line for hollowware and flatware hundreds of articles are manufactured: From cutlery through coffee jugs to chafing dishes and food distribution systems. An established distribution and partner network ensures professional advice around the globe. Since 1863 HEPP has made their name in the upmarket catering and hotel business.

The success – then as now – is founded on traditional values such as reliability and quality, as well as innovative drive and flexibility.



In der Luft, zu Wasser und zu Lande.
Eine Klasse für sich.

HEPP-Produkte sorgen für gepflegte Gastlichkeit bei Kunden in über 90 Ländern rund um den Globus. Darunter finden sich Top-Namen aus der Hotel- und Gastronomiewelt, sowie namhafte High Class-Hotels weltweit.

In the air, on land and sea.
A class of its own.

HEPP products provide sophisticated hospitality in over 90 countries throughout the world. They include top names from the world of catering, as well as high class hotels worldwide.



Kollektionen · Collections

VISION





PROFILE

Die Kollektionen von HEPP werden als Kreativkomponenten für die Tischkultur entwickelt.

Ob für Bar, Buffet oder den gedeckten Tisch, neben sämtlichen Basisteilen bieten die HEPP-Kollektionen auch Accessoires für die Erfordernisse einer großen Tafel. Auffälligstes Gestaltungsmerkmal sind die designten Griffe, Knöpfe und Füße – die prägnante Formgebung der Kollektionen spiegelt sich in allen Teilen wieder. Bei jeder Kollektion unterstreichen konsequente Linienführung und funktionelle Details die exklusive und moderne Eleganz.



EXCELLENT

The collections from HEPP have been developed as creative components for fine dining culture.

Whether for the bar, buffet or a table setting, the HEPP collections also provide accessories for the requirements of a large table, besides the complete basic pieces. The most striking design characteristics are the designed handles, knobs and feet – the remarkable shapes of the extraordinary collections are reflected in all the pieces. In each collection the consistent use of lines and functional details emphasize the exclusive and modern elegance.

Sonderkollektionen · Special Collections

Weitere Informationen finden Sie online unter www.hepp.de.

You can find more information online: www.hepp.de.

ARTE



EXCLUSIVE



Zeitlos schönes Design
Timeless, beautiful design





Design, Qualität und Individualisierung

HEPP versteht sich als Anbieter von Markenprodukten, die in Gestaltung, Qualität und Gebrauchsnutzen höchsten Ansprüchen gerecht werden. Von der Idee bis zum fertigen Produkt und im täglichen Gastronomieinsatz – Material und Verarbeitung stehen im Vordergrund. Als Erfinder des Hotel-Silbers stützt sich die Marke HEPP auf diese Grundsätze. Die zeitlos schönen Tafelgeräte werden von HEPP auch nach Ihren Wünschen veredelt und individuell gestaltet.

Design, Quality and Customizing

HEPP regards itself as a supplier of brand products that meet the highest demands of design, quality and product use. From the conception to the finished product and in day-to-day handling in catering – the focus is on the material and workmanship. As the inventor of hotel silverware, the brand HEPP is based on these principles. According to your wishes the timeless table appliances are refined and customized by HEPP – for example by customizing your flatware with an engraving or stamp.



HEPP ist nach DIN ISO 9001-2008 zertifiziert

HEPP is certified in accordance with DIN ISO 9001-2008



Inhalt · Content





Besteck · Cutlery	12
Besteckmodelle · Cutlery models	
Besteckergänzungsteile · Cutlery additional pieces	
Besteckständer · Cutlery holder	
Frühstück · Breakfast	62
Dispenser · Dispenser	
Universalständer · Multi purpose stand	
Heißgetränke · Hot drinks	
Serviergeräte · Serving utensils	
Gebäck · Pastry	
Afternoon Tea Etagere · Afternoon Tea stand	
Menü & Bankett · Menu & Banquet	98
Menü & Bankett · Menu & Banquet	
Edel Food · Exclusiv Food	
Würzen · Seasoning	
Tisch-Accessoires · Table Accessoires	
Chafing Dish & Buffet	128
Sequence	
Induction Plus	
Chafing Dish	
Chafing Dish Zubehör · Chafing Dish accessory	
Buffet	
Kaltgetränke & Bar · Cold Drinks & Bar	182
Wein · Wine	
Kaltgetränke · Cold drinks	
Bar	
Sonderkollektionen · Special collections	196
Arte	
Exclusiv	
Servierwagen · Serving trollies	200
Pflege · Maintenance	222
Reparaturservice · Repair service	
Poliermaschine · Burnishing machine	
Pflege · Maintenance	
Index A-Z	236

Stilvolle Gastlichkeit beginnt beim Besteck
Stylish hospitality starts with cutlery





BESTECKE · CUTLERY

ÜBERSICHT BESTECKMODELLE · OVERVIEW CUTLERY MODELS



PARTUM

Seite · Page 16



PROFILE

Seite · Page 18



BAGUETTE

Seite · Page 20



ECCO

Seite · Page 22



CONTOUR

Seite · Page 24



CARLTON

Seite · Page 26



AURA

Seite · Page 28



ROYAL

Seite · Page 30



LENTO

Seite · Page 32

WEITERE BESTECKMODELLE · MORE CUTLERY MODELS:
PREMIUM Seite · Page 52 TREND Seite · Page 54

ERGÄNZUNGSTEILE · CUTLERY ADDITIONAL PIECES Seite · Page 56



KREUZBAND

Seite · Page 34



TALIA

Seite · Page 36



STYLE

Seite · Page 38



MEDAN

Seite · Page 40



DIAMOND

Seite · Page 42



ACCENT

Seite · Page 44



CHIPPENDALE

Seite · Page 46



EMOTION

Seite · Page 48



EXCLUSIV

Seite · Page 50



56.1201.6040
56.1201.6030

Menüöffel
Table spoon
Cuiller de table
217 mm · 8½ in.



56.1202.6040
56.1202.6030

Menügabel
Table fork
Fourchette de table
215 mm · 8½ in.



56.1203.6049
56.1203.6039

Menümesser
Table knife
Couteau de table
237 mm · 9¼ in.



56.1204.6040
56.1204.6030

Vorspeisenlöffel
Dessert spoon
Cuiller à dessert
199 mm · 7¾ in.



56.1205.6040
56.1205.6030

Vorspeisengabel
Dessert fork
Fourchette à dessert
197 mm · 7¾ in.



56.1206.6049
56.1206.6039

Vorspeisenmesser
Dessert knife
Couteau à dessert
221 mm · 8¾ in.



56.1207.6040
56.1207.6030

Kaffeelöffel
Coffee spoon
Cuiller à café
136 mm · 5½ in.



56.1209.6040
56.1209.6030

Moccalöffel
Demi-tasse spoon
Cuiller à moka
108 mm · 4½ in.



56.1210.6040
56.1210.6030

**Vorspeisen-/
Dessertlöffel**
Dessert spoon
Cuiller à dessert
156 mm · 6¼ in.



56.1235.6040
56.1235.6030

Fischgabel
Fish fork
Fourchette à poisson
184 mm · 7¼ in.



56.1236.6040
56.1236.6030

Fischmesser
Fish knife
Couteau à poisson
206 mm · 8¼ in.



56.1264.6040
56.1264.6030

Kuchengabel 3-zinkig
Cake fork
Fourchette à gâteau
157 mm · 6¼ in.



56.1266.6049
56.1266.6039

Buttermesser²⁾
Butter knife
Couteau à beurre
170 mm · 6¾ in.



56.1272.6040
56.1272.6030

Limonadenlöffel
Iced tea spoon
Cuiller à soda
220 mm · 8¾ in.



56.1275.6040
56.1275.6030

**Vorspeisen-/
Dessertgabel 4-zinkig**
Dessert fork
Fourchette à dessert
157 mm · 6¼ in.



56.1286.6049
56.1286.6039

Obstmesser
Fruit knife
Couteau à fruits
175 mm · 6⅞ in.



56.1289.6040
56.1289.6030

Tassenlöffel
Round soup spoon
Cuiller à bouillon
166 mm · 6½ in.

Besteck-Einzelteile
Serving pieces
pièces à servir

18/10
18/10
18/10

versilbert
silver plated
argenté

rostfreier Stahl
stainless steel
acier inoxydable

rostfreier Stahl versilbert
stainless steel silver plated
acier inoxydable argenté

56.12XX.6040

56.12XX.6030

56.12XX.6049

56.12XX.6039

¹⁾ Hohlheft (18/10)
hollow handle (18/10)
orfèvre (18/10)

²⁾ ohne Wellenschliff
without serrated blade
sans lame crantée

³⁾ Designvariante
alternative design
variante de design





01.0048.1010
03.0148.3010

Esslöffel
Table spoon
Cuiller de table
206 mm · 8¹/₈ in.



01.0048.1020
03.0148.3020

Essgabel
Table fork
Fourchette de table
208 mm · 8³/₁₆ in.



01.0048.1800
03.0148.3800

Tafelmesser
Table knife
Couteau de table
230 mm · 9¹/₁₆ in.



06.0048.1980
08.0148.3980

Tafelmesser³⁾
Table knife
Couteau de table
230 mm · 9¹/₁₆ in.



01.0048.1050
03.0148.3050

Dessertlöffel
Dessert spoon
Cuiller à dessert
183 mm · 7³/₁₆ in.



01.0048.1060
03.0148.3060

Dessertgabel
Dessert fork
Fourchette à dessert
185 mm · 7⁵/₁₆ in.



01.0048.1810
03.0148.3810

Dessertmesser
Dessert knife
Couteau à dessert
202 mm · 7¹⁵/₁₆ in.



06.0048.1990
08.0148.3990

Dessertmesser³⁾
Dessert knife
Couteau à dessert
202 mm · 7¹⁵/₁₆ in.



01.0048.1100
03.0148.3100

Kaffelöffel
Coffee spoon
Cuiller à café
140 mm · 5¹/₂ in.



01.0048.1110
03.0148.3110

Moccalöffel
Demi-tasse spoon
Cuiller à moka
110 mm · 4⁴/₁₆ in.



01.0048.1140
03.0148.3140

Fischmesser
Fish knife
Couteau à poisson
205 mm · 8¹/₁₆ in.



01.0048.1150
03.0148.3150

Fischgabel
Fish fork
Fourchette à poisson
185 mm · 7³/₁₆ in.



01.0048.1210
03.0148.3210

Limonadenlöffel
Iced tea spoon
Cuiller à soda
193 mm · 7⁷/₈ in.



01.0048.1270
03.0148.3270

Universal-Löffel-Gabel
Comb. Spoon-Fork
Cuiller-Fourch. univ.
184 mm · 7¹/₄ in.



01.0048.1330
03.0148.3330

Buttermesser²⁾
Butter knife
Couteau à beurre
170 mm · 6¹¹/₁₆ in.



01.0048.1580
03.0148.3580

Franz. Saucenlöffel
French sauce spoon
Cuiller à sauce française
182 mm · 7³/₁₆ in.



01.0048.1630
03.0148.3630

Runder Suppenlöffel
Round soup spoon
Cuiller rond à bouillon
182 mm · 7³/₁₆ in.



01.0048.1740
03.0148.3740

Nachspeisenlöffel
Dessert spoon
Cuiller à dessert
154 mm · 6¹/₁₆ in.



01.0048.1750
03.0148.3750

Nachspeisengabel
Dessert fork
Fourchette à dessert
155 mm · 6¹/₈ in.



06.0048.1890
08.0148.3890

Buttermesser²⁾
Butter knife
Couteau à beurre
165 mm · 6¹/₂ in.



01.0048.1950
03.0148.3950

Steakmesser
Steak knife
Couteau à steak
234 mm · 9³/₁₆ in.

Besteck-Einzelteile
Serving pieces
pièces à servir

18/10
18/10
18/10

versilbert
silver plated
argenté

rostfreier Stahl
stainless steel
acier inoxydable

rostfreier Stahl versilbert
stainless steel silver plated
acier inoxydable argenté

01.0048.1XX0

03.0148.3XX0

06.0048.1XX0

08.0148.3XX0

¹⁾ Hohlheft (18/10)
hollow handle (18/10)
orfèvre (18/10)

²⁾ ohne Wellenschliff
without serrated blade
sans lame crantée

³⁾ Designvariante
alternative design
variante de design



BAGUETTE



BAGUETTE



01.0032.1010
03.0132.3010

Esslöffel
Table spoon
Cuiller de table
205 mm · 8¹/₁₆ in.



01.0032.1020
03.0132.3020

Essgabel
Table fork
Fourchette de table
206 mm · 8¹/₁₆ in.



01.0032.1910
03.0132.3910

Essgabel³⁾
Table fork
Fourchette de table
203 mm · 8 in.



01.0032.1710
03.0132.3710

Menüegabel
Table fork
Fourchette de table
195 mm · 7¹/₁₆ in.



01.0032.1030
03.0132.3030

Tafelmesser¹⁾
Table knife
Couteau de table
245 mm · 9³/₄ in.



01.0032.1800
03.0132.3800

Tafelmesser
Table knife
Couteau de table
240 mm · 9⁷/₁₆ in.



01.0032.1050
03.0132.3050

Dessertlöffel
Dessert spoon
Cuiller à dessert
190 mm · 7⁵/₁₆ in.



01.0032.1060
03.0132.3060

Dessertgabel
Dessert fork
Fourchette à dessert
182 mm · 7³/₁₆ in.



01.0032.1920
03.0132.3920

Dessertgabel³⁾
Dessert fork
Fourchette à dessert
185 mm · 7⁹/₁₆ in.



01.0032.1070
03.0132.3070

Dessertmesser¹⁾
Dessert knife
Couteau à dessert
211 mm · 8⁵/₁₆ in.



01.0032.1810
03.0132.3810

Dessertmesser
Dessert knife
Couteau à dessert
212 mm · 8⁵/₁₆ in.



01.0032.1100
03.0132.3100

Kaffeelöffel
Coffee spoon
Cuiller à café
135 mm · 5⁵/₁₆ in.



01.0032.1110
03.0132.3110

Moccalöffel
Demi-tasse spoon
Cuiller à moka
111 mm · 4³/₁₆ in.



01.0032.1120
03.0132.3120

Kuchengabel
Cake fork
Fourchette à gâteau
155 mm · 6¹/₁₆ in.



01.0032.1140
03.0132.3140

Fischmesser
Fish knife
Couteau à poisson
198 mm · 7¹³/₁₆ in.



01.0032.1150
03.0132.3150

Fischgabel
Fish fork
Fourchette à poisson
179 mm · 7¹/₁₆ in.



01.0032.1180
03.0132.3180

Consommelöffel
Bouillon spoon
Cuiller à bouillon
160 mm · 6⁵/₁₆ in.



01.0032.1210
03.0132.3210

Limonadenlöffel
Iced tea spoon
Cuiller à soda
203 mm · 8 in.



01.0032.1330
03.0132.3330

Buttermesser²⁾
Butter knife
Couteau à beurre
170 mm · 6¹¹/₁₆ in.



01.0032.1500
03.0132.3500

Tranchiermesser¹⁾
Carving knife
Couteau à découper
250 mm · 9¹³/₁₆ in.



01.0032.1510
03.0132.3510

Tranchiergabel¹⁾
Carving fork
Fourchette à découper
225 mm · 8⁷/₁₆ in.



01.0032.1550
03.0132.3550

Steakmesser¹⁾
Steak knife
Couteau à steak
230 mm · 9¹/₁₆ in.



01.0032.1580
03.0132.3580

Franz. Saucenlöffel
French sauce spoon
Cuiller à sauce française
181 mm · 7¹/₁₆ in.



01.0032.1630
03.0132.3630

Runder Suppenlöffel
Round soup spoon
Cuiller rond à bouillon
180 mm · 7¹/₁₆ in.



01.0032.1720
03.0132.3720

Menümesser¹⁾
Table knife
Couteau de table
222 mm · 8³/₄ in.



01.0032.1820
03.0132.3820

Menümesser
Table knife
Couteau de table
223 mm · 8³/₄ in.



01.0032.1830
03.0132.3830

Tafelmesser²⁾
Table knife
Couteau de table
240 mm · 9⁷/₁₆ in.



01.0032.1850
03.0132.3850

Dessertmesser²⁾
Dessert knife
Couteau à dessert
212 mm · 8⁵/₁₆ in.



01.0032.1860
03.0132.3860

Buttermesser
Butter knife
Couteau à beurre
165 mm · 6¹/₂ in.

Besteck-Einzelteile
Serving pieces
pièces à servir

18/10
18/10
18/10

versilbert
silver plated
argenté

01.0032.1XX0

03.0132.3XX0

¹⁾ Hohlheft (18/10)
hollow handle (18/10)
orfèvre (18/10)

²⁾ ohne Wellenschliff
without serrated blade
sans lame crantée

³⁾ Designvariante
alternative design
variante de design





56.0401.6040
56.0401.6030
56.0401.6540

Menüöffel
Table spoon
Cuiller de table
217 mm · 8⁵/₁₆ in.



56.0402.6040
56.0402.6030
56.0402.6540

Menügabel
Table fork
Fourchette de table
215 mm · 8¹/₁₆ in.



56.0403.6049
56.0403.6039

Menümesser
Table knife
Couteau de table
236 mm · 9³/₁₆ in.



56.0404.6040
56.0404.6030
56.0404.6540

Vorspeisenlöffel
Dessert spoon
Cuiller à dessert
199 mm · 7¹³/₁₆ in.



56.0405.6040
56.0405.6030
56.0405.6540

Vorspeisengabel
Dessert fork
Fourchette à dessert
197 mm · 7³/₄ in.



56.0406.6049
56.0406.6039

Vorspeisenmesser
Dessert knife
Couteau à dessert
221 mm · 8¹¹/₁₆ in.



56.0407.6040
56.0407.6030
56.0407.6540

Kaffeelöffel
Coffee spoon
Cuiller à café
132 mm · 5³/₁₆ in.



56.0409.6040
56.0409.6030
56.0409.6540

Moccalöffel
Demi-tasse spoon
Cuiller à moka
108 mm · 4¹/₄ in.



56.0410.6040
56.0410.6030

**Vorspeisen-/
Dessertlöffel**
Dessert spoon
Cuiller à dessert
156 mm · 6¹/₈ in.



56.0435.6040
56.0435.6030

Fischgabel
Fish fork
Fourchette à poisson
184 mm · 7¹/₄ in.



56.0436.6040
56.0436.6030

Fischmesser
Fish knife
Couteau à poisson
206 mm · 8¹/₈ in.



56.0464.6040
56.0464.6030
56.0404.6540

Kuchengabel 3-zinkig
Cake fork
Fourchette à gâteau
157 mm · 6³/₁₆ in.



56.0466.6049
56.0466.6039

Buttermesser²⁾
Butter knife
Couteau à beurre
170 mm · 6¹¹/₁₆ in.



56.0472.6040
56.0472.6030
56.0472.6540

Limonadenlöffel
Iced tea spoon
Cuiller à soda
220 mm · 8¹¹/₁₆ in.



56.0475.6040
56.0475.6030

**Vorspeisen-/
Dessertgabel 4-zinkig**
Dessert fork
Fourchette à dessert
157 mm · 8³/₁₆ in.



56.0486.6049
56.0486.6039

Obstmesser
Fruit knife
Couteau à fruits
175 mm · 6⁷/₈ in.



56.0489.6040
56.0489.6030

Tassenlöffel
Round soup spoon
Cuiller à bouillon
166 mm · 6⁵/₁₆ in.

Besteck-Einzelteile
Serving pieces
pièces à servir

18/10
18/10
18/10

56.04XX.604X

versilbert
silver plated
argenté

56.04XX.603X

rostfreier Stahl
stainless steel
acier inoxydable

56.04XX.654X

¹⁾ Hohlheft (18/10)
hollow handle (18/10)
orfèvre (18/10)

²⁾ ohne Wellenschliff
without serrated blade
sans lame crantée

³⁾ Designvariante
alternative design
variante de design



HPP PREMIUM



01.0036.1010
03.0136.3010

Esslöffel
Table spoon
Cuiller de table
202 mm · 7¹⁵/₁₆ in.



01.0036.1020
03.0136.3020

Essgabel
Table fork
Fourchette de table
205 mm · 8¹/₁₆ in.



01.0036.1030
03.0136.3030

Tafelmesser¹⁾
Table knife
Couteau de table
226 mm · 8⁷/₈ in.



01.0036.1800
03.0136.3800

Tafelmesser
Table knife
Couteau de table
226 mm · 8⁷/₈ in.



01.0036.1830
03.0136.3830

Tafelmesser²⁾
Table knife
Couteau de table
226 mm · 8⁷/₈ in.



01.0036.1050
03.0136.3050

Dessertlöffel
Dessert spoon
Cuiller à dessert
177 mm · 6¹⁵/₁₆ in.



01.0036.1060
03.0136.3060

Dessertgabel
Dessert fork
Fourchette à dessert
178 mm · 7 in.



01.0036.1070
03.0136.3070

Dessertmesser¹⁾
Dessert knife
Couteau à dessert
206 mm · 8¹/₁₆ in.



01.0036.1810
03.0136.3810

Dessertmesser
Dessert knife
Couteau à dessert
206 mm · 8¹/₁₆ in.



01.0036.1850
03.0136.3850

Dessertmesser²⁾
Dessert knife
Couteau à dessert
206 mm · 8¹/₁₆ in.



01.0036.1100
03.0136.3100

Kaffeeelöffel
Coffee spoon
Cuiller à café
138 mm · 5⁷/₁₆ in.



01.0036.1110
03.0136.3110

Moccaelöffel
Demi-tasse spoon
Cuiller à moka
118 mm · 4⁹/₈ in.



01.0036.1130
03.0136.3130

Kuchengabel
Cake fork
Fourchette à gâteau
153 mm · 6 in.



01.0036.1140
03.0136.3140

Fischmesser
Fish knife
Couteau à poisson
214 mm · 8⁷/₁₆ in.



01.0036.1150
03.0136.3150

Fischgabel
Fish fork
Fourchette à poisson
175 mm · 6⁷/₈ in.



01.0036.1210
03.0136.3210

Limonadenlöffel
Iced tea spoon
Cuiller à soda
181 mm · 7¹/₈ in.



01.0036.1330
03.0136.3330

Buttermesser²⁾
Butter knife
Couteau à beurre
170 mm · 6¹/₁₆ in.



01.0036.1860
03.0136.3860

Buttermesser
Butter knife
Couteau à beurre
165 mm · 6¹/₂ in.



01.0036.1550
03.0136.3550

Steakmesser¹⁾
Steak knife
Couteau à steak
230 mm · 9¹/₁₆ in.



01.0036.1580
03.0136.3580

Franz. Saucenlöffel
French sauce spoon
Cuiller à sauce française
185 mm · 7⁵/₈ in.



01.0036.1630
03.0136.3630

Runder Suppenlöffel
Round soup spoon
Cuiller rond à bouillon
172 mm · 6³/₄ in.

Besteck-Einzelteile
Serving pieces
pièces à servir

18/10
18/10
18/10

versilbert
silver plated
argenté

rostfreier Stahl
stainless steel
acier inoxydable

rostfreier Stahl versilbert
stainless steel silver plated
acier inoxydable argenté

01.0036.1XX0

03.0136.3XX0

06.0036.1XX0

08.0136.3XX0

¹⁾ Hohlheft (18/10)
hollow handle (18/10)
orfèvre (18/10)

²⁾ ohne Wellenschliff
without serrated blade
sans lame crantée

³⁾ Designvariante
alternative design
variante de design



CARLTON



CARLTON



01.0045.1010
03.0145.3010

Esslöffel
Table spoon
Cuiller de table
205 mm · 8¹/₁₆ in.



01.0045.1020
03.0145.3020

Essgabel
Table fork
Fourchette de table
201 mm · 7⁹/₁₆ in.



01.0045.1030
03.0145.3030

Tafelmesser¹⁾
Table knife
Couteau de table
237 mm · 9⁵/₁₆ in.



01.0045.1800
03.0145.3800

Tafelmesser
Table knife
Couteau de table
237 mm · 9⁵/₁₆ in.



01.0045.1050
03.0145.3050

Dessertlöffel
Dessert spoon
Cuiller à dessert
180 mm · 7¹/₁₆ in.



01.0045.1060
03.0145.3060

Dessertgabel
Dessert fork
Fourchette à dessert
180 mm · 7¹/₁₆ in.



01.0045.1070
03.0145.3070

Dessertmesser¹⁾
Dessert knife
Couteau à dessert
210 mm · 8¹/₄ in.



01.0045.1810
03.0145.3810

Dessertmesser
Dessert knife
Couteau à dessert
215 mm · 8⁷/₁₆ in.



01.0045.1100
03.0145.3100

Kaffeelöffel
Coffee spoon
Cuiller à café
140 mm · 5¹/₂ in.



01.0045.1110
03.0145.3110

Moccalöffel
Demi-tasse spoon
Cuiller à moka
110 mm · 4³/₁₆ in.



01.0045.1120
03.0145.3120

Kuchengabel
Cake fork
Fourchette à gâteau
155 mm · 6¹/₈ in.



01.0045.1140
03.0145.3140

Fischmesser
Fish knife
Couteau à poisson
200 mm · 7⁷/₈ in.



01.0045.1150
03.0145.3150

Fischgabel
Fish fork
Fourchette à poisson
175 mm · 6⁷/₈ in.



01.0045.1190
03.0145.3190

Eisschaufel
Ice shovel
Cuiller à glace
131 mm · 5⁹/₁₆ in.



01.0045.1210
03.0145.3210

Limonadenlöffel
Iced tea spoon
Cuiller à soda
190 mm · 7¹/₂ in.



01.0045.1220
03.0145.3220

Austerngabel
Oyster fork
Fourchette à huîtres
130 mm · 5¹/₈ in.



01.0045.1260
03.0145.3260

Schnecken-gabel
Snail fork
Fourchette à escargots
145 mm · 5¹¹/₁₆ in.



01.0045.1300
03.0145.3300

Dressinglöffel
Dressing spoon
Cuiller à dressing
270 mm · 10⁹/₁₆ in.



01.0045.1330
03.0145.3330

Buttermesser²⁾
Butter knife
Couteau à beurre
170 mm · 6¹¹/₁₆ in.



01.0045.1340
03.0145.3340

Gemüselöffel
Vegetable spoon
Cuiller à légumes
203 mm · 8 in.



01.0045.1370
03.0145.3370

Saucenlöffel
Sauce spoon
Cuiller à sauce
180 mm · 7¹/₁₆ in.



01.0045.1400
03.0145.3400

Suppenshöpfer
Soup ladle, large
Louche grande
263 mm · 10³/₈ in.



01.0045.1410
03.0145.3410

Portionsschöpfer
Soup ladle, small
Louche petite
206 mm · 8¹/₈ in.



01.0045.1420
03.0145.3420

Tortenheber
Cake server
Pelle à tarte
225 mm · 8⁷/₈ in.



01.0045.1450
03.0145.3450

Vorlegegabel
Serving fork
Fourchette à servir
193 mm · 7⁵/₈ in.



01.0045.1470
03.0145.3470

Vorlegelöffel
Serving spoon
Cuiller à servir
270 mm · 10⁹/₁₆ in.



01.0045.1480
03.0145.3480

Vorlegegabel
Serving fork
Fourchette à servir
270 mm · 10⁹/₁₆ in.



01.0045.1540
03.0145.3540

Grapefruitlöffel
Grapefruit spoon
Cuiller à pamplemousse
146 mm · 5³/₄ in.



01.0045.1550
03.0145.3550

Steakmesser¹⁾
Steak knife
Couteau à steak
230 mm · 9¹/₁₆ in.



01.0045.1950
03.0145.3950

Steakmesser
Steak knife
Couteau à steak
230 mm · 9¹/₁₆ in.



01.0045.1560
03.0145.3560

Servierlöffel
Serving spoon
Cuiller à servir
228 mm · 9 in.



01.0045.1570
03.0145.3570

Serviergabel
Serving fork
Fourchette à servir
227 mm · 8¹⁵/₁₆ in.



01.0045.1580
03.0145.3580

Franz. Saucenlöffel
French sauce spoon
Cuiller à sauce française
185 mm · 7⁵/₁₆ in.



01.0045.1630
03.0145.3630

Runder Suppenlöffel
Round soup spoon
Cuiller rond à bouillon
175 mm · 6⁷/₈ in.

Besteck-Einzelteile
Serving pieces
pièces à servir

18/10
18/10
18/10

versilbert
silver plated
argenté

01.0045.1XX0

03.0145.3XX0

¹⁾ Hohlheft (18/10)
hollow handle (18/10)
orfèvre (18/10)

²⁾ ohne Wellenschliff
without serrated blade
sans lame crantée

³⁾ Designvariante
alternative design
variante de design





01.0050.1010
03.0150.3010

Esslöffel
Table spoon
Cuiller de table
211 mm · 8³/₁₆ in.



01.0050.1020
03.0150.3020

Essgabel
Table fork
Fourchette de table
210 mm · 8¹/₄ in.



01.0050.1800
03.0150.3800

Tafelmesser
Table knife
Couteau de table
239 mm · 9⁷/₁₆ in.



01.0050.1980
03.0150.3980

Tafelmesser³⁾
Table knife
Couteau de table
240 mm · 9⁷/₁₆ in.



01.0050.1050
03.0150.3050

Dessertlöffel
Dessert spoon
Cuiller à dessert
186 mm · 7⁵/₁₆ in.



01.0050.1060
03.0150.3060

Dessertgabel
Dessert fork
Fourchette à dessert
183 mm · 7³/₁₆ in.



01.0050.1810
03.0150.3810

Dessertmesser
Dessert knife
Couteau à dessert
201 mm · 7¹⁵/₁₆ in.



01.0050.1990
03.0150.3990

Dessertmesser³⁾
Dessert knife
Couteau à dessert
201 mm · 7¹⁵/₁₆ in.



01.0050.1100
03.0150.3100

Kaffeelöffel
Coffee spoon
Cuiller à café
142 mm · 5⁹/₁₆ in.



01.0050.1110
03.0150.3110

Moccalöffel
Demi-tasse spoon
Cuiller à moka
114 mm · 4¹/₂ in.



01.0050.1750
03.0150.3750

Nachspeisengabel
Dessert fork
Fourchette à dessert
151 mm · 5⁹/₁₆ in.



01.0050.1140
03.0150.3140

Fischmesser
Fish knife
Couteau à poisson
204 mm · 8¹/₁₆ in.



01.0050.1150
03.0150.3150

Fischgabel
Fish fork
Fourchette à poisson
180 mm · 7¹/₁₆ in.



01.0050.1210
03.0150.3210

Limonadenlöffel
Iced tea spoon
Cuiller à soda
191 mm · 7¹/₂ in.



01.0050.1330
03.0150.3330

Buttermesser²⁾
Butter knife
Couteau à beurre
170 mm · 6¹¹/₁₆ in.



01.0050.1890
03.0150.3890

Buttermesser²⁾³⁾
Butter knife
Couteau à beurre
170 mm · 6¹¹/₁₆ in.



01.0050.1580
03.0150.3580

Franz. Saucenlöffel
French sauce spoon
Cuiller à sauce française
185 mm · 7⁵/₁₆ in.



01.0050.1630
03.0150.3630

Runder Suppenlöffel
Round soup spoon
Cuiller rond à bouillon
180 mm · 7¹/₁₆ in.



01.0050.1950
03.0150.3950

Steakmesser
Steak knife
Couteau à steak
223 mm · 9⁷/₁₆ in.



01.0050.1970
03.0150.3970

Steakmesser³⁾
Steak knife
Couteau à steak
239 mm · 9⁷/₁₆ in.

Besteck-Einzelteile
Serving pieces
pièces à servir

18/10
18/10
18/10

versilbert
silver plated
argenté

01.0050.1XX0

03.0150.3XX0

¹⁾ Hohlheft (18/10)
hollow handle (18/10)
orfèvre (18/10)

²⁾ ohne Wellenschliff
without serrated blade
sans lame crantée

³⁾ Designvariante
alternative design
variante de design





01.0049.1010
03.0149.3010

Esslöffel
Table spoon
Cuiller de table
207 mm · 8¹/₈ in.



01.0049.1020
03.0149.3020

Essgabel
Table fork
Fourchette de table
208 mm · 8³/₁₆ in.



01.0049.1800
03.0149.3800

Tafelmesser
Table knife
Couteau de table
237 mm · 9⁵/₁₆ in.



01.0049.1050
03.0149.3050

Dessertlöffel
Dessert spoon
Cuiller à dessert
182 mm · 7³/₁₆ in.



01.0049.1060
03.0149.3060

Dessertgabel
Dessert fork
Fourchette à dessert
180 mm · 7¹/₁₆ in.



01.0049.1810
03.0149.3810

Dessertmesser
Dessert knife
Couteau à dessert
206 mm · 8³/₁₆ in.



01.0049.1090
03.0149.3090

Kaffeelöffel
Coffee spoon
Cuiller à café
148 mm · 5¹³/₁₆ in.



01.0049.1110
03.0149.3110

Moccalöffel
Demi-tasse spoon
Cuiller à moka
115 mm · 4¹/₂ in.



01.0049.1750
03.0149.3750

Nachspeisengabel
Dessert fork
Fourchette à dessert
153 mm · 6 in.



01.0049.1140
03.0149.3140

Fischmesser
Fish knife
Couteau à poisson
203 mm · 8 in.



01.0049.1150
03.0149.3150

Fischgabel
Fish fork
Fourchette à poisson
178 mm · 7 in.



01.0049.1210
03.0149.3210

Limonadenlöffel
Iced tea spoon
Cuiller à soda
192 mm · 7⁹/₁₆ in.



01.0049.1330
03.0149.3330

Buttermesser²⁾
Butter knife
Couteau à beurre
170 mm · 6¹¹/₁₆ in.



01.0049.1580
03.0149.3580

Franz. Saucenlöffel
French sauce spoon
Cuiller à sauce française
182 mm · 7³/₁₆ in.



01.0049.1630
03.0149.3630

Runder Suppenlöffel
Round soup spoon
Cuiller rond à bouillon
178 mm · 7 in.



01.0049.1950
03.0149.3950

Steakmesser
Steak knife
Couteau à steak
234 mm · 9³/₁₆ in.

Besteck-Einzelteile
Serving pieces
pièces à servir

18/10
18/10
18/10

versilbert
silver plated
argenté

01.0049.1XX0

03.0149.3XX0

¹⁾ Hohlheft (18/10)
hollow handle (18/10)
orfèvre (18/10)

²⁾ ohne Wellenschliff
without serrated blade
sans lame crantée

³⁾ Designvariante
alternative design
variante de design





56.0901.6040
56.0901.6030

Menüöffel
Table spoon
Cuiller de table
217 mm · 8½ in.



56.0902.6040
56.0902.6030

Menügabel
Table fork
Fourchette de table
215 mm · 8½ in.



56.0903.6049
56.0903.6039

Menümesser
Table knife
Couteau de table
236 mm · 9¼ in.



56.0904.6040
56.0904.6030

Vorspeisenlöffel
Dessert spoon
Cuiller à dessert
199 mm · 7¾ in.



56.0905.6040
56.0905.6030

Vorspeisengabel
Dessert fork
Fourchette à dessert
197 mm · 7¾ in.



56.0906.6049
56.0906.6039

Vorspeisenmesser
Dessert knife
Couteau à dessert
221 mm · 8¾ in.



56.0907.6040
56.0907.6030

Kaffeelöffel
Coffee spoon
Cuiller à café
137 mm · 5½ in.



56.0909.6040
56.0909.6030

Mokkalöffel
Demi-tasse spoon
Cuiller à moka
110 mm · 4¼ in.



56.0910.6040
56.0910.6030

Dessertlöffel
Dessert spoon
Cuiller à dessert
159 mm · 6¼ in.



56.0935.6040
56.0935.6030

Fischgabel
Fish fork
Fourchette à poisson
195 mm · 7¾ in.



56.0936.6040
56.0936.6030

Fischmesser
Fish knife
Couteau à poisson
215 mm · 8½ in.



56.0964.6040
56.0964.6030

Kuchengabel 3-zinkig
Cake fork
Fourchette à gâteau
158 mm · 6¼ in.



56.0966.6049
56.0966.6039

Buttermesser²⁾
Butter knife
Couteau à beurre
170 mm · 6¾ in.



56.0972.6040
56.0972.6030

Limonadenlöffel
Iced tea spoon
Cuiller à soda
220 mm · 8¾ in.



56.0975.6040
56.0975.6030

**Vorspeisen-/
Dessertgabel 4-zinkig**
Dessert fork
Fourchette à dessert
158 mm · 6¼ in.



56.0986.6049
56.0986.6039

Obstmesser
Fruit knife
Couteau à fruits
180 mm · 7 in.



56.0989.6040
56.0989.6030

Tassenlöffel
Round soup spoon
Cuiller à bouillon
170 mm · 6¾ in.

Besteck-Einzelteile
Serving pieces
pièces à servir

18/10
18/10
18/10

56.09XX.604X

versilbert
silver plated
argenté

56.09XX.603X

¹⁾ Hohlheft (18/10)
hollow handle (18/10)
orfèvre (18/10)

²⁾ ohne Wellenschliff
without serrated blade
sans lame crantée

³⁾ Designvariante
alternative design
variante de design





01.0013.1010
03.0113.3010

Esslöffel
Table spoon
Cuiller de table
209 mm · 8¼ in.



01.0013.1020
03.0113.3020

Essgabel
Table fork
Fourchette de table
209 mm · 8¼ in.



01.0013.1600
03.0113.3600

Tafelmesser¹⁾
Table knife
Couteau de table
248 mm · 9¾ in.



01.0013.1800
03.0113.3800

Tafelmesser
Table knife
Couteau de table
248 mm · 9¾ in.



01.0013.1050
03.0113.3050

Dessertlöffel
Dessert spoon
Cuiller à dessert
178 mm · 7 in.



01.0013.1060
03.0113.3060

Dessertgabel
Dessert fork
Fourchette à dessert
180 mm · 7⅛ in.



01.0013.1610
03.0113.3610

Dessertmesser¹⁾
Dessert knife
Couteau à dessert
213 mm · 8⅜ in.



01.0013.1810
03.0113.3810

Dessertmesser
Dessert knife
Couteau à dessert
213 mm · 8⅜ in.



01.0013.1090
03.0113.3090

Kaffeeöffel
Coffee spoon
Cuiller à café
142 mm · 5⅝ in.



01.0013.1110
03.0113.3110

Moccalöffel
Demi-Tasse spoon
Cuiller à moka
109 mm · 4⅞ in.



01.0013.1120
03.0113.3120

Kuchengabel
Cake fork
Fourchette à gâteau
159 mm · 6¼ in.



01.0013.1750
03.0113.3750

Nachspeisengabel
Dessert fork
Fourchette à dessert
140 mm · 5½ in.



01.0013.1140
03.0113.3140

Fischmesser
Fish knife
Couteau à poisson
203 mm · 8 in.



01.0013.1150
03.0113.3150

Fischgabel
Fish fork
Fourchette à poisson
180 mm · 7⅛ in.



01.0013.1160
03.0113.3160

Obstmesser¹⁾
Fruit knife
Couteau à fruits
165 mm · 6½ in.



01.0013.1180
03.0113.3180

Consommelöffel
Boillon spoon
Cuiller à bouillon
150 mm · 5⅞ in.



01.0013.1210
03.0113.3210

Limonadenlöffel
Iced tea spoon
Cuiller à soda
190 mm · 7½ in.



01.0013.1330
03.0113.3330

Buttermesser²⁾
Butter knife
Couteau à beurre
170 mm · 6⅞ in.



01.0013.1550
03.0113.3550

Steakmesser¹⁾
Steak knife
Couteau à steak
234 mm · 9⅞ in.



01.0013.1580
03.0113.3580

Franz. Saucenlöffel
French sauce spoon
Cuiller à sauce française
181 mm · 7⅞ in.



01.0013.1630
03.0113.3630

Runder Suppenlöffel
Round soup spoon
Cuiller rond à bouillon
180 mm · 7⅛ in.

Besteck-Einzelteile
Serving pieces
pièces à servir

18/10
18/10
18/10

01.0013.1XX0

versilbert
silver plated
argenté

03.0113.3XX0

¹⁾ Hohlheft (18/10)
hollow handle (18/10)
orfèvre (18/10)

²⁾ ohne Wellenschliff
without serrated blade
sans lame crantée

³⁾ Designvariante
alternative design
variante de design



REF. EXCLUSIF



56.0601.6040
56.0601.6030

Menüöffel
Table spoon
Cuiller de table
230 mm · 9¹/₁₆ in.



56.0602.6040
56.0602.6030

Menügabel
Table fork
Fourchette de table
228 mm · 9 in.



56.0603.6049
56.0603.6039

Menümesser
Table knife
Couteau de table
246 mm · 9¹¹/₁₆ in.



56.0604.6040
56.0604.6030

Vorspeisenöffel
Dessert spoon
Cuiller à dessert
206 mm · 8¹/₈ in.



56.0605.6040
56.0605.6030

Vorspeisengabel
Dessert fork
Fourchette à dessert
204 mm · 8¹/₈ in.



56.0606.6049
56.0606.6039

Vorspeisenmesser
Dessert knife
Couteau à dessert
220 mm · 8¹¹/₁₆ in.



56.0607.6040
56.0607.6030

Kaffeeöffel
Coffee spoon
Cuiller à café
157 mm · 6³/₁₆ in.



56.0609.6040
56.0609.6030

Moccalöffel
Demi-tasse spoon
Cuiller à moka
110 mm · 4⁵/₁₆ in.



56.0611.6040
56.0611.6030

Franz. Saucenöffel
French sauce spoon
Cuiller à sauce français
209 mm · 8¹/₄ in.



56.0635.6040
56.0635.6030

Fischgabel
Fish fork
Fourchette à poisson
214 mm · 8⁷/₁₆ in.



56.0636.6040
56.0636.6030

Fischmesser
Fish knife
Couteau à poisson
231 mm · 9¹/₈ in.



56.0666.6049
56.0666.6039

Buttermesser²⁾
Butter knife
Couteau à beurre
185 mm · 7⁹/₁₆ in.



56.0672.6040
56.0672.6030

Limonadenöffel
Iced tea spoon
Cuiller à soda
220 mm · 8¹¹/₁₆ in.



56.0675.6040
56.0675.6030

**Vorspeisen-/
Dessertgabel 4-zinkig**
Dessert fork
Fourchette à dessert
172 mm · 6³/₄ in.



56.0678.6049
56.0678.6039

Steakmesser
Steak knife
Couteau à steak
249 mm · 9¹³/₁₆ in.



56.0689.6040
56.0689.6030

Tassenöffel
Round soup spoon
Cuiller à bouillon
190 mm · 7¹/₂ in.

Besteck-Einzelteile
Serving pieces
pièces à servir

18/10
18/10
18/10

versilbert
silver plated
argenté

56.06XX.604X

56.06XX.603X

¹⁾ Hohlheft (18/10)
hollow handle (18/10)
orfèvre (18/10)

²⁾ ohne Wellenschliff
without serrated blade
sans lame crantée

³⁾ Designvariante
alternative design
variante de design





56.2301.6040
56.2301.6030

Menüöffel
Table spoon
Cuiller de table
214 mm · 8⁷/₁₆ in.



56.2302.6040
56.2302.6030

Menügabel
Table fork
Fourchette de table
212 mm · 8⁵/₈ in.



56.2303.6049
56.2303.6039

Menümesser
Table knife
Couteau de table
235 mm · 9¹/₄ in.



56.2304.6040
56.2304.6030

Vorspeisenlöffel
Dessert spoon
Cuiller à dessert
196 mm · 7¹¹/₁₆ in.



56.2305.6040
56.2305.6030

Vorspeisengabel
Dessert fork
Fourchette à dessert
194 mm · 7⁷/₈ in.



56.2306.6049
56.2306.6039

Vorspeisenmesser
Dessert knife
Couteau à dessert
215 mm · 8⁷/₁₆ in.



56.2307.6040
56.2307.6030

Kaffeelöffel
Coffee spoon
Cuiller à café
134 mm · 5¹/₄ in.



56.2309.6040
56.2309.6030

Moccalöffel
Demi-tasse spoon
Cuiller à moka
110 mm · 4⁵/₁₆ in.



56.2310.6040
56.2310.6030

**Vorspeisen-/
Dessertlöffel**
Dessert spoon
Cuiller à dessert
159 mm · 6¹/₄ in.



56.2311.6040
56.2311.6030

Franz. Saucenlöffel
French sauce spoon
Cuiller à sauce français
197 mm · 7⁷/₄ in.



56.2335.6040
56.2335.6030

Fischgabel
Fish fork
Fourchette à poisson
190 mm · 7¹/₂ in.



56.2336.6040
56.2336.6030

Fischmesser
Fish knife
Couteau à poisson
214 mm · 8⁷/₁₆ in.



56.2366.6049
56.2366.6039

Buttermesser²⁾
Butter knife
Couteau à beurre
170 mm · 6¹¹/₁₆ in.



56.2372.6040
56.2372.6030

Limonadenlöffel
Iced tea spoon
Cuiller à soda
220 mm · 8¹¹/₁₆ in.



56.2375.6040
56.2375.6030

**Vorspeisen-/
Dessertgabel 4-zinkig**
Dessert fork
Fourchette à dessert
159 mm · 6¹/₄ in.



56.2378.6049
56.2378.6039

Steakmesser
Steak knife
Couteau à steak
235 mm · 9¹/₄ in.



56.2389.6040
56.2389.6030

Tassenlöffel
Round soup spoon
Cuiller à bouillon
170 mm · 6¹¹/₁₆ in.

Besteck-Einzelteile
Serving pieces
pièces à servir

18/10
18/10
18/10

versilbert
silver plated
argenté

56.23XX.604X

56.23XX.603X

¹⁾ Hohlheft (18/10)
hollow handle (18/10)
orfèvre (18/10)

²⁾ ohne Wellenschliff
without serrated blade
sans lame crantée

³⁾ Designvariante
alternative design
variante de design



HEPP 5122-001



56.4401.6040
56.4401.6030

Menüöffel
Table spoon
Cuiller de table
214 mm · 8½ in.



56.4402.6040
56.4402.6030

Menügabel
Table fork
Fourchette de table
212 mm · 8¼ in.



56.4403.6047
56.4403.6037

Menümesser¹⁾³⁾
Table knife
Couteau de table
232 mm · 9¼ in.



56.4403.6049
56.4403.6039

Menümesser
Table knife
Couteau de table
237 mm · 9¼ in.



56.4404.6040
56.4404.6030

Vorspeisenöffel
Dessert spoon
Cuiller à dessert
196 mm · 7¾ in.



56.4405.6040
56.4405.6030

Vorspeisengabel
Dessert fork
Fourchette à dessert
194 mm · 7¾ in.



56.4406.6047
56.4406.6037

Vorspeisenmesser¹⁾³⁾
Dessert knife
Couteau à dessert
207 mm · 8¼ in.



56.4406.6049
56.4406.6039

Vorspeisenmesser
Dessert knife
Couteau à dessert
217 mm · 8½ in.



56.4407.6040
56.4407.6030

Kaffeeöffel
Coffee spoon
Cuiller à café
136 mm · 5¼ in.



56.4409.6040
56.4409.6030

Mokkalöffel
Demi-tasse spoon
Cuiller à moka
108 mm · 4¼ in.



56.4410.6040
56.4410.6030

Dessertöffel
Dessert spoon
Cuiller à dessert
156 mm · 6⅝ in.



56.4411.6040
56.4411.6030

Franz. Saucenlöffel
French sauce spoon
Cuiller à sauce française
196 mm · 7¾ in.



56.4435.6040
56.4435.6030

Fischgabel
Fish fork
Fourchette à poisson
190 mm · 7½ in.



56.4436.6040
56.4436.6030

Fischmesser
Fish knife
Couteau à poisson
212 mm · 8¼ in.



56.4466.6049
56.4466.6039

Buttermesser²⁾
Butter knife
Couteau à beurre
170 mm · 6¾ in.



56.4472.6040
56.4472.6030

Limonadenlöffel
Iced tea spoon
Cuiller à soda
220 mm · 8¾ in.



56.4475.6040
56.4475.6030

**Vorspeisen-/
Dessertgabel 4-zinkig**
Dessert fork
Fourchette à dessert
159 mm · 6¼ in.



56.4478.6049
56.4478.6039

Steakmesser
Steak knife
Couteau à steak
239 mm · 9½ in.



56.4489.6040
56.4489.6030

Tassenlöffel
Round soup spoon
Cuiller à bouillon
170 mm · 6¾ in.

Besteck-Einzelteile
Serving pieces
pièces à servir

18/10
18/10
18/10

versilbert
silver plated
argenté

56.44XX.604X

56.44XX.603X

¹⁾ Hohlheft (18/10)
hollow handle (18/10)
orfèvre (18/10)

²⁾ ohne Wellenschliff
without serrated blade
sans lame crantée

³⁾ Designvariante
alternative design
variante de design





01.0042.1010
03.0142.3010

Esslöffel
Table spoon
Cuiller de table
205 mm · 8¹/₁₆ in.



01.0042.1020
03.0142.3020

Essgabel
Table fork
Fourchette de table
205 mm · 8¹/₁₆ in.



01.0042.1030
03.0142.3030

Tafelmesser¹⁾
Table knife
Couteau de table
228 mm · 9 in.



01.0042.1800
03.0142.3800

Tafelmesser
Table knife
Couteau de table
228 mm · 9 in.



01.0042.1830
03.0142.3830

Tafelmesser³⁾
Table knife
Couteau de table
228 mm · 9 in.



01.0042.1050
03.0142.3050

Dessertlöffel
Dessert spoon
Cuiller à dessert
180 mm · 7¹/₁₆ in.



01.0042.1060
03.0142.3060

Dessertgabel
Dessert fork
Fourchette à dessert
180 mm · 7¹/₁₆ in.



01.0042.1070
03.0142.3070

Dessertmesser¹⁾
Dessert knife
Couteau à dessert
206 mm · 8¹/₁₆ in.



01.0042.1810
03.0142.3810

Dessertmesser
Dessert knife
Couteau à dessert
206 mm · 8¹/₁₆ in.



01.0042.1850
03.0142.3850

Dessertmesser²⁾
Dessert knife
Couteau à dessert
206 mm · 8¹/₁₆ in.



01.0042.1100
03.0142.3100

Kaffeelöffel
Coffee spoon
Cuiller à café
140 mm · 5¹/₂ in.



01.0042.1110
03.0142.3110

Moccalöffel
Demi-tasse spoon
Cuiller à moka
120 mm · 4³/₄ in.



01.0042.1120
03.0142.3120

Kuchengabel
Cake fork
Fourchette à gâteau
155 mm · 6¹/₈ in.



01.0042.1140
03.0142.3140

Fischmesser
Fish knife
Couteau à poisson
208 mm · 8¹/₁₆ in.



01.0042.1150
03.0142.3150

Fischgabel
Fish fork
Fourchette à poisson
191 mm · 7¹/₁₆ in.



01.0042.1210
03.0142.3210

Limonadenlöffel
Iced tea spoon
Cuiller à soda
185 mm · 7³/₁₆ in.



01.0042.1320
03.0142.3320

Buttermesser¹⁾
Butter knife
Couteau à beurre
170 mm · 6¹/₁₆ in.



01.0042.1330
03.0142.3330

Buttermesser²⁾
Butter knife
Couteau à beurre
170 mm · 6¹/₁₆ in.



01.0042.1950
03.0142.3950

Steakmesser
Steak knife
Couteau à steak
236 mm · 9³/₁₆ in.



01.0042.1580
03.0142.3580

Franz. Saucenlöffel
French sauce spoon
Cuiller à sauce française
185 mm · 7³/₁₆ in.



01.0042.1630
03.0142.3630

Runder Suppenlöffel
Round soup spoon
Cuiller rond à bouillon
175 mm · 6⁷/₁₆ in.

Besteck-Einzelteile
Serving pieces
pièces à servir

18/10
18/10
18/10

versilbert
silver plated
argenté

01.0042.1XX0

03.0142.3XX0

¹⁾ Hohlheft (18/10)
hollow handle (18/10)
orfèvre (18/10)

²⁾ ohne Wellenschliff
without serrated blade
sans lame crantée

³⁾ Designvariante
alternative design
variante de design





01.0053.1010
03.0153.3010

Esslöffel
Table spoon
Cuiller de table
203 mm · 8 in.



01.0053.1020
03.0153.3020

Essgabel
Table fork
Fourchette de table
202 mm · 7¹⁵/₁₆ in.



01.0053.1800
03.0153.3800

Tafelmesser
Table knife
Couteau de table
230 mm · 9¹/₁₆ in.



01.0053.1801
03.0153.3801

Tafelmesser³⁾
Table knife
Couteau de table
230 mm · 9¹/₁₆ in.



01.0053.1050
03.0153.3050

Dessertlöffel
Dessert spoon
Cuiller à dessert
180 mm · 7¹/₁₆ in.



01.0053.1060
03.0153.3060

Dessertgabel
Dessert fork
Fourchette à dessert
179 mm · 7¹/₁₆ in.



01.0053.1810
03.0153.3810

Dessertmesser
Dessert knife
Couteau à dessert
220 mm · 8¹¹/₁₆ in.



01.0053.1811
03.0153.3811

Dessertmesser³⁾
Dessert knife
Couteau à dessert
220 mm · 8¹¹/₁₆ in.



01.0053.1100
03.0153.3100

Kaffeelöffel
Coffee spoon
Cuiller à café
132 mm · 5⁹/₁₆ in.



01.0053.1110
03.0153.3110

Moccalöffel
Demi-tasse spoon
Cuiller à moka
110 mm · 4¹/₁₆ in.



01.0053.1750
03.0153.3750

Nachspeisengabel
Dessert fork
Fourchette à dessert
151 mm · 5⁹/₁₆ in.



01.0053.1140
03.0153.3140

Fischmesser
Fish knife
Couteau à poisson
204 mm · 8¹/₁₆ in.



01.0053.1150
03.0153.3150

Fischgabel
Fish fork
Fourchette à poisson
179 mm · 7¹/₁₆ in.



01.0053.1210
03.0153.3210

Limonadenlöffel
Iced tea spoon
Cuiller à soda
185 mm · 7³/₁₆ in.



01.0053.1330
03.0153.3330

Buttermesser²⁾
Butter knife
Couteau à beurre
170 mm · 6¹¹/₁₆ in.



01.0053.1580
03.0153.3580

Franz. Saucenlöffel
French sauce spoon
Cuiller à sauce française
183 mm · 7³/₁₆ in.



01.0053.1630
03.0153.3630

Runder Suppenlöffel
Round soup spoon
Cuiller à bouillon
176 mm · 6⁵/₁₆ in.



01.0053.1950
03.0153.3950

Steakmesser
Steak knife
Couteau à steak
230 mm · 9¹/₁₆ in.

Besteck-Einzelteile
Serving pieces
pièces à servir

18/10
18/10
18/10

versilbert
silver plated
argenté

01.0053.1XXX

03.0153.3XXX

¹⁾ Hohlheft (18/10)
hollow handle (18/10)
orfèvre (18/10)

²⁾ ohne Wellenschliff
without serrated blade
sans lame crantée

³⁾ Designvariante
alternative design
variante de design





01.0043.1010
03.0143.3010

Esslöffel
Table spoon
Cuiller de table
205 mm · 8¹/₁₆ in.



01.0043.1020
03.0143.3020

Essgabel
Table fork
Fourchette de table
208 mm · 8³/₁₆ in.



01.0043.1030
03.0143.3030

Tafelmesser¹⁾
Table knife
Couteau de table
237 mm · 9⁵/₁₆ in.



01.0043.1800
03.0143.3800

Tafelmesser
Table knife
Couteau de table
237 mm · 9⁵/₁₆ in.



01.0043.1050
03.0143.3050

Dessertlöffel
Dessert spoon
Cuiller à dessert
182 mm · 7³/₁₆ in.



01.0043.1060
03.0143.3060

Dessertgabel
Dessert fork
Fourchette à dessert
184 mm · 7¹/₄ in.



01.0043.1070
03.0143.3070

Dessertmesser¹⁾
Dessert knife
Couteau à dessert
211 mm · 8⁵/₁₆ in.



01.0043.1810
03.0143.3810

Dessertmesser
Dessert knife
Couteau à dessert
211 mm · 8⁵/₁₆ in.



01.0043.1100
03.0143.3100

Kaffeelöffel
Coffee spoon
Cuiller à café
140 mm · 5¹/₂ in.



01.0043.1110
03.0143.3110

Moccalöffel
Demi-tasse spoon
Cuiller à moka
109 mm · 4³/₁₆ in.



01.0043.1130
03.0143.3130

Kuchengabel
Cake fork
Fourchette à gâteau
155 mm · 6¹/₈ in.



01.0043.1140
03.0143.3140

Fischmesser
Fish knife
Couteau à poisson
204 mm · 8¹/₁₆ in.



01.0043.1150
03.0143.3150

Fischgabel
Fish fork
Fourchette à poisson
182 mm · 7³/₁₆ in.



01.0043.1210
03.0143.3210

Limonadenlöffel
Iced tea spoon
Cuiller à soda
191 mm · 7¹/₂ in.



01.0043.1320
03.0143.3320

Buttermesser¹⁾²⁾
Butter knife
Couteau à beurre
171 mm · 6³/₄ in.



01.0043.1330
03.0143.3330

Buttermesser²⁾
Butter knife
Couteau à beurre
171 mm · 6³/₄ in.



01.0043.1550
03.0143.3550

Steakmesser¹⁾
Steak knife
Couteau à steak
231 mm · 9¹/₈ in.



01.0043.1580
03.0143.3580

Franz. Saucenlöffel
French sauce spoon
Cuiller à sauce française
185 mm · 7⁵/₁₆ in.



01.0043.1630
03.0143.3630

Runder Suppenlöffel
Round soup spoon
Cuiller rond à bouillon
177 mm · 6⁹/₁₆ in.

Besteck-Einzelteile
Serving pieces
pièces à servir

18/10
18/10
18/10

versilbert
silver plated
argenté

01.0043.1XX0

03.0143.3XX0

¹⁾ Hohlheft (18/10)
hollow handle (18/10)
orfèvre (18/10)

²⁾ ohne Wellenschliff
without serrated blade
sans lame crantée

³⁾ Designvariante
alternative design
variante de design



HEPP EXCLUSIV



01.0054.1010
03.0154.3010

Esslöffel
Table spoon
Cuiller de table
212 mm · 8³/₈ in.



01.0054.1020
03.0154.3020

Essgabel
Table fork
Fourchette de table
210 mm · 8¹/₄ in.



01.0054.1800
03.0154.3800

Tafelmesser
Table knife
Couteau de table
234 mm · 9³/₁₆ in.



01.0054.1050
03.0154.3050

Dessertlöffel
Dessert spoon
Cuiller à dessert
190 mm · 7¹/₂ in.



01.0054.1060
03.0154.3060

Dessertgabel
Dessert fork
Fourchette à dessert
188 mm · 7³/₈ in.



01.0054.1810
03.0154.3810

Dessertmesser
Dessert knife
Couteau à dessert
210 mm · 8¹/₄ in.



01.0054.1100
03.0154.3100

Kaffeelöffel
Coffee spoon
Cuiller à café
136 mm · 5³/₈ in.



01.0054.1110
03.0154.3110

Moccalöffel
Demi-tasse spoon
Cuiller à moka
110 mm · 4⁵/₁₆ in.



01.0054.1140
03.0154.3140

Fischmesser
Fish knife
Couteau à poisson
208 mm · 8³/₁₆ in.



01.0054.1150
03.0154.3150

Fischgabel
Fish fork
Fourchette à poisson
184 mm · 7¹/₄ in.



01.0054.1210
03.0154.3210

Limonadenlöffel
Iced tea spoon
Cuiller à soda
220 mm · 8¹¹/₁₆ in.



01.0054.1330
03.0154.3330

Buttermesser²⁾
Butter knife
Couteau à beurre
170 mm · 6¹¹/₁₆ in.



01.0054.1580
03.0154.3580

Franz. Saucenlöffel
French sauce spoon
Cuiller à sauce française
195 mm · 7¹¹/₁₆ in.



01.0054.1630
03.0154.3630

Runder Suppenlöffel
Round soup spoon
Cuiller rond à bouillon
176 mm · 6¹⁵/₁₆ in.



01.0054.1750
03.0154.3750

Nachspeisengabel
Dessert fork
Fourchette à dessert
160 mm · 6³/₁₆ in.



01.0054.1950
03.0154.3950

Steakmesser
Steak knife
Couteau à steak
239 mm · 9¹/₁₆ in.

Besteck-Einzelteile
Serving pieces
pièces à servir

18/10
18/10
18/10

versilbert
silver plated
argenté

01.0054.1XX0

03.0154.3XX0

¹⁾ Hohlheft (18/10)
hollow handle (18/10)
orfèvre (18/10)

²⁾ ohne Wellenschliff
without serrated blade
sans lame crantée

³⁾ Designvariante
alternative design
variante de design





01.0025.1650
03.0125.3650

Esslöffel
Table spoon
Cuiller de table
203 mm · 8 in.



01.0025.1660
03.0125.3660

Essgabel
Table fork
Fourchette de table
203 mm · 8 in.



01.0025.1670
03.0125.3670

Tafelmesser¹⁾
Table knife
Couteau de table
238 mm · 9³/₈ in.



01.0025.1800
03.0125.3800

Tafelmesser
Table knife
Couteau de table
238 mm · 9³/₈ in.



01.0025.1870
03.0125.3870

Tafelmesser
Table knife
Couteau de table
238 mm · 9³/₈ in.



01.0025.1050
03.0125.3050

Dessertlöffel
Dessert spoon
Cuiller à dessert
180 mm · 7¹/₁₆ in.



01.0025.1060
03.0125.3060

Dessertgabel
Dessert fork
Fourchette à dessert
180 mm · 7¹/₁₆ in.



01.0025.1070
03.0125.3070

Dessertmesser¹⁾
Dessert knife
Couteau à dessert
209 mm · 8¹/₄ in.



01.0025.1810
03.0125.3810

Dessertmesser
Dessert knife
Couteau à dessert
209 mm · 8¹/₄ in.



01.0025.1850
03.0125.3850

Dessertmesser
Dessert knife
Couteau à dessert
209 mm · 8¹/₄ in.



01.0025.1100
03.0125.3100

Kaffeelöffel
Coffee spoon
Cuiller à café
133 mm · 5¹/₄ in.



01.0025.1110
03.0125.3110

Moccalöffel
Demi-tasse spoon
Cuiller à moka
115 mm · 4¹/₂ in.



01.0025.1750
03.0125.3750

Nachspeisengabel
Dessert fork
Fourchette à dessert
150 mm · 5⁷/₈ in.



01.0025.1140
03.0125.3140

Fischmesser
Fish knife
Couteau à poisson
203 mm · 8 in.



01.0025.1150
03.0125.3150

Fischgabel
Fish fork
Fourchette à poisson
173 mm · 6⁹/₁₆ in.



01.0025.1210
03.0125.3210

Limonadenlöffel
Iced tea spoon
Cuiller à soda
183 mm · 7³/₁₆ in.



01.0025.1220
03.0125.3220

Austergabel
Oyster fork
Fourchette à huîtres
133 mm · 5¹/₄ in.



01.0025.1330
03.0125.3330

Buttermesser²⁾
Butter knife
Couteau à beurre
163 mm · 6⁵/₁₆ in.



01.0025.1550
03.0125.3550

Steakmesser¹⁾
Steak knife
Couteau à steak
224 mm · 8⁹/₁₆ in.



01.0025.1580
03.0125.3580

Franz. Saucenlöffel
French sauce spoon
Cuiller à sauce française
186 mm · 7⁵/₁₆ in.



01.0025.1630
03.0125.3630

Runder Suppenlöffel
Round soup spoon
Cuiller rond à bouillon
176 mm · 6¹⁵/₁₆ in.



01.0025.1880
03.0125.3880

Obstmesser
Fruit knife
Couteau à fruits
157 mm · 6³/₁₆ in.

Besteck-Einzelteile
Serving pieces
pièces à servir

18/10
18/10
18/10

versilbert
silver plated
argenté

01.0025.1XX0

03.0125.3XX0

¹⁾ Hohlheft (18/10)
hollow handle (18/10)
orfèvre (18/10)

²⁾ ohne Wellenschliff
without serrated blade
sans lame crantée

³⁾ Designvariante
alternative design
variante de design



MEPP EXCLUSIV



06.0010.1700
06.0011.1700

Menüöffel
Table spoon
Cuiller de table
193 mm · 7⁵/₈ in.



06.0010.1710
06.0011.1710

Menügabel
Table fork
Fourchette de table
194 mm · 7⁵/₈ in.



06.0010.1840

Menümesser
Table knife
Couteau de table
207 mm · 8¹/₈ in.



06.0010.1050
06.0011.1050

Dessertlöffel
Dessert spoon
Cuiller à dessert
179 mm · 7¹/₁₆ in.



06.0010.1060
06.0011.1060

Dessertgabel
Dessert fork
Fourchette à dessert
180 mm · 7¹/₁₆ in.



06.0010.1850

Dessertmesser
Dessert knife
Couteau à dessert
196 mm · 7¹¹/₁₆ in.



06.0010.1100
06.0011.1100

Kaffeelöffel
Coffee spoon
Cuiller à café
135 mm · 5⁵/₁₆ in.



06.0010.1110
06.0011.1110

Moccalöffel
Demi-tasse spoon
Cuiller à moka
110 mm · 4⁵/₁₆ in.



06.0010.1210
06.0011.1210

Limonadenlöffel
Iced tea spoon
Cuiller à soda
209 mm · 8³/₄ in.



06.0010.1580

Franz. Saucenlöffel
French sauce spoon
Cuiller à sauce française
183 mm · 7³/₁₆ in.



06.0011.1630

Runder Suppenlöffel
Round soup spoon
Cuiller rond à bouillon
179 mm · 7¹/₁₆ in.



06.0010.1730

Fischmesser
Fish knife
Couteau à poisson
203 mm · 8 in.



06.0010.1740

Nachspeisenlöffel
Dessert spoon
Cuiller à dessert
155 mm · 6¹/₈ in.



06.0010.1750
06.0011.1750

Nachspeisengabel
Dessert fork
Fourchette à dessert
140 mm · 5¹/₂ in.



06.0010.1860

Buttermesser
Butter knife
Couteau à beurre
170 mm · 6¹¹/₁₆ in.



06.0010.1950

Steakmesser
Steak knife
Couteau à steak
220 mm · 8¹¹/₁₆ in.

Besteck-Einzelteile
Serving pieces
pièces à servir

rostfreier Stahl 18/10

stainless steel 18/10

acier inoxydable 18/10

06.0010.1XX0 06.0011.1XX0

¹⁾ Hohlheft (18/10)
hollow handle (18/10)
orfèvre (18/10)

²⁾ ohne Wellenschliff
without serrated blade
sans lame crantée

³⁾ Designvariante
alternative design
variante de design



HEPP PREMIUM



06.0047.1700

Menüöffel
Table spoon
Cueillir de table
197 mm · 7¾ in.



06.0047.1710

Menügabel
Table fork
Fourchette de table
193 mm · 7⅝ in.



06.0047.1840

Menümesser
Table knife
Couteau de table
217 mm · 8⅞ in.



06.0047.1050

Dessertlöffel
Dessert spoon
Cueillir à dessert
180 mm · 7⅛ in.



06.0047.1060

Dessertgabel
Dessert fork
Fourchette à dessert
175 mm · 6⅞ in.



06.0047.1850

Dessertmesser
Dessert knife
Couteau à dessert
201 mm · 7⅝ in.



06.0047.1100

Kaffeelöffel
Coffee spoon
Cueillir à café
139 mm · 5⅞ in.



06.0047.1110

Moccalöffel
Demi-tasse spoon
Cueillir à moka
118 mm · 4⅝ in.



06.0047.1730

Fischmesser
Fish knife
Couteau à poisson
203 mm · 8 in.



06.0047.1150

Fischgabel
Fish fork
Fourchette à poisson
180 mm · 7⅛ in.



06.0047.1210

Limonadenlöffel
Iced tea spoon
Cueillir à soda
190 mm · 7½ in.



06.0047.1630

Runder Suppenlöffel
Round soup spoon
Cueillir rond à bouillon
178 mm · 7 in.



06.0047.1750

Nachspeisengabel
Dessert fork
Fourchette à dessert
142 mm · 5⅞ in.

Besteck-Einzelteile
Serving pieces
pièces à servir

18/10

18/10

18/10

06.0047.1XX0

¹⁾ Hohlheft (18/10)
hollow handle (18/10)
orfèvre (18/10)

²⁾ ohne Wellenschliff
without serrated blade
sans lame crantée

³⁾ Designvariante
alternative design
variante de design





Universalzange, All purpose tongs, Pince universelle

Länge length		18/10	
mm	in.	18/10	
230	9 ¹ / ₁₆		60.5446.0000



Salatzange, Salad tongs, Pince à salade

Länge length		18/10	
mm	in.	18/10	
295	11 ⁵ / ₈		60.5438.0000



Zange, Tongs, Pince

Länge length		18/10	
mm	in.	18/10	
240	9 ⁷ / ₁₆		60.5475.0000



Spaghettizange, Spaghetti tongs, Pince à spaghetti

Länge length		18/10	
mm	in.	18/10	
240	9 ⁷ / ₁₆		60.5476.0000



Vorlegelöffel für Chafing Dish, Serving spoon for Chafing Dish, Cuiller à servir pour Chafing Dish

Länge length		18/10	versilbert silver plated
mm	in.	18/10	
400	15 ³ / ₄	12.5072.4000	13.6072.4000



Vorlegegabel für Chafing Dish, Serving fork for Chafing Dish, Fourchette à servir pour Chafing Dish

Länge length		18/10	versilbert silver plated
mm	in.	18/10	
400	15 ³ / ₄	12.5073.4000	13.6073.4000



Vorlegelöffel, Serving spoon, Cuiller à servir

Länge length		18/10	versilbert silver plated
mm	in.	18/10	
270	10 ⁵ / ₈	01.0045.1470	03.0145.3470



Vorlegegabel, Serving fork, Fourchette à servir

Länge length		18/10	versilbert silver plated
mm	in.	18/10	
270	10 ⁵ / ₈	01.0045.1480	03.0145.3480

Vorlegabel, Serving fork, Fourchette à servir

Länge length	18/10 18/10	versilbert silver plated
mm in.		
193 7 ⁵ / ₈	01.0045.1450	03.0145.3450

Tranchiermesser, Carving knife, Couteau à découper

Länge length	18/10 18/10	versilbert silver plated
mm in.		
250 9 ¹³ / ₁₆	01.0032.1500	03.0132.3500

Tranchiergabel, Carving fork, Fourchette à découper

Länge length	18/10 18/10	versilbert silver plated
mm in.		
225 8 ⁷ / ₈	01.0032.1510	03.0132.3510

Dressinglöffel, Dressing spoon, Cuiller à dressing

Länge length	18/10 18/10	versilbert silver plated
mm in.		
270 10 ⁵ / ₈	01.0045.1300	03.0145.3300

Gemüselöffel, Vegetable spoon, Cuiller à légumes

Länge length	18/10 18/10	versilbert silver plated
mm in.		
203 8	01.0045.1340	03.0145.3340

Saucenlöffel, Sauce spoon, Cuiller à sauce

Länge length	18/10 18/10	versilbert silver plated
mm in.		
180 7 ¹ / ₁₆	01.0045.1370	03.0145.3370

Suppenschöpfer, Soup ladle, large, Louche grande

Länge length	18/10 18/10	versilbert silver plated
mm in.		
263 10 ³ / ₈	01.0045.1400	03.0145.3400

Portionsschöpfer, Soup ladle, small, Louche petite

Länge length	18/10 18/10	versilbert silver plated
mm in.		
206 8 ¹ / ₈	01.0045.1410	03.0145.3410





Bowlenlöffel, Punch bowl ladle, Cuiller à punch

Länge length		18/10 18/10	versilbert silver plated
mm	in.		
330	13	12.5058.0000	13.6058.0000



Tortenheber, Cake server, Pelle à tarte

Länge length		18/10 18/10	versilbert silver plated
mm	in.		
225	8 ⁷ / ₈	01.0045.1420	03.0145.3420



Tortmesser, Cake knife, Couteau à tarte

Länge length			18/10 18/10
mm	in.		
293	11 ⁹ / ₁₆		60.5444.0000



Käsemesser, Cheese knife, Couteau à fromage

Länge length			18/10 18/10
mm	in.		
260	10 ¹ / ₄		60.5469.0000



Steakhaus-Messer, Steakhouse knife, Couteau à steakhouse

Länge length		18/10 18/10	18/10 matt 18/10 satin finish
mm	in.		
253	9 ¹⁵ / ₁₆	12.5075.0010	12.5075.0000



Steakhaus-Gabel, Steakhouse fork, Fourchette à steakhouse

Länge length		18/10 18/10	18/10 matt 18/10 satin finish
mm	in.		
212	8 ³ / ₈	12.5077.0010	12.5077.0000



Party-Löffel, Party spoon, Cuiller à party

Länge length		18/10 18/10	versilbert silver plated
mm	in.		
134	5 ¹ / ₄	01.0005.1200	03.0105.3200



Universal-Löffel-Gabel, Comb. Spoon-Fork, Cuiller-Fourch. univ.

Länge length		18/10 18/10	versilbert silver plated
mm	in.		
184	7 ¹ / ₄	01.0048.1270	03.0148.3270

Gebäckzange, Pastry tongs, Pince à pâtisserie

Länge length	18/10 18/10	versilbert silver plated
mm in.		
175 6 ⁷ / ₈	12.5051.0000	13.6051.0000

Zuckerzange, Sugar tongs, Pince à sucre

Länge length	18/10 18/10	versilbert silver plated
mm in.		
90 3 ⁹ / ₁₆	12.5053.0000	13.6053.0000

Hummergabel, Lobster fork, Fourchette à homard

Länge length	18/10 18/10	versilbert silver plated
mm in.		
220 8 ¹¹ / ₁₆	12.5054.0000	13.6054.0000

Hummerzange, Lobster crack, Pince à homard

Länge length	18/10 18/10	
mm in.		
197 7 ⁹ / ₄	60.8942.0000	

Traubenschere, Grape scissors, Ciseaux à raisins

Länge length	18/10 18/10	versilbert silver plated
mm in.		
150 5 ⁷ / ₈	12.5055.0000	13.6055.0000

Nußknacker, Nut cracker, Casse-noix

Länge length		vernickelt nickel plated
mm in.		
170 6 ¹¹ / ₁₆	12.5057.0000	

Krümelschaufel, Crumb scraper, Ramasse-miettes

Länge length	18/10 18/10	versilbert silver-plated
mm in.		
230 9 ¹ / ₁₆	12.2154.0000	13.3154.0000

Krümelsammler, Table crumbler, Ramasse-miettes

Länge length	18/10 18/10	
mm in.		
150 5 ⁷ / ₈	60.5427.0000	





Kaviarmesser, Caviar knife, Couteau à caviar

Länge
length

mm	in.
137	5 ³ / ₈

Perlmutter
nacre

60.9194.0000



Kaviarschaufel, Caviar spoon, Cuiller à caviar

Länge
length

mm	in.
127	5

Perlmutter
nacre

60.9195.0000



Pizza/Steakmesser, Pizza/Steak knife, Couteau à pizza/à steak

Länge
length

mm	in.
236	9 ⁵ / ₁₆

18/10
18/10

56.0403.6045



Brötchenmesser, Roll knife, Couteau à petit pain

Länge
length

mm	in.
221	8 ¹¹ / ₁₆

18/10
18/10

56.0406.6045



Besteckständer, Cutlery holder, Porte-couverts

Länge length		Breite width		Höhe height		18/10 18/10
mm	in.	mm	in.	mm	in.	
250	9 ¹³ / ₁₆	160	6 ⁵ / ₁₆	300	11 ¹³ / ₁₆	12.0605.0000



NEUTRAL

Menüöffel, Table spoon, Cuiller de table

Länge length		18/10 18/10
mm	in.	
197	7 ³ / ₄	06.0547.1700



TREND

Menügabel, Table fork, Fourchette de table

Länge length		18/10 18/10
mm	in.	
193	7 ⁵ / ₈	06.0547.1710



TREND

Menümesser, Table knife, Couteau de table

Länge length		rostfreier Stahl stainless steel
mm	in.	
217	8 ⁹ / ₁₆	06.0547.1840



TREND

Kaffeelöffel, Coffee spoon, Cuiller à café

Länge length		18/10 18/10
mm	in.	
139	5 ¹ / ₂	06.0547.1100



TREND

Kuchengabel, Cake fork, Fourchette à gâteau

Länge length		18/10 18/10
mm	in.	
142	5 ⁹ / ₁₆	06.0547.1750



TREND

Ein glänzender Start in den Tag
A brilliant start into the day





FRÜHSTÜCK · BREAKFAST

DISPENSER

Saftdispenser, Juice dispenser, Dispenseur de jus

individuell höhenverstellbar, klare Kennzeichnung, tropffreier, hygienischer Auslauf, Kühlmöglichkeit durch Eisröhre (Zubehör).

individually height adjustable, clear labelling, non dripping hygienic spout, cooling with ice tube (accessory).

individuellement réglable en hauteur, caractérisation claire, sans goutte, hygiénique bec, refroidissez la manière avec tube à glace (accessoire).



Länge length		Breite width		Mindesthöhe min. height		Maximalhöhe max. height	
mm	in.	mm	in.	mm	in.	mm	in.
305	12	200	8	520	20 1/2	600	23 1/2
Inhalt mit Eisröhre cap. incl. ice tube		Inhalt ohne Eisröhre cap. w/o ice tube				18/10 18/10	
Ltr.	Ltr.	Ltr.	oz.				
5	175	6,5	227,5			57.0116.6040	

EXCELLENT

Saftdispenser, Juice dispenser, Dispenseur de jus

individuell höhenverstellbar, klare Kennzeichnung, tropffreier, hygienischer Auslauf, Kühlmöglichkeit durch Eisröhre (Zubehör).

individually height adjustable, clear labelling, non dripping hygienic spout, cooling with ice tube (accessory).

individuellement réglable en hauteur, caractérisation claire, sans goutte, hygiénique bec, refroidissez la manière avec tube à glace (accessoire).



Länge length		Breite width		Mindesthöhe min. height		Maximalhöhe max. height	
mm	in.	mm	in.	mm	in.	mm	in.
305	12	200	8	520	20 1/2	600	23 1/2
Inhalt mit Eisröhre cap. incl. ice tube		Inhalt ohne Eisröhre cap. w/o ice tube				18/10 18/10	
Ltr.	Ltr.	Ltr.	oz.				
5	175	6,5	227,5			57.0117.6040	

ARTE

Milchdispenser, Milk dispenser, Dispenseur de lait

individuell höhenverstellbar, klare Kennzeichnung, tropffreier, hygienischer Auslauf, Kühlmöglichkeit durch Eisröhre (Zubehör).

individually height adjustable, clear labelling, non dripping hygienic spout, cooling with ice tube (accessory).

individuellement réglable en hauteur, caractérisation claire, sans goutte, hygiénique bec, refroidissez la manière avec tube à glace (accessoire).

Länge length		Breite width		Mindesthöhe min. height		Maximalhöhe max. height	
mm	in.	mm	in.	mm	in.	mm	in.
305	12	200	8	520	20½	600	23½
Inhalt mit Eisröhre cap. incl. ice tube		Inhalt ohne Eisröhre cap. w/o ice tube				18/10 18/10	
Ltr.	Ltr.	Ltr.	oz.				
5	175	6,5	227,5			57.0118.6040	



EXCELLENT

Milchdispenser, Milk dispenser, Dispenseur de lait

individuell höhenverstellbar, klare Kennzeichnung, tropffreier, hygienischer Auslauf, Kühlmöglichkeit durch Eisröhre (Zubehör).

individually height adjustable, clear labelling, non dripping hygienic spout, cooling with ice tube (accessory).

individuellement réglable en hauteur, caractérisation claire, sans goutte, hygiénique bec, refroidissez la manière avec tube à glace (accessoire).

Länge length		Breite width		Mindesthöhe min. height		Maximalhöhe max. height	
mm	in.	mm	in.	mm	in.	mm	in.
305	12	200	8	520	20½	600	23½
Inhalt mit Eisröhre cap. incl. ice tube		Inhalt ohne Eisröhre cap. w/o ice tube				18/10 18/10	
Ltr.	Ltr.	Ltr.	oz.				
5	175	6,5	227,5			57.0119.6040	



ARTE

DISPENSER



Eisröhre, Ice tube, Tube à glace
mit Crash Ice zu befüllen. Passend zu Saft- und Milchdispensern,
to be filled with crash ice. Fitting for all juice and milk dispensers,
rempli de glace crash. Convient pour dispenseur de jus et lait

Inhalt cap.		Höhe height		Ø-Außen Ø-outer		18/10
Ltr.	oz.	mm	in.	mm	in.	18/10
1	35	270	10 ³ / ₄	75	2 ¹⁵ / ₁₆	57.0120.6040

NEUTRAL



Transportgestell, Transport unit, Châssis de transport
für Saft- und Milchdispenserbehälter, for containers of juice and milk dispenser,
pour conteneur de dispenseur de jus et lait

Länge length		Breite width		Höhe height		18/10
mm	in.	mm	in.	mm	in.	18/10
180	7	150	6	8	3 ¹ / ₄	57.0121.6040

NEUTRAL

**Cerealiendispenser drehbar, Cereal dispenser rotatable,
Dispenseur de céréales rotatif**

mit 3 Behältern, drehbar, portionierte und hygienische Entnahme durch Drehen, leicht zu befüllen, spülmaschinene geeignet, Durchmesser Behälter 113 mm, Inhalt jeweils 3,5 Ltr., Unterstellhöhe 95 mm.

with 3 containers, turnable, hygienic portioning by turning, easy to refill, dishwasher safe, dia. container 4 7/16 in., capacity each container 123 oz., clear height 3 3/4 in.

avec 3 conteneur, rotatif, extrait portionné et hygiénique par tourner, facile à remplir, lave-vaisselle, dia. conteneur 113 mm, contenu chaque conteneur 3,5 Ltr., hauteur 95 mm.

Höhe height		Ø-Außen Ø-outer		18/10 18/10
mm	in.	mm	in.	
597	23 1/2	357	14	57.0122.6040



EXCELLENT

**Cerealiendispenser Reihenlösung, Cereal dispenser in-line,
Dispenseur de céréales in-line**

mit 3 Behältern, portionierte und hygienische Entnahme durch Drehen, leicht zu befüllen, spülmaschinene geeignet, Durchmesser Behälter 113 mm, Inhalt jeweils 3,5 Ltr., Unterstellhöhe 95 mm.

with 3 containers, turnable, hygienic portioning by turning, easy to refill, dishwasher safe, dia. container 4 7/16 in., capacity each container 123 oz., clear height 3 3/4 in.

avec 3 conteneur, extrait portionné et hygiénique par tourner, facile à remplir, lave-vaisselle, dia. conteneur 113 mm, contenu chaque conteneur 3,5 Ltr., hauteur 95 mm.

Länge length		Breite width		Höhe height		18/10 18/10
mm	in.	mm	in.	mm	in.	
390	15 1/4	250	9 3/4	597	23 1/2	57.0123.6040



EXCELLENT

DISPENSER

Cerealiendispenser Reihenlösung, Cereal dispenser in-line, Dispenseur de céréales in-line

mit 3 Behältern, portionierte und hygienische Entnahme durch Drehen, leicht zu befüllen, spülmaschinengeeignet, Durchmesser Behälter 113 mm, Inhalt jeweils 3,5 Ltr., Unterstellhöhe 95 mm.

with 3 containers, turnable, hygienic portioning by turning, easy to refill, dishwasher safe, dia. container 4 7/16 in., capacity each container 123 oz., clear height 3 3/4 in.

avec 3 conteneur, extrait portionné et hygiénique par tourner, facile à remplir, lave-vaisselle, dia. conteneur 113 mm, contenu chaque conteneur 3,5 Ltr., hauteur 95 mm.



Länge length		Breite width		Höhe height		18/10 18/10
mm	in.	mm	in.	mm	in.	
390	15 ¹ / ₄	250	9 ³ / ₄	597	23 ¹ / ₂	57.0124.6040

ARTE

Behälter für Cerealiendispenser, Container for cereal dispenser, Récipient pour dispenseur de céréales



Inhalt cap.		Höhe height		Ø-Außen Ø-outer		18/10 18/10
Ltr.	oz.	mm	in.	mm	in.	
3,5	123	500	19 ¹¹ / ₁₆	113	4 ⁷ / ₁₆	57.0127.6040

ARTE

Wandhalterung einfach, Wall mount single, Fixation murale simple
 einfache Montage an der Wand, für eine Dispenser-Röhre, inkl. Schrauben und Dübel,
 easy to fix at the wall, for 1 dispenser container, incl. screws and screw anchors,
 installation facile sur la paroi, pour un recipient, y compris vis et chevilles

Länge length		Breite width		Höhe height		18/10 18/10
mm	in.	mm	in.	mm	in.	
125	5	132	5¼	39	1½	57.0125.6040



NEUTRAL

Wandhalterung doppelt, Wall mount double, Fixation murale double
 einfache Montage an der Wand, für 2 Dispenser-Röhren, inkl. Schrauben und Dübel,
 easy to fix at the wall, for 2 dispenser pipes, incl. screws and screw anchors,
 installation facile sur la paroi, pour 2 recipients, y compris vis et chevilles

Länge length		Breite width		Höhe height		18/10 18/10
mm	in.	mm	in.	mm	in.	
250	9¾	132	5¼	39	1½	57.0126.6040



NEUTRAL

DISPENSER



Kanne mit Deckel, Jug with lid, Pot avec couvercle

Inhalt cap.		Höhe height		Kunststoff plastics
Ltr.	oz.	mm	in.	
1,4	49	245	9 ⁵ / ₈	57.0060.9900



SMART

Menage, Rack, Ménagère
für 3 Kannen, for 3 jugs, pour 3 pots

Länge length		Breite width		18/10 18/10
mm	in.	mm	in.	
350	13 ³ / ₄	210	8 ¹ / ₄	57.0061.6040



SMART

Rondell, Carousel, Rondelle
drehbar, für bis zu 6 Kannen, rotatable, for up to 6 jugs,
rotative, pour jusqu'à 6 pots

Länge length		Breite width		18/10
mm	in.	mm	in.	18/10
340	13 ³ / ₈	340	13 ³ / ₈	57.0062.6040



SMART

Saftständer, Juice stand, Support pour jus de fruits
 drehbar, ohne Einsätze, revolving, without inserts, pivotant, sans accessoires

Höhe height		Ø-Außen Ø-outer		18/10 18/10
mm	in.	mm	in.	
775	30 ¹ / ₂	516	20 ⁵ / ₁₆	12.2261.0000



NEUTRAL

Universalständer, Multi purpose stand, Support pour service universel
 drehbar, ohne Einsätze, revolving, without inserts, pivotant, sans insert

Höhe height		Ø-Außen Ø-outer		18/10 18/10
mm	in.	mm	in.	
760	29 ¹⁵ / ₁₆	497	19 ⁹ / ₁₆	12.2358.0000



NEUTRAL

Glaskrug, Glass jug, Cruche en verre

Inhalt cap.		Glas glass	
Ltr.	oz.		
2,00	70		50.8867.2000

 NEUTRAL

Kühlpellet, Cooling pellet, Pellet de réfrigération
 für Saftständer, for juice stand, pour support de jus de fruits

Ø-Außen Ø-outer		Kunststoff plastics	
mm	in.		
190	7½		60.8815.0000

 NEUTRAL

Glaseinsatz, Glass insert, Insert en verre

Inhalt cap.		Höhe height		Ø-Außen Ø-outer		Glas glass
Ltr.	oz.	mm	in.	mm	in.	
2,00	70	105	4⅛	230	9⅛	50.8361.2250

 NEUTRAL

Porzellan-Einsatz, Porcelain insert, Insert en porcelaine

Inhalt cap.		Höhe height		Ø-Außen Ø-outer		Porzellan porcelain
Ltr.	oz.	mm	in.	mm	in.	
0,80	28	88	3⅞	145	5⅞	50.8362.1500

 NEUTRAL

Universalschale, All purpose bowl, Bol universal

Inhalt cap.		Höhe height		Ø-Außen Ø-outer		18/10 18/10
Ltr.	oz.	mm	in.	mm	in.	
1,5	53	84	3 ⁵ / ₁₆	232	9 ¹ / ₈	60.5454.0000



NEUTRAL

Coffee Urn

Inhalt cap.		Breite width		Höhe height		18/10	versilbert silver-plated
Ltr.	oz.	mm	in.	mm	in.	18/10	
5,00	176	270	10 ⁵ / ₈	550	21 ⁵ / ₈	12.3477.0050	15.3477.0050
10,00	352	290	11 ⁷ / ₁₆	600	23 ⁵ / ₈	12.3477.0100	15.3477.0100
15,00	528	309	12 ³ / ₁₆	670	26 ³ / ₈	12.3477.0150	15.3477.0150



EXCLUSIVE

Coffee Urn

Inhalt cap.		Breite width		Höhe height		18/10	versilbert silver-plated
Ltr.	oz.	mm	in.	mm	in.	18/10	
5,00	176	253	9 ¹⁵ / ₁₆	480	18 ⁷ / ₈	12.2377.0050	15.2377.0050
10,00	352	290	11 ⁷ / ₁₆	570	22 ⁷ / ₁₆	12.2377.0100	15.2377.0100
15,00	528	309	12 ³ / ₁₆	650	25 ⁹ / ₁₆	12.2377.0150	15.2377.0150



EXCELLENT

Coffee Urn

Inhalt cap.		Breite width		Höhe height		18/10	versilbert silver-plated
Ltr.	oz.	mm	in.	mm	in.		
5,00	176	253	9 ¹⁵ / ₁₆	455	17 ¹⁵ / ₁₆	12.4877.0050	15.4877.0050
10,00	352	298	11 ³ / ₄	520	20 ¹ / ₂	12.4877.0100	15.4877.0100



PROFILE

Coffee Urn

Inhalt cap.		Breite width		Höhe height		18/10	versilbert silver-plated
Ltr.	oz.	mm	in.	mm	in.		
5,00	176	253	9 ¹⁵ / ₁₆	455	17 ¹⁵ / ₁₆	12.5277.0050	15.5277.0050
10,00	352	298	11 ³ / ₄	520	20 ¹ / ₂	12.5277.0100	15.5277.0100



ARTE

Coffee Urn
isoliert, insulated, isolée

Inhalt cap.		Breite width		Höhe height		18/10 18/10
Ltr.	oz.	mm	in.	mm	in.	
5,00	176	271	10 ¹¹ / ₁₆	523	20 ⁹ / ₁₆	12.2383.0050
10,00	352	315	12 ³ / ₈	611	24 ¹ / ₁₆	12.2383.0100



EXCELLENT

Elektroheizung, Heating element, Chauffage électrique
für Coffee Urn 5,00 ltr.
for coffee urn 176 oz.
pour coffee urn 5,00 ltr.

Ø-Außen Ø-outer		Heizleistung heating efficiency	Netzspannung line voltage	
mm	in.	Watt	Volt	
172	6 ³ / ₄	150	140-250	60.8881.0110
172	6 ³ / ₄	130	110-120	60.8881.0140



NEUTRAL

Elektroheizung, Heating element, Chauffage électrique
für Coffee Urn 10,00 ltr., 15,00 ltr., for coffee urn 352 oz., 528 oz.,
pour coffee urn 10,00 ltr., 15,00 ltr.

Ø-Außen Ø-outer		Heizleistung heating efficiency	Netzspannung line voltage	
mm	in.	Watt	Volt	
213	8 ³ / ₈	150	140-250	60.8881.0010
213	8 ³ / ₈	130	110-120	60.8881.0040



NEUTRAL

Brennerdose, Burner tin, Porte brûleur
für Brennpaste, for dry fuel burner, pour brûleur à gel

Ø-Außen		18/10
Ø-outer		18/10
mm	in.	
94	3 ¹¹ / ₁₆	60.8884.0000



NEUTRAL

Kaffeekanne, Coffee pot, Cafetière

Inhalt cap.		18/10
Ltr.	oz.	
0,30	11	57.0087.6040
0,60	21	57.0088.6040
1,20	42	57.0089.6040



VISION

Teekanne, Tea pot, Théière

Inhalt cap.		18/10
Ltr.	oz.	
0,35	12	57.0090.6040
0,70	25	57.0091.6040



VISION

Milch- und Sahnebehälter, Milk jug, Pot à lait

Inhalt cap.		18/10
Ltr.	oz.	
0,18	6	57.0092.6040



Deckel mit Ausschnitt, Lid with cut-out, Couvercle avec découpe

Ø		18/10
mm	in.	
6	2 1/4	57.0094.6040

VISION

Zuckerbehälter, Sugar bowl, Sucrier

Inhalt cap.		18/10
Ltr.	oz.	
0,1	4	57.0093.6040



Deckel mit Ausschnitt, Lid with cut-out, Couvercle avec découpe

Ø		18/10
mm	in.	
6	2 1/4	57.0094.6040



VISION



Kaffeekanne, Coffee pot, Cafetière

Inhalt cap.		18/10	versilbert
Ltr. oz.		18/10	silver-plated
0,30	11	12.2102.0300	13.3102.0300
0,60	21	12.2102.0600	13.3102.0600
1,75	62	12.2102.1750	13.3102.1750

EXCELLENT



Teekanne, Tea pot, Théière

Inhalt cap.		18/10	versilbert
Ltr. oz.		18/10	silver-plated
0,35	12	12.2103.0350	13.3103.0350
0,70	25	12.2103.0700	13.3103.0700

EXCELLENT



Milchkanne, Milk jug, Pot à lait

Inhalt cap.		18/10	versilbert
Ltr. oz.		18/10	silver-plated
0,15	5	12.2104.0150	13.3104.0150
0,30	11	12.2104.0300	13.3104.0300

EXCELLENT



Zuckerdose, Sugar bowl, Sucrier

Inhalt cap.		18/10	versilbert
Ltr. oz.		18/10	silver-plated
0,25	9	12.2105.0250	13.3105.0250

EXCELLENT

Zuckerdose, Sugar bowl, Sucrier

Inhalt cap.		18/10 18/10	versilbert silver-plated
Ltr.	oz.		
0,20	7	12.2106.0200	13.3106.0200



 NEUTRAL

Milchkanne, Milk jug, Pot à lait

Inhalt cap.		18/10 18/10	versilbert silver-plated
Ltr.	oz.		
0,15	5	12.2203.0150	13.2203.0150



 AVANTGARDE

Zuckerdose, Sugar bowl, Sucrier

Inhalt cap.		18/10 18/10	versilbert silver-plated
Ltr.	oz.		
0,25	9	12.2206.0250	13.2206.0250



 AVANTGARDE

Kaffeekanne, Coffee pot, Cafetière

Inhalt cap.		18/10 18/10	versilbert silver-plated
Ltr.	oz.		
0,30	11	12.4709.0300	13.4709.0300
0,60	21	12.4709.0600	13.4709.0600
1,50	53	12.4709.1500	13.4709.1500



 TRADITION

Teekanne, Tea pot, Théière



Inhalt cap.		18/10	versilbert
Ltr. oz.		18/10	silver-plated
0,35	12	12.4707.0350	13.4707.0350
0,70	25	12.4707.0700	13.4707.0700

TRADITION

Milchkanne, Milk jug, Pot à lait



Inhalt cap.		18/10	versilbert
Ltr. oz.		18/10	silver-plated
0,15	5	12.4603.0150	13.4603.0150

TRADITION

Zuckerdose, Sugar bowl, Sucrier



Inhalt cap.		18/10	versilbert
Ltr. oz.		18/10	silver-plated
0,25	9	12.4604.0250	13.4604.0250

TRADITION

Kaffeekanne, Coffee pot, Cafetière



Inhalt cap.		18/10	versilbert
Ltr. oz.		18/10	silver-plated
0,30	11	12.4402.0300	13.4402.0300
0,60	21	12.4402.0600	13.4402.0600

PROFILE

Teekanne, Tea pot, Théière

Inhalt cap.		18/10 18/10	versilbert silver-plated
Ltr.	oz.		
0,35	12	12.4403.0350	13.4403.0350
0,70	25	12.4403.0700	13.4403.0700

 PROFILE

Milchkanne, Milk jug, Pot à lait

Inhalt cap.		18/10 18/10	versilbert silver-plated
Ltr.	oz.		
0,15	5	12.4404.0150	13.4404.0150
0,30	11	12.4404.0300	13.4404.0300
0,60	21	12.4404.0600	13.4404.0600

 PROFILE

Zuckerdose, Sugar bowl, Sucrier

Inhalt cap.		18/10 18/10	versilbert silver-plated
Ltr.	oz.		
0,25	9	12.4405.0250	13.4405.0250

 PROFILE

Kaffeekanne, Coffee pot, Cafetière
 doppelwandig, double-walled, double paroi

Inhalt cap.		18/10 18/10
Ltr.	oz.	
0,30	11	60.5330.0300
0,60	21	60.5330.0600
1,20	42	60.5330.1200

 NEUTRAL



Teekanne, Tea pot, Théière
 doppelwandig, double-walled, double paroi
 mit Teesieb, with tea strainer, avec passoire à thé

Inhalt cap.			18/10 18/10
Ltr.	oz.		
0,60	21	60.5329.0600	
1,20	42	60.5329.1200	

NEUTRAL



Milchkanne, Milk jug, Pot à lait
 doppelwandig, double-walled, double paroi

Inhalt cap.			18/10 18/10
Ltr.	oz.		
0,15	5	60.5330.0150	

doppelwandig, ohne Deckel, double-walled, without lid,
 double paroi sans couvercle

Inhalt cap.			18/10 18/10
Ltr.	oz.		
0,30	11	60.5327.0300	

NEUTRAL



Zuckerdose, Sugar bowl, Sucrier
 für Sticks, for sticks, pour sticks

Höhe height			Ø-Außen Ø-outer	18/10 18/10
mm	in.	mm	in.	
80	3 ¹ / ₈	50	1 ¹⁵ / ₁₆	60.5306.0150

NEUTRAL



Zuckerdose, Sugar bowl, Sucrier
 für Sticks, for sticks, pour sticks

Höhe height			Ø-Außen Ø-outer	18/10 18/10
mm	in.	mm	in.	
57	2 ⁴ / ₁₆	77	3 ¹ / ₁₆	60.5307.0250

NEUTRAL

Zuckerbox, Sugar box, Boî à sucre
für Zuckerbriefchen, for sugar wraps, pour billet de sucre

Länge length		Höhe height		Tiefe depth		18/10	versilbert silver-plated
mm	in.	mm	in.	mm	in.	18/10	
110	24 ¹⁰ / ₁₆	45	11 ² / ₁₆	40	1 ⁹ / ₁₆	12.5060.0000	13.6060.0000



NEUTRAL

Isolierkanne, Insulated beverage server, Pot isotherme

Inhalt cap.		18/10
Ltr.	oz.	18/10
0,30	11	60.8899.0300
0,60	21	60.8899.0600
1,10	39	60.8899.1100
1,40	49	60.8899.1500



NEUTRAL

Zitronenpresse, Lemon squeezer, Presse-citron

Länge length		Breite width		18/10
mm	in.	mm	in.	18/10
82	3 ¹ / ₄	69	2 ¹¹ / ₁₆	60.8828.0000



NEUTRAL

Teesieb, Tea strainer, Passoire à thé
mit Abstellschale, with drip stand, avec réceptacle

Länge length		Breite width		Höhe height		18/10	versilbert silver-plated
mm	in.	mm	in.	mm	in.	18/10	
168	6 ⁵ / ₈	67	2 ⁵ / ₈	26	1	12.2038.0000	13.3038.0000



NEUTRAL





Zuckerständer, Sugar server, Service à sucre
3-tlg., 3-part, 3 parties

Höhe height		18/10 18/10	versilbert silver-plated
mm	in.		
183	7 ³ / ₁₆	12.2250.0000	15.2250.0000



EXCELLENT

Zuckerständer, Sugar server, Service à sucre
4-tlg., für Milch und Zucker, 4-part, for milk and sugar,
4 parties, pour lait et sucre

Höhe height		18/10 18/10	versilbert silver-plated
mm	in.		
183	7 ³ / ₁₆	12.2265.0000	15.2265.0000



EXCELLENT

Zuckerständer, Sugar server, Service à sucre
5-tlg., für Milch und Zucker, 5-part, for milk and sugar,
5 parties, pour lait et sucre

Höhe height		18/10 18/10	versilbert silver-plated
mm	in.		
245	9 ⁵ / ₈	12.2350.0000	15.2350.0000



EXCELLENT

Zuckerständer, Sugar server, Service à sucre
mit Glaseinsatz, with glass insert, avec insert en verre

Höhe height		18/10 18/10	versilbert silver-plated
mm	in.		
140	5 ¹ / ₂	12.2351.0700	15.2351.0700

Glaseinsatz, Glas insert, Insert en verre

Höhe height		Ø		Glas glass
mm	in.	mm	in.	
35	1 ³ / ₈	69	2 ¹¹ / ₁₆	50.8368.0700



EXCELLENT



Zuckerständer, Sugar server, Service à sucre

Höhe height		18/10 18/10	versilbert silver-plated
mm	in.		
112	4 ⁷ / ₁₆	12.4052.0650	15.4552.0650
146	5 ³ / ₄	12.4052.0900	15.4552.0900

EXCELLENT



Zuckerständer, Sugar server, Service à sucre
5-tlg., für Milch und Zucker, 5-part, for milk and sugar,
5 parties, pour lait et sucre

Höhe height		18/10 18/10	versilbert silver-plated
mm	in.		
142	5 ⁹ / ₁₆	12.4866.0000	15.4866.0000

PROFILE



Zuckerständer, Sugar server, Service à sucre
mit Glaseinsatz, with glass insert, avec insert en verre

Höhe height		18/10 18/10	versilbert silver-plated
mm	in.		
137	5 ³ / ₈	12.4851.0700	15.4851.0700

Glaseinsatz, Glas insert, Insert en verre

Höhe height		Ø Ø	Glas glass	
mm	in.	mm	in.	
35	1 ³ / ₈	69	2 ¹¹ / ₁₆	50.8368.0700

PROFILE



Zuckerständer, Sugar server, Service à sucre

Höhe height		18/10 18/10	versilbert silver-plated
mm	in.		
109	4 ⁵ / ₁₆	12.4852.0650	15.4852.0650

PROFILE

Ständer für Konfitürengläser, Stand for jam glasses,
Support pour verres à confiture
3-tlg., 3-part, 3 parties

Höhe height		18/10 18/10	versilbert silver-plated
mm	in.		
105	4 ¹ / ₈	12.4861.0000	15.4861.0000



PROFILE

Ständer für Konfitürengläser, Stand for jam glasses,
Support pour verres à confiture
3-tlg., 3-part, 3 parties

Höhe height		18/10 18/10	versilbert silver-plated
mm	in.		
115	4 ¹ / ₂	12.4161.0000	15.5161.0000



EXCELLENT

Ständer für Konfitürengläser, Stand for jam glasses,
Support pour verres à confiture
5-tlg. mit Vase, 5-part, with vase, 5 parties, avec vase

Höhe height		18/10 18/10	versilbert silver-plated
mm	in.		
200	7 ⁷ / ₈	12.2144.0000	13.5144.0000



NEUTRAL

Honig-Konfitürendose, Jam/honey pot, Service pour confitures et miel
3-tlg., 3-part, 3 parties

Höhe height		18/10 18/10	versilbert silver-plated
mm	in.		
140	5 ¹ / ₂	12.2258.0700	15.2258.0700

Glaseinsatz, Glas insert, Insert en verre

Höhe height		Ø		Glas glass
mm	in.	mm	in.	
35	1 ³ / ₈	69	2 ¹¹ / ₁₆	50.8368.0700



EXCELLENT



Honig-Konfitürendose, Jam/honey pot, Service pour confitures et miel
3-tlg., 3-part, 3 parties

Höhe height		18/10 18/10		versilbert silver-plated
mm	in.			
134	5 ¹ / ₄			12.4958.0700 15.4958.0700

Glaseinsatz, Glas insert, Insert en verre

Höhe height		Ø Ø		Glas glass
mm	in.	mm	in.	
35	1 ³ / ₈	69	2 ¹¹ / ₁₆	50.8368.0700

PROFILE

Eierbecher, Egg cup, Coquetier

Höhe height		Ø-Außen Ø-outer		18/10 18/10
mm	in.	mm	in.	
20	1 ³ / ₁₆	86	3 ³ / ₈	60.8826.0000



NEUTRAL

Brotkorb, Bread basket, Corbeille à pain
oval, ovale

Länge length		Breite width		Höhe height		18/10 18/10	versilbert silver-plated
mm	in.	mm	in.	mm	in.		
308	12 ¹ / ₈	165	6 ¹ / ₂	50	1 ¹⁵ / ₁₆	60.5483.3080	60.7483.3080



NEUTRAL

Toastständer, Toast rack, Support à toast

Länge length		Breite width		Höhe height		18/10 18/10	versilbert silver-plated
mm	in.	mm	in.	mm	in.		
162	6 ³ / ₈	83	3 ¹ / ₄	61	2 ⁸ / ₁₆	60.5496.0000	60.7496.0000

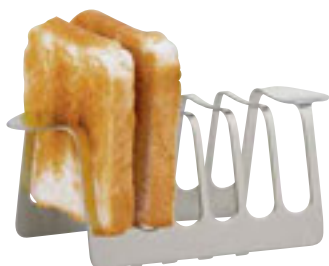

NEUTRAL

Servierblech, Serving tray, Plateau de service
oval, ovale

Länge length		Breite width		18/10 18/10	versilbert silver-plated
mm	in.	mm	in.		
221	8 ¹¹ / ₁₆	156	6 ¹ / ₈	12.2032.2300	13.3032.2300



NEUTRAL

Obstkorb, Fruit basket, Corbeille à fruits

Höhe height		Ø-Außen Ø-outer		18/10 18/10
mm	in.	mm	in.	
84	3 ⁵ / ₁₆	205	8 ¹ / ₁₆	60.5514.2050



NEUTRAL

Gebäckständer, Pastry stand, Porte-petits-fours

Höhe height		Ø-Außen Ø-outer		18/10 18/10	versilbert silver-plated
mm	in.	mm	in.		
90	3 1/2	162	6 3/8	12.4868.1600	13.4868.1600



PROFILE

Gebäckständer, Pastry stand, Porte-petits-fours
2-tlg., 2-part, 2 parties

Höhe height		Ø-Außen Ø-outer		18/10 18/10	versilbert silver-plated
mm	in.	mm	in.		
223	8 3/4	160	6 5/16	12.2269.1620	15.2269.1620
224	8 13/16	215	8 7/16	12.2269.2120	15.2269.2120



EXCELLENT

Gebäckständer, Pastry stand, Porte-petits-fours
3-tlg., 3-part, 3 parties

Höhe height		Ø-Außen Ø-outer		18/10 18/10	versilbert silver-plated
mm	in.	mm	in.		
320	12 5/8	215	8 7/16	12.2269.2130	15.2269.2130



EXCELLENT

Gebäckständer, Pastry stand, Porte-petits-fours
2-tlg., 2-part, 2 parties

Höhe height		Ø-Außen Ø-outer		18/10 18/10	versilbert silver-plated
mm	in.	mm	in.		
220	8 11/16	162	6 3/8	12.4869.1620	15.4869.1620



PROFILE

Gebäckständer, Pastry stand, Porte-petits-fours
 3-tlg., 3-part, 3 parties

Höhe height		Ø-Außen Ø-outer		18/10 18/10	versilbert silver-plated
mm	in.	mm	in.		
312	12 ⁵ / ₁₆	216	8 ¹ / ₂	12.4869.2130	15.4869.2130



PROFILE

Tortenplatte, Cake plate, Plat à tarte

Höhe height		Ø-Außen Ø-outer		18/10 18/10
mm	in.	mm	in.	
40	1 ⁹ / ₁₆	310	12 ³ / ₁₆	60.8906.3000



NEUTRAL

Tortennmesser, Cake knife, Couteau à tarte

Länge length		18/10 18/10
mm	in.	
293	11 ⁹ / ₁₆	60.5444.0000



NEUTRAL

Tortennmesserbehälter, Cake knife stand, Porte-couteau à tarte

Höhe height		18/10 18/10
mm	in.	
205	8 ¹ / ₁₆	60.5445.0000



NEUTRAL



Universalständer, Multi purpose stand, Support universel
für Teller Ø 21 cm, for plate Ø 8³/₄ inch, pour assiette Ø 21 cm

Breite width		Höhe height		18/10 18/10	versilbert silver-plated
mm	in.	mm	in.		
245	9 ⁵ / ₈	411	16 ³ / ₁₆	12.2078.0000	13.3078.0000

für Teller Ø 24 cm, for plate Ø 9⁷/₁₆ inch, pour assiette Ø 24 cm

Breite width		Höhe height		18/10 18/10	versilbert silver-plated
mm	in.	mm	in.		
290	11 ⁷ / ₁₆	400	15 ³ / ₄	12.2078.2400	13.3078.2400

NEUTRAL



Universalständer, Multi purpose stand, Support universel
für Teller Ø 21 cm, for plate Ø 8³/₄ inch, pour assiette Ø 21 cm

Breite width		Höhe height		18/10 18/10	versilbert silver-plated
mm	in.	mm	in.		
324	12 ³ / ₄	447	17 ⁵ / ₈	12.4178.0000	13.5178.0000

EXCELLENT



Afternoon Tea



Kulinarischer Trend mit Tradition

Der Five-O-Clock-Tea ist längst nicht mehr nur Tradition in England, sondern vielmehr Trend in der internationalen Gastronomie- und Hotellerieszene. Die drei neuen vierstöckigen Afternoon Tea Etageren aus hochwertigem Edelstahl bieten den verschiedenen Köstlichkeiten eine vielseitige große Bühne. Eine ergänzende Auswahl an weiteren Hepp Produkten rahmen die luxuriöse Tee-Zeremonie ein.

Culinary trend with tradition

A tradition in England, five o'clock tea has long since become an established trend on the international catering and hospitality scene. The three brand new four leveled Afternoon Tea stands are made of high-quality stainless steel. It offers the tasty delicacies a wide stage. An additional range of various Hepp products complete the exclusive tea ceremony.



Afternoon Tea Etagere, Afternoon Tea stand, Afternoon Tea étagère mit 4 Ebenen für 3 Teller Ø 24 - 31 cm und 1 Tablett 12.2037.3000, separat erhältlich,
with 4 levels for 3 plates Ø 9⁷/₁₆ - 12¹/₄ inch and 1 tray 12.2037.3000, available separately,
avec 4 niveaux pour 3 assiettes Ø 24 - 31 cm et un plateau 12.2037.3000, vendu séparément

Breite width		Höhe height		57.0177.6040
mm	in.	mm	in.	
476	18 ³ / ₄	1175	46 ¹ / ₄	



ROYAL

Afternoon Tea Etagere, Afternoon Tea stand, Afternoon Tea étagère
 mit 4 Ebenen für 3 Teller Ø 24 - 31 cm und 1 Tablett 12.2037.3000, separat erhältlich,
 with 4 levels for 3 plates Ø 9⁷/₁₆ - 12¹/₄ inch and 1 tray 12.2037.3000, available separately,
 avec 4 niveaux pour 3 assiettes Ø 24 - 31 cm et un plateau 12.2037.3000, vendu séparément

Breite width		Höhe height		
mm	in.	mm	in.	
476	18 ³ / ₄	1215	47 ³ / ₄	57.0178.6040



EXCELLENT

Afternoon Tea Etagere, Afternoon Tea stand, Afternoon Tea étagère
 mit 4 Ebenen für 3 Teller Ø 24 - 31 cm und 1 Tablett 12.2037.3000, separat erhältlich,
 with 4 levels for 3 plates Ø 9⁷/₁₆ - 12¹/₄ inch and 1 tray 12.2037.3000, available separately,
 avec 4 niveaux pour 3 assiettes Ø 24 - 31 cm et un plateau 12.2037.3000, vendu séparément

Breite width		Höhe height		
mm	in.	mm	in.	
476	18 ³ / ₄	1221	48	57.0176.6040



ORIENT

Servieren wird zum 5-Sterne Erlebnis
Serving turns into a 5-star experience





MENÜ & BANKETT · MENU & BANQUET

Platzteller, Show plate, Assiette de présentation

Ø-Außen Ø-outer		Ø-Innen Ø-inner		18/10 18/10	versilbert silver-plated
mm	in.	mm	in.		
331	13 ^{1/16}	200	7 ^{7/8}	12.2099.3300	13.3099.3300



EXCELLENT

Platzteller, Show plate, Assiette de présentation

Ø-Außen Ø-outer		Ø-Innen Ø-inner		18/10 18/10	versilbert silver-plated
mm	in.	mm	in.		
330	13	205	8 ^{1/16}	12.2088.3300	13.3088.3300



PROFILE

Kugelglocke, Dome cover, Cloche ronde

Höhe height		Ø-Außen Ø-outer		18/10 18/10	versilbert silver-plated
mm	in.	mm	in.		
130	5 ^{1/8}	210	8 ^{1/4}	12.3105.2100	15.3105.2100
153	6	242	9 ^{1/2}	12.3105.2400	15.3105.2400
165	6 ^{1/2}	272	10 ^{11/16}	12.3105.2700	15.3105.2700



PROFILE

Kugelglocke, Dome cover, Cloche ronde

Höhe height		Ø-Außen Ø-outer		18/10 18/10	versilbert silver-plated
mm	in.	mm	in.		
124	4 ⁷ / ₈	210	8 ¹ / ₄	12.3102.2100	15.3102.2100
143	5 ⁵ / ₈	242	9 ¹ / ₂	12.3102.2400	15.3102.2400
157	6 ³ / ₁₆	272	10 ¹¹ / ₁₆	12.3102.2700	15.3102.2700

EXCELLENT

Kugelglocke, Dome cover, Cloche ronde

Länge length		Breite width		Höhe height		18/10 18/10	versilbert silver-plated
mm	in.	mm	in.	mm	in.		
215	8 ⁷ / ₁₆	215	8 ⁷ / ₁₆	150	5 ⁷ / ₈	12.5214.2150	15.5214.2150

ARTE

Gemüseschüssel, Vegetable dish, Légumier

Inhalt cap.		Ø-Außen Ø-outer		18/10 18/10	versilbert silver-plated
Ltr.	oz.	mm	in.		
0,30	11	130	5 ¹ / ₈	12.4008.1300	15.4508.1300
0,50	18	157	6 ³ / ₁₆	12.4008.1600	15.4508.1600
0,90	32	190	7 ¹ / ₂	12.4008.1900	15.4508.1900

Deckel, Lid, Couvercle

Ø-Außen Ø-outer		18/10 18/10	versilbert silver-plated
mm	in.		
128	5 ¹ / ₁₆	12.2211.1300	15.2211.1300
158	6 ¹ / ₄	12.2211.1600	15.2211.1600
189	7 ⁷ / ₁₆	12.2211.1900	15.2211.1900

EXCELLENT

Servierschüssel, Serving dish, Plat à servir
oval, ovale

Inhalt cap.		Länge length		Breite width		18/10 18/10	versilbert silver-plated
Ltr.	oz.	mm	in.	mm	in.		
1,40	49	351	13 ¹³ / ₁₆	200	7 ⁷ / ₈	12.4000.3400	15.4500.3400

Deckel, Lid, Couvercle
oval, ovale

Länge length		Breite width		18/10 18/10	versilbert silver-plated
mm	in.	mm	in.		
354	13 ¹⁵ / ₁₆	203	8	12.2503.3400	15.2503.3400



EXCELLENT

Suppenschüssel, Soup tureen, Soupière

Inhalt cap.		Ø-Außen Ø-outer		18/10 18/10	versilbert silver-plated
Ltr.	oz.	mm	in.		
0,70	25	170	6 ¹¹ / ₁₆	12.2248.1600	15.2248.1600
2,00	70	218	8 ⁹ / ₁₆	12.2248.2100	15.2248.2100

Deckel mit Einschnitt, Lid with hole, Couvercle avec encoche

Ø-Außen Ø-outer		18/10 18/10	versilbert silver-plated
mm	in.		
177	6 ¹⁵ / ₁₆	12.2249.1600	15.2249.1600
222	8 ³ / ₄	12.2249.2100	15.2249.2100



EXCELLENT

Servierschüssel, Serving dish, Plat à servir
oval, ovale

Inhalt cap.		Länge length		Breite width		18/10 18/10	versilbert silver-plated
Ltr.	oz.	mm	in.	mm	in.		
1,40	49	351	13 ¹³ / ₁₆	200	7 ⁷ / ₈	12.4800.3400	15.4800.3400

Deckel, Lid, Couvercle
oval, ovale

Länge length		Breite width		18/10 18/10	versilbert silver-plated
mm	in.	mm	in.		
354	13 ¹⁵ / ₁₆	203	8	12.4803.3400	15.4803.3400



PROFILE

Sauciere, Sauce boat, Saucière

Inhalt cap.		18/10 18/10	versilbert silver-plated
Ltr.	oz.		
0,10	4	12.2316.0100	13.2316.0100
0,20	7	12.2316.0200	13.2316.0200
0,30	11	12.2316.0300	13.2316.0300
0,45	16	12.2316.0450	13.2316.0450



EXCELLENT

Sauciere, Sauce boat, Saucière

Inhalt cap.		18/10 18/10	versilbert silver-plated
Ltr.	oz.		
0,10	4	12.2215.0100	13.2215.0100
0,20	7	12.2215.0200	13.2215.0200
0,30	11	12.2215.0300	13.2215.0300



EXCELLENT

Sauciere, Sauce boat, Saucière

Inhalt cap.		18/10 18/10	versilbert silver-plated
Ltr.	oz.		
0,10	4	12.4816.0100	13.4816.0100
0,20	7	12.4816.0200	13.4816.0200
0,30	11	12.4816.0300	13.4816.0300
0,45	16	12.4816.0450	13.4816.0450



PROFILE

Servierplatte, Serving platter, Plat à servir
oval, ovale

Länge length		Breite width		18/10 18/10	versilbert silver-plated
mm	in.	mm	in.		
476	18 ³ / ₄	313	12 ⁵ / ₁₆	60.8902.4700	60.9102.4700



NEUTRAL

Servierplatte, Serving platter, Plat à servir
rund, round, rond

Ø-Außen Ø-outer		18/10 18/10	versilbert silver-plated
mm	in.		
319	12 ⁹ / ₁₆	60.8904.3200	60.9104.3200



NEUTRAL

1 Butterdose, Butter dish, Beurrier
2-tlg., 2-part, 2 parties

Höhe height		Ø-Außen Ø-outer		18/10 18/10	versilbert silver-plated
mm	in.	mm	in.		
41	1 ⁵ / ₈	116	4 ⁹ / ₁₆	12.2117.0000	13.3117.0000

2 Unterteller, Underliner, Sous-plat

Ø-Außen Ø-outer		18/10 18/10	versilbert silver-plated
mm	in.		
159	6 ¹ / ₄	12.2024.1600	13.3024.1600



NEUTRAL

Butterdose, Butter dish, Beurrier
2-tlg., 2-part, 2 parties

Höhe height		Ø-Außen Ø-outer		18/10 18/10	versilbert silver-plated
mm	in.	mm	in.		
79	3 ¹ / ₈	89	3 ¹ / ₂	12.2218.0000	13.2218.0000

Porzellan-Einsatz, Porcelain insert, Insert en porcelaine
für Butterdose, for butter dish, pour beurrier

Höhe height		Ø-Außen Ø-outer		Porzellan porcelain
mm	in.	mm	in.	
41	1 ⁵ / ₈	60	2 ³ / ₈	50.8868.0000



EXCELLENT

Butterdose, Butter dish, Beurrier
2-tlg., 2-part, 2 parties

Höhe height		Ø-Außen Ø-outer		18/10 18/10	versilbert silver-plated
mm	in.	mm	in.		
76	3	89	3 ¹ / ₂	12.4918.0000	15.4918.0000

Porzellan-Einsatz, Porcelain insert, Insert en porcelaine
für Butterdose, for butter dish, pour beurrier

Höhe height		Ø-Außen Ø-outer		Porzellan porcelain
mm	in.	mm	in.	
41	1 ⁵ / ₈	60	2 ³ / ₈	50.8868.0000



PROFILE

Butterdose, Butter dish, Beurrier
2-tlg., 2-part, 2 parties

Höhe height		Ø-Außen Ø-outer		18/10 18/10	versilbert silver-plated
mm	in.	mm	in.		
72	2 ¹³ / ₁₆	90	3 ⁹ / ₁₆	60.5480.0000	60.7480.0000



EXCELLENT

Butterdose, Butter dish, Beurrier
4-tlg., 4-part, 4 parties

Höhe height		Ø-Außen Ø-outer		18/10 18/10	versilbert silver-plated
mm	in.	mm	in.		
69	2 ¹¹ / ₁₆	146	5 ³ / ₄	60.5426.0000	60.7426.0000



EXCELLENT

Krümelschaufel, Crumb scraper, Ramasse-miettes

Länge length		18/10 18/10	versilbert silver-plated
mm	in.		
230	9 ¹ / ₁₆	12.2154.0000	13.3154.0000



NEUTRAL

Krümelsammler, Table crumbler, Ramasse-miettes

Länge length		18/10 18/10
mm	in.	
150	5 ⁷ / ₈	60.5427.0000



NEUTRAL

Universalständer, Multi purpose stand, Support universel
für Teller Ø 21 cm, for plate Ø 8¼ inch, pour assiette Ø 21 cm

Breite width		Höhe height		18/10	versilbert silver-plated
mm	in.	mm	in.		
245	9 ⁵ / ₈	411	16 ³ / ₁₆	12.2078.0000	13.3078.0000

für Teller Ø 24 cm, for plate Ø 9⁷/₁₆ inch, pour assiette Ø 24 cm

Breite width		Höhe height		18/10	versilbert silver-plated
mm	in.	mm	in.		
290	11 ⁷ / ₁₆	400	15 ³ / ₄	12.2078.2400	13.3078.2400



NEUTRAL

Universalständer, Multi purpose stand, Support universel
für Teller Ø 21 cm, for plate Ø 8¼ inch, pour assiette Ø 21 cm

Breite width		Höhe height		18/10	versilbert silver-plated
mm	in.	mm	in.		
324	12 ³ / ₄	447	17 ⁵ / ₈	12.4178.0000	13.5178.0000



EXCELLENT

Universalständer, Multi purpose stand, Support universel
für Teller Ø 16 cm, for plate Ø 6⁵/₁₆ inch, pour assiette Ø 16 cm

Breite width		Höhe height		18/10	versilbert silver-plated
mm	in.	mm	in.		
184	7 ¹ / ₄	254	10	12.2079.0000	13.3079.0000



NEUTRAL

Sorbetbehälter, Sorbet pot, Pot à sorbet



Inhalt cap.		Höhe height		Ø-Außen Ø-outer		Ø-Innen Ø-inner		18/10
Ltr.	oz.	mm	in.	mm	in.	mm	in.	18/10
1,10	39	205	8 ¹ / ₁₆	165	6 ¹ / ₂	116	4 ⁹ / ₁₆	12.4084.0000

EXCELLENT

Sorbetbehälter, Sorbet pot, Pot à sorbet



Inhalt cap.		Höhe height		Ø-Außen Ø-outer		Ø-Innen Ø-inner		18/10
Ltr.	oz.	mm	in.	mm	in.	mm	in.	18/10
1,10	39	200	7 ⁷ / ₈	165	6 ¹ / ₂	116	4 ⁹ / ₁₆	12.4884.0000

PROFILE

Eisschale, Ice cream bowl, Coupe à glace auf Fuß, with foot, sur pied



Inhalt cap.		Höhe height		Ø-Außen Ø-outer		18/10	versilbert silver-plated
Ltr.	oz.	mm	in.	mm	in.	18/10	
0,10	4	45	1 ³ / ₄	105	4 ¹ / ₈	10.0730.1000	11.1730.1000

NEUTRAL

Eisbecher, Ice cream cup, Coupe à glace



Inhalt cap.		Höhe height		Ø-Außen Ø-outer		18/10	versilbert silver-plated
Ltr.	oz.	mm	in.	mm	in.	18/10	
0,20	7	119	4 ¹¹ / ₁₆	82	3 ¹ / ₄	10.0612.0000	11.1612.0000

NEUTRAL

Servier- und Menagentablett „S“, Serving tray „S“, Tableau à servir „S“
 passend für VISION Holz- und Porzellanschalen „S“,
 fitting for VISION wood and porcelain dishes „S“,
 approprié pour VISION bol en bois et en porcelaine „S“

Länge length		Breite width		Höhe height		18/10 18/10
mm	in.	mm	in.	mm	in.	
246	9 ¹¹ / ₁₆	118	4 ⁵ / ₈	20	¹³ / ₁₆	57.0095.6040

Servier- und Menagentablett „M“, Serving tray „M“, Tableau à servir „M“
 passend zu VISION Holz- und Porzellanschale „M“,
 fitting to VISION wood and porcelain dish „M“,
 approprié pour VISION bol en bois et en porcelaine „M“

Länge length		Breite width		Höhe height		18/10 18/10
mm	in.	mm	in.	mm	in.	
279	11	152	6	20	¹³ / ₁₆	57.0109.6040



VISION

Porzellanschale „S“ flach mit 3-Teilung, Porcelain dish „S“ with 3 divisions,
 Bol en porcelaine „S“ avec 3 divisions

Länge length		Breite width		Höhe height		Porzellan porcelain
mm	in.	mm	in.	mm	in.	
214	8 ⁷ / ₁₆	85	3 ³ / ₈	25	1	57.0104.9800



VISION

Porzellanschale „S“, Porcelain dish „S“, Bol en porcelain „S“

Länge length		Breite width		Höhe height		Porzellan porcelain
mm	in.	mm	in.	mm	in.	
217	8 ⁹ / ₁₆	89	3 ¹ / ₂	40	1 ⁹ / ₁₆	57.0105.9800

Porzellanschale „M“, Porcelain dish „M“, Bol en porcelain „M“

Länge length		Breite width		Höhe height		Porzellan porcelain
mm	in.	mm	in.	mm	in.	
247	9 ³ / ₄	119	4 ¹¹ / ₁₆	50	1 ¹⁵ / ₁₆	57.0106.9800



VISION

Holzschale „S“, Wood dish „S“, Bol en bois „S“

Länge length		Breite width		Höhe height		Holz wood
mm	in.	mm	in.	mm	in.	
217	8 ⁹ / ₁₆	89	3 ¹ / ₂	40	1 ⁹ / ₁₆	57.0107.9990

Holzschale „M“, Wood dish „M“, Bol en bois „M“

Länge length		Breite width		Höhe height		Holz wood
mm	in.	mm	in.	mm	in.	
247	9 ³ / ₄	119	4 ¹¹ / ₁₆	50	1 ¹⁵ / ₁₆	57.0108.9990



VISION

Brotkorb, Bread basket, Corbeille à pain
 rund, round, rond

Höhe height		Ø-Außen Ø-outer		18/10 18/10	versilbert silver-plated
mm	in.	mm	in.		
49	1 ¹⁵ / ₁₆	234	9 ³ / ₁₆	12.2137.2300	13.3137.2300

 NEUTRAL

Brotkorb, Bread basket, Corbeille à pain
 oval, ovale

Länge length		Breite width		Höhe height		18/10 18/10	versilbert silver-plated
mm	in.	mm	in.	mm	in.		
234	9 ³ / ₁₆	171	6 ³ / ₄	37	1 ¹ / ₂	12.2136.2300	13.3136.2300
275	10 ¹³ / ₁₆	183	7 ³ / ₁₆	50	1 ¹⁵ / ₁₆	12.2136.2700	13.3136.2700

 NEUTRAL

Brotkorb, Bread basket, Corbeille à pain
 oval, durchbrochen, oval, perforated, ovale, perforée

Länge length		Breite width		Höhe height		18/10 18/10	versilbert silver-plated
mm	in.	mm	in.	mm	in.		
234	9 ³ / ₁₆	171	6 ³ / ₄	37	1 ⁷ / ₁₆	12.2720.2300	13.3720.2300

 NEUTRAL

Brotkorb, Bread basket, Corbeille à pain
 oval, ovale

Länge length		Breite width		Höhe height		versilbert silver-plated
mm	in.	mm	in.	mm	in.	
188	7 ³ / ₈	135	5 ⁵ / ₁₆	53	2 ¹ / ₁₆	60.9188.2000
226	8 ⁷ / ₈	169	6 ⁵ / ₈	58	2 ⁵ / ₁₆	60.9188.2500
264	10 ⁶ / ₁₆	187	7 ⁶ / ₁₆	60	2 ⁶ / ₁₆	60.7419.2800

 NEUTRAL

Brotkorb, Bread basket, Corbeille à pain
oval, ovale

Länge length		Breite width		Höhe height		18/10 18/10	versilbert silver-plated
mm	in.	mm	in.	mm	in.		
308	12 ¹ / ₈	165	6 ¹ / ₂	50	1 ⁵ / ₁₆	60.5483.3080	60.7483.3080



NEUTRAL

Austerngestell, Oyster rack, Support à huîtres
 passend für 2 Größen 12.2037.3000 und 12.2037.3600,
 fit 2 tray sizes 12.2037.3000 and 12.2037.3600,
 approprié pour 2 diamètres de plateaux 12.2037.3000 et 12.2037.3600

Höhe height		Ø-Außen Ø-outer		18/10 18/10	versilbert silver-plated
mm	in.	mm	in.		
208	8 ³ / ₁₆	360	14 ³ / ₁₆	12.2132.3600	13.3132.3600

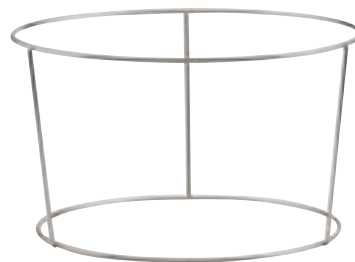

NEUTRAL

Serviertablett, Serving tray, Plateau de service
 rund, round, rond

Ø-Außen Ø-outer		18/10 18/10	versilbert silver-plated
mm	in.		
327	12 ⁷ / ₈	12.2037.3000	13.3037.3000
369	14 ¹ / ₂	12.2037.3600	13.3037.3600



NEUTRAL

Fingerschale, Finger bowl, Bol rince-doigts

Inhalt cap.		Höhe height		Ø-Außen Ø-outer		18/10 18/10	versilbert silver-plated
Ltr.	oz.	mm	in.	mm	in.		
0,25	9	49	1 ¹⁵ / ₁₆	105	4 ¹ / ₈	60.5447.0000	60.7447.0000



NEUTRAL

Unterteller, Underliner, Sous-plat

Ø-Außen Ø-outer		18/10 18/10	versilbert silver-plated
mm	in.		
159	6 ¹ / ₄	12.2024.1600	13.3024.1600



NEUTRAL



Chillcup

komplett für Scampis, complete for scampis, complet pour scampis

Inhalt cap.		Höhe height		Ø-Außen Ø-outer		18/10	versilbert silver-plated
Ltr.	oz.	mm	in.	mm	in.	18/10	
0,15	5	113	4 ⁷ / ₁₆	129	5 ¹ / ₁₆	12.2294.0000	15.2294.0000

NEUTRAL



Chillcup

komplett für Kaviar, complete for caviar, complet pour caviar

Inhalt cap.		Höhe height		Ø-Außen Ø-outer		18/10	versilbert silver-plated
Ltr.	oz.	mm	in.	mm	in.	18/10	
0,03	1	79	3 ¹ / ₈	127	5	12.2292.0000	15.2292.0000

NEUTRAL



Glaseinsatz, Glass insert, Insert en verre
für Chillcup, for chillcup, pour chillcup

Inhalt cap.		Höhe height		Ø-Außen Ø-outer		Glas glass
Ltr.	oz.	mm	in.	mm	in.	
0,15	5	51	2	110	4 ⁵ / ₁₆	50.8345.0000

NEUTRAL



Essig- / Ölflasche, Vinegar / oil bottle, Vinaigre / huile bouteille
 Glas und Edelstahl 18/10. Kombinierbar mit Servier- und Menagentablett „S“, Salz- und Pfefferstreuer VISION.
 Glass and stainless steel 18/10. Combinable with serving tray „S“, salt and pepper shaker VISION.
 Verre et acier inoxydable 18/10. Combinable avec plateau de service „S“, moulin à sel et moulin à poivre VISION.

Inhalt cap.		Höhe height		Ø-Außen Ø-outer		18/10
Ltr.	oz.	mm	in.	mm	in.	18/10
0,2	7	162	6 ³ / ₈	54	2 ¹ / ₈	57.0098.6040



VISION

Essig-Ölgestell, Vinegar and oil stand, Vinaigrier-Huilier

Höhe height		18/10	versilbert silver-plated
mm	in.	18/10	
210	8 ¹ / ₄	12.4141.0000	15.5141.0000

Glaseinsatz für Essig-Ölgestell, Glass insert for vinegar and oil stand, Verre de rechange pour Vinaigrier-Huilier

Inhalt cap.		Höhe height		Ø-Außen Ø-outer		Glas glass
Ltr.	oz.	mm	in.	mm	in.	
0,2	7	176	6 ¹⁵ / ₁₆	66	2 ⁵ / ₈	50.8335.0000



EXCELLENT

Essig-Ölgestell, Vinegar and oil stand, Vinaigrier-Huilier

Höhe height		18/10	versilbert silver-plated
mm	in.	18/10	
203	8	12.4841.0000	15.4841.0000

Glaseinsatz für Essig-Ölgestell, Glass insert for vinegar and oil stand, Verre de rechange pour Vinaigrier-Huilier

Inhalt cap.		Höhe height		Ø-Außen Ø-outer		Glas glass
Ltr.	oz.	mm	in.	mm	in.	
0,2	7	176	6 ¹⁵ / ₁₆	66	2 ⁵ / ₈	50.8335.0000



PROFILE



Salzmühle, Salt mill, Moulin à sel

Höhe height		Holz wood	
mm	in.		
135	5 ⁵ / ₁₆	60.5408.0000	

Pfeffermühle, Pepper mill, Moulin à poivre

Höhe height		Holz wood	
mm	in.		
135	5 ⁵ / ₁₆	60.5410.0000	

NEUTRAL

Salzmühle, Salt mill, Moulin à sel

Höhe height		18/10	versilbert silver-plated
mm	in.		
100	3 ¹⁵ / ₁₆	12.4867.0000	15.4867.0000



Pfeffermühle, Pepper mill, Moulin à poivre

Höhe height		18/10	versilbert silver-plated
mm	in.		
100	3 ¹⁵ / ₁₆	12.4865.0000	15.4865.0000

PROFILE



Salzstreuer, Salt shaker, Salière

Höhe height		Ø-Außen Ø-outer		18/10
mm	in.	mm	in.	
80	3 ¹ / ₈	37	1 ⁷ / ₁₆	57.0099.6040

Pfefferstreuer, Pepper shaker, Poivrier

Höhe height		Ø-Außen Ø-outer		18/10
mm	in.	mm	in.	
80	3 ¹ / ₈	37	1 ⁷ / ₁₆	57.0100.6040



VISION

Salzstreuer, Salt shaker, Salière
6 Loch, 6 hole, 6 trou

Höhe height		18/10 18/10	versilbert silver-plated
mm	in.		
70	2 ³ / ₄	60.5655.0700	60.7655.0700
90	3 ⁹ / ₁₆	60.5655.0900	60.7655.0900

Pfefferstreuer, Pepper shaker, Poivrière
1 Loch, 1 hole, 1 trou

Höhe height		18/10 18/10	versilbert silver-plated
mm	in.		
70	2 ³ / ₄	60.5656.0700	60.7656.0700
90	3 ⁹ / ₁₆	60.5656.0900	60.7656.0900



NEUTRAL

Salzstreuer, Salt shaker, Salière

Höhe height		18/10 18/10	versilbert silver-plated
mm	in.		
71	2 ¹³ / ₁₆	60.5486.0000	60.7486.0000

Pfefferstreuer, Pepper shaker, Poivrière

Höhe height		18/10 18/10	versilbert silver-plated
mm	in.		
71	2 ¹³ / ₁₆	60.5487.0000	60.7487.0000



NEUTRAL

Salzstreuer, Salt shaker, Salière

Höhe height		18/10 18/10	versilbert silver-plated
mm	in.		
76	3	60.5455.0000	60.7455.0000

Pfefferstreuer, Pepper shaker, Poivrière

Höhe height		18/10 18/10	versilbert silver-plated
mm	in.		
76	3	60.5456.0000	60.7456.0000



NEUTRAL

Menage, Cruet stand, Ménagère
2-tlg., 2-part, 2 parties

Höhe height		18/10 18/10	versilbert silver-plated
mm	in.		
142	5 ⁹ / ₁₆	12.4130.0000	15.5130.0000



EXCELLENT

Menage, Cruet stand, Ménagère
2-tlg., 2-part, 2 parties

Höhe height		18/10 18/10	versilbert silver-plated
mm	in.		
134	5 ¹ / ₄	12.4830.0000	15.4830.0000



PROFILE

Senfgefäß, Mustard pot, Moutardier

Höhe height		18/10 18/10	versilbert silver-plated
mm	in.		
102	4	12.2282.0000	15.2282.0000



EXCELLENT

Käsedose, Cheese dish, Fromagère

Höhe height		18/10 18/10	versilbert silver-plated
mm	in.		
81	3 ³ / ₁₆	12.2280.0000	15.2280.0000

Glaseinsatz, Glas insert, Insert en verre

Höhe height		Ø Ø	Glas glass
mm	in.	mm	in.
48	1 ⁷ / ₈	88	3 ⁷ / ₁₆
			50.8361.0850

 EXCELLENT

Käsedose, Cheese dish, Fromagère

Höhe height		18/10 18/10	versilbert silver-plated
mm	in.		
79	3 ¹ / ₈	12.4880.0000	15.4880.0000

Glaseinsatz, Glas insert, Insert en verre

Höhe height		Ø Ø	Glas glass
mm	in.	mm	in.
48	1 ⁷ / ₈	88	3 ⁷ / ₁₆
			50.8361.0850

 PROFILE

Zahnstocherbehälter, Toothpick stand, Porte cure-dents

Höhe height		18/10 18/10	versilbert silver-plated
mm	in.		
80	3 ¹ / ₈	12.2231.0000	13.2231.0000

 NEUTRAL



Leuchter, Candelabra, Chandelier

ohne Kerzen, without candles, sans bougies

Höhe ohne Kerzen, height without candles, hauteur sans bougies

Höhe height		18/10 18/10	versilbert silver-plated
mm	in.		
220	8 ¹¹ / ₁₆	60.5508.0030	60.7508.0030

EXCELLENT



Leuchter, Candelabra, Chandelier

ohne Kerzen, without candles, sans bougies

Höhe ohne Kerzen, height without candles, hauteur sans bougies

Höhe height		18/10 18/10	versilbert silver-plated
mm	in.		
286	11 ¹ / ₄	12.4843.0030	13.4843.0030

PROFILE



Leuchter, Candelabra, Chandelier

ohne Kerzen, without candles, sans bougies

Höhe ohne Kerzen, height without candles, hauteur sans bougies

Höhe height		18/10 18/10	versilbert silver-plated
mm	in.		
220	8 ¹¹ / ₁₆	60.5509.0050	60.7509.0050

EXCELLENT

Leuchter, Candelabra, Chandelier

ohne Kerzen, without candles, sans bougies

Höhe ohne Kerzen, height without candles, hauteur sans bougies

Höhe height		18/10 18/10	versilbert silver-plated
mm	in.		
303	11 ¹⁵ / ₁₆	12.4843.0050	13.4843.0050

 PROFILE

Bankett-Leuchter, Candelabra for banquet, Chandelier pour banquet

ohne Kerzen, without candles, sans bougies

Höhe ohne Kerzen, height without candles, hauteur sans bougies

Höhe height		18/10 18/10	versilbert silver-plated
mm	in.		
535	21 ¹ / ₁₆	12.4845.5400	13.4845.5400

 PROFILE



Leuchter, Candle holder, Chandelier
ohne Kerze, without candle, sans bougie
Höhe ohne Kerze, height without candle, hauteur sans bougie

Höhe height		Ø-Außen Ø-outer		18/10 18/10
mm	in.	mm	in.	
66	2 ⁵ / ₈	46	1 ¹³ / ₁₆	57.0103.6040
130	5 ¹ / ₈	46	1 ¹³ / ₁₆	57.0102.6040

VISION



Leuchter, Candelabra, Chandelier
ohne Kerze, without candle, sans bougie
Höhe ohne Kerze, height without candle, hauteur sans bougie

Höhe height		18/10 18/10	versilbert silver-plated
mm	in.		
180	7 ¹ / ₁₆	60.5507.1810	60.7507.1810

EXCELLENT



Leuchter, Candelabra, Chandelier
ohne Kerze, without candle, sans bougie
Höhe ohne Kerze, height without candle, hauteur sans bougie

Höhe height		18/10 18/10	versilbert silver-plated
mm	in.		
180	7 ¹ / ₁₆	12.4843.1800	13.4843.1800

PROFILE



Windlicht, Candle lamp, Photophore

Höhe height		Ø-Außen Ø-outer		18/10 18/10
mm	in.	mm	in.	
101	4	99	3 ⁷ / ₈	57.0097.6040

VISION

Windlicht, Candle lamp, Photophore

Höhe height		18/10 18/10	versilbert silver-plated
mm	in.		
218	8 ⁹ / ₁₆	60.5511.0000	60.7511.0000



EXCELLENT

Kerzenleuchter, Candle holder, Chandelier

Höhe height		18/10 18/10	
mm	in.		
195	7 ¹¹ / ₁₆	57.0044.6040	



STYLE

Kerzenleuchter, Candle holder, Chandelier

Höhe height		18/10 18/10	
mm	in.		
250	9 ¹³ / ₁₆	57.0045.6040	



STYLE

Tischlicht/ Teelichthalter, tea light holder, Support de bougie à chauffe-plat

Höhe height		18/10 18/10
mm	in.	
60	2 ⁹ / ₁₆	57.0047.6040



STYLE

Tischlicht/ Teelichthalter, tea light holder, Support de bougie à chauffe-plat

Höhe height		18/10 18/10
mm	in.	
90	3 ⁹ / ₁₆	57.0048.6040



STYLE

Blumenvase, Vase

Höhe height		18/10 18/10
mm	in.	
250	9 ¹³ / ₁₆	57.0046.6040



STYLE

Blumenvase, Vase

Höhe height		Ø-Außen Ø-outer		18/10 18/10
mm	in.	mm	in.	
130	5 ¹ / ₈	46	1 ¹³ / ₁₆	57.0101.6040



VISION

Blumenvase, Vase

Höhe height		18/10 18/10	versilbert silver-plated
mm	in.		
180	7 ¹ / ₁₆	60.5510.1800	60.7510.1800



EXCELLENT

Blumenvase, Vase

Höhe height		18/10 18/10	versilbert silver-plated
mm	in.		
180	7 ¹ / ₁₆	12.2246.1800	15.2246.1800



EXCELLENT

Blumenvase, Vase

Höhe height		18/10 18/10	versilbert silver-plated
mm	in.		
180	7 ¹ / ₁₆	12.4844.1800	13.4844.1800



PROFILE



Tischnummernständer, Table number stand, Porte pour numéro de table

Höhe height		18/10 18/10	versilbert silver-plated
mm	in.		
190	7½	60.5495.1900	60.7495.1900
460	18⅛	60.5495.4600	60.7495.4600

NEUTRAL



Tischnummernständer, Table number stand, Porte pour numéro de table

Höhe height		18/10 18/10	versilbert silver-plated
mm	in.		
220	8⅞	12.2263.2200	15.2263.2200
500	19⅞	12.2263.5000	15.2263.5000

NEUTRAL



Tischnummer, Table number, Numéro de table

Länge length		Breite width		Kunststoff plastics
mm	in.	mm	in.	
115	4½	110	4⅝	41.8050.0000

Tischnummer, Table number, Numéro de table

Länge length		Breite width		18/10 18/10	versilbert silver-plated
mm	in.	mm	in.		
115	4½	110	4⅝	12.2076.1000	13.3076.1000

NEUTRAL



Tischnummernständer, Table number stand, Porte pour numéro de table

Höhe height		18/10 18/10	versilbert silver-plated
mm	in.		
200	7⅞	12.2264.2000	13.2264.2000

NEUTRAL

Reservierschild, Reserved sign, Plaque de table avec réservé
RESERVIERT

Länge length		Breite width		18/10 18/10	versilbert silver-plated
mm	in.	mm	in.		
85	3 ³ / ₈	36	1 ⁷ / ₁₆	12.2453.0000	13.2453.0000

RESERVED

Länge length		Breite width		18/10 18/10	versilbert silver-plated
mm	in.	mm	in.		
85	3 ³ / ₈	36	1 ⁷ / ₁₆	12.2453.0100	13.2453.0100



NEUTRAL

Nichtraucherschild, No Smoking sign, Port non-fumeur

Länge length		Breite width		18/10 18/10	versilbert silver-plated
mm	in.	mm	in.		
60	2 ³ / ₈	56	2 ³ / ₁₆	12.2260.0000	13.2260.0000



NEUTRAL

Tischnummernschild, Table number sign, Port numéro de table

Länge length		Breite width		18/10 18/10	versilbert silver-plated
mm	in.	mm	in.		
60	2 ³ / ₈	60	2 ³ / ₈	12.2451.0000	13.2451.0000



NEUTRAL

Geschmackvolle Servierkunst rund um das Buffet

The tasteful art of buffet service





CHAFING DISH & BUFFET

SEQUENCE – Buffet Konzept · buffet concept



Ein Genuss für die Augen

Geschmackvolle Servierkunst hat einen neuen Namen: SEQUENCE – das innovative Buffet-Konzept mit außergewöhnlicher Formgebung und flexibler Handhabung. HEPP setzt mit dieser neuen rund 40-teiligen Kollektion neue Maßstäbe in der Speisenpräsentation. Dank aufeinander abgestimmter Module in vielen unterschiedlichen Größen und Höhen, asymmetrischer Formen und Materialkombinationen aus Holz, Porzellan, Edelstahl, Stoff, Corian und Kunststoff sind Ihrer Kreativität auf dem Buffet keine Grenzen mehr gesetzt. Ein exquisites Highlight für Ihre Gäste! Langeweile auf dem Buffet war gestern. Heute ist SEQUENCE.

A joy for the eyes

The tasteful art of service has a new name: SEQUENCE – the innovative buffet concept with unusual lines that is beautifully simple to use. With this new about 40-piece collection, HEPP is setting new standards in culinary presentation. The system is available in various dimensions, asymmetric forms, and material combinations, such as wood, porcelain, stainless steel, fabric, Corian and plastic – this array of harmoniously matched pieces means your creativity knows no bounds. An exquisite highlight for your guests! Boredom is a thing of the past – today belongs to SEQUENCE.



Rahmen L ergibt in Kombination mit Rahmen M und S ein Viereck (gleiches gilt für Rahmen M in Kombination mit S und XS) - so lässt sich hieraus wieder eine Ordnung schaffen.

When combined with frames M and S, frame L creates a square (the same applies to frame M in combination with S and XS), thereby re-establishing symmetry.



Brotkorb mit Stoffeinsatz in drei Größen L, M und S zum Einhängen in entsprechenden Rahmen Höhe 70 oder 100 mm.

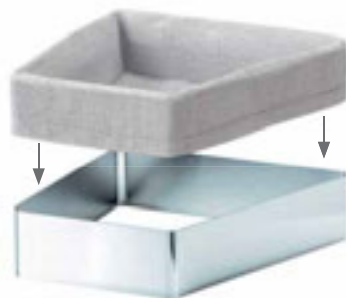

Breadbaskets with fabric insert available in sizes L, M, S can be hung in the respective 70 or 100mm frames.



SEQUENCE – Buffet Konzept · buffet concept



Durch die verschiedenen Höhen der Rahmen und der Podeste können mehrere Ebenen geschaffen werden.

The various heights of the frames and platforms come together to create a multi-level presentation stand.

Die Podestfüße und Platten (Holz oder Corian) sind einzeln zu bestellen und können somit auch ausgetauscht werden.

The platform feet and platters (wood or Corian) are available separately and can easily be interchanged.



Platten aus Holz, Corian sowie Porzellanschalen in verschiedenen Tiefen und Größen, zum Einlegen in Edelstahlrahmen Trapezform und in Edelstahlrahmen GN1/1.

Platters in wood and Corian, as well as porcelain bowls available in various sizes and volumes and slot seamlessly into the stainless steel trapezoid frames.

GN 1/1 fügt sich prima ins Gesamtsystem ein, da beispielsweise zwei Rahmen M aneinandergereiht annähernd die Höhe von GN 1/1 ergeben.

GN 1/1 blends seamlessly into the system as two M frames combined together create the required GN1/1 height.

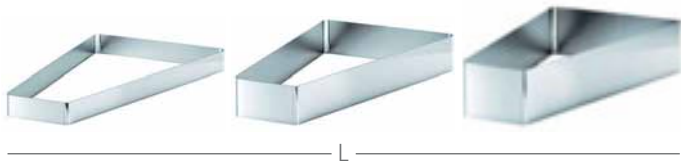

Edelstahlrahmen Trapezform in verschiedenen Höhen und Größen für unterschiedliche Anwendungen.

Trapezoid stainless steel frames are available in many sizes and heights for various applications.

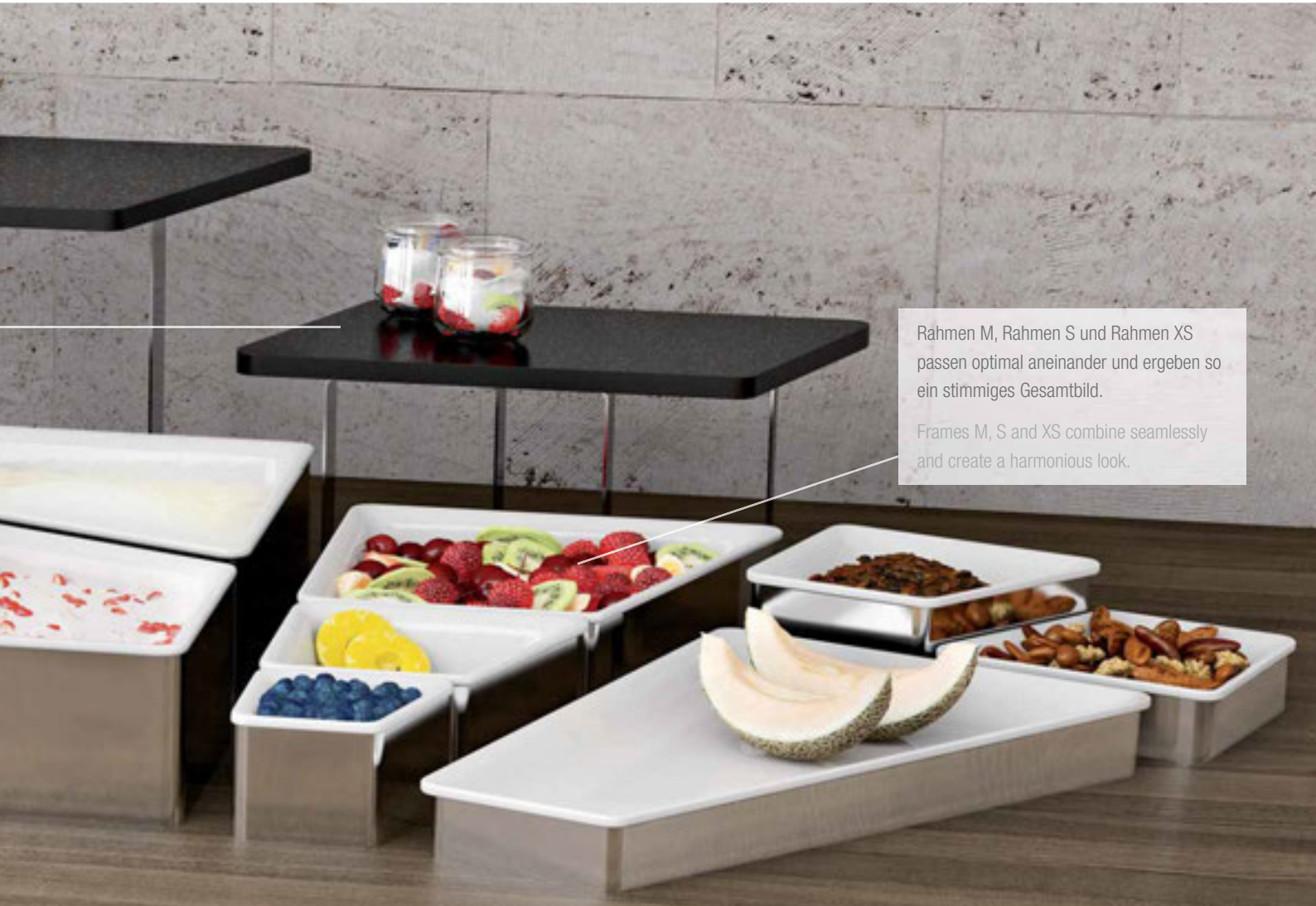

Rahmen M, Rahmen S und Rahmen XS passen optimal aneinander und ergeben so ein stimmiges Gesamtbild.
Frames M, S and XS combine seamlessly and create a harmonious look.



Eiswanne in verschiedenen Größen. Kühlmöglichkeit mittels Crash Ice oder Kühlakkus.

The Ice bath is available in various sizes – cooled using crushed ice or cooling batteries.



Podeste aus Holz oder Corian in zwei Größen zur Präsentation Ihrer Speisen und Waren.

Wooden or Corian platforms available in two sizes to show off your culinary delights.

SEQUENCE



Rahmen XS 40, Frame XS 40, Cadre XS 40

für Porzellanschale XS 35, for porcelain dish XS 35, pour bol en porcelaine XS 35

Länge length		Breite width		Höhe height		18/10 18/10
mm	in.	mm	in.	mm	in.	
110	4 ³ / ₄	95	3 ³ / ₄	40	1 ⁵ / ₈	57.0147.6040

Rahmen XS 70, Frame XS 70, Cadre XS 70

für alle Porzellanschalen XS, for all porcelain dishes XS,
pour tous bols en porcelaine XS

Länge length		Breite width		Höhe height		18/10 18/10
mm	in.	mm	in.	mm	in.	
110	4 ³ / ₄	95	3 ³ / ₄	70	2 ³ / ₄	57.0146.6040

Rahmen XS 100, Frame XS 100, Cadre XS 100

für alle Porzellanschalen XS, for all porcelain dishes XS,
pour tous bols en porcelaine XS

Länge length		Breite width		Höhe height		18/10 18/10
mm	in.	mm	in.	mm	in.	
110	4 ³ / ₄	95	3 ³ / ₄	100	4	57.0145.6040

SEQUENCE



Rahmen S 40, Frame S 40, Cadre S 40

für Porzellanschale S 35, for porcelain dish S 35, pour bol en porcelaine S 35

Länge length		Breite width		Höhe height		18/10 18/10
mm	in.	mm	in.	mm	in.	
170	6 ³ / ₄	146	5 ³ / ₄	40	1 ⁵ / ₈	57.0144.6040

Rahmen S 70, Frame S 40, Cadre S 70

für alle Porzellanschalen S, for all porcelain dishes S,
pour tous bols en porcelaine S

Länge length		Breite width		Höhe height		18/10 18/10
mm	in.	mm	in.	mm	in.	
170	6 ³ / ₄	146	5 ³ / ₄	70	2 ³ / ₄	57.0143.6040

Rahmen S 100, Frame S 100, Cadre S 100

für alle Porzellanschalen S, for all porcelain dishes S,
pour tous bols en porcelaine S

Länge length		Breite width		Höhe height		18/10 18/10
mm	in.	mm	in.	mm	in.	
170	6 ³ / ₄	146	5 ³ / ₄	100	4	57.0142.6040

SEQUENCE

Rahmen M 40, Frame M 40, Cadre M 100

für Porzellanschale M 35, for porcelain dish M 35, pour bol en porcelaine M 35

Länge length		Breite width		Höhe height		18/10 18/10
mm	in.	mm	in.	mm	in.	
270	10 ⁵ / ₈	245	9 ⁵ / ₈	40	1 ⁵ / ₈	57.0141.6040

Rahmen M 70, Frame M 70, Cadre M 70

für alle Porzellanschalen M, for all porcelain dishes M, pour tous bols en porcelaine M

Länge length		Breite width		Höhe height		18/10 18/10
mm	in.	mm	in.	mm	in.	
270	10 ⁵ / ₈	245	9 ⁵ / ₈	70	2 ³ / ₄	57.0140.6040

Rahmen M 100, Frame M 100, Cadre M 100

für alle Porzellanschalen M, for all porcelain dishes M, pour tous bols en porcelaine M

Länge length		Breite width		Höhe height		18/10 18/10
mm	in.	mm	in.	mm	in.	
270	10 ⁵ / ₈	245	9 ⁵ / ₈	100	4	57.0139.6040



SEQUENCE

Rahmen L 40, Frame L 40, Cadre L 40

für Porzellanschale L 35, alle Platten L, for porcelain dish L 35, all plates L, pour bol en porcelaine L 35, tous les plats L

Länge length		Breite width		Höhe height		18/10 18/10
mm	in.	mm	in.	mm	in.	
270	10 ⁵ / ₈	400	15 ³ / ₄	40	1 ⁵ / ₈	57.0138.6040

Rahmen L 70, Frame L 70, Cadre L 70

für alle Porzellanschalen L, Platten L, for all porcelain dishes L, plates L, pour tous bols en porcelaine L, plats L

Länge length		Breite width		Höhe height		18/10 18/10
mm	in.	mm	in.	mm	in.	
270	10 ⁵ / ₈	400	15 ³ / ₄	70	2 ³ / ₄	57.0137.6040

Rahmen L 100, Frame L 100, Cadre L 100

für alle Porzellanschalen L, Platten L, for all porcelain dishes L, plates L, pour tous bols en porcelaine L, plats L

Länge length		Breite width		Höhe height		18/10 18/10
mm	in.	mm	in.	mm	in.	
270	10 ⁵ / ₈	400	15 ³ / ₄	100	4	57.0136.6040



SEQUENCE

SEQUENCE



Rahmen GN 1/1 40, Frame GN 1/1 40, Cadre GN 1/1 40

für Platten GN 1/1 , for plates GN 1/1 , pour plats GN 1/1

Länge length		Breite width		Höhe height		18/10 18/10
mm	in.	mm	in.	mm	in.	
515	20 ¹ / ₄	310	12 ¹ / ₄	40	1 ⁵ / ₈	57.0150.6040

Rahmen GN 1/1 70, Frame GN 1/1 70, Cadre GN 1/1 70

für Porzellanschalen GN 1/1 , Platten GN 1/1 ,
for porcelain dishes GN 1/1 , plates GN 1/1 ,
pour bols en porcelaine GN 1/1 , plats GN 1/1

Länge length		Breite width		Höhe height		18/10 18/10
mm	in.	mm	in.	mm	in.	
515	20 ¹ / ₄	310	12 ¹ / ₄	70	2 ³ / ₄	57.0149.6040

Rahmen GN 1/1 100, Frame GN 1/1 100, Cadre GN 1/1 100

für Porzellanschalen GN 1/1 , Platten GN 1/1 ,
for porcelain dishes GN 1/1 , plates GN 1/1 ,
pour bols en porcelaine GN 1/1 , plats GN 1/1

Länge length		Breite width		Höhe height		18/10 18/10
mm	in.	mm	in.	mm	in.	
515	20 ¹ / ₄	310	12 ¹ / ₄	100	4	57.0148.6040

SEQUENCE



Porzellanschale XS 35, Porcelain dish XS 35, Bol en porcelaine XS 35

für Rahmen XS 100, 70, 40, for frame XS 100, 70, 40

Inhalt cap.		Länge length		Breite width		Höhe height		Porzellan porcelain
Ltr.	oz.	mm	in.	mm	in.	mm	in.	
0,14	4,9	122	4 ³ / ₄	102	4	35	1 ³ / ₈	57.0135.9800

Porzellanschale XS 65, Porcelain dish XS 65, Bol en porcelaine XS 65

für Rahmen XS 100, 70, for frame XS 100, 70, pour cadre XS 100, 70

Inhalt cap.		Länge length		Breite width		Höhe height		Porzellan porcelain
Ltr.	oz.	mm	in.	mm	in.	mm	in.	
0,24	8,4	122	4 ³ / ₄	102	4	65	2 ¹ / ₂	57.0134.9800

SEQUENCE

Porzellanschale S 35, Porcelain dish S 35, Bol en porcelaine S 35

für Rahmen S 100, 70, 40, for frame S 100, 70, 40, pour cadre S 100, 70, 40

Inhalt cap.		Länge length		Breite width		Höhe height		Porzellan porcelain
Ltr.	oz.	mm	in.	mm	in.	mm	in.	
0,37	13	183	7 ¹ / ₄	154	6 ¹ / ₈	35	1 ³ / ₈	57.0133.9800

Porzellanschale S 65, Porcelain dish S 65, Bol en porcelaine S 65

für Rahmen S 100, 70, for frame S 100, 70, pour cadre S 100, 70

Inhalt cap.		Länge length		Breite width		Höhe height		Porzellan porcelain
Ltr.	oz.	mm	in.	mm	in.	mm	in.	
0,70	24,6	183	7 ¹ / ₄	154	6 ¹ / ₈	65	2 ¹ / ₂	57.0132.9800



SEQUENCE

Porzellanschale M 35, Porcelain dish M 35, Bol en porcelaine M 35

für Rahmen M 100, 70, 40, for frame M 100, 70, 40, pour cadre M 100, 70, 40

Inhalt cap.		Länge length		Breite width		Höhe height		Porzellan porcelain
Ltr.	oz.	mm	in.	mm	in.	mm	in.	
1,20	42,2	285	11 ¹ / ₄	254	10	35	1 ³ / ₈	57.0131.9800

Porzellanschale M 65, Porcelain dish M 65, Bol en porcelaine M 65

für Rahmen M 100, 70, for frame M 100, 70, pour cadre M 100, 70

Inhalt cap.		Länge length		Breite width		Höhe height		Porzellan porcelain
Ltr.	oz.	mm	in.	mm	in.	mm	in.	
2,30	80,9	285	11 ¹ / ₄	254	10	65	2 ¹ / ₂	57.0130.9800



SEQUENCE

SEQUENCE



Porzellanschale L 35, Porcelain dish L 35, Bol en porcelaine L 35

für Rahmen L 100, 70, 40, for frame L 100, 70, 40, pour cadre L 100, 70, 40

Inhalt cap.		Länge length		Breite width		Höhe height		Porzellan porcelain
Ltr.	oz.	mm	in.	mm	in.	mm	in.	
1,50	52,8	285	11 ¹ / ₄	409	16 ¹ / ₈	35	1 ³ / ₈	57.0129.9800

Porzellanschale L 65, Porcelaine dish L 65, Bol en porcelaine L 65

für Rahmen L 100, 70, for frame L 100, 70, pour cadre L 100, 70

Inhalt cap.		Länge length		Breite width		Höhe height		Porzellan porcelain
Ltr.	oz.	mm	in.	mm	in.	mm	in.	
2,90	102	285	11 ¹ / ₄	409	16 ¹ / ₈	65	2 ¹ / ₂	57.0128.9800

SEQUENCE



Porzellan-Einsatz, Porcelain insert, Bac en porcelaine Gastronorm 1/1

Inhalt cap.		Länge length		Breite width		Höhe height		Porzellan porcelain
Ltr.	oz.	mm	in.	mm	in.	mm	in.	
7,3	257	530	20 ⁷ / ₈	325	12 ¹³ / ₁₆	20	¹³ / ₁₆	57.0071.9800
		530	20 ⁷ / ₈	325	12 ¹³ / ₁₆	65	2 ⁹ / ₁₆	50.8366.0110

NEUTRAL

Platte L Eiche, Plate L oak, Plat L chêne

für Rahmen L 100, 70, 40, for frame L 100, 70, 40, pour cadre L 100, 70, 40

Länge length		Breite width		Höhe height		Holz wood
mm	in.	mm	in.	mm	in.	
280	11	410	16 ¹ / ₈	15	⁵ / ₈	57.0151.9990

Platte L CORIAN®, Plate L CORIAN®, Plat L CORIAN®

für Rahmen L 100, 70, 40, for frame L 100, 70, 40, pour cadre L 100, 70, 40

Länge length		Breite width		Höhe height		Corian® Corian®
mm	in.	mm	in.	mm	in.	
280	11	410	16 ¹ / ₈	12	¹ / ₂	57.0151.9992



SEQUENCE

Platte GN ¹/₁ Eiche, Plate GN ¹/₁ oak, Plat GN ¹/₁ chêne

für Rahmen GN ¹/₁ 100, 70, 40, for frame GN ¹/₁ 100, 70, 40, pour cadre GN ¹/₁ 100, 70, 40

Länge length		Breite width		Höhe height		Holz wood
mm	in.	mm	in.	mm	in.	
530	20 ⁷ / ₈	325	12 ⁷ / ₈	15	⁵ / ₈	57.0152.9990

Platte GN ¹/₁ CORIAN®, Plate GN ¹/₁ CORIAN®, Plat GN ¹/₁ CORIAN®

für Rahmen GN ¹/₁ 100, 70, 40, for frame GN ¹/₁ 100, 70, 40, pour cadre GN ¹/₁ 100, 70, 40

Länge length		Breite width		Höhe height		Corian® Corian®
mm	in.	mm	in.	mm	in.	
530	20 ⁷ / ₈	325	12 ⁷ / ₈	12	¹ / ₂	57.0152.9992



SEQUENCE

SEQUENCE



Brotkorb S, Bread basket S, Corbeille à pain S

Stoffeinsatz für Rahmen 100, 70, fabric insert for frame 100, 70, insert en tissu pour cadre M 100, 70

Länge length		Breite width		Höhe height		Stoff fabric
mm	in.	mm	in.	mm	in.	
170	6 ³ / ₄	145	5 ³ / ₄	130	5 ¹ / ₈	57.0163.9990

Brotkorb M, Bread basket M, Cadre M

Stoffeinsatz für Rahmen M 100, 70, fabric insert for frame 100, 70, insert en tissu pour cadre M 100, 70

Länge length		Breite width		Höhe height		Stoff fabric
mm	in.	mm	in.	mm	in.	
270	10 ⁵ / ₈	245	9 ⁵ / ₈	130	5 ¹ / ₈	57.0160.9990

Brotkorb L, Bread basket L, Corbeille à pain L

Stoffeinsatz für Rahmen L 100, 70, fabric insert for frame 100, 70, insert en tissu pour cadre L 100, 70

Länge length		Breite width		Höhe height		Stoff fabric
mm	in.	mm	in.	mm	in.	
270	10 ⁵ / ₈	395	15 ⁵ / ₈	130	5 ¹ / ₈	57.0159.9990

SEQUENCE



Eiswanne M, Ice tray M, Bac réfrigérant M

Kunststoffeinsatz für Rahmen M 100, 70, plastic insert for frame M 100, 70, insert en plastique pour cadre M 100, 70

Länge length		Breite width		Höhe height		Kunststoff plastics
mm	in.	mm	in.	mm	in.	
262	10 ³ / ₈	238	9 ³ / ₈	60	2 ³ / ₈	57.0158.9990

Eiswanne L, Ice tray L, Bac réfrigérant L

Kunststoffeinsatz für Rahmen L 100, 70, plastic insert for frame L 100, 70, insert en plastique pour cadre M 100, 70

Länge length		Breite width		Höhe height		Kunststoff plastics
mm	in.	mm	in.	mm	in.	
262	10 ³ / ₈	392	15 ¹ / ₂	60	2 ³ / ₈	57.0157.9990

Eiswanne GN 1/1, Ice tray GN 1/1, Bac réfrigérant GN 1/1

Kunststoffeinsatz für Rahmen GN 1/1 100, 70, plastic insert for frame GN 1/1 100, 70, insert en plastique pour cadre GN 1/1 100, 70

Länge length		Breite width		Höhe height		Kunststoff plastics
mm	in.	mm	in.	mm	in.	
508	20	302	11 ⁷ / ₈	60	2 ³ / ₈	57.0164.9990

SEQUENCE

Podestplatte M Eiche, Pedestal plate M oak, Plat à palier M chêne

zu bestellen mit Podestfüßen M, to be ordered with pedestal feet M,
en commander avec pieds à palier M

Länge length		Breite width		Höhe height		Holz wood
mm	in.	mm	in.	mm	in.	
670	26 ³ / ₈	270	10 ⁵ / ₈	15	5 ⁷ / ₈	57.0153.9990

Podestfüße M, Pedestal feet M, Pieds à palier M

zu bestellen mit Podestplatten M, to be ordered with pedestal plates M,
en commander avec plats à palier M

Länge length		Breite width		Höhe height		18/10 18/10
mm	in.	mm	in.	mm	in.	
310	12 ¹ / ₄	40	1 ⁵ / ₈	250	9 ⁷ / ₈	57.0155.9990

SEQUENCE



Podestplatte M, Pedestal plate M, Plat à palier M CORIAN®

zu bestellen mit Podestfüßen M, to be ordered with pedestal feet M,
en commander avec pieds à palier M

Länge length		Breite width		Höhe height		Corian® Corian®
mm	in.	mm	in.	mm	in.	
670	26 ³ / ₈	270	10 ⁵ / ₈	12	1 ¹ / ₂	57.0153.9992

Podestfüße M, Pedestal feet M, Pieds à palier M

zu bestellen mit Podestplatten M, to be ordered with pedestal plates M,
en commander avec plats à palier M

Länge length		Breite width		Höhe height		18/10 18/10
mm	in.	mm	in.	mm	in.	
310	12 ¹ / ₄	40	1 ⁵ / ₈	250	9 ⁷ / ₈	57.0155.9990

SEQUENCE



Podestplatte S Eiche, Pedestal plate S oak, Plat à palier S chêne

zu bestellen mit Podestfüßen S, to be ordered with pedestal feet S,
en commander avec pieds à palier S

Länge length		Breite width		Höhe height		Holz wood
mm	in.	mm	in.	mm	in.	
410	16 ¹ / ₈	205	8 ¹ / ₈	15	5 ⁷ / ₈	57.0154.9990

Podestfüße S, Pedestal feet S, Pieds à palier S

zu bestellen mit Podestplatten S, to be ordered with pedestal plates S,
en commander avec plats à palier S

Länge length		Breite width		Höhe height		18/10 18/10
mm	in.	mm	in.	mm	in.	
190	7 ¹ / ₈	40	1 ⁵ / ₈	150	5 ⁷ / ₈	57.0156.9990

SEQUENCE



Podestplatte S, Pedestal plate S, Plat à palier S CORIAN®

zu bestellen mit Podestfüßen S, to be ordered with pedestal feet S,
en commander avec pieds à palier S

Länge length		Breite width		Höhe height		Corian® Corian®
mm	in.	mm	in.	mm	in.	
410	16 ¹ / ₈	205	8 ¹ / ₈	12	1 ¹ / ₂	57.0154.9992

Podestfüße S, Pedestal feet S, Pieds à palier S

zu bestellen mit Podestplatten S, to be ordered with pedestal plates S,
en commander avec plats à palier S

Länge length		Breite width		Höhe height		18/10 18/10
mm	in.	mm	in.	mm	in.	
190	7 ¹ / ₈	40	1 ⁵ / ₈	150	5 ⁷ / ₈	57.0156.9990

SEQUENCE



INDUCTION PLUS



Das Beste ist für Ihre Gäste gerade gut genug. Mit den HEPP Chafing Dishes INDUCTION PLUS bleibt das auch so. Die perfekte Wärmeverteilung durch den Kapselboden mit Aluminium-Kern hält Ihre kulinarischen Köstlichkeiten stets bei idealer Temperatur – während das Kondenswasserrücklaufsystem für eine lang anhaltende Frische sorgt.

Chafing Dishes INDUCTION PLUS erzielen auf Induktionsplatten verschiedenster Hersteller beste Ergebnisse. Da Tradition verpflichtet, werden sie auch auf Heizplatten und Brennstoffdosen höchsten Qualitätsansprüchen gerecht. Der hitzebeständige Griff, das gastronomiegerechte Material und der leicht abzunehmende, spülmaschinenfeste Glasdeckel machen den täglichen Umgang damit zum echten Genuss.

Only the best will do for your customers. HEPP INDUCTION PLUS chafing dishes will make sure they get only the best. The perfect heat distribution via the aluminium encapsulated bottom always keeps your culinary delights at the ideal temperature – while the condensation recirculating system ensures they stay fresh.

INDUCTION PLUS chafing dishes give optimum results on a wide range of induction hotplates. And because tradition is important, they also meet the highest quality standards with conventional hotplates and sterno fuel systems. The heat-resistant handle, the catering-grade material and the easy to remove, dishwasher-safe glass lid make them a real pleasure to use, day in, day out.





Chafing Dish Induktion rund, round, rond
 Bügelgriff, bow handle, poignée ronde

passend für Einsätze bis Tiefe 10 cm, induktionsgeeignet, Glasdeckel mit Bremse abnehmbar, alternativ mit Elektroheizung und Brennstoff beheizbar,
 fitting for inserts to depth 10 cm/ 4 inch, inductive, glass lid with brake removable, electrically and sterno heating possible,
 convient pour des inserts avec une profondeur de 10 cm, compatible induction, couvercle en verre avec brûleur amovible, alternative avec chauffage électrique et combustible

Höhe height		Ø		18/10	
mm	in.	mm	in.	18/10	
190	7½	390	15¼	57.0001.6040	



EXCELLENT

Chafing Dish Induktion rund, round, rond
 Griff 4-Kantprofil mattiert, satin finished handle profile 4-cornered,
 poignée finition satinée Profile

passend für Einsätze bis Tiefe 10 cm, induktionsgeeignet, Glasdeckel mit Bremse abnehmbar, alternativ mit Elektroheizung und Brennstoff beheizbar,
 fitting for inserts to depth 10 cm/ 4 inch, inductive, glass lid with brake removable, electrically and sterno heating possible,
 convient pour des inserts avec une profondeur de 10 cm, compatible induction, couvercle en verre avec brûleur amovible, alternative avec chauffage électrique et combustible

Höhe height		Ø		18/10	
mm	in.	mm	in.	18/10	
190	7½	390	15¼	57.0020.6040	



ARTE

Chafing Dish Induktion GN 2/3 , Chafing Dish Induction GN 2/3
 Bügelgriff, bow handle, poignée ronde

passend für Einsätze bis Tiefe 10 cm, induktionsgeeignet, Glasdeckel mit Bremse abnehmbar, alternativ mit Elektroheizung und Brennstoff beheizbar,
 fitting for inserts to depth 10 cm/ 4 inch, inductive, glass lid with brake removable, electrically and sterno heating possible,
 convient pour des inserts avec une profondeur de 10 cm, compatible induction, couvercle en verre avec brûleur amovible, alternative avec chauffage électrique et combustible

Länge length		Breite width		Höhe height		18/10
mm	in.	mm	in.	mm	in.	18/10
370	14½	450	17¾	190	7½	57.0002.6040

Maße inklusive Bremse und Griff
 Dimensions inclusive brake and handle
 Mesures incluant les freins et poignées



EXCELLENT

Chafing Dish Induktion GN 2/3 , Chafing Dish Induction GN 2/3
 Griff 4-Kantprofil mattiert, satin finished handle profile 4-cornered,
 poignée finition satinée Profile

passend für Einsätze bis Tiefe 10 cm, induktionsgeeignet, Glasdeckel mit Bremse
 abnehmbar, alternativ mit Elektroheizung und Brennstoff beheizbar,
 fitting for inserts to depth 10 cm/ 4 inch, inductive, glass lid with brake removable,
 electrically and sterno heating possible,
 convient pour des inserts avec une profondeur de 10 cm, compatible induction,
 couvercle en verre avec brûleur amovible, alternative avec chauffage électrique et
 combustible



Länge length		Breite width		Höhe height		18/10
mm	in.	mm	in.	mm	in.	18/10
370	14 1/2	450	17 3/4	190	7 1/2	57.0021.6040

Maße inklusive Bremse und Griff
 Dimensions inclusive brake and handle
 Mesures incluant les freins et poignées

ARTE

Buffetgestell rund, Buffet stand round, Support pour buffet rond
 Füße Rundprofil, feet profil round, pieds rond Profile

Höhe inklusive Chafing Dish 37 cm, height inclusive Chafing Dish 14 1/2 inch,
 hauteur inclusive Chafing Dish 37 cm



Höhe height		Ø		18/10
mm	in.	mm	in.	18/10
240	9 1/2	460	18	57.0007.6040

EXCELLENT

Buffetgestell rund, Buffet stand round, Support pour buffet rond
 Füße 4-Kantprofil mattiert, satin finished feet profile 4-cornered,
 4 pieds carrés finition satinée

Höhe inklusive Chafing Dish 37 cm, height inclusive Chafing Dish 14 1/2 inch,
 hauteur inclusive Chafing Dish 37 cm



Höhe height		Ø		18/10
mm	in.	mm	in.	18/10
240	9 1/2	470	18 1/2	57.0008.6040

ARTE

Buffetgestell GN $\frac{2}{3}$, Buffet stand GN $\frac{2}{3}$, Support pour buffet GN $\frac{2}{3}$
 FüÙe Rundprofil, feet profil round, pieds rond Profile

Höhe inklusive Chafing Dish 37 cm, height inclusive Chafing Dish 14 $\frac{1}{2}$ inch,
 hauteur inclusive Chafing Dish 37 cm

Länge length		Breite width		Höhe height		18/10 18/10
mm	in.	mm	in.	mm	in.	
440	17 $\frac{1}{4}$	400	15 $\frac{3}{4}$	240	9 $\frac{1}{2}$	57.0012.6040



EXCELLENT

Buffetgestell GN $\frac{2}{3}$, Buffet stand GN $\frac{2}{3}$, Support pour buffet GN $\frac{2}{3}$

FüÙe 4-Kantprofil mattiert , satin finished feet profile 4-cornered,
 4 pieds carrés finition satinée

Höhe inklusive Chafing Dish 37 cm, height inclusive Chafing Dish 14 $\frac{1}{2}$ inch,
 hauteur inclusive Chafing Dish 37 cm

Länge length		Breite width		Höhe height		18/10 18/10
mm	in.	mm	in.	mm	in.	
450	17 $\frac{3}{4}$	400	15 $\frac{3}{4}$	240	9 $\frac{1}{2}$	57.0013.6040



ARTE

Buffetgestell rund, Buffet stand round, Support pour table rond
 ohne Chafing Dish, without Chafing Dish, sans Chafing Dish

Höhe inklusive Chafing Dish 30 cm, Height inclusive Chafing Dish 11 $\frac{3}{4}$ inch,
 hauteur inclusive Chafing Dish 30 cm

Höhe height		Ø		18/10 18/10
mm	in.	mm	in.	
170	6 $\frac{3}{4}$	390	15 $\frac{1}{4}$	57.0005.6040



NEUTRAL



Buffetgestell GN 2/3 , Buffet stand GN 2/3 , Support pour buffet GN 2/3
ohne Chafing Dish, without Chafing Dish, sans Chafing Dish

Höhe inklusive Chafing Dish 30 cm, Height inclusive Chafing Dish 11 3/4 inch,
hauteur inclusive Chafing Dish 30 cm

Länge length		Breite width		Höhe height		18/10 18/10
mm	in.	mm	in.	mm	in.	
370	14 ⁹ / ₁₆	400	15 ¹² / ₁₆	170	6 ¹¹ / ₁₆	57.0006.6040

NEUTRAL

Suppenstation, Soup Station, Station potage
für Chafing Dish Ø 30 cm, rund, for Chafing Dish Ø 30 cm, round,
pour Chafing Dish rond, Ø 30 cm

Inhalt cap.		Ø-Außen Ø-outer		18/10 18/10
Ltr.	oz.	mm	in.	
4,50	158	345	13 ⁹ / ₁₆	12.2073.0000
9,00	317	345	13 ⁹ / ₁₆	60.8873.0000



NEUTRAL

Suppenstation, Soup station, Station potage
für Chafing Dish GN 2/3 , for Chafing Dish GN 2/3 , pour Chafing Dish GN 2/3

Inhalt cap.		Länge length		Breite width		18/10 18/10
Ltr.	oz.	mm	in.	mm	in.	
4,50	158	363	14 ⁹ / ₁₆	332	13 ¹ / ₁₆	57.0050.6040
9,00	317	363	14 ⁵ / ₁₆	332	13 ¹ / ₁₆	57.0051.6040



NEUTRAL

Porzellan-Einsatz, Porcelain insert, Bac en porcelaine
für Chafing Dish, for Chafing Dish, pour Chafing Dish

Inhalt cap.		Höhe height		Ø	Ø-Außen Ø-outer	Ø-Außen Ø-outer	Porzellan porcelain
Ltr.	oz.	mm	in.	mm	mm	in.	
3,00	106	70	2 ¹ / ₈	Ø 30 cm	335	13 ³ / ₁₆	60.8874.3000



NEUTRAL

Porzellan-Einsatz, Porcelain insert, Bac en porcelaine
für Chafing Dish, 2-tlg., for Chafing Dish, 2-part, pour Chafing Dish, 2 parties

Inhalt cap.		Höhe height		Ø	Ø-Außen Ø-outer	Ø-Außen Ø-outer	Porzellan porcelain
Ltr.	oz.	mm	in.	mm	mm	in.	
2,60	92	70	2 ¹ / ₈	Ø 30 cm	335	13 ³ / ₁₆	60.8879.3000



NEUTRAL

Porzellan-Einsatz, Porcelain insert, Bac en porcelaine
Gastronorm ¹/₃

Inhalt cap.		Länge length		Breite width		Höhe height		Porzellan porcelain
Ltr.	oz.	mm	in.	mm	in.	mm	in.	
1,9	67	175	6 ⁷ / ₈	325	12 ¹³ / ₁₆	65	2 ⁹ / ₁₆	50.8366.0130



NEUTRAL

Porzellan-Einsatz, Porcelain insert, Bac en porcelaine
Gastronorm ²/₃

Inhalt cap.		Länge length		Breite width		Höhe height		Porzellan porcelain
Ltr.	oz.	mm	in.	mm	in.	mm	in.	
4,65	164	354	13 ¹⁵ / ₁₆	325	12 ¹³ / ₁₆	65	2 ⁹ / ₁₆	50.8366.0230



NEUTRAL

Einsatz für Chafing Dish, Insert for Chafing Dish, Récipient pour Chafing Dish
Gastronorm 1/3

Inhalt cap.		Länge length		Breite width		Höhe height		18/10
Ltr.	oz.	mm	in.	mm	in.	mm	in.	18/10
2,50	88	176	6 ¹⁵ / ₁₆	325	12 ¹³ / ₁₆	65	2 ⁹ / ₁₆	60.8824.0130
3,75	132	176	6 ¹⁵ / ₁₆	325	12 ¹³ / ₁₆	100	3 ¹⁵ / ₁₆	60.8825.0130



NEUTRAL

Einsatz für Chafing Dish, Insert for Chafing Dish, Récipient pour Chafing Dish
Gastronorm 2/3

Inhalt cap.		Länge length		Breite width		Höhe height		18/10
Ltr.	oz.	mm	in.	mm	in.	mm	in.	18/10
5,50	194	354	13 ¹⁵ / ₁₆	325	12 ¹³ / ₁₆	65	2 ⁹ / ₁₆	60.8824.0230
9,00	317	354	13 ¹⁵ / ₁₆	325	12 ¹³ / ₁₆	100	3 ¹⁵ / ₁₆	60.8825.0230



NEUTRAL

Einsatz für Chafing Dish, Insert for Chafing Dish, Récipient pour Chafing Dish
rund, round, rond

Inhalt cap.		Höhe height	Ø	Ø-Außen Ø-outer	Ø-Außen Ø-outer	18/10	
Ltr.	oz.	mm	in.	mm	in.	18/10	
5,00	176	87	3 ⁷ / ₁₆	Ø 30 cm	335	13 ³ / ₁₆	60.8915.3010



NEUTRAL

Besteckablage, Rack for utensils, Support couvert à servir

Länge length		Breite width		Höhe height		18/10
mm	in.	mm	in.	mm	in.	18/10
280	11	120	4 ³ / ₄	70	2 ³ / ₄	57.0033.6040



Porzellanschale für Besteckablage, Porcelain bowl for rack for utensils,
Bac en porcelaine pour support couverts à servir

Länge length		Breite width		Höhe height		Porzellan porcelain
mm	in.	mm	in.	mm	in.	Porzellan porcelain
210	8 ¹ / ₄	90	3 ¹ / ₂	30	1 ¹ / ₄	57.0034.9800

NEUTRAL

Vorlegelöffel, Serving spoon, Cuiller à servir

Länge length		18/10 18/10	versilbert silver plated
mm	in.		
270	10 ⁵ / ₈	01.0045.1470	03.0145.3470



NEUTRAL

Vorlegabel, Serving fork, Fourchette à servir

Länge length		18/10 18/10	versilbert silver plated
mm	in.		
270	10 ⁵ / ₈	01.0045.1480	03.0145.3480



NEUTRAL

Zange, Tongs, Pince

Länge length		18/10 18/10	
mm	in.		
240	9 ⁷ / ₁₆		60.5475.0000



NEUTRAL

Suppenschöpfer, Soup ladle, large, Louche grande

Länge length		18/10 18/10	versilbert silver plated
mm	in.		
263	10 ³ / ₈	01.0045.1400	03.0145.3400



NEUTRAL

Elektroheizung regelbar, Heating element adjustable,
 Chauffage électrique réglable
 für / for / pour „Induction Plus“, Chafing Dish GN 1/1 , Ø 40 cm
 manuell regelbar, manually adjustable, manuellement réglable

Länge length		Breite width		Heizleistung heating efficiency	Netzspannung line voltage	
mm	in.	mm	in.	Watt	Volt	
250	9 ¹³ / ₁₆	200	7 ⁷ / ₈	700	230 60.8981.0020	
250	9 ¹³ / ₁₆	200	7 ⁷ / ₈	700	120 57.0174.9990	



NEUTRAL

Elektroheizung, Heating element, Chauffage électrique
 für / for / pour „Induction Plus“
 selbstregelnd, self-regulating, réglage automatique

Länge length		Breite width		Heizleistung heating efficiency	Netzspannung line voltage	
mm	in.	mm	in.	Watt	Volt	
250	9 ¹³ / ₁₆	200	7 ⁷ / ₈	220	140/250 57.0024.9990	
250	9 ¹³ / ₁₆	200	7 ⁷ / ₈	220	120 57.0173.9990	



NEUTRAL

Brennerhalter, Burner holder, Porte-brûleur
 für alle Gestelle GN 1/1 , „Induction Plus“,
 for all stands GN 1/1 , „Induction Plus“,
 pour tous les stands (supports) GN 1/1 , „Induction Plus“

Länge length		Breite width		Höhe height		
mm	in.	mm	in.	mm	in.	
258	10 ³ / ₁₆	200	7 ⁷ / ₈	90	3 ⁹ / ₁₆	12.2171.0000



NEUTRAL

CHAFING DISH



Chafing Dish GN 1/1

mit ganz rollender Haube, with full roll top cover, avec couvercle roulant

für Brennstoff oder Elektroheizung, mit Brennerhalter, ohne Einsätze, ohne Elektroheizung, Zubehör im Bereich Chafing Dish Zubehör,
for burner or electrical heating, with burner holder, without inserts, without electrical heating, accessory in the category chafing dish accessory,
pour brûleur ou chauffage électrique, avec Porte-Brûleur, sans récipient, sans chauffage électrique, accessoire dans le domaine du Chafing Dish accessoire

Länge length		Breite width		Höhe height		18/10	versilbert silver-plated
mm	in.	mm	in.	mm	in.		
690	27 ⁹ / ₁₆	385	15 ⁹ / ₁₆	460	18 ¹ / ₈	12.3494.0320	15.3494.0320



EXCLUSIVE

Chafing Dish Ø 30 cm

rund mit ganz rollender Haube, round with full roll top cover,
rond avec couvercle roulant

für Brennstoff oder Elektroheizung, mit Brennerhalter, mit Einsätze, ohne Elektroheizung, Zubehör im Bereich Chafing Dish Zubehör,
for burner or electrical heating, with burner holder, with inserts, without electrical heating, accessory in the category chafing dish accessory,
pour brûleur ou chauffage électrique, avec Porte-Brûleur, avec récipient, sans chauffage électrique, accessoire dans le domaine du Chafing Dish accessoire

Breite width		Höhe height		18/10	versilbert silver-plated
mm	in.	mm	in.		
450	17 ¹¹ / ₁₆	490	19 ⁹ / ₁₆	12.3493.1320	15.3493.1320



EXCLUSIVE

Chafing Dish Ø 40 cm

rund mit ganz rollender Haube, round with full roll top cover,
rond avec couvercle roulant

für Brennstoff oder Elektroheizung, mit Brennerhalter, mit Einsätze, ohne Elektroheizung, Zubehör im Bereich Chafing Dish Zubehör,
for burner or electrical heating, with burner holder, with inserts, without electrical heating, accessory in the category chafing dish accessory,
pour brûleur ou chauffage électrique, avec Porte-Brûleur, avec récipient, sans chauffage électrique, accessoire dans le domaine du Chafing Dish accessoire

Breite width		Höhe height		18/10	versilbert silver-plated
mm	in.	mm	in.		
545	21 ⁷ / ₁₆	600	23 ⁵ / ₈	12.3493.2320	15.3493.2320



EXCLUSIVE

CHAFING DISH

Chafing Dish Ø 24 cm

rund mit ganz rollender Haube, round with full roll top cover,
avec couvercle roulant

für Brennstoff, mit Einsätze, for burner, with inserts,
pour brûleur, avec récipient

Breite width		Höhe height		18/10 18/10	versilbert silver-plated
mm	in.	mm	in.		
325	12 ¹³ / ₁₆	350	13 ³ / ₄	12.3493.3010	15.3493.3010



EXCLUSIVE

Chafing Dish GN 1/1

mit ganz rollender Haube, stapelbar, with full roll top cover, stackable,
avec couvercle roulant, empilable

für Brennstoff oder Elektroheizung, mit Brennerhalter, ohne Einsätze, ohne Elektro-
heizung, Zubehör im Bereich Chafing Dish Zubehör,
for burner or electrical heating, with burner holder, without inserts, without electrical
heating, accessory in the category chafing dish accessory,
pour brûleur ou chauffage électrique, avec Porte-Brûleur, sans récipient, sans
chauffage électrique, accessoire dans le domaine du Chafing Dish accessoire

Länge length		Breite width		Höhe height		18/10 18/10	versilbert silver-plated
mm	in.	mm	in.	mm	in.		
700	27 ⁹ / ₁₆	400	15 ³ / ₄	470	18 ¹ / ₂	12.4094.0320	13.4594.0320



EXCELLENT

Chafing Dish Ø 30 cm

mit ganz rollender Haube, stapelbar, with full roll top cover, stackable,
avec couvercle roulant, empilable

für Brennstoff oder Elektroheizung, mit Brennerhalter, mit Einsätze, ohne Elektro-
heizung, Zubehör im Bereich Chafing Dish Zubehör,
for burner or electrical heating, with burner holder, with inserts, without electrical
heating, accessory in the category chafing dish accessory,
pour brûleur ou chauffage électrique, avec Porte-Brûleur, avec récipient, sans
chauffage électrique, accessoire dans le domaine du Chafing Dish accessoire

Breite width		Höhe height		18/10 18/10	versilbert silver-plated
mm	in.	mm	in.		
450	17 ¹¹ / ₁₆	480	18 ⁷ / ₈	12.4093.1320	13.4593.1320



EXCELLENT

Chafing Dish Ø 40 cm

mit ganz rollender Haube, stapelbar, with full roll top cover, stackable,
avec couvercle roulant, empilable

für Brennstoff oder Elektroheizung, mit Brennerhalter, mit Einsätze, ohne Elektro-
heizung, Zubehör im Bereich Chafing Dish Zubehör,

for burner or electrical heating, with burner holder, with inserts, without electrical
heating, accessory in the category chafing dish accessory,

pour brûleur ou chauffage électrique, avec Porte-Brûleur, avec récipient, sans
chauffage électrique, accessoire dans le domaine du Chafing Dish accessoire

Breite width		Höhe height		18/10	versilbert silver-plated
mm	in.	mm	in.	18/10	
555	21 ⁷ / ₈	600	23 ⁵ / ₈	12.4093.2320	13.4593.2320



EXCELLENT

Chafing Dish GN 1/1

mit ganz rollender Haube, with full roll top cover, avec couvercle roulant

für Brennstoff oder Elektroheizung, mit Brennerhalter, ohne Einsätze, ohne Elektro-
heizung, Zubehör im Bereich Chafing Dish Zubehör,

for burner or electrical heating, with burner holder, without inserts, without electrical
heating, accessory in the category chafing dish accessory,

pour brûleur ou chauffage électrique, avec Porte-Brûleur, sans récipient, sans
chauffage électrique, accessoire dans le domaine du Chafing Dish accessoire

Länge length		Breite width		Höhe height		18/10	versilbert silver-plated
mm	in.	mm	in.	mm	in.	18/10	
710	27 ¹⁵ / ₁₆	390	15 ³ / ₈	445	17 ¹ / ₂	12.4895.0320	13.4895.0320



PROFILE

Chafing Dish Ø 30 cm

mit ganz rollender Haube, with full roll top cover, avec couvercle roulant

für Brennstoff oder Elektroheizung, mit Brennerhalter, mit Einsätze, ohne Elektro-
heizung, Zubehör im Bereich Chafing Dish Zubehör,

for burner or electrical heating, with burner holder, with inserts, without electrical
heating, accessory in the category chafing dish accessory,

pour brûleur ou chauffage électrique, avec Porte-Brûleur, avec récipient, sans
chauffage électrique, accessoire dans le domaine du Chafing Dish accessoire

Länge length		Breite width		Höhe height		18/10	versilbert silver-plated
mm	in.	mm	in.	mm	in.	18/10	
410	16 ¹ / ₈	450	17 ¹¹ / ₁₆	475	18 ¹¹ / ₁₆	12.4896.1320	13.4896.1320



PROFILE

CHAFING DISH

Chafing Dish Ø 40 cm

mit ganz rollender Haube, with full roll top cover, avec couvercle roulant

für Brennstoff oder Elektroheizung, mit Brennerhalter, mit Einsätze, ohne Elektroheizung, Zubehör im Bereich Chafing Dish Zubehör,
for burner or electrical heating, with burner holder, with inserts, without electrical heating, accessory in the category chafing dish accessory,
pour brûleur ou chauffage électrique, avec Porte-Brûleur, avec récipient, sans chauffage électrique, accessoire dans le domaine du Chafing Dish accessoire

Länge length		Breite width		Höhe height		18/10	versilbert silver-plated
mm	in.	mm	in.	mm	in.		
500	19 ¹¹ / ₁₆	540	21 ¹ / ₄	580	22 ¹³ / ₁₆	12.4896.2320	13.4896.2320



PROFILE

Chafing Dish GN 1/1

mit ganz rollender Haube, with full roll top cover, avec couvercle roulant

für Brennstoff oder Elektroheizung, mit Brennerhalter, ohne Einsätze, ohne Elektroheizung, Zubehör im Bereich Chafing Dish Zubehör,
for burner or electrical heating, with burner holder, without inserts, without electrical heating, accessory in the category chafing dish accessory,
pour brûleur ou chauffage électrique, avec Porte-Brûleur, sans récipient, sans chauffage électrique, accessoire dans le domaine du Chafing Dish accessoire

Länge length		Breite width		Höhe height		18/10
mm	in.	mm	in.	mm	in.	18/10
710	27 ¹⁵ / ₁₆	390	15 ³ / ₈	445	17 ¹ / ₂	12.5294.0320



ARTE

Chafing Dish Ø 30 cm

mit ganz rollender Haube, with full roll top cover, avec couvercle roulant

 für Brennstoff oder Elektroheizung, mit Brennerhalter, mit Einsätze, ohne Elektro-
 heizung, Zubehör im Bereich Chafing Dish Zubehör,

 for burner or electrical heating, with burner holder, with inserts, without electrical
 heating, accessory in the category chafing dish accessory,

 pour brûleur ou chauffage électrique, avec Porte-Brûleur, avec récipient, sans
 chauffage électrique, accessoire dans le domaine du Chafing Dish accessoire

Länge length		Breite width		Höhe height		18/10 18/10
mm	in.	mm	in.	mm	in.	
410	16 ¹ / ₈	450	17 ¹¹ / ₁₆	475	18 ¹¹ / ₁₆	12.5293.1320

 ARTE

Chafing Dish Ø 40 cm

mit ganz rollender Haube, with full roll top cover, avec couvercle roulant

 für Brennstoff oder Elektroheizung, mit Brennerhalter, mit Einsätze, ohne Elektro-
 heizung, Zubehör im Bereich Chafing Dish Zubehör,

 for burner or electrical heating, with burner holder, with inserts, without electrical
 heating, accessory in the category chafing dish accessory,

 pour brûleur ou chauffage électrique, avec Porte-Brûleur, avec récipient, sans
 chauffage électrique, accessoire dans le domaine du Chafing Dish accessoire

Länge length		Breite width		Höhe height		18/10 18/10
mm	in.	mm	in.	mm	in.	
500	19 ¹¹ / ₁₆	540	21 ¹ / ₄	580	22 ¹³ / ₁₆	12.5293.2320

 ARTE

CHAFING DISH

Chafing Dish GN 1/1

Thekeneinbau, to be built into counter, pour montage en comptoir

für Elektroheizung, ohne Einsätze, ohne Elektroheizung, Zubehör im Bereich Chafing Dish Zubehör,

for electrical heating, without inserts, without electrical heating, accessory in the category chafing dish accessory,

pour chauffage électrique, sans récipient, sans chauffage électrique, accessoire dans le domaine du Chafing Dish accessoire

Außenmaß outer dimension		Höhe height		18/10 18/10
mm	in.	mm	in.	
649 x 468	25 ⁹ / ₁₆ x 18 ⁷ / ₁₆	170	6 ¹¹ / ₁₆	12.2089.0320



Ausschnittmaß Draufsicht
Cut-out dimension, top view
Côte de coupe, vue de dessus

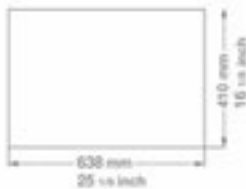

Ausschnittmaß Seitenansicht
Cut-out dimension, side view
Côte de coupe, vue de côté



NEUTRAL

Chafing Dish Ø 40 cm

Thekeneinbau rund, to be built into counter round, pour montage en comptoir rond

für Elektroheizung, mit Einsätze, ohne Elektroheizung, Zubehör im Bereich Chafing Dish Zubehör,

for electrical heating, with inserts, without electrical heating, accessory in the category chafing dish accessory,

pour chauffage électrique, avec récipient, sans chauffage électrique, accessoire dans le domaine du Chafing Dish accessoire

Außenmaß outer dimension		Höhe height		18/10 18/10
mm	in.	mm	in.	
Ø580	Ø22 ¹³ / ₁₆	230	9 ¹ / ₁₆	12.2090.2221



Ausschnittmaß Theke Draufsicht
Cut-out dimension Counter, top view
Côte de coupe Comptoir, vue de dessus



Ausschnittmaß Seitenansicht
Cut-out dimension, side view
Côte de coupe, vue de côté



NEUTRAL

Chafing Dish GN 1/1

mit abnehmbarer Haube, with removable cover, avec couvercle démontable

 für Brennstoff oder Elektroheizung, mit Brennerhalter, ohne Einsätze, ohne Elektroheizung, Zubehör im Bereich Chafing Dish Zubehör,
 for burner or electrical heating, with burner holder, without inserts, without electrical heating, accessory in the category chafing dish accessory,
 pour brûleur ou chauffage électrique, avec Porte-brûleur, sans récipient, sans chauffage électrique, accessoire dans le domaine du Chafing Dish accessoire

Länge length		Breite width		Höhe height		18/10 18/10
mm	in.	mm	in.	mm	in.	
640	25 ³ / ₁₆	348	13 ¹¹ / ₁₆	321	12 ⁵ / ₈	57.0052.6040

Einsatz für Chafing Dish, Insert for Chafing Dish, Récipient pour Chafing Dish
 Gastronorm 1/1

Inhalt cap.		Länge length		Breite width		Höhe height		18/10 18/10
Ltr.	oz.	mm	in.	mm	in.	mm	in.	
9,50	335	530	20 ⁷ / ₈	325	12 ¹³ / ₁₆	65	2 ⁹ / ₁₆	57.0053.6040

NEUTRAL

Chafing Dish GN 1/1

mit halbrollender Haube, with half roll top cover, avec couvercle demi-roulant

 für Brennstoff oder Elektroheizung, mit Brennerhalter, ohne Einsätze, ohne Elektroheizung, Zubehör im Bereich Chafing Dish Zubehör,
 for burner or electrical heating, with burner holder, without inserts, without electrical heating, accessory in the category chafing dish accessory,
 pour brûleur ou chauffage électrique, avec Porte-brûleur, sans récipient, sans chauffage électrique, accessoire dans le domaine du Chafing Dish accessoire

Länge length		Breite width		Höhe height		18/10 18/10
mm	in.	mm	in.	mm	in.	
640	25 ³ / ₁₆	360	14 ³ / ₁₆	430	16 ¹⁵ / ₁₆	57.0057.6040

Einsatz für Chafing Dish, Insert for Chafing Dish, Récipient pour Chafing Dish
 Gastronorm 1/1

Inhalt cap.		Länge length		Breite width		Höhe height		18/10 18/10
Ltr.	oz.	mm	in.	mm	in.	mm	in.	
9,50	335	530	20 ⁷ / ₈	325	12 ¹³ / ₁₆	65	2 ⁹ / ₁₆	57.0053.6040

NEUTRAL

Suppenstation, Soup Station, Station potage

komplett, complete, complète

 für Brennstoff oder Elektroheizung, mit Brennerhalter, ohne Elektroheizung, Zubehör im Bereich Chafing Dish Zubehör,
 for burner or electrical heating, with burner holder, without electrical heating, accessory in the category chafing dish accessory,
 pour brûleur ou chauffage électrique, avec Porte-brûleur, sans chauffage électrique, accessoire dans le domaine du Chafing Dish accessoire

Inhalt cap.		Länge length		Breite width		Höhe height		18/10 18/10
Ltr.	oz.	mm	in.	mm	in.	mm	in.	
2 x 4,50	2 x 158	640	25 ³ / ₁₆	345	13 ⁹ / ₁₆	380	14 ¹⁵ / ₁₆	57.0059.6040

NEUTRAL



CHAFING DISH



Chafing Dish GN 1/1
mit Klapphaube, with Flap rolltop cover, avec capot valvaire

für Brennstoff oder Elektroheizung, ohne Einsätze, ohne Elektroheizung, Zubehör im Bereich Chafing Dish Zubehör,
for burner or electrical heating, without inserts, without electrical heating, accessory in the category chafing dish accessory,
pour brûleur ou chauffage électrique, sans récipient, sans chauffage électrique, accessoire dans le domaine du Chafing Dish accessoire

Länge length		Breite width		Höhe height		18/10 18/10
mm	in.	mm	in.	mm	in.	
660	26	380	14 ¹⁵ / ₁₆	380	14 ¹⁵ / ₁₆	57.0040.6040

Klapphaube, Flap rolltop cover, Capot valvaire
für Chafing Dish GN 1/1, for Chafing Dish GN 1/1, pour Chafing Dish GN 1/1

Länge length		Breite width		Höhe height		18/10 18/10
mm	in.	mm	in.	mm	in.	
545	21 ⁷ / ₁₆	370	14 ⁹ / ₁₆	180	7 ¹ / ₁₆	57.0042.6040

NEUTRAL



Suppenmarmite, Soup marmite, Marmite potage

für Brennstoff oder Elektroheizung, ohne Elektroheizung, Zubehör im Bereich Chafing Dish Zubehör,
for burner or electrical heating, without electrical heating, accessory in the category chafing dish accessory,
pour brûleur ou chauffage électrique, sans chauffage électrique, accessoire dans le domaine du Chafing Dish accessoire

Inhalt cap.		Höhe height		Ø-Außen Ø-outer		18/10 18/10
Ltr.	oz.	mm	in.	mm	in.	
4,50	158	390	15 ³ / ₈	355	14	12.5599.1120
9,00	317	410	16 ¹ / ₈	355	14	12.5599.2120

NEUTRAL



Suppenstation, Soup Station, Station potage
für Chafing Dish Ø 30 cm, rund, for Chafing Dish Ø 30 cm, round,
pour Chafing Dish rond, Ø 30 cm

Inhalt cap.		Ø-Außen Ø-outer		18/10 18/10
Ltr.	oz.	mm	in.	
4,50	158	345	13 ⁹ / ₁₆	12.2073.0000
9,00	317	345	13 ⁹ / ₁₆	60.8873.0000

NEUTRAL

Suppenstation, Soup Station, Station potage
 für Chafing Dish GN 1/1, for Chafing Dish GN 1/1, pour Chafing Dish GN 1/1

Inhalt cap.		Länge length		Breite width		18/10 18/10	
Ltr.	oz.	mm	in.	mm	in.		
2 x 4,50	2 x 158	530	20 ⁷ / ₈	325	12 ¹³ / ₁₆	60.8872.0000	



NEUTRAL

Chafing Dish
 rund für Sauce, round for sauce, rond pour sauce

Inhalt cap.		Höhe height		Ø-Außen Ø-outer		18/10 18/10		versilbert silver-plated	
Ltr.	oz.	mm	in.	mm	in.				
1,00	35	255	10 ¹ / ₁₆	171	6 ³ / ₄	12.2297.0000	15.2297.0000		



NEUTRAL

Chafing Dish Haube GN 1/1, Chafing Dish cover GN 1/1,
 Couvercle pour Chafing Dish GN 1/1
 halbrollend, half-rolling, demi-roulant

Länge length		Breite width		Höhe height		18/10 18/10	
mm	in.	mm	in.	mm	in.		
538	21 ³ / ₁₆	338	9 ³ / ₈	214	8 ⁷ / ₁₆	57.0058.6040	



NEUTRAL

Einsatz für Chafing Dish, Insert for Chafing Dish, Récipient pour Chafing Dish
Gastronorm 1/1

Inhalt cap.		Länge length		Breite width		Höhe height		18/10 18/10
Ltr.	oz.	mm	in.	mm	in.	mm	in.	
9,50	335	530	20 ⁷ / ₈	325	12 ¹³ / ₁₆	65	2 ⁹ / ₁₆	60.8824.0110
14,00	493	530	20 ⁷ / ₈	325	12 ¹³ / ₁₆	100	3 ¹⁵ / ₁₆	60.8825.0110



NEUTRAL

Einsatz für Chafing Dish, Insert for Chafing Dish, Récipient pour Chafing Dish
Gastronorm 1/2

Inhalt cap.		Länge length		Breite width		Höhe height		18/10 18/10
Ltr.	oz.	mm	in.	mm	in.	mm	in.	
3,75	132	265	10 ⁷ / ₁₆	325	12 ¹³ / ₁₆	65	2 ⁹ / ₁₆	60.8824.0120
6,50	229	265	10 ⁷ / ₁₆	325	12 ¹³ / ₁₆	100	3 ¹⁵ / ₁₆	60.8825.0120



NEUTRAL

Einsatz für Chafing Dish, Insert for Chafing Dish, Récipient pour Chafing Dish
Gastronorm 2/3

Inhalt cap.		Länge length		Breite width		Höhe height		18/10 18/10
Ltr.	oz.	mm	in.	mm	in.	mm	in.	
5,50	194	354	13 ¹⁵ / ₁₆	325	12 ¹³ / ₁₆	65	2 ⁹ / ₁₆	60.8824.0230
9,00	317	354	13 ¹⁵ / ₁₆	325	12 ¹³ / ₁₆	100	3 ¹⁵ / ₁₆	60.8825.0230



NEUTRAL

Einsatz für Chafing Dish, Insert for Chafing Dish, Récipient pour Chafing Dish
Gastronorm 1/3

Inhalt cap.		Länge length		Breite width		Höhe height		18/10 18/10
Ltr.	oz.	mm	in.	mm	in.	mm	in.	
2,50	88	176	6 ¹⁵ / ₁₆	325	12 ¹³ / ₁₆	65	2 ⁹ / ₁₆	60.8824.0130
3,75	132	176	6 ¹⁵ / ₁₆	325	12 ¹³ / ₁₆	100	3 ¹⁵ / ₁₆	60.8825.0130



NEUTRAL

Porzellan-Einsatz, Porcelain insert, Bac en porcelaine
Gastronorm 1/1

Inhalt cap.		Länge length		Breite width		Höhe height		Porzellan porcelain
Ltr.	oz.	mm	in.	mm	in.	mm	in.	
7,3	257	530	20 ⁷ / ₈	325	12 ¹³ / ₁₆	20	¹³ / ₁₆	57.0071.9800
		530	20 ⁷ / ₈	325	12 ¹³ / ₁₆	65	2 ⁹ / ₁₆	50.8366.0110



NEUTRAL

Porzellan-Einsatz, Porcelain insert, Bac en porcelaine
Gastronorm 1/2

Inhalt cap.		Länge length		Breite width		Höhe height		Porzellan porcelain
Ltr.	oz.	mm	in.	mm	in.	mm	in.	
3,30	116	265	10 ⁷ / ₁₆	325	12 ¹³ / ₁₆	65	2 ⁹ / ₁₆	50.8366.0120



NEUTRAL

Porzellan-Einsatz, Porcelain insert, Bac en porcelaine
Gastronorm 2/3

Inhalt cap.		Länge length		Breite width		Höhe height		Porzellan porcelain
Ltr.	oz.	mm	in.	mm	in.	mm	in.	
4,65	164	354	13 ¹⁵ / ₁₆	325	12 ¹³ / ₁₆	65	2 ⁹ / ₁₆	50.8366.0230



NEUTRAL

Porzellan-Einsatz, Porcelain insert, Bac en porcelaine
Gastronorm 1/3

Inhalt cap.		Länge length		Breite width		Höhe height		Porzellan porcelain
Ltr.	oz.	mm	in.	mm	in.	mm	in.	
1,9	67	175	6 ⁷ / ₈	325	12 ¹³ / ₁₆	65	2 ⁹ / ₁₆	50.8366.0130



NEUTRAL



Porzellan-Einsatz, Porcelain insert, Bac en porcelaine
Gastronorm 2/4

Inhalt cap.		Länge length		Breite width		Höhe height		Porzellan porcelain
Ltr.	oz.	mm	in.	mm	in.	mm	in.	
0,7	24,5	530	20 ⁷ / ₈	160	6 ⁵ / ₁₆	20	¹³ / ₁₆	57.0072.9800
2,5	87,5	530	20 ⁷ / ₈	160	6 ⁵ / ₁₆	65	2 ⁹ / ₁₆	57.0073.9800

NEUTRAL

Porzellan-Einsatz, Porcelain insert, Bac en porcelaine
für Chafing Dish, for Chafing Dish, pour Chafing Dish

Inhalt cap.		Höhe height		Ø	Ø-Außen	Ø-Außen	Porzellan porcelain
Ltr.	oz.	mm	in.	mm	mm	in.	
3,00	106	70	2 ¹ / ₈	Ø 30 cm	335	13 ⁹ / ₁₆	60.8874.3000



NEUTRAL

Porzellan-Einsatz, Porcelain insert, Bac en porcelaine
für Chafing Dish, 2-tlg., for Chafing Dish, 2-part, pour Chafing Dish, 2 parties

Inhalt cap.		Höhe height		Ø	Ø-Außen	Ø-Außen	Porzellan porcelain
Ltr.	oz.	mm	in.	mm	mm	in.	
2,60	92	70	2 ¹ / ₈	Ø 30 cm	335	13 ⁹ / ₁₆	60.8879.3000



NEUTRAL

Einsatz für Chafing Dish, Insert for Chafing Dish, Récipient pour Chafing Dish
rund, round, rond

Inhalt cap.		Höhe height		Ø	Ø-Außen	Ø-Außen	18/10
Ltr.	oz.	mm	in.	mm	mm	in.	18/10
1,50	53	50	1 ¹⁵ / ₁₆	Ø 24 cm	260	10 ¹ / ₄	12.2054.2400
5,00	176	87	3 ³ / ₁₆	Ø 30 cm	335	13 ⁹ / ₁₆	60.8915.3010
9,00	317	109	4 ⁵ / ₁₆	Ø 40 cm	418	16 ⁷ / ₁₆	60.8915.4000



NEUTRAL

Einsatz für Chafing Dish, Insert for Chafing Dish, Récipient pour Chafing Dish
 rund, round, rond

Inhalt cap.		Höhe height		Ø	Ø-Außen Ø-outer	Ø-Außen Ø-outer	18/10 18/10
Ltr.	oz.	mm	in.	mm	mm	in.	
5,00	176	68	2 ¹¹ / ₁₆	Ø 40 cm	416	16 ³ / ₈	60.8917.4000



NEUTRAL

Steg, Strut, Traverse

Länge length				18/10 18/10
mm	in.			
325	12 ¹³ / ₁₆			60.8853.3250



NEUTRAL

Brennerhalter, Burner holder, Porte-brûleur
 für alle Gestelle GN 1/1, „Induction Plus“,
 for all stands GN 1/1, „Induction Plus“,
 pour tous les stands (supports) GN 1/1, „Induction Plus“

Länge length		Breite width		Höhe height		18/10 18/10
mm	in.	mm	in.	mm	in.	
258	10 ³ / ₁₆	200	7 ⁷ / ₈	90	3 ⁹ / ₁₆	12.2171.0000



NEUTRAL

Brennerhalter, Burner holder, Porte-brûleur
 für Chafing Dish Ø 30 cm, Ø 40 cm, rund, for Chafing Dish Ø 30 cm, Ø 40 cm,
 round,
 pour Chafing Dish rond, Ø 30 cm et Ø 40 cm

Länge length		Breite width		Höhe height		18/10 18/10
mm	in.	mm	in.	mm	in.	
109	4 ⁵ / ₁₆	200	7 ⁷ / ₈	87	3 ⁷ / ₁₆	12.2171.1000

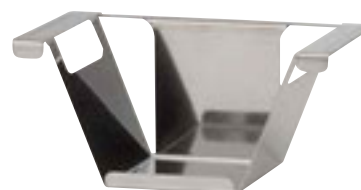

NEUTRAL

Brennerdose, Burner tin, Porte brûleur
für Brennpaste, for dry fuel burner, pour brûleur à gel

Ø-Außen		18/10
Ø-outer		18/10
mm	in.	
94	3 ¹¹ / ₁₆	60.8884.0000



NEUTRAL

Elektroheizung, Heating element, Chauffage électrique
für / for / pour Chafing Dish Ø 30 cm
manuell regelbar, manually adjustable, manuellement réglable

Länge length		Breite width		Heizleistung heating efficiency	Netzspannung line voltage	
mm	in.	mm	in.	Watt	Volt	
200	7 ⁷ / ₈	200	7 ⁷ / ₈	550	230	60.8981.0030



NEUTRAL

Elektroheizung regelbar, Heating element adjustable, Chauffage électrique réglable
für / for / pour „Induction Plus“, Chafing Dish GN 1/1, Ø 40 cm
manuell regelbar, manually adjustable, manuellement réglable

Länge length		Breite width		Heizleistung heating efficiency	Netzspannung line voltage	
mm	in.	mm	in.	Watt	Volt	
250	9 ¹³ / ₁₆	200	7 ⁷ / ₈	700	230	60.8981.0020
250	9 ¹³ / ₁₆	200	7 ⁷ / ₈	700	120	57.0174.9990



NEUTRAL

Elektroheizung, Heating element, Chauffage électrique
für / for / pour Chafing Dish Ø 30 cm
selbstregelnd, self-regulating, réglage automatique

Länge length		Breite width		Heizleistung heating efficiency	Netzspannung line voltage	
mm	in.	mm	in.	Watt	Volt	
200	7 ⁷ / ₈	200	7 ⁷ / ₈	270	140/250	60.8880.0030
200	7 ⁷ / ₈	200	7 ⁷ / ₈	230	110/120	60.8980.0030



NEUTRAL

Elektroheizung, Heating element, Chauffage électrique
für / for / pour Chafing Dish GN 1/1, Ø 40 cm

Länge length		Breite width		Heizleistung heating efficiency	Netzspannung line voltage	
mm	in.	mm	in.	Watt	Volt	
250	9 ¹³ / ₁₆	200	7 ⁷ / ₈	600	230	57.0067.9990
250	9 ¹³ / ₁₆	200	7 ⁷ / ₈	600	120	60.8980.0040



NEUTRAL

Elektroheizung, Heating element, Chauffage électrique
für / for / pour „Induction Plus“

selbstregelnd, self-regulating, réglage automatique

Länge length		Breite width		Heizleistung heating efficiency	Netzspannung line voltage	
mm	in.	mm	in.	Watt	Volt	
250	9 ¹³ / ₁₆	200	7 ⁷ / ₈	220	140/250	57.0024.9990
250	9 ¹³ / ₁₆	200	7 ⁷ / ₈	220	120	57.0173.9990



NEUTRAL

Elektroheizung, Heating element, Chauffage électrique
für / for / pour Chafing Dish 57.0052.6040, 57.0057.6040, 57.0059.6040

selbstregelnd, self-regulating, réglage automatique

Länge length		Breite width		Heizleistung heating efficiency	Netzspannung line voltage	
mm	in.	mm	in.	Watt	Volt	
250	9 ¹³ / ₁₆	200	7 ⁷ / ₈	600	230	60.8883.0040



NEUTRAL

BUFFET



Servierblech, Serving tray, Plateau de service
oval, ovale

Länge length		Breite width		18/10	versilbert
mm	in.	mm	in.	18/10	silver-plated
221	8 ¹¹ / ₁₆	156	6 ¹ / ₈	12.2032.2300	13.3032.2300
270	10 ⁹ / ₈	200	7 ⁷ / ₈	12.2032.2650	13.3032.2650
323	12 ¹ / ₁₆	240	9 ⁷ / ₁₆	12.2032.3200	13.3032.3200

NEUTRAL



Servierblech, Serving tray, Plateau de service
rund, round, rond

Ø-Außen Ø-outer		18/10	versilbert
mm	in.	18/10	silver-plated
269	10 ⁹ / ₁₆	12.2037.2600	13.3037.2600
327	12 ⁷ / ₈	12.2037.3000	13.3037.3000
369	14 ¹ / ₂	12.2037.3600	13.3037.3600
400	15 ³ / ₄	12.2037.4000	13.3037.4000

NEUTRAL



Servierblech, Serving tray, Plateau de service

Länge length		Breite width		18/10	versilbert
mm	in.	mm	in.	18/10	silver-plated
305	12	254	10	12.2166.3050	13.3166.3050
384	15 ¹ / ₈	290	11 ⁷ / ₁₆	12.2166.3840	13.3166.3840
458	18 ¹ / ₁₆	333	13 ¹ / ₈	12.2166.4580	13.3166.4580

NEUTRAL



Ausstellplatte, Banquet tray, Plateau d'exposition
Gastronorm ²/₁

Länge length		Breite width		18/10	versilbert
mm	in.	mm	in.	18/10	silver-plated
650	25 ⁹ / ₁₆	530	20 ⁷ / ₈	12.2056.6500	13.3056.6500

NEUTRAL

Ausstellplatte, Banquet tray, Plateau d'exposition
 Gastronorm 1/1

Länge length		Breite width		18/10 18/10	versilbert silver-plated
mm	in.	mm	in.		
530	20 ⁷ / ₈	325	12 ¹³ / ₁₆	12.2056.5300	13.3056.5300

 NEUTRAL

Ausstellplatte, Banquet tray, Plateau d'exposition
 Gastronorm 1/2

Länge length		Breite width		18/10 18/10	versilbert silver-plated
mm	in.	mm	in.		
325	12 ¹³ / ₁₆	265	10 ⁷ / ₁₆	12.2056.3250	13.3056.3250

 NEUTRAL

Ausstellplatte, Banquet tray, Plateau d'exposition
 rechteckig, rectangular, rectangulaire

Länge length		Breite width		18/10 18/10	versilbert silver-plated
mm	in.	mm	in.		
526	20 ¹¹ / ₁₆	408	16 ¹ / ₁₆	12.2058.5260	13.3058.5260

 NEUTRAL

Ausstellplatte, Banquet tray, Plateau d'exposition
 oval, ovale

Länge length		Breite width		18/10 18/10	versilbert silver-plated
mm	in.	mm	in.		
516	20 ⁹ / ₁₆	392	15 ⁷ / ₁₆	12.2157.5200	13.3157.5200

 NEUTRAL

BUFFET

Ausstellplatte, Banquet tray, Plateau d'exposition rund, round, rond



Ø-Außen Ø-outer		18/10	versilbert silver-plated
mm	in.		
425	16 ³ / ₄	12.2060.4200	13.3060.4200
500	19 ¹ / ₁₆	12.2060.5000	13.3060.5000

NEUTRAL

Ausstellplatte, Banquet tray, Plateau d'exposition rund, round, rond



Länge ohne Griffe, Length without handles, Longueur sans anses

Ø-Außen Ø-outer		18/10	versilbert silver-plated
mm	in.		
425	16 ³ / ₄	12.4860.4200	15.4860.4200
500	19 ¹ / ₁₆	12.4860.5000	15.4860.5000

PROFILE

Ausstellplatte, Banquet tray, Plateau d'exposition rechteckig, rectangular, rectangulaire



Länge ohne Griffe, Length without handles, Longueur sans anses

Länge length		Breite width		18/10	versilbert silver-plated
mm	in.	mm	in.		
530	20 ⁷ / ₈	325	12 ¹³ / ₁₆	12.4058.5300	15.4558.5300
650	25 ⁹ / ₁₆	530	20 ⁷ / ₈	12.4058.6500	15.4558.6500
780	30 ¹ / ₁₆	515	20 ¹ / ₄	12.4058.7500	15.4558.7500

EXCELLENT

Ausstellplatte, Banquet tray, Plateau d'exposition rechteckig, rectangular, rectangulaire



Länge ohne Griffe, Length without handles, Longueur sans anses

Länge length		Breite width		18/10	versilbert silver-plated
mm	in.	mm	in.		
650	25 ⁹ / ₁₆	530	20 ⁷ / ₈	12.4858.6500	15.4858.6500

PROFILE

Plexiglashaube, Plexiglass hood, Cloche en verre plexi

Höhe height		Ø-Außen Ø-outer		Kunststoff plastics
mm	in.	mm	in.	
216	8½	348	13 ¹¹ / ₁₆	60.8989.3400



NEUTRAL



Plattenständer tief, Tray stand low, Plaque stands profond
 kombinierbar mit Servierplatte GN 1/1 Porzellan 57.0071.9800, Edelstahl 18/10 12.2056.5300, Kühlakku 57.0070.9990 und Abdeckhaube 57.0170.9990, combinable with serving plate GN 1/1 porcelain 57.0071.9800, stainless steel 18/10 12.2056.5300, ice pack 57.0070.9990, cover for trays 57.0170.9990, combinable avec plateau de service GN 1/1 porcelaine 57.0071.9800, acier inoxydable 18/10 12.2056.5300, Element de refrigeration 57.0070.9990, Cloche pour plateaux 57.0170.9990

stapelbar, stackable, empilable

Länge length		Breite width		Höhe height		18/10 18/10
mm	in.	mm	in.	mm	in.	
510	20 ¹ / ₁₆	300	11 ¹³ / ₁₆	125	4 ¹⁵ / ₁₆	57.0065.6040

NEUTRAL



Plattenständer hoch, Tray stand high, Plaque stands haut
 kombinierbar mit Servierplatte GN 1/1 Porzellan 57.0071.9800, Edelstahl 18/10 12.2056.5300, Kühlakku 57.0070.9990 und Abdeckhaube 57.0170.9990, combinable with serving plate GN 1/1 porcelain 57.0071.9800, stainless steel 18/10 12.2056.5300, ice pack 57.0070.9990, cover for trays 57.0170.9990, combinable avec plateau de service GN 1/1 porcelaine 57.0071.9800, acier inoxydable 18/10 12.2056.5300, Element de refrigeration 57.0070.9990, Cloche pour plateaux 57.0170.9990

stapelbar, stackable, empilable

Länge length		Breite width		Höhe height		18/10 18/10
mm	in.	mm	in.	mm	in.	
510	20 ¹ / ₁₆	300	11 ¹³ / ₁₆	185	7 ⁵ / ₁₆	57.0066.6040

NEUTRAL



Kühlakku, Ice pack, Element de refrigeration
 Gastronorm 1/2

Länge length		Breite width		Höhe height		Kunststoff plastics
mm	in.	mm	in.	mm	in.	
255	10 ¹ / ₁₆	203	8	32	1 ¹ / ₄	57.0070.9990

NEUTRAL

Porzellan-Einsatz, Porcelain insert, Bac en porcelaine
Gastronorm 1/1

Länge length		Breite width		Höhe height		Porzellan porcelain
mm	in.	mm	in.	mm	in.	
530	20 ⁷ / ₈	325	12 ¹³ / ₁₆	20	¹³ / ₁₆	57.0071.9800



NEUTRAL

Ausstellplatte, Banquet tray, Plateau d'exposition
Gastronorm 1/1

Länge length		Breite width		18/10 18/10	versilbert silver-plated
mm	in.	mm	in.		
530	20 ⁷ / ₈	325	12 ¹³ / ₁₆	12.2056.5300	13.3056.5300



NEUTRAL

Abdeckhaube , Cover for trays, Cloche pour plateaux
halbrollend, passend für Platten GN 1/1 ohne Griffe,
half rolling, fitting for trays GN 1/1 without handles,
demi-roulant, approprié pour plateaux GN 1/1 sans poignée

Länge length		Breite width		Höhe height		18/10 18/10
mm	in.	mm	in.	mm	in.	
540	21 ¹ / ₄	330	13	170	6 ³ / ₄	57.0170.9990



NEUTRAL

Kollektion FLEUR · Collection FLEUR



BUFFET



Buffetständer „S“, Buffet stand „S“, Support de buffet „S“

ohne Schale und Zubehör, without dish and accessoires, sans bol et accessoires

Höhe
height

mm in.

98 3⁷/₈ 57.0035.6040



FLEUR

Buffetständer „M“, Buffet stand „M“, Support de buffet „M“

ohne Schale und Zubehör, without dish and accessoires, sans bol et accessoires

Höhe
height

mm in.

136 5³/₈ 57.0036.6040



FLEUR

Buffetständer „L“, Buffet stand „L“, Support de buffet „L“

ohne Schale und Zubehör, without dish and accessoires, sans bol et accessoires

Höhe
height

mm in.

210 8¹/₄ 57.0037.6040



FLEUR

BUFFET

Universalständer, Multi purpose stand, Support pour service universel
drehbar, ohne Einsätze, revolving, without inserts, pivotant, sans insert

Höhe height		Ø-Außen Ø-outer		18/10 18/10
mm	in.	mm	in.	
760	29 ¹⁵ / ₁₆	497	19 ⁹ / ₁₆	12.2358.0000



NEUTRAL

Glaseinsatz, Glass insert, Insert en verre

Inhalt cap.		Höhe height		Ø-Außen Ø-outer		Glas glass
Ltr.	oz.	mm	in.	mm	in.	
2,00	70	105	4 ¹ / ₈	230	9 ¹ / ₁₆	50.8361.2250



NEUTRAL

Porzellan-Einsatz, Porcelain insert, Insert en porcelaine

Inhalt cap.		Höhe height		Ø-Außen Ø-outer		Porzellan porcelain
Ltr.	oz.	mm	in.	mm	in.	
0,80	28	88	3 ⁷ / ₁₆	145	5 ¹¹ / ₁₆	50.8362.1500



NEUTRAL

Etagere, Étagère
 3-tlg., 3-part, 3 parties

Höhe height		Ø-Außen Ø-outer		18/10 18/10	versilbert silver-plated
mm	in.	mm	in.		
622	24½	430	16 ⁵ / ₁₆	12.2243.4230	15.2243.4230



EXCELLENT

Obtschale, Fruit bowl, Coupe à fruits
 auf Fuß, with foot, sur pied

Höhe height		Ø-Außen Ø-outer		18/10 18/10	versilbert silver-plated
mm	in.	mm	in.		
109	4 ⁵ / ₁₆	234	9 ³ / ₁₆	12.2254.2300	15.2254.2300



EXCELLENT

Universalschale, All purpose bowl, Bol universel

Inhalt cap.		Höhe height		Ø-Außen Ø-outer		18/10 18/10
Ltr.	oz.	mm	in.	mm	in.	
1,5	53	84	3 ⁵ / ₁₆	232	9 ¹ / ₈	60.5454.0000



NEUTRAL

BUFFET

Tellerglocke, Cover, Cloche rund, round, rond

Ø-Innen		18/10
Ø-inner		18/10
mm	in.	
263	10 ³ / ₈	10.0507.2630
273	10 ³ / ₄	10.0507.2730
276	10 ⁷ / ₈	10.0507.2760
283	11 ¹ / ₈	10.0507.2830
285	11 ¹ / ₄	10.0507.2850
315	12 ³ / ₈	10.0507.3150



NEUTRAL

Tellerglocke, Cover, Cloche rund, round, rond

Ø-Innen		Kunststoff plastics
Ø-inner		
mm	in.	
261	10 ¹ / ₄	41.8019.2600
281	11 ¹ / ₁₆	41.8019.2800



NEUTRAL



Kollektion TIP TOP · Collection TIP TOP



TIPTOP



Fassung, Frame, Support

Höhe height		Ø-Außen Ø-outer		18/10 18/10
mm	in.	mm	in.	
126	4 ¹⁵ / ₁₆	61	2 ³ / ₈	57.0082.6040



TIPTOP

Glasbecher, Glass cup, Gobelet en verre passend zu Fassung TipTop, fitting to frame TipTop, approprié pour support TipTop

Höhe height		Ø-Außen Ø-outer		Glas glass
mm	in.	mm	in.	
72	2 ¹³ / ₁₆	58	2 ⁵ / ₁₆	57.0081.9990



TIPTOP

Porzellanbecher, Porcelain cup, Gobelet en porcelaine passend zu Fassung TipTop, fitting to frame TipTop, approprié pour support TipTop

Höhe height		Ø-Außen Ø-outer		Porzellan porcelain
mm	in.	mm	in.	
72	2 ¹³ / ₁₆	58	2 ⁵ / ₁₆	57.0080.9800



TIPTOP

Gabel, Fork, Fourchette

einzuhängen in die Fassung, to clip onto the frame, à accrocher sur le support

Länge length		18/10 18/10
mm	in.	
108	4 ¹ / ₄	57.0086.6040

Löffel, Spoon, Cuiller

einzuhängen in die Fassung, to clip onto the frame, à accrocher sur le support

Länge length		18/10 18/10
mm	in.	
110	4 ⁵ / ₁₆	57.0085.6040



TIPTOP

TIPTOP



Tischpräsentier, Presenter table, Présentateur table
für bis zu 6 ,TipTop', for up to 6 ,TipTop', jusqu'à 6 ,TipTop'

Höhe height		Ø-Außen Ø-outer		18/10 18/10
mm	in.	mm	in.	
231	9 ¹ / ₈	110	4 ⁵ / ₁₆	57.0083.6040



TIPTOP



Buffetpräsentier, Presenter buffet, Présentateur buffet
für bis zu 24 ,TipTop', mit Bodenplatte aus Stein und 2 Ebenen aus Glas,
for up to 24 ,TipTop', with a bottom plate of stone and 2 levels of glass,
jusqu'à 24 ,TipTop', avec une plateau de terre en pierre et 2 plateaus en verre

Höhe height		Ø-Außen Ø-outer		18/10 18/10
mm	in.	mm	in.	
634	24 ¹⁵ / ₁₆	305	12	57.0084.6040

TIPTOP



Das elegante Genusserlebnis an der Bar
The elegant taste experience at the bar





KALTGETRÄNKE & BAR · COLD DRINKS & BAR





Champagnerkühler, Champagne cooler, Seau à champagne
doppelwandig, auch geeignet als Eiskühler, für 2 Weinflaschen oder eine Champagnerflasche.

double walled, also used as an ice bucket, for 2 bottles of wine or 1 bottle of champagne.

double paroi, aussi approprié comme seau à glace, pour 2 bouteilles de vin ou 1 bouteille de champagne.

Höhe height		Ø-Außen Ø-outer		18/10
mm	in.	mm	in.	18/10
205	8 ¹ / ₁₆	216	8 ¹ / ₂	57.0096.6040

VISION



Deckel für Champagnerkühler, Lid for champagne cooler, Couvercle pour seau à champagne
kombinierbar mit 57.0096.6040, combinable with 57.0096.6040, combinable avec 57.0096.6040

Ø-Außen Ø-outer		18/10
mm	in.	18/10
190	7 ¹ / ₂	57.0115.6040

VISION

Weinkühler, Wine cooler, Seau à vin
für 2 Flaschen, for 2 bottles, pour 2 bouteilles

Höhe height		Ø-Außen Ø-outer		18/10	versilbert silver-plated
mm	in.	mm	in.	18/10	
247	9 ³ / ₄	231	9 ¹ / ₈	12.4018.2310	15.4518.2300



EXCELLENT

Weinkühler, Wine cooler, Seau à vin
für 2 Flaschen, for 2 bottles, pour 2 bouteilles

Höhe height		Ø-Außen Ø-outer		18/10 18/10	versilbert silver-plated
mm	in.	mm	in.		
247	9 ³ / ₄	231	9 ¹ / ₈	12.4818.2310	15.4818.2300



PROFILE

Weinkühler, Wine cooler, Seau à vin
für 1 Flasche, for 1 bottle, pour 1 bouteille

Höhe height		Ø-Außen Ø-outer		18/10 18/10	versilbert silver-plated
mm	in.	mm	in.		
219	8 ⁵ / ₈	189	7 ⁷ / ₁₆	12.4018.1910	15.4518.1900



EXCELLENT

Weinkühler, Wine cooler, Seau à vin
für 1 Flasche, for 1 bottle, pour 1 bouteille

Höhe height		Ø-Außen Ø-outer		18/10 18/10	versilbert silver-plated
mm	in.	mm	in.		
219	8 ⁵ / ₈	189	7 ⁷ / ₁₆	12.4818.1910	15.4818.1900



PROFILE

Weinkühler, Wine cooler, *Seau à vin*
für 1 Flasche, for 1 bottle, pour 1 bouteille

Höhe height		Ø-Außen Ø-outer		18/10 18/10	versilbert silver-plated
mm	in.	mm	in.		
210	8¼	168	6⅝	12.2318.1610	15.2318.1600



EXCELLENT

Weinkühler, Wine cooler, *Seau à vin*
für 1 Flasche, for 1 bottle, pour 1 bouteille

Höhe height		Ø-Außen Ø-outer		18/10 18/10	versilbert silver-plated
mm	in.	mm	in.		
210	8¼	168	6⅝	12.4818.1610	15.4818.1600



PROFILE

Weinkühler, Wine cooler, *Seau à vin*
oval, für 2 Flaschen, oval, for 2 bottles, ovale, pour 2 bouteilles

Länge length		Breite width		Höhe height		18/10 18/10	versilbert silver-plated
mm	in.	mm	in.	mm	in.		
265	10⅞	223	8¾	210	8¼	12.2233.2710	15.2233.2710



EXCELLENT

**Flaschenkühler mattiert, Bottle-cooler satin finished,
Rafraîchisseur satinée à bouteilles**

isoliert, insulated, isolé

Höhe height		Ø-Außen Ø-outer		18/10
mm	in.	mm	in.	18/10
190	7 ¹ / ₈	120	4 ³ / ₄	60.5449.0000



NEUTRAL

**Ständer für Champagnerkühler, Stand for champagne cooler,
Support pour seau à champagne**

Höhe height		Ø-Außen Ø-outer		18/10
mm	in.	mm	in.	18/10
600	23 ⁵ / ₈	200	7 ⁷ / ₈	57.0114.6040



VISION

**Weinkühlerständer, Stand for wine cooler, Support pour seau à vin
für 1 Flasche, for 1 bottle, pour 1 bouteille**

Höhe height		Ø-Innen Ø-inner		18/10	versilbert silver-plated
mm	in.	mm	in.	18/10	13.2255.6860
676	26 ⁵ / ₈	162	6 ³ / ₈	12.2255.6860	13.2255.6860

für 2 Flaschen, for 2 bottles, pour 2 bouteilles

Höhe height		Ø-Innen Ø-inner		18/10	versilbert silver-plated
mm	in.	mm	in.	18/10	13.2255.6880
688	27 ¹ / ₁₆	180	7 ¹ / ₁₆	12.2255.6880	13.2255.6880



EXCELLENT



Weinkühlerständer, Stand for wine cooler, Support pour seau à vin
für 1 Flasche, for 1 bottle, pour 1 bouteille

Höhe height		Ø-Innen Ø-inner		18/10 18/10	versilbert silver-plated
mm	in.	mm	in.		
676	26 ⁵ / ₈	162	6 ³ / ₈	12.4855.6860	13.4855.6860

für 2 Flaschen, for 2 bottles, pour 2 bouteilles

Höhe height		Ø-Innen Ø-inner		18/10 18/10	versilbert silver-plated
mm	in.	mm	in.		
688	27 ¹ / ₁₆	180	7 ¹ / ₁₆	12.4855.6880	13.4855.6880

PROFILE



Weinkühlerständer, Stand for wine cooler, Support pour seau à vin
oval, ovale

Länge length		Breite width		Höhe height		18/10 18/10	versilbert silver-plated
mm	in.	mm	in.	mm	in.		
239	9 ⁷ / ₁₆	173	6 ¹³ / ₁₆	671	26 ⁷ / ₁₆	12.2234.0000	13.2234.0000

EXCELLENT



Rotweingestell, Red wine holder, Porte-bouteilles
für Flasche 0,375 ltr., 0,75 ltr., 1,50 ltr., for bottle 13 oz, 26 oz, 53 oz,
pour bouteille 0,375 ltr., 0,75 ltr., 1,50 ltr.

Länge length		Breite width		18/10 18/10	versilbert silver-plated
mm	in.	mm	in.		
315	12 ³ / ₈	138	5 ⁷ / ₁₆	12.2296.0000	13.2296.0000

NEUTRAL

Rotweinkorb, Wine basket, Panier à vin
für Flasche 0,75 ltr., for bottle 26 oz, pour bouteille 0,75 ltr.

Länge length		Breite width		versilbert silver-plated
mm	in.	mm	in.	
248	9 ³ / ₄	110	4 ⁵ / ₁₆	60.9186.0750



NEUTRAL

Champagnerschüssel, Champagne bowl, Seau à champagne

ohne Einsatzring, without ring for glass insert, sans anneau

Inhalt cap.		Höhe height		Ø-Außen Ø-outer		18/10		versilbert silver-plated
Ltr.	oz.	mm	in.	mm	in.	12.2275.3700	15.2275.3700	
13,00	458	300	11 ¹³ / ₁₆	385	15 ⁹ / ₁₆	12.2275.3700	15.2275.3700	

ohne Einsatzring, mit Griff und Galerie (ohne Abbildung),
without ring for glass insert, with handle and gallery (without image),
sans anneau, avec poignée et galerie (sans image)

Inhalt cap.		Höhe height		Ø-Außen Ø-outer		18/10		versilbert silver-plated
Ltr.	oz.	mm	in.	mm	in.	12.2275.5600	15.2275.5600	
36,00	1267	395	15 ⁹ / ₁₆	570	22 ⁷ / ₁₆	12.2275.5600	15.2275.5600	



EXCELLENT

Champagnerschüssel, Champagne bowl, Seau à champagne

ohne Einsatzring, without ring for glass insert, sans anneau

Inhalt cap.		Höhe height		Ø-Außen Ø-outer		18/10		versilbert silver-plated
Ltr.	oz.	mm	in.	mm	in.	12.4875.3700	13.4875.3700	
13,00	458	303	11 ¹⁵ / ₁₆	385	15 ⁹ / ₁₆	12.4875.3700	13.4875.3700	



PROFILE

Eiswasserkanne, Water pitcher, Carafe à eau glacée
mit Eislippe, doppelwandig, with ice-lip, double-walled,
avec lip glacés, double paroi



Inhalt cap.		18/10 18/10	
Ltr.	oz.		
1,50	53		60.5461.0000

NEUTRAL

Eiswasserkanne, Water pitcher, Carafe à eau glacée



Inhalt cap.		18/10 18/10	versilbert silver-plated
Ltr.	oz.		
2,00	70	12.4404.2000	13.4404.2000

mit Eislippe, with ice-lip, avec lip glacés

Inhalt cap.		18/10 18/10	versilbert silver-plated
Ltr.	oz.		
2,00	70	12.4408.2000	13.4408.2000

PROFILE

Eiswasserkanne, Water pitcher, Carafe à eau glacée



Inhalt cap.		18/10 18/10	versilbert silver-plated
Ltr.	oz.		
2,00	70	12.2104.2000	13.3104.2000

mit Eislippe, with ice-lip, avec lip glacés

Inhalt cap.		18/10 18/10	versilbert silver-plated
Ltr.	oz.		
2,00	70	12.2108.2000	13.3108.2000

EXCELLENT

Eiswasserkanne, Water pitcher, Carafe à eau glacée
mit Eislippe, with ice-lip, avec lip glacés



Inhalt cap.		18/10 18/10	versilbert silver-plated
Ltr.	oz.		
1,50	53	12.2208.1500	13.2208.1500

AVANTGARDE

Eiswasserkanne, Ice water pitcher, Carafe à eau glacée
doppelwandig, double walled, double paroi

Inhalt cap.		18/10 18/10		
Ltr.	oz.			60.5331.1800
1,80	66			



NEUTRAL

Roheisbehälter, Ice bucket, Seau à glace
doppelwandig, double walled, double paroi

Höhe height		Ø-Außen Ø-outer		18/10 18/10
mm	in.	mm	in.	60.5497.0000
194	7 ⁵ / ₈	148	5 ¹³ / ₁₆	



EXCELLENT

Roheisbehälter, Ice bucket, Seau à glace
doppelwandig, double walled, double paroi

Höhe height		Ø-Außen Ø-outer		18/10 18/10
mm	in.	mm	in.	12.4997.0000
191	7 ¹ / ₂	148	5 ¹³ / ₁₆	



PROFILE

Roheisbehälter, Ice bucket, Seau à glace
mit Roheiszange, with ice tongs, avec pince à glace

Höhe height		Ø-Außen Ø-outer		18/10 18/10
mm	in.	mm	in.	60.5491.0000
230	9 ¹ / ₁₆	131	5 ³ / ₁₆	



NEUTRAL



Roheisbehälter, Ice bucket, Seau à glace
mit Roheiszange, with ice tongs, avec pince à glace

Höhe height		Ø-Außen Ø-outer		18/10
mm	in.	mm	in.	18/10
163	6 ⁷ / ₁₆	150	5 ¹⁴ / ₁₆	57.0038.6040

NEUTRAL



Roheisbehälter, Ice bucket, Seau à glace

Höhe height		Ø-Außen Ø-outer		18/10	versilbert silver-plated
mm	in.	mm	in.	18/10	
121	4 ³ / ₄	126	4 ¹⁵ / ₁₆	12.2219.0000	15.2219.0000

EXCELLENT



Roheisbehälter, Ice bucket, Seau à glace

Höhe height		Ø-Außen Ø-outer		18/10	versilbert silver-plated
mm	in.	mm	in.	18/10	
121	4 ³ / ₄	126	4 ¹⁵ / ₁₆	12.4919.0000	15.4919.0000

PROFILE



Roheisbehälter, Ice bucket, Seau à glace

Höhe height		Ø-Außen Ø-outer		18/10	versilbert silver-plated
mm	in.	mm	in.	18/10	
121	4 ³ / ₄	126	4 ¹⁵ / ₁₆	60.5419.0000	60.7419.0000

NEUTRAL

Zigarrenabschneider, Cigar cutter, Coupe-cigare

Länge length		18/10 18/10	
mm	in.		
100	3 ¹⁵ / ₁₆		57.0063.6040



NEUTRAL

Roheisschaufel, Ice shovel, Pelle à glace

Länge length		18/10 18/10	
mm	in.		
165	6 ¹ / ₂		12.5015.0000



NEUTRAL

Roheiszange, Ice tongs, Pince à glace

Länge length		18/10 18/10	versilbert silver-plated
mm	in.		
156	6 ¹ / ₈	60.8834.0000	60.9034.0000



NEUTRAL

Barständer, Snack stand, Support à snack
3-tlg., 3-part, 3 parties

Höhe height		18/10 18/10	versilbert silver-plated
mm	in.		
247	9 ³ / ₄	12.2235.0000	15.2235.0000



EXCELLENT



Barständer, Snack stand, Support à snack
3-tlg., 3-part, 3 parties

Höhe height		18/10 18/10	versilbert silver-plated
mm	in.		
163	6 ⁷ / ₁₆	12.4837.0000	15.4837.0000

PROFILE



Barständer, Snack stand, Support à snack
3-tlg., 3-part, 3 parties

Höhe height		18/10 18/10	versilbert silver-plated
mm	in.		
168	6 ⁵ / ₈	12.2237.0000	15.2237.0000

EXCELLENT



Barständer, Snack stand, Support à snack
4-tlg., 4-part, 4 parties

Höhe height		18/10 18/10	versilbert silver-plated
mm	in.		
228	9	12.2236.0000	15.2236.0000

EXCELLENT



Buffetständer „S“, Buffet stand „S“, Support de buffet „S“

ohne Schale und Zubehör, without dish and accessoires, sans bol et accessoires

Höhe height			
mm	in.		
98	3 ⁷ / ₈		57.0035.6040

FLEUR

Buffetständer „M“, Buffet stand „M“, Support de buffet „M“

ohne Schale und Zubehör, without dish and accessoires, sans bol et accessoires

Höhe
height

mm	in.	
136	5 ³ / ₈	57.0036.6040



FLEUR

Buffetständer „L“, Buffet stand „L“, Support de buffet „L“

ohne Schale und Zubehör, without dish and accessoires, sans bol et accessoires

Höhe
height

mm	in.	
210	8 ¹ / ₄	57.0037.6040



FLEUR

Flaschen-Gläserteller, Bottle and glass tray, Porte bouteilles et verres

Ø-Außen Ø-outer		18/10	versilbert silver-plated
mm	in.		
101	4	10.0609.1000	11.1609.1000
142	5 ⁹ / ₁₆	10.0609.1400	11.1609.1400



NEUTRAL

Zahnstocherbehälter, Toothpick stand, Porte cure-dents

Höhe height		18/10	versilbert silver-plated
mm	in.		
80	3 ¹ / ₈	12.2231.0000	13.2231.0000



NEUTRAL

ARTE



SONDERKOLLEKTIONEN · SPECIAL COLLECTIONS



Chafing Dish ø 30cm



Chafing Dish GN 1/1



Leuchter, Candelabra, Chandelier



Gebäckständer, Pastry stand, Porte-petits-fours



Kugelglocke, Dome cover, Cloche ronde

Dies ist ein Auszug aus unserer Sonderkollektion ARTE. Weitere Artikel finden Sie online unter www.hepp.de.
This is an overview of our Special Collection ARTE. More information online: www.hepp.de.

EXCLUSIVE



SONDERKOLLEKTIONEN · SPECIAL COLLECTIONS



Coffee Urn



Chafing Dish GN 1/1



Kugelglocke, Dome cover, Cloche ronde



Chafing Dish, Ø 40cm



Gebäckständer, Pastry stand, Porte-petit-fours
3-tlg., 3-part, 3 parties

Dies ist ein Auszug aus unserer Sonderkollektion EXCLUSIVE. Weitere Artikel finden Sie online unter www.hepp.de.
This is an overview of our Special Collection EXCLUSIVE. More information online: www.hepp.de.

Die Kunst, Genuss glanzvoll zu präsentieren
The art of glamorous food presentation





SERVIERWAGEN · SERVING TROLLIES

Farben · Colours



001 Kirsch,
Holz furniert
001 Cherry,
Wood veneered



002 Mahagoni,
Holz furniert
002 Mahogany,
Wood veneered

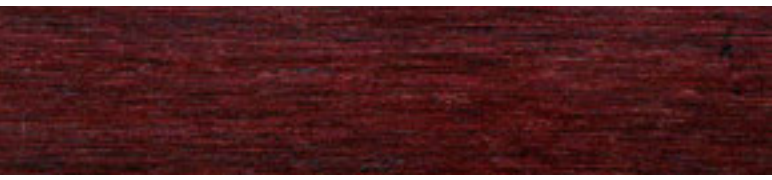

003 Palisander,
Holz furniert
003 Rosewood,
Wood veneered



004 Nuss dunkel,
Holz furniert
004 Nut dark,
Wood veneered



005 Nuss hell,
Holz furniert
005 Nut light,
Wood veneered



006 Weiß,
Holz furniert
006 White,
Wood veneered



008 Bordeaux,
Holz furniert
008 Bordeaux,
Wood veneered

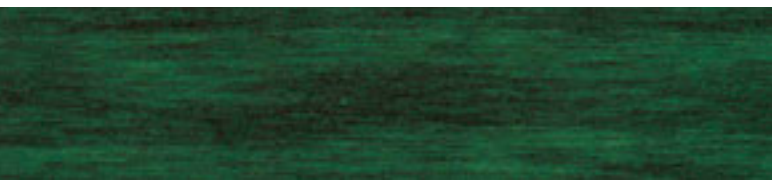

009 Grün,
Holz furniert
009 Green,
Wood veneered



011 Wenge,
Holz furniert
011 Wenge,
Wood veneered



010 Schwarz,
Holz furniert
010 Black,
Wood veneered

Farben Nr. 006, 008, 009, 010, 011 und Sonderfarben sind gegen Aufpreis erhältlich.

Colours No. 006, 008, 009, 010, 011 and special colours are available for an extra charge.

Die abgebildeten Farben sind unverbindlich. Unregelmäßigkeiten in Farbe und Maserung sind möglich.

The shown colours are without obligation. Irregularities of the colours and the grain are possible.

Digestifwagen, Liquor trolley, Chariot à digestifs

Edelholzrahmen, Digestifaufsatz, ausziehbare Arbeitsplatte.

Unit frame made of finest quality natural wood, top for alcoholic beverages, sliding shelf.

Châssis en bois précieux, élément supérieur à digestifs, tiroir.

Länge length		Breite width		Höhe height		
mm	in.	mm	in.	mm	in.	
1030	40 ⁹ / ₁₆	540	21 ¹ / ₄	910	35 ¹³ / ₁₆	30.7901.0000



ELEGANCE

Sorbetwagen, Sorbet trolley, Chariot à sorbets

Edelholzrahmen, Sorbetaufsatz, ohne Sorbetbehälter, Digestifaufsatz, ausziehbare Arbeitsplatte.

Unit frame made of finest quality natural wood, top for sorbets, without sorbet pots, top for alcoholic beverages, sliding shelf.

Châssis en bois précieux, élément supérieur à sorbets, sans pots à sorbet, élément supérieur à digestifs, tiroir.

Länge length		Breite width		Höhe height		
mm	in.	mm	in.	mm	in.	
1030	40 ⁹ / ₁₆	540	21 ¹ / ₄	890	35 ¹ / ₁₆	30.7903.0000



ELEGANCE

Weinwagen, Wine trolley, Chariot à vins

Edelholzrahmen, Glashalter, Isolierbehälter für Weinflaschen, ausziehbare Arbeitsplatte und Schublade.

Unit frame made of finest quality natural wood, glass holder, isolated containers for wine bottles, sliding shelf and drawer.

Châssis en bois précieux, porte-verres, récipients isolants pour bouteilles à vin, 2 tiroirs.



Länge length		Breite width		Höhe height		
mm	in.	mm	in.	mm	in.	
1030	40 ⁹ / ₁₆	540	21 ¹ / ₄	890	35 ¹ / ₁₆	30.7928.0000

ELEGANCE

Flaschenträger für 6 Flaschen, Holder for 6 bottles, Support pour 6 bouteilles

Länge length		Breite width		Höhe height		18/10 18/10
mm	in.	mm	in.	mm	in.	
420	16 ⁹ / ₁₆	340	13 ³ / ₈	253	9 ¹⁵ / ₁₆	30.7928.0010



ELEGANCE

Humidorwagen, Cigar trolley, Chariot à cigares

Edelholzrahmen, Digestifaufsatz mit Glashalter, 2 Zigarrenfächer mit Befeuchter und Hygrometer, abschließbar, ausziehbare Arbeitsplatte.

Unit frame made of finest quality natural wood, top for alcoholic beverages with glass holder, 2 compartments for cigars with moistener and hygrometer, lockable, sliding shelf.

Châssis en bois précieux, élément supérieur à digestifs avec porte-verres, 2 compartiments pour cigares avec humidificateur et hygromètre, qui ferment à clé, tiroir.

Länge length		Breite width		Höhe height		
mm	in.	mm	in.	mm	in.	
1030	40 ⁹ / ₁₆	540	21 ¹ / ₄	890	35 ¹ / ₁₆	30.7927.0000



ELEGANCE

Servierwagen - Grundmodell, Serving trolley - basic model, Chariot à service - modèle de base

Grundmodell für alle Aufsätze, Edelholzrahmen, ausziehbare Arbeitsplatte.

Basic model for all tops, unit frame made of finest quality natural wood, sliding shelf.

Modèle de base pour tous les éléments supérieurs, Châssis en bois précieux, tiroir.

Länge length		Breite width		Höhe height		
mm	in.	mm	in.	mm	in.	
1030	40 ⁹ / ₁₆	540	21 ¹ / ₄	810	31 ⁷ / ₈	30.7900.0000



ELEGANCE

**Kuchen- und Nachspeisenwagen, Pastry and dessert trolley,
Chariot à pâtisseries et desserts**

Edelholzrahmen, Kühlaufsatz 18/10 mit 4 Kühlpellets, Plexiglashaube, ausziehbare Arbeitsplatte.

Unit frame made of finest quality natural wood, top 18/10 for cooling with 4 cooling pellets, plexiglass hood, sliding shelf.

Châssis en bois précieux, élément supérieur à rafraîchir en 18/10 avec 4 plaque eutectique, cloche en verre plexi, tiroir.



Länge length		Breite width		Höhe height		30.7902.0000
mm	in.	mm	in.	mm	in.	
1030	40 ⁹ / ₁₆	540	21 ¹ / ₄	870	34 ¹ / ₄	

ELEGANCE

**Kuchen- und Nachspeisenwagen, Pastry and dessert trolley,
Chariot à pâtisseries et desserts**

Edelholzrahmen mit Plexiglashaube, umluftgekühlt, thermostatisch regelbar, ausziehbare Arbeitsplatte.

Unit frame made of finest quality natural wood, with plexiglass hood, recirculating cooling, thermostatically adjustable, sliding shelf.

Châssis en bois précieux, cloche en verre plexi, refroidissement à l'air recyclé, réglable par thermostat, tiroir.



Länge length		Breite width		Höhe height		Netzspannung line voltage	30.7916.0000
mm	in.	mm	in.	mm	in.	Volt	
1030	40 ⁹ / ₁₆	540	21 ¹ / ₄	890	35 ¹ / ₁₆	220	

ELEGANCE

Meeresfrüchtewagen, Seafood trolley, Chariot à fruits de mer

Edelholzrahmen, Holzaufsatz mit Roheiswanne 18/10, ausziehbare Arbeitsplatte.

Unit frame made of finest quality natural wood, wooden top with container 18/10 for ice, sliding shelf.

Châssis en bois précieux, élément supérieur en bois avec récipient en 18/10 pour glace, tiroir.

Länge length		Breite width		Höhe height		
mm	in.	mm	in.	mm	in.	
1030	40 ⁹ / ₁₆	540	21 ¹ / ₄	890	35 ¹ / ₁₆	30.7905.0000



ELEGANCE

Käsewagen, Cheese trolley, Chariot à fromage

Edelholzrahmen, Käseaufsatz mit halbrollender Plexiglashaube, Kunstmarmorplatte, ausziehbare Arbeitsplatte.

Unit frame made of finest quality natural wood, top for cheese, with roll top plexiglass hood, artificial marble plate, sliding shelf.

Châssis en bois précieux, élément supérieur à fromage, avec roll-top en verre plexi, plateau en marbre artificiel, tiroir.

Länge length		Breite width		Höhe height		
mm	in.	mm	in.	mm	in.	
1030	40 ⁹ / ₁₆	540	21 ¹ / ₄	1060	41 ³ / ₄	30.7914.0000



ELEGANCE

Induktionswagen, Induction trolley, Chariot à l'induction

Edelholzrahmen mit Induktionsherd, Flaschenhalter, ausziehbare Arbeitsplatte und Schublade.

Unit frame made of finest quality natural wood, with induction stove, bottle holder, sliding shelf and drawer.

Châssis en bois précieux, avec fourneau d'induction, porte-bouteilles, 2 tiroirs.

Länge length		Breite width		Höhe height		Netzspannung line voltage	
mm	in.	mm	in.	mm	in.	Volt	
1030	40 ⁹ / ₁₆	540	21 ¹ / ₄	890	35 ¹ / ₁₆	230	30.7926.0000



ELEGANCE

Chafing Dish Wagen, Chafing Dish trolley, Chariot à Chafing Dish

Edelholzrahmen, ganz rollende Haube 18/10, Ablage für Tranchierbesteck und klappbare Abstellplatte, elektrisch beheizbar, ohne Elektroheizung, ohne Einsätze, Zubehör im Bereich Chafing Dish Zubehör.

Unit frame made of finest quality natural wood, full roll top cover 18/10, basin for the cutlery and hinged side plate, for electric heating, without electric heating element, without inserts, accessory in the category chafing dish accessory.

Châssis en bois précieux, couvercle roulant 18/10, pour couverts et tablette pliante, électrique, sans chauffage électrique, sans récipients, accessoire dans le domaine du Chafing Dish accessoire.

Länge length		Breite width		Höhe height		30.7929.0000
mm	in.	mm	in.	mm	in.	
1030	40 ⁹ / ₁₆	540	21 ¹ / ₄	995	39 ³ / ₁₆	



ELEGANCE

Rinderbrustwagen, Roast beef trolley, Chariot à viande

Edelholzrahmen, ganz rollende Haube 18/10, klappbare Abstellplatte, abnehmbare Halterung für Tranchierbesteck, elektrisch beheizt.

Unit frame made of finest quality natural wood, full roll top cover 18/10, hinged side plate, removable holder for carving set, electric heating.

Châssis en bois précieux, couvercle roll-top en 18/10, tablette pliante, porte-couverts à découper, chauffage électrique.

Länge length		Breite width		Höhe height		Netzspannung line voltage	
mm	in.	mm	in.	mm	in.	Volt	
1080	42 ¹ / ₂	610	24	1040	40 ¹⁵ / ₁₆	220	30.7907.0000

Länge length		Breite width		Höhe height		Netzspannung line voltage	
mm	in.	mm	in.	mm	in.	Volt	
1080	42 ¹ / ₂	610	24	1040	40 ¹⁵ / ₁₆	110	30.7907.1000



ELEGANCE

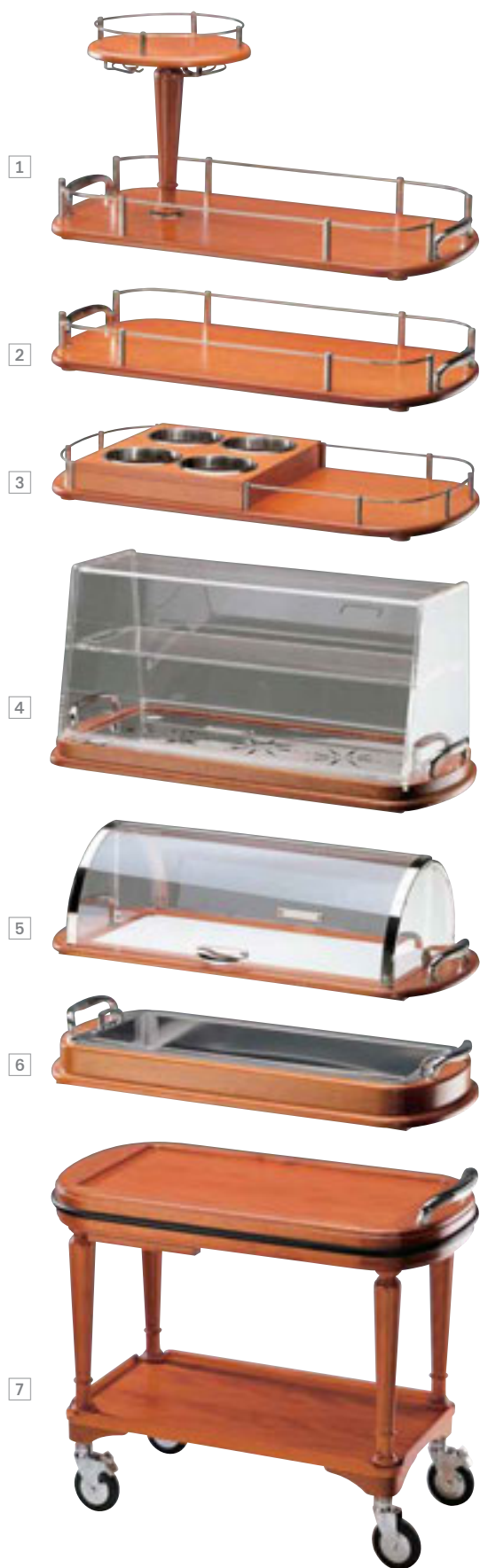

1 Digestifaufsatz mit Glashalter, Top for alcoholic beverages with glass holder, Élément supérieur à digestifs avec porte-verres

Länge length		Breite width		Höhe height		30.7908.0010
mm	in.	mm	in.	mm	in.	
920	36 ¹ / ₄	460	18 ¹ / ₈	420	16 ⁹ / ₁₆	

2 Digestifaufsatz, Top for alcoholic beverages, Élément supérieur à digestifs

Länge length		Breite width		Höhe height		30.7901.0010
mm	in.	mm	in.	mm	in.	
920	36 ¹ / ₄	460	18 ¹ / ₈	100	3 ¹⁵ / ₁₆	

3 Sorbetaufsatz, Top for sorbets, Élément supérieur à sorbets

Länge length		Breite width		Höhe height		30.7903.0010
mm	in.	mm	in.	mm	in.	
920	36 ¹ / ₄	460	18 ¹ / ₈	80	3 ¹ / ₈	

4 Kühlaufsatz mit Plexiglashaube, Top for cooling with plexiglass hood, Élément supérieur à rafraîchir avec cloche en verre plexi

Länge length		Breite width		Höhe height		30.7902.0010
mm	in.	mm	in.	mm	in.	
920	36 ¹ / ₄	460	18 ¹ / ₈	430	16 ¹⁵ / ₁₆	

5 Käseaufsatz, Top for cheese, Élément supérieur à fromage

Länge length		Breite width		Höhe height		30.7914.0010
mm	in.	mm	in.	mm	in.	
920	36 ¹ / ₄	460	18 ¹ / ₈	250	9 ¹⁵ / ₁₆	

6 Meeresfrüchteaufsatz, Top for seafood, Élément supérieur pour fruits de mer

Länge length		Breite width		Höhe height		30.7905.0010
mm	in.	mm	in.	mm	in.	
920	36 ¹ / ₄	460	18 ¹ / ₈	80	3 ¹ / ₈	

7 Servierwagen - Grundmodell, Serving trolley - basic model, Chariot à service - modèle de base

Grundmodell für alle Aufsätze, Edelholzrahmen, ausziehbare Arbeitsplatte.

Basic model for all tops, unit frame made of finest quality natural wood, sliding shelf.

Modèle de base pour tous les éléments supérieurs, Châssis en bois précieux, tiroir.

Länge length		Breite width		Höhe height		30.7900.0000
mm	in.	mm	in.	mm	in.	
1030	40 ⁹ / ₁₆	540	21 ¹ / ₄	810	31 ⁷ / ₈	

ELEGANCE

Digestifwagen rund, Liquor trolley round, Chariot à digestifs, rond

Edelholzrahmen, Digestifaufsatz, ausziehbare Arbeitsplatte. Galerie auf Bodenplatte.

Unit frame made of finest quality natural wood, top for alcoholic beverages, sliding shelf. Gallery on the bottom shelf.

Châssis en bois précieux, élément supérieur à digestifs, tiroir, galerie sur plat en bas.

Höhe height		Ø-Außen Ø-outer		
mm	in.	mm	in.	
800	31½	620	24 ⁷ / ₁₆	30.7924.1020



ELEGANCE

Käsewagen rund, Cheese trolley round, Chariot à fromage, rond

Edelholzrahmen, Käseaufsatz, Schneidbrett aus Kunststoff Ø 450 mm drehbar, halbrollende Plexiglashaube, ausziehbare Arbeitsplatte. Galerie auf Bodenplatte.

Unit frame made of finest quality natural wood, top for cheese, plastic cutting board Ø 450 mm revolving, with half roll top plexiglass hood, sliding shelf. Gallery on the bottom shelf.

Châssis en bois précieux, élément supérieur à fromage, planche à couper en plastique Ø 450 mm pivotante, avec semi roll-top en verre plexi, tiroir, galerie sur plat en bas.

Höhe height		Ø-Außen Ø-outer		
mm	in.	mm	in.	
800	31½	620	24 ⁷ / ₁₆	30.7924.1010



ELEGANCE

1



1 Käseaufsatz rund, Top for cheese round, Élément supérieur à fromage, rond
Schneidbrett aus Kunststoff Ø 450 mm drehbar, halbröllende Plexiglashaube.

Plastic cutting board Ø 17¹¹/₁₆ inch revolving, with half roll top plexiglass hood.

Planche à couper en plastique Ø 450 mm pivotante, avec semi roll-top en verre plexi.

Höhe height		Ø-Außen Ø-outer		
mm	in.	mm	in.	
300	11 ¹³ / ₁₆	530	20 ⁷ / ₈	30.7924.0010

2



2 Digestifaufsatz rund, Top for alcoholic beverages round,
Élément supérieur à digestifs, rond

mit Galerie, with gallery, avec galerie

Höhe height		Ø-Außen Ø-outer		
mm	in.	mm	in.	
100	3 ¹⁵ / ₁₆	610	24	30.7924.0020

3



3 Aufsatz für Servierwagen, Top for serving trolley,
Élément supérieur pour chariot de service

Höhe height		Ø-Außen Ø-outer		
mm	in.	mm	in.	
20	¹³ / ₁₆	610	24	30.7924.0030

4



4 Servierwagen rund, Serving trolley round, Chariot à service ronde

Grundmodell für alle Aufsätze, Edelholzrahmen, ausziehbare Arbeitsplatte. Galerie auf Bodenplatte., Das Grundmodell ist nur mit Aufsatz verwendbar.

Basic model for all tops, unit frame made of finest quality natural wood, sliding shelf. Gallery on the bottom shelf., The basic model can only be used with a top.

Modèle de base pour tous les éléments supérieurs. Châssis en bois précieux, tiroir. Galerie sur plat en bas., Le modèle de base n'est utilisable qu'avec élément supérieur.

Höhe height		Ø-Außen Ø-outer		
mm	in.	mm	in.	
800	31 ¹ / ₂	620	24 ⁷ / ₁₆	30.7924.0000

ELEGANCE

ROOMSERVICEWAGEN · ROOM-SERVICE-TROLLY ·
VOITURE POUR SERVICE D'ÉTAGE



1 Roomservicewagen, Room-Service-Trolley, Chariot pour service d'étage

Stabiles Vierkantröhr aus Edelstahl 18/10, kunststoffbeschichtete Tischplatte mit stabilen Scharnieren, abklappbar, Einschubscharnieren für Warmhaltebox.

Sturdy rectangular tube rack made of stainless steel 18/10, plastic laminated table-top with stable hinges, foldable, Slide-in rails for thermal box.

Profilé carré à haute résistance en acier inoxydable 18/10, plateau de table stratifié avec charnières résistantes, faces latérales rabattables. Rails pour box isotherme.

Seitenteile geklappt, 530 mm breit.
Side-parts foldable, 20⁷/₈ inch.
Parties latérales rabattues 530 mm.

Höhe height		Ø		
mm	in.	mm	in.	
770	30 ⁵ / ₁₆	1100	43 ⁵ / ₁₆	30.7930.0000

2 Warmhaltebox, Thermal Box, Box isotherme

Für Teller Ø 28 cm, aus Edelstahl 18/10, Innenraum mit 2 Ablagen, elektrisch aufheizbar bis max 80°.

For plate Ø 11 inch, made of stainless steel 18/10, interior with 2 shelves. The thermal box can be heated electrically to a maximum of 176° F.

Pour assiette Ø 28 cm, acier inoxydable, avec deux étagères à l'intérieur, chauffage électrique jusqu'à 80 ° C au maximum.

Nennleistung 250 W, Sicherung 16 A, Power Supply 250 W, FUSE 16 A,
Homologué 250 W, Fusible 16 A

Länge length		Breite width		Höhe height		Netzspannung line voltage		
mm	in.	mm	in.	mm	in.	Volt		
340	13 ³ / ₈	340	13 ³ / ₈	400	15 ³ / ₄	220/50Hz	18/10	30.7979.0010



1



2

NEUTRAL

Digestifwagen, Liquor trolley, Chariot à digestifs

Edelholzrahmen, Digestifaufsatz, ausziehbare Arbeitsplatte und Schublade.

Unit frame made of finest quality natural wood, top for alcoholic beverages, sliding shelf and drawer.

Châssis en bois précieux, élément supérieur à digestifs, 2 tiroirs.



Länge length		Breite width		Höhe height		30.8009.0000
mm	in.	mm	in.	mm	in.	
1010	39 ³ / ₄	530	20 ⁷ / ₈	1070	42 ¹ / ₈	

PROFILE

Digestifwagen, Liquor trolley, Chariot à digestifs

Edelholzrahmen, Digestifaufsatz mit Glashalter, ausziehbare Arbeitsplatte und Schublade.

Unit frame made of finest quality natural wood, top for alcoholic beverages with glass holder, sliding shelf and drawer.

Châssis en bois précieux, porte-verres, élément supérieur à digestifs, 2 tiroirs.



Länge length		Breite width		Höhe height		30.8008.0000
mm	in.	mm	in.	mm	in.	
1010	39 ³ / ₄	530	20 ⁷ / ₈	1270	50	

PROFILE

Sorbetwagen, Sorbet trolley, Chariot à sorbets

Edelholzrahmen, Sorbetaufsatz, Digestifaufsatz, ausziehbare Arbeitsplatte und Schublade, ohne Sorbetbehälter.

Unit frame made of finest quality natural wood, top for sorbets, top for alcoholic beverages, sliding shelf and drawer, without sorbet pots.

Châssis en bois précieux, élément supérieur à sorbet, élément supérieur à digestifs, 2 tiroirs, sans pots à sorbet.

Länge length		Breite width		Höhe height		30.8003.0000
mm	in.	mm	in.	mm	in.	
1010	39 ³ / ₄	530	20 ⁷ / ₈	910	35 ¹³ / ₁₆	



PROFILE

Humidorwagen, Cigar trolley, Chariot à cigares

Edelholzrahmen, Digestifaufsatz mit Glashalter, 2 Zigarettenfächer mit Befeuchter und Hygrometer, abschließbar, ausziehbare Arbeitsplatte und Schublade.

Unit frame made of finest quality natural wood, top for alcoholic beverages with glass holder, 2 compartments for cigars with moistener and hygrometer, lockable, sliding shelf and drawer.

Châssis en bois précieux, élément supérieur à digestifs avec porte-verres, 2 compartiments pour cigares avec humidificateur et hygromètre, qui ferment à clé, 2 tiroirs.

Länge length		Breite width		Höhe height		30.8027.0000
mm	in.	mm	in.	mm	in.	
1010	39 ³ / ₄	530	20 ⁷ / ₈	1270	50	



PROFILE

**Kuchen- und Nachspeisenwagen, Pastry and dessert trolley,
Chariot à pâtisseries et desserts**

Edelholzrahmen, Kühlaufsatz 18/10, mit 6 Kühlpellets, Plexiglashaube, ausziehbare Arbeitsplatte und Schublade.

Unit frame made of finest quality natural wood, top 18/10 for cooling with 6 cooling pellets, plexiglass hood, sliding shelf and drawer.

Châssis en bois précieux, élément supérieur à rafraîchir en 18/10 avec 6 plaque eutectique, cloche en verre plexi, 2 tiroirs.



Länge length		Breite width		Höhe height		30.8002.0000
mm	in.	mm	in.	mm	in.	
1010	39 ³ / ₄	530	20 ⁷ / ₈	1110	43 ¹¹ / ₁₆	

PROFILE

Käsewagen, Cheese trolley, Chariot à fromage

Edelholzrahmen, Käseaufsatz mit halbbrollender Plexiglashaube, Kunstmarmorplatte, ausziehbare Arbeitsplatte und Schublade.

Unit frame made of finest quality natural wood, top for cheese, with roll top plexiglass hood, artificial marble plate, sliding shelf and drawer.

Châssis en bois précieux, élément supérieur à fromage, avec full roll-top en verre plexi, plateau en marbre artificiel, 2 tiroirs.



Länge length		Breite width		Höhe height		30.8014.0000
mm	in.	mm	in.	mm	in.	
1010	39 ³ / ₄	530	20 ⁷ / ₈	1080	42 ¹ / ₈	

PROFILE

Meeresfrüchtewagen, Seafood trolley, Chariot à fruits de mer

Edelholzrahmen, Holzaufsatz mit Roheiswanne 18/10, ausziehbare Arbeitsplatte und Schublade.

Unit frame made of finest quality natural wood, wooden top with container 18/10 for ice, sliding shelf and drawer.

Châssis en bois précieux, éléments supérieur en bois avec récipient en 18/10 pour glace, 2 tiroirs.

Länge length		Breite width		Höhe height		
mm	in.	mm	in.	mm	in.	
1010	39 ³ / ₄	530	20 ⁷ / ₈	940	37	30.8005.0000



PROFILE

Induktionswagen, Induction trolley, Chariot à l'induction

Edelholzrahmen mit Induktionsherd, Flaschenhalter, ausziehbare Arbeitsplatte und Schublade.

Unit frame made of finest quality natural wood, with induction stove, bottle holder, sliding shelf and drawer.

Châssis en bois précieux, avec fourneau d' induction, porte-bouteilles, 2 tiroirs.

Länge length		Breite width		Höhe height		Netzspannung line voltage	
mm	in.	mm	in.	mm	in.	Volt	
1010	39 ³ / ₄	530	20 ⁷ / ₈	840	33 ¹ / ₁₆	230	30.8026.0000



PROFILE

Rinderbrustwagen, Roast beef trolley, Chariot à viande

Edelholzrahmen, ganz rollende Haube 18/10, klappbare Abstellplatte, abnehmbare Halterung für Tranchierbesteck, elektrisch beheizt.

Unit frame made of finest quality natural wood, full roll top cover 18/10, hinged side plate, removable holder for carving set, electric heating.

Châssis en bois précieux, couvercle roll-top en 18/10, tablette pliante, porte-couverts à découper, chauffage électrique.



Länge length		Breite width		Höhe height		Netzspannung line voltage	
mm	in.	mm	in.	mm	in.	Volt	
1090	42 ¹⁵ / ₁₆	620	24 ⁷ / ₁₆	1060	41 ³ / ₄	220	30.8007.0000

Länge length		Breite width		Höhe height		Netzspannung line voltage	
mm	in.	mm	in.	mm	in.	Volt	
1090	42 ¹⁵ / ₁₆	620	24 ⁷ / ₁₆	1060	41 ³ / ₄	110	30.8007.1000

PROFILE

1 Digestifaufsatz, Top for alcoholic beverages, Élément supérieur à digestifs

Länge length		Breite width		Höhe height		
mm	in.	mm	in.	mm	in.	
840	33 ¹ / ₁₆	480	18 ⁷ / ₈	245	9 ⁵ / ₈	30.8009.0010



1

2 Sorbetaufsatz, Top for sorbets, Élément supérieur à sorbets

Länge length		Breite width		Höhe height		
mm	in.	mm	in.	mm	in.	
840	33 ¹ / ₁₆	480	18 ⁷ / ₈	90	3 ⁹ / ₁₆	30.8003.0010



2

3 Kühlaufsatz mit Plexiglashaube, Top for cooling with plexiglass hood, Élément supérieur à rafraîchir avec cloche en verre plexi
Mit 6 Kühlpellets, with 6 cooling pellets, avec 6 plaque eutectique

Länge length		Breite width		Höhe height		
mm	in.	mm	in.	mm	in.	
815	32 ¹ / ₁₆	460	18 ¹ / ₈	285	11 ¹ / ₄	30.8002.0010



3

4 Käseaufsatz, Top for cheese, Élément supérieur à fromage

Länge length		Breite width		Höhe height		
mm	in.	mm	in.	mm	in.	
860	33 ⁷ / ₈	505	19 ⁷ / ₈	255	10 ¹ / ₁₆	30.8014.0010



4

5 Meeresfrüchteaufsatz, Top for seafood, Élément supérieur pour fruits de mer

Länge length		Breite width		Höhe height		
mm	in.	mm	in.	mm	in.	
820	32 ⁵ / ₁₆	460	18 ¹ / ₈	115	4 ¹ / ₂	30.8005.0010



5

6 Servierwagen - Grundmodell, Serving trolley - basic model, Chariot à service - modèle de base

Länge length		Breite width		Höhe height		
mm	in.	mm	in.	mm	in.	
1010	39 ³ / ₄	530	20 ⁷ / ₈	825	32 ¹ / ₂	30.8000.0000



6

Digestifwagen rund, Liquor trolley round, Chariot à digestifs, rond

Edelholzrahmen, Digestifaufsatz, ausziehbare Arbeitsplatte. Galerie auf Bodenplatte.

Unit frame made of finest quality natural wood, top for alcoholic beverages, sliding shelf. Gallery on the bottom shelf.

Châssis en bois précieux, élément supérieur à digestifs, tiroir, galerie sur plat en bas.



Höhe height		Ø-Außen Ø-outer		
mm	in.	mm	in.	
885	34 ¹³ / ₁₆	630	24 ¹³ / ₁₆	30.8024.1020

PROFILE

Käsewagen rund, Cheese trolley round, Chariot à fromage, rond

Edelholzrahmen, Käseaufsatz, Schneidbrett aus Kunststoff Ø 450 mm drehbar, halbrollende Plexiglashaube, ausziehbare Arbeitsplatte. Galerie auf Bodenplatte.

Unit frame made of finest quality natural wood, top for cheese, plastic cutting board Ø 17¹¹/₁₆ inch revolving, with half roll top plexiglass hood, sliding shelf. Gallery on the bottom shelf.

Châssis en bois précieux, élément supérieur à fromage, planche à couper en plastique Ø 450 mm pivotante, avec full roll-top en verre plexi, tiroir, galerie sur plat en bas.



Höhe height		Ø-Außen Ø-outer		
mm	in.	mm	in.	
1060	41 ³ / ₄	630	24 ¹³ / ₁₆	30.8024.1010

PROFILE

1 Käseaufsatz rund, Top for cheese round, Élément supérieur à fromage, rond

Schneidbrett aus Kunststoff Ø 450 mm drehbar, halbröllende Plexiglashaube.
 Plastic cutting board Ø 17¹¹/₁₆ inch revolving, with half roll top plexiglass hood.
 Planche à couper en plastique Ø 450 mm pivotante, avec cloche demi-roulante en verre plexi.

Höhe height		Ø-Außen Ø-outer		
mm	in.	mm	in.	
280	11	610	24	30.8024.0010

2 Digestifaufsatz rund, Top for alcoholic beverages round, Élément supérieur à digestifs, rond

mit Galerie, with gallery, avec galerie

Höhe height		Ø-Außen Ø-outer		
mm	in.	mm	in.	
105	4 ¹ / ₈	610	24	30.8024.0020

3 Aufsatz für Servierwagen, Top for serving trolley, Élément supérieur pour chariot à service

mit Griffen, with gripes, avec manches

Höhe height		Ø-Außen Ø-outer		
mm	in.	mm	in.	
50	1 ¹⁵ / ₁₆	610	24	30.8024.0030

4 Servierwagen rund, Serving trolley round, Chariot à service rond

Grundmodell für alle Aufsätze, Edelholzrahmen, ausziehbare Arbeitsplatte. Galerie auf Bodenplatte, Das Grundmodell ist nur mit Aufsatz verwendbar.

Basic model for all tops, unit frame made of finest quality natural wood, sliding shelf. Gallery on the bottom shelf, The basic model can only be used with a top.

Modèle de base pour tous les éléments supérieurs. Châssis en bois précieux, tiroir. Galerie sur plat en bas., Le modèle de base n'est utilisable qu'avec élément supérieur.

Höhe height		Ø-Außen Ø-outer		
mm	in.	mm	in.	
780	30 ¹¹ / ₁₆	630	24 ¹³ / ₁₆	30.8024.0000



1



2



3



4

Strahlende Optik durch die richtige Pflege
Brilliance with the right utensil care





PFLEGE · MAINTENANCE

So schön wie am ersten Tag
As nice as on the first day



REPARATURSERVICE · REPAIR SERVICE

Nutzen Sie unser Know-how. HEPP bietet Ihnen für gebrauchte und defekte Serviergeräte einen professionellen und umfangreichen Wiederaufarbeitungs-Service. So erstrahlt z.B. Ihre alte Kanne wieder in neuem Glanz.

Unsere Reparaturservice-Leistungen im Überblick:

- Schweißen und Löten von z.B. Silberkannen, Griffen und Scharnieren
- Komplette Neuversilberung von Tablett, Kannen, Leuchter, etc.
- Versilbern, Vergolden, Verkupfern, Vernickeln, Verchromen.

Haben auch Sie erhaltenswerte Lieblingsstücke, die Sie gerne wieder in frischem Glanz erstrahlen lassen wollen? Dann wenden Sie sich bitte an Ihren zuständigen HEPP-Verkaufsberater oder nehmen Sie direkt mit uns Kontakt auf:

- Telefon: +49 (0) 7231 / 4885-100
- Telefax: +49 (0) 7231 / 4885-190
- E-Mail: info@hepp.de
- www.hepp.de

Take advantage of our know-how. For used and defective serving dishes HEPP offers you a professional and extensive reprocessing service. Your old pot for example shines again in new splendour.

- Welding and soldering of handles and hinges for example
- Complete new silvering of serving trays, pots, candelabras, etc.
- silver, gold copper, nickel and chromium plating.

Do you also have favourite collectables which are worth preserving and allowing them to shine in new splendour? For any requirements please apply to your HEPP sales agent or contact us directly on

- Phone: +49 (0) 7231 / 4885-100
- Fax: +49 (0) 7231 / 4885-190
- E-Mail: info@hepp.de
- www.hepp.de



vorher · before



nachher · after

Pflege · Maintenance

Besteckaufbereitung · Cutlery preparation

Ein gutes Besteck kann Sie über lange Zeit erfreuen. Damit das auch so bleibt, bietet HEPP Ihnen einen fachmännischen Aufarbeitungs-Service, der Ihr altes Besteck wieder so schön aussehen lässt, wie am ersten Tag.

Oberflächenbearbeitung von Bestecken:

- Polieren, Mattieren und Sandstrahlen
- Erneuerung des Wellenschliffs bei Messern
- Laserkennzeichnung, Stempelung, Gravuren sowie Ätzung von Bestecken.

Good cutlery can please you a long time. For all to remain in such a way, HEPP offers a competent professional processing service which allows your old cutlery to look as nice as on the first day.

Processing of the surface of cutlery:

- Polishing, mat finishing or sandblasting
- Renewal of serrated knives
- Labelling with laser, stamping, engraving as well as etching of cutlery.

Aufarbeitung · Refurbishment

Aus alt mach neu – HEPP ist nicht nur ein Anbieter qualitativ hochwertigster Produkte für den gedeckten Tisch und das Buffet, sondern bietet Ihnen auch den einzigartigen Service, Ihre Produkte zu reparieren und aufzufrischen.

Oberflächenbearbeitung von Serviergeräten / Bestecken:

- Ausbeulen und Planieren
- Polieren, Mattieren oder Sandstrahlen
- Ver- und Bearbeitung von Edelstahl, Messing, Neusilber, etc.

Make new from old – HEPP is not only a supplier of high-class quality products for the table and the buffet but also offers a unique service to repair and polish up your products.

Processing of the surface of serving dishes and cutlery:

- Flattening and planishing
- Polishing, mat finishing or sandblasting
- Machining and processing of high quality steel, brass, new silver, etc.



Besteckaufbereitung · Cutlery preparation



Aufarbeitung · Refurbishment



Reparaturservice · Repair service



Polieren · Polishing



Messerklingschutz · Knife blade protector



Abteilverrichtung · Compartment section



Goliath 2000 Type C

75.9201.0010

Mit dieser Maschine werden Bestecke und Serviergeräte mühelos und ohne jegliche Abnutzung der Feinsilberauflage poliert. Bei jedem Poliervorgang wird die Auflage neu gehärtet und verdichtet. Es ergibt sich eine problemlose Grundreinigung, und die Lebensdauer der Feinsilberauflage wird wesentlich verlängert. Durch ein offenes Trogsystem kann die Maschine bei laufendem Poliervorgang bestückt bzw. das Poliergut entnommen werden.

Die kompakte Bauweise mit ihrer 56 cm-Frontbreite findet in jeder Küche Platz. Die Steuerelemente sind komplett versenkt und ergonomisch im 40°-Winkel angeordnet.

- Ein Poliervorgang ca. 3 Minuten
- Fassungsvermögen ca. 30 Besteckteile, sortiert in Löffel oder Gabeln, Messer nur mit Messerpoliervorrichtung. Serviergeräte wie z.B. Saucieren, Schüsseln, Weinkühler und Platten bis 30 cm Ø oder 30 x 42 cm.
- Polieren ohne Abteilverrichtung: z.B. 1 Weinkühler
- Polieren mit Abteilverrichtung: z.B. 3 Platzteller

Bitte beachten Sie die gesonderte Betriebsanleitung des Herstellers für die Maschine.

Standardmäßig ausgerüstet mit einem Sammel-Drehkorb. Die Bestecke werden beim Entnehmen sofort von den Polierkugeln getrennt. Dadurch Verdreifachung der Polierkapazität. Die Bandgeschwindigkeit ist wählbar zwischen Normalgeschwindigkeit für Dauerbetrieb sowie langsame Drehzahl für das Positionieren des Sammelkorbes oder das Polieren von großen Teilen.

Für die periodische Reinigung lässt sich die gesamte horizontale Verschalung von der Maschine in einem Handgriff ohne Werkzeug entfernen. Dadurch lässt sich die Außenwanne jederzeit ausspülen, ohne dass die Polierkugeln entfernt werden müssen, und die Maschine bietet im Bedarfsfall sofortigen Zugang zur Steuerung oder zum Antrieb. Ein Sicherheitsschalter unterbricht den Stromkreislauf sofort, sobald die Abdeckung entfernt wird. Die Kraftübertragung per Keilriemen ist zuverlässig, sparsam im Stromverbrauch und sehr unterhaltsfreundlich (kein Getriebe = keine periodische Schmierung!).



Technische Daten

Bandgeschwindigkeit:	einstellbar 40 cm oder 20 cm/sec.
Größe Poliertrog:	Ø 31 x 43 cm
Chassis in Edelstahl:	fahrbar mit Radstopper
Gehäuse:	Chromnickelstahl mattiert
Steuerung:	Kombischalter 1-0-30 Min. Schaltuhr, Wahlschalter für Geschwindigkeit
Anschlusswert:	3 x 400 V~max. 330 W, 50 oder 60 Hz
Ablaufhahn:	Ø 1" (Nennwert 25 mm)
Abmessungen:	560 x 715 x 900 mm
Gewicht:	83 kg + 70 kg Polierstahlkugeln
Zubehör:	70 kg Polierstahlkugeln, 1 Abteilverrichtung (teilt den Poliertrog in drei Fächer) 5 Messerklingschutz (schützende Klinge beim Polieren) inkl. Halter 1 Sammel-Korb Typ 20 (17 x 17 mm Maschenweite)

Technische Änderungen und Verbesserungen vorbehalten

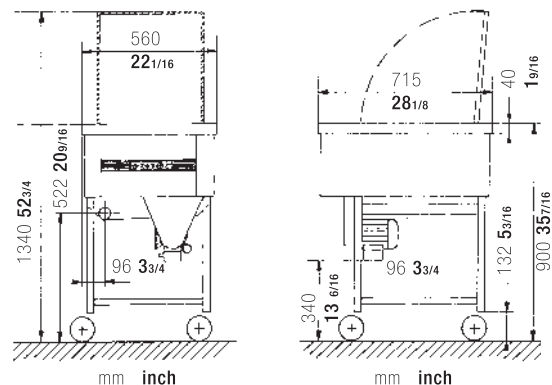

Goliath 2000 Type C

75.9201.0010

The machine is used to polish cutlery and serving equipment without damaging the fine silver plating. The plating is rehardened and compacted during every polishing. This results in a problemfree basic cleaning and the service life of the fine silver plating is significantly prolonged. Thanks to an open trough system the machine can be filled and emptied with cutlery, etc., during polishing.

The compact design, with a front width of just 22¹/₁₆ inch, means that it can fit into any kitchen. The control switches are fully recessed and arranged ergonomically at an angle of 40°.

- Polishing takes approx. 3 minutes
- Capacity approx. 30 pieces of cutlery, sorted as spoons or forks, knives only with knife polishing devices. Serving equipment such as gravy boats, dishes, wine coolers and trays up to 11¹³/₁₆ inch Ø or 11¹³/₁₆ x 16⁹/₁₆ inch.
Polishing without compartmenting device: e.g. 1 wine cooler
Polishing with compartmenting device: e.g. 3 service plates

Please pay attention to the operating instructions provided by the machine's manufacturer.

Standard equipment includes a rotary basket. The cutlery is immediately separated from the polishing balls on removal of this basket. This triples the polishing capacity.

The belt has two speeds. The standard speed is for normal operation and the reduced speed for positioning the basket or polishing larger items.

The entire horizontal casing can be easily removed from the machine without tools for periodic cleaning. The outer tank can thus be rinsed at any time without having to remove the polishing balls. The machine also offers immediate access to the electrical controls and drive components as required. A safety switch immediately interrupts the power supply as soon as the casing is removed. The power transmission via the V-belt is reliable, economical and requires little or no maintenance (no gears = no periodic lubrication!).

Technical data

Belt speed:	adjustable 15 ³ / ₄ inch or 7 ⁷ / ₈ inch/sec
Size of polishing trough:	Ø 12 ³ / ₁₆ x 16 ¹⁵ / ₁₆ inch
*Chassis:	moveable with wheel brake
Casing:	stainless steel (mat)
Control system:	Combi- switch 1-0-30 minute timer, 2- speed switch
Connected load:	3 x 400 V-max. 330 W, 50 or 60 cycles
Drainage tap:	Ø 1" (nominal value 1 inch)
Dimensions:	22 ¹ / ₁₆ x 28 ¹ / ₈ x 35 ⁷ / ₁₆ inch;
Weight:	2669 oz + 2251 oz polishing steel balls
Accessoires:	2251 oz polishing steel balls
	1 compartmenting device (divides polishing through into 3 compartments)
	5 knife blade protectors (protect blades during polishing)
	including holder, 1 Type 20 sorting basket (1 ¹ / ₁₆ x 1 ¹ / ₁₆ inch mesh width)

Subject to technical changes and improvements

*= stainless steel

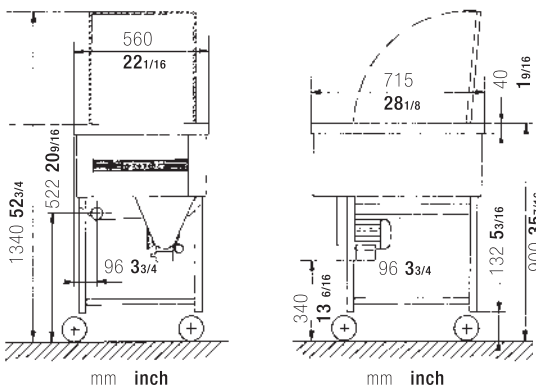

Goliath 2000 Type C

75.9201.0010

Polit les couverts et les ustensiles de service sans faigue et sans les user. Durcit l'argent et accroît sa „durabilité“. Pas de tambour de polissage. Utilisation simple grâce au système de „baquet“ ouvert. La masse de billes d'acier est mise en mouvement par un tapis roulant. Grâce au fonctionnement „non stop“ la machine peut être remplie et vidée sans interrompre le processus de polissage: gain de temps.

La construction compacte avec une largeur frontale de 56 cm (!) seulement passe partout et trouve place dans toute cuisine. Le tableau de bord est enfoncé complètement dans un angle anatomique de 40°.

- Pour un cycle de polissage il faut environ 3 minutes
- Capacité environ 30 pièces de couverts, rangés en cuillers ou fourchettes, veuillez mettre les couteaux dans les manches de protection.
Ustensiles à servir comme par exemple des saucières, plats creux, seaux à vin et plateaux jusqu'au 30 cm Ø ou 30 x 42 cm.
Polissage sans dispositif à séparation: par exemple 1 seau à vin.
Polissage avec dispositif à séparation: par exemple 3 assiettes spéciales

Veillez suivre le mode d'emploi séparé du fabricant de la machine.

Equipé d'un panier de triage pour récupérer les couverts de table et d'autres petits objets en une seule opération. La machine est ainsi vidée rapidement et toute de suite prête pour être rechargée. La vitesse du tapis d'entraînement est ajustable entre vitesse rapide pour le polissage et vitesse réduite pour faire demi tour du panier de triage ou pour polir des objets volumineux.

La couverture horizontale de la machine peut être enlevée sans outil pour un nettoyage périodique ou un accès immédiat à la transmission. Il est ainsi possible de rincer la cuve extérieure sans enlever les billes à polir. Pour sécurité, le courant électrique est interrompu immédiatement en cas d'ouverture de la cage. La transmission simple par courroies trapézoïdales est sûre et ne demande aucun entretien (pas d'engrenages = pas de lubrification périodique!).

Caractéristiques techniques

Vitesse du tapis:	ajustable 40 cm ou 20 cm/sec.
Bassin à polir	Ø 31 x 43 cm
Châssis:	en acier inoxydable, sur roulettes avec frein
Boîte extérieure:	en acier inoxydable brossé
Commande:	Interrupteur 0 à 30 minutes ou sans arrêt bouton pour régler la vitesse du tapis
Branchement:	3 x 400/415 V - max. 330 W 50 ou 60 p
Robinet d'écoulement:	Ø 1" (DN 25 mm)
Poids net:	env. 83 kg machine + 70 kg de billes à polir
Equipement standard:	70 kg billes acier au carbone* Ø 3/16" trempé *(acier inox AISI 420 contre supplément) 1 dispositif de séparation (divise le byc en trois compartiments) 5 dispositifs à polir les couteaux 1 panier de triage

Sous réserve des modifications techniques.

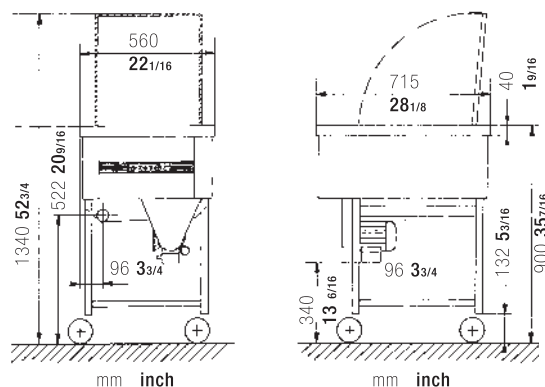

Goliath 2000 Type B

75.9200.0000

Mit dieser Maschine werden Bestecke und Serviergeräte mühelos und ohne jegliche Abnutzung der Feinsilberauflage poliert. Bei jedem Poliervorgang wird die Auflage neu gehärtet und verdichtet. Es ergibt sich eine problemlose Grundreinigung, und die Lebensdauer der Feinsilberauflage wird wesentlich verlängert. Durch ein offenes Trogsystem kann die Maschine bei laufendem Poliervorgang bestückt bzw. das Poliergut entnommen werden.

- Ein Poliervorgang ca. 3 Minuten
- Fassungsvermögen ca. 30 Besteckteile, sortiert in Löffel oder Gabeln, Messer nur mit Messerpoliervorrichtung. Serviergeräte wie z.B. Saucieren, Schüsseln, Weinkühler und Platten bis 30 cm Ø oder 30 x 42 cm.
Polieren ohne Abteilverrichtung: z.B. 1 Weinkühler
Polieren mit Abteilverrichtung: z.B. 3 Platzteller

Bitte beachten Sie die gesonderte Betriebsanleitung des Herstellers für die Maschine.

Für die periodische Reinigung lässt sich die gesamte horizontale Verschaltung von der Maschine in einem Handgriff ohne Werkzeug entfernen. Dadurch lässt sich die Außenwanne jederzeit ausspülen, ohne dass die Polierkugeln entfernt werden müssen, und die Maschine bietet im Bedarfsfall sofortigen Zugang zur Steuerung oder zum Antrieb. Ein Sicherheitsschalter unterbricht den Stromkreislauf sofort, sobald die Abdeckung entfernt wird. Die Kraftübertragung per Keilriemen ist zuverlässig, sparsam im Stromverbrauch und sehr unterhaltsfreundlich (kein Getriebe = keine periodische Schmierung!). Goliath 2000 Type B hat eine konstante Drehzahl und ist mit einem Einphasen- Motor ausgerüstet.



Technische Daten

Bandgeschwindigkeit:	konstant 40 cm
Größe Poliertrog:	Ø 31 x 43 cm
Chassis in Edelstahl:	fahrbar mit Radstopper
Gehäuse:	Chromnickelstahl gebürstet
Steuerung:	Kombischalter 1-0-30 Min. Schaltuhr, oder non stop
Anschlusswert:	1 x 230/240 V--max. 330 W, 50 oder 60 Hz
Ablaufhahn:	Ø 1" (Nennwert 25 mm)
Gewicht:	81 kg + 70 kg Polierstahlkugeln
Zubehör:	70 kg Polierstahlkugeln, 1 Abteilverrichtung (teilt den Poliertrog in drei Fächer) 5 Messerklingenschutz (schützen die Klinge beim Polieren)

Technische Änderungen und Verbesserungen vorbehalten

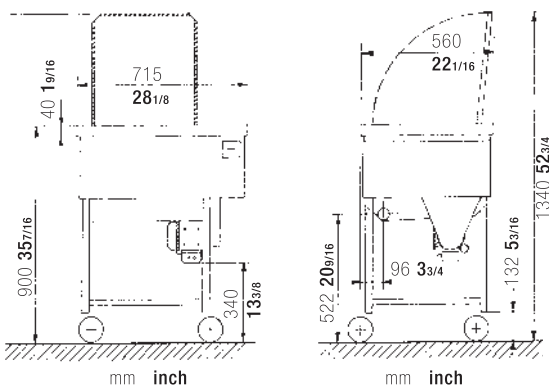

Goliath 2000 Type B

75.9200.0000

The machine is used to polish cutlery and serving equipment without damaging the fine silver plating. The plating is rehardened and compacted during every polishing. This results in a problemfree basic cleaning and the service life of the fine silver plating is significantly prolonged. Thanks to an open trough system the machine can be filled and emptied with cutlery, etc., during polishing.

- Polishing takes approx. 3 minutes
- Capacity approx. 30 pieces of cutlery, sorted as spoons or forks, knives only with knife polishing devices. Serving equipment such as gravy boats, dishes, wine coolers and trays up to 11¹³/₁₆ inch Ø or 11¹³/₁₆ x 16⁹/₁₆ inch.
Polishing without compartmenting device: e.g. 1 wine cooler
Polishing with compartmenting device: e.g. 3 service plates

Please pay attention to the operating instructions provided by the machine's manufacturer.

The entire horizontal casing can be easily removed from the machine without tools for periodic cleaning. The outer tank can thus be rinsed at any time without having to remove the polishing balls. The machine also offers immediate access to the electrical controls and drive components as required. A safety switch immediately interrupts the power supply as soon as the casing is removed. The power transmission via the V-belt is reliable, economical and requires little or no maintenance (no gears = no periodic lubrication!).

Goliath 2000 Type B runs at a constant speed and is equipped with a single-phase motor.

Technical data

Belt speed:	constant 15 ³ / ₄ inch/sec
Size of polishing trough:	Ø 12 ³ / ₁₆ x 16 ¹⁵ / ₁₆ inch
Chassis:	Stainless steel mobile with wheel-stoppers
Casing:	stainless steel (mat)
Controls:	Combi- switch for 30 minutes or non-stop
Electrical data:	1 x 230/240 V-330 W, 50 or 60 cycles
Drainage tap:	Ø 1" (nominal value 1 inch)
Weight:	approx. 2604 oz machine+ 2251 oz polishing balls
Accessoires:	2604 oz polishing steel balls, 1 compartmenting device (divides polishing through into 3 compartments) 5 knife bladeprotectors (protect blades during polishing)

Subject to technical changes and improvements

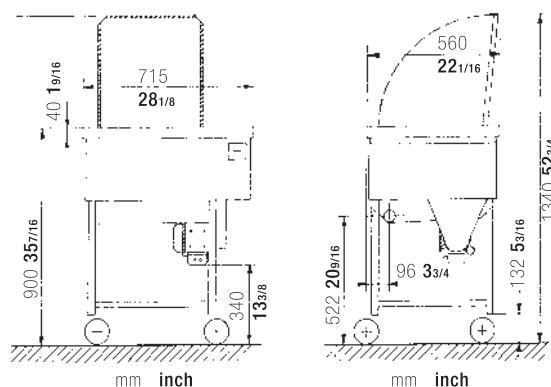

Goliath 2000 Type B

75.9200.0000

Polit les couverts et les ustensiles de service sans faigue et sans les user. Durcit l'argent et accroît sa „durabilité“. Pas de tambour de polissage. Utilisation simple grâce au système de „baquet“ ouvert. La masse de billes d'acier est mise en mouvement par un tapis roulant. Grâce au fonctionnement „non stop“ la machine peut être remplie et vidée sans interrompre le processus de polissage: gain de temps.

La construction compacte avec une largeur frontale de 56 cm (!) seulement passe partout et trouve place dans toute cuisine. Le tableau de bord est enfoncé complètement dans un angle anatomique de 40°.

- Pour un cycle de polissage il faut environ 3 minutes
- Capacité environ 30 pièces de couverts, rangés en cuillers ou fourchettes, veuillez mettre les couteaux dans les manches de protection.
Ustensiles à servir comme par exemple des saucières, plats creux, seaux à vin et plateaux jusqu'au 30 cm Ø ou 30 x 42 cm.
Polissage sans dispositif à séparation: par exemple 1 seau à vin.
Polissage avec dispositif à séparation: par exemple 3 assiettes spéciales

Veuillez suivre le mode d'emploi séparé du fabricant de la machine.

La couverture horizontale de la machine peut être enlevée sans outil pour un nettoyage périodique ou un accès immédiat à la transmission. Il est ainsi possible de rincer la cuve extérieure sans enlever les billes à polir. Pour sécurité, le courant électrique est interrompu immédiatement en cas d'ouverture de la cage. La transmission simple par courroies trapézoïdales est sûre et ne demande aucun entretien (pas d'engrenages = pas de lubrification périodique!).

Goliath 2000 Type B a une vitesse de rotation constante et est équipé d'un moteur monophasé.

Caractéristiques techniques

Vitesse du tapis:	ajustable 40 cm/sec.
Bassin à polir:	Ø 31 x 43 cm
Châssis:	en acier inoxydable, sur roulettes avec frein
Boîte extérieure:	en acier inoxydable brossé
Commande:	Interrupteur 0 à 30 minutes ou sans arrêt
Branchement:	1 x 230/240 V ~ 330 W 50 ou 60 p
Robinet d'écoulement:	Ø 1" (DN 25 mm)
Poids net:	env. 81 kg machine + 70 kg de billes à polir
Équipement standard:	70 kg billes de polissage en acier 1 dispositif de séparation (divise le bac en trois compartiments) 5 manches de protection pour couteaux (protège les lames en polissant)

Sous réserve des modifications techniques.

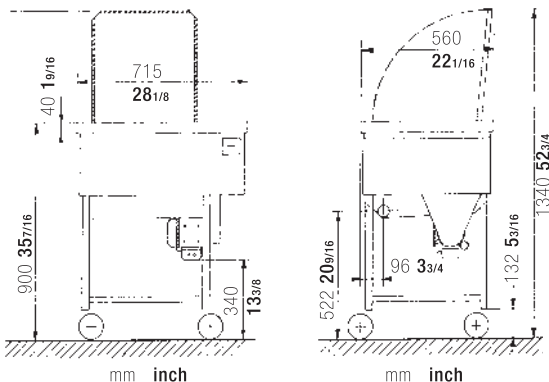



Silber-Polish, Silver-Polish, Polish argenté

Seifenpulver für Silberpoliermaschine Goliath 2000, vermeidet Rückstände, schont Maschine und Förderband.

Soap powder for Silver Burnishing Machine Goliath 2000. Prevents formation of residues, treats machine and conveyor belt carefully.

Poudre d'entretien pour machine à polir Goliath 2000, dissout les impuretés protège la machine et le tapis roulant.

Inhalt
cap.

Ltr.	oz.	
8,00 kg	257	75.9205.0000



NEUTRAL

Silberpflegemittel, Silver care product, Produit de nettoyage pour l'argenterie
für Silber, Messing und Kupfer, geeignet für leichten bis mäßigen Anlauf, enthält Wiederanlauf-Schutz.

for silver, brass and copper, suitable for slight to moderate tarnish, contains anti-tarnish protection.

pour argent, laiton et cuivre, adapté pour ternissement léger ou modéré; contient une protection anti-ternissement.

Inhalt
cap.

Ltr.	oz.	
1,00	35	57.0175.9990



NEUTRAL

HEPPOLIT-Silberreinigungspulver, HEPPOLIT-Silver Cleaning Powder, Poudre de nettoyage pour l'argenterie HEPPOLIT

nur wirksam in Verbindung mit HEPP-Silberreinigungsapparat oder HEPP-Silberreinigungsplatten. 1 Esslöffel HEPPOLIT in 1 Liter heißem Wasser auflösen, Silbergegenstände 2 Minuten in dieser Lauge liegen lassen, spülen.

effective only in combination with the HEPP Silver Cleaning Apparatus or HEPP Silver Cleaning Plates. Dissolve 1 table spoon of HEPPOLIT in 1 litre of hot water, leave silver articles for 2 minutes in this solution, rinse.

a n'utiliser qu'avec l'appareil de nettoyage HEPP ou les plaques de nettoyage HEPP. Dissoudre une cuillère à soupe de poudre par litre d'eau très chaude et laisser tremper les objets dans ce bain pendant 2 minutes, rincer.

Inhalt
cap.

Ltr.	oz.	
5,00 kg	161	75.9211.0000



NEUTRAL

HEPP-Silberreinigungsapparat, HEPP-Silver Cleaning Apparatus, Appareil à nettoyer l'argenterie HEPP

mit Aluminium-Einsatz, das ideale Gerät für einfache Silberpflege. Silbergegenstände trocken einlegen, heißes Wasser mit je 1 Esslöffel HEPPOLIT Reinigungspulver pro Liter hinzugeben, Silbergegenstände 2 Minuten liegen lassen, herausnehmen, nachspülen, nach Silberreinigung Aluminium-Einsatz vom Schmutz befreien.

with aluminum insert - the ideal appliance for simple silver care. Put in silver articles dry, add hot water together with 1 table spoon of HEPPOLIT Cleaning Powder for each litre. Leave silver articles in this solution for 2 minutes, then take them out and rinse. After silver cleaning remove dirt from aluminium insert.

avec bac en aluminium. Appareil idéal pour l'entretien courant de l'argent. Disposer les objets en argent secs dans l'appareil, ajouter de l'eau très chaude avec une cuillère à soupe de poudre „Heppolit“ par litre; laisser les objets en argent dans cette solution pendant 2 minutes, les sortir, les rincer. A la fin du nettoyage, veiller à garder la garniture en aluminium très propre.



Inhalt	Länge	Breite	Höhe	Aluminium	Zink und Aluminium				
cap.	length	width	height	aluminium	zinc coated and aluminium				
Ltr.	oz.	mm	in.	mm	in.				
1	55,0	1937	633	24 ¹⁵ / ₁₆	428	16 ⁷ / ₈	224	8 ¹³ / ₁₆	75.9207.0000
2	55,0	1937	620	24 ⁷ / ₁₆	400	15 ³ / ₄	200	7 ⁷ / ₈	75.9208.0000

NEUTRAL

HEPP-Silberreinigungsplatten, HEPP-Silver cleaning plates, Plaques HEPP pour le nettoyage de l'argenterie

aus Aluminium, empfehlenswert für Hepp-Silberreinigungsapparat. Kann auch in Kunststoffbecken eingelegt werden.

of aluminum, recommendable for Hepp Silver Cleaning Apparatus. Can also be put into plastic basins.

plaques en aluminium, recommandable pour l'appareil à nettoyer l'argenterie Hepp. Peuvent également être mises dans des bacs en plastique.

Inhalt	Aluminium	
cap.	aluminium	
Ltr.	oz.	
1 Packung mit 10 Platten	1 package with 10 plates	75.9210.0000



NEUTRAL



Artikel	Seite	Artikel	Seite
A bedeckhaube	171	Essig- / Ölfflasche	115
Accent	44-45	Essig-Ölgestell	115
Afternoon Tea Etagere	96-97	Etagere	175
Aufsatz für Servierwagen	212, 221	Exclusiv	50-51
Aura	28-29	F assung	179
Ausstellplatte	166-168, 171	Fingerschale	113
Austerngestell	113	Flaschen-Gläserteller	195
B aguette	20-21	Flaschenkühler mattiert	187
Bankett-Leuchter	121	Flaschenträger für 6 Flaschen	204
Barstände	193-194	G abel	179
Behälter für Cerealien dispenser	68	Gebäckständer	92-93
Besteckablage	148	Gebäckzange	59
Besteckständer	61	Gemüselöffel	57
Blumenvase	124-125	Gemüseschüssel	101
Bowlenöffel	58	Glasbecher	179
Brennerdose	78, 164	Glaseinsatz	73, 87-90, 114, 119, 174
Brennerhalter	150, 163	Glaseinsatz für Essig-Ölgestell	115
Brötchenmesser	60	Glaskrug	73
Brotkorb	90, 111-112	Goliath 2000 Type B	230-232
Brotkorb L	140	Goliath 2000 Type C	227-229
Brotkorb M	140	H EPPOLIT-Silberreinigungspulver	233
Brotkorb S	140	HEPP-Silberreinigungsapparat	234
Buffetgestell GN 2/3	145-146	HEPP-Silberreinigungsplatten	234
Buffetgestell rund	144-145	Holzschale „M“	110
Buffetpräsentier	180	Holzschale „S“	110
Buffetständer „L“	173, 195	Honig-Konfitürendose	89-90
Buffetständer „M“	173, 195	Humidorwagen	205, 215
Buffetständer „S“	173, 194	Hummergabel	59
Butterdose	104-106	Hummerzange	59
C arlton	26-27	I nduktionswagen	208, 217
Cerealien dispenser drehbar	67	Isolierkanne	85
Cerealien dispenser Reihenlösung	67-68	K affeekanne	79-83
Chafing Dish	159	Kaffeelöffel	61
Chafing Dish GN 1/1	151-154, 156-158	Kanne mit Deckel	70
Chafing Dish Haube GN 1/1	159	Käseaufsatz	210, 219
Chafing Dish Induktion GN 2/3	143-144	Käseaufsatz rund	212, 221
Chafing Dish Induktion rund	143	Käsedose	119
Chafing Dish Ø 24 cm	152	Käsemesser	58
Chafing Dish Ø 30 cm	151-153, 155	Käsewagen	207, 216
Chafing Dish Ø 40 cm	151, 153-156	Käsewagen rund	211, 220
Chafing Dish Wagen	208	Kaviarmesser	60
Champagnerkühler	184	Kaviarschaufel	60
Champagnerschüssel	189	Kerzenleuchter	123
Chillcup	114	Klapphaube	158
Chippendale	46-47	Kreuzband	34-35
Coffee Urn	75-77	Krümelsammler	59, 106
Contour	24-25	Krümelschaufel	59, 106
D eckel	101-102	Kuchen- und Nachspeisenwagen	206, 216
Deckel für Champagnerkühler	184	Kuchengabel	61
Deckel mit Ausschnitt	79	Kugelglocke	100-101
Deckel mit Einschnitt	102	Kühlakku	170
Diamond	42-43	Kühlaufsatz mit Plexiglashaube	210, 219
Digestifaufsatz	210, 219	Kühlpellet	73
Digestifaufsatz mit Glashalter	210	L ento	32-33
Digestifaufsatz rund	212, 221	Leuchter	120-122
Digestifwagen	203, 214	Löffel	179
Digestifwagen rund	211, 220	M edan	40-41
Dressinglöffel	57	Meeresfrüchteaufsatz	210, 219
E cco	22-23	Meeresfrüchtewagen	207, 217
Eierbecher	90	Menage	70, 118
Einsatz für Chafing Dish	148, 157, 160, 162-163	Menü gabel	61
Eisbecher	108	Menü löffel	61
Eisröhre	66	Menü messer	61
Eisschale	108	Milch- und Sahnebehälter	79
Eiswanne GN 1/1	140	Milchdispenser	65
Eiswanne L	140	Milchkanne	80-84
Eiswanne M	140	N ichtraucherschild	127
Eiswasserkanne	190-191		
Elektroheizung	77, 150, 164-165		
Elektroheizung regelbar	150, 164		
Emotion	48-49		



Artikel	Seite	Artikel	Seite
Nußknacker	59	Senfgefäß	118
O bstkorb	91	Servier- und Menagentablett „M“	109
Obstschale	175	Servier- und Menagentablett „S“	109
P artum	16-17	Servierplatte	104
Party-Löffel	58	Servierschüssel	102
Pfeffermühle	116	Serviertablett	91, 113, 166
Pfefferstreuer	116-117	Servierwagen - Grundmodell	205, 210, 219
Pizza/Steakmesser	60	Servierwagen rund	212, 221
Platte GN 1/1 CORIAN®	139	Silberpflegemittel	233
Platte GN 1/1 Eiche	139	Silber-Polish	233
Platte L CORIAN®	139	Sorbetaufsatz	210, 219
Platte L Eiche	139	Sorbetbehälter	108
Plattenständer hoch	170	Sorbetwagen	203, 215
Plattenständer tief	170	Spaghettizange	56
Platzteller	100	Ständer für Champagnerkühler	187
Plexiglashaube	169	Ständer für Konfitürengläser	89
Podestfüße M	141	Steakhaus-Gabel	58
Podestfüße S	141	Steakhaus-Messer	58
Podestplatte M	141	Steg	163
Podestplatte M Eiche	141	Style	38-39
Podestplatte S	141	Suppenmarmite	158
Podestplatte S Eiche	141	Suppenschöpfer	57, 149
Portionsschöpfer	57	Suppenschüssel	102
Porzellanbecher	179	Suppenstation	146, 157-159
Porzellan-Einsatz	73, 105, 138, 147, 161-162, 171, 174	T alia	36-37
Porzellanschale „M“	110	Teekanne	79-80, 82-84
Porzellanschale „S“	110	Teesieb	85
Porzellanschale „S“ flach mit 3-Teilung	109	Tellerglocke	176
Porzellanschale für Besteckablage	148	Tischlicht/ Teelichthalter	124
Porzellanschale L 35	138	Tischnummer	126
Porzellanschale L 65	138	Tischnummernschild	127
Porzellanschale M 35	137	Tischnummernständer	126
Porzellanschale M 65	137	Tischpräseniter	180
Porzellanschale S 35	137	Toastständer	90
Porzellanschale S 65	137	Tortenheber	58
Porzellanschale XS 35	136	Tortennmesser	58, 93
Porzellanschale XS 65	136	Tortennmesserbehälter	93
Premium	52-53	Tortenplatte	93
Profile	18-19	Tranchiergabel	57
R ahmen GN 1/1 100	136	Tranchiermesser	57
Rahmen GN 1/1 40	136	Transportgestell	66
Rahmen GN 1/1 70	136	Traubenschere	59
Rahmen L 100	135	Trend	54-55
Rahmen L 40	135	U niversal-Löffel-Gabel	58
Rahmen L 70	135	Universalschale	74, 175
Rahmen M 100	135	Universalständer	72, 94, 107, 174
Rahmen M 40	135	Universalzange	56
Rahmen M 70	135	Unterteller	104, 113
Rahmen S 100	134	V orlegegabel	56-57, 149
Rahmen S 40	134	Vorlegegabel für Chafing Dish	56
Rahmen S 70	134	Vorlegelöffel	56, 149
Rahmen XS 100	134	Vorlegelöffel für Chafing Dish	56
Rahmen XS 40	134	W andhalterung doppelt	69
Rahmen XS 70	134	Wandhalterung einfach	69
Reservierschild	127	Warmhaltebox	213
Rinderbrustwagen	209, 218	Weinkühler	184-186
Roheisbehälter	191-192	Weinkühlerständer	187-188
Roheisschaufel	193	Weinwagen	204
Roheiszange	193	Windlicht	122-123
Rondell	71	Z ahnstocherbehälter	119, 195
Roomservicewagen	213	Zange	56, 149
Rotweingestell	188	Zigarrenabschneider	193
Rotweinkorb	189	Zitronenpresse	85
Royal	30-31	Zuckerbehälter	79
S aftdispenser	64	Zuckerbox	85
Saftständer	72	Zuckerdose	80-84
Salatzange	56	Zuckerständer	87-88
Salzmühle	116	Zuckerzange	59
Salzstreuer	116-117		
Saucenlöffel	57		
Sauciere	103		

Article	Page	Article	Page
A ccent	44-45	E cco	22-23
Afternoon Tea stand	96-97	Egg cup	90
All purpose bowl	74, 175	Emotion	48-49
All purpose tongs	56	Etagere	175
Aura	28-29	Exclusiv	50-51
B aguette	20-21	F inger bowl	113
Banquet tray	166-168, 171	Flap rolltop cover	158
Bottle and glass tray	195	Fork	179
Bottle-cooler satin finished	187	Frame	179
Bread basket	90, 111-112	Frame GN 1/1 100	136
Bread basket L	140	Frame GN 1/1 40	136
Bread basket M	140	Frame GN 1/1 70	136
Bread basket S	140	Frame L 100	135
Buffet stand „L“	173, 195	Frame L 40	135
Buffet stand „M“	173, 195	Frame L 70	135
Buffet stand „S“	173, 194	Frame M 100	135
Buffet stand GN 2/3	145-146	Frame M 40	135
Buffet stand round	144-145	Frame M 70	135
Burner holder	150, 163	Frame S 100	134
Burner tin	78, 164	Frame S 40	134
Butter dish	104-106	Frame XS 100	134
		Frame XS 40	134
		Frame XS 70	134
C ake fork	61	Fruit basket	91
Cake knife	58, 93	Fruit bowl	175
Cake knife stand	93		
Cake plate	93	G las insert	87-90, 119
Cake server	58	Glass cup	179
Candelabra	120-122	Glass insert	73, 114, 174
Candelabra for banquet	121	Glass insert for vinegar and oil stand	115
Candle holder	122-123	Glass jug	73
Candle lamp	122-123	Goliath 2000 Type B	230-232
Carlton	26-27	Goliath 2000 Type C	227-229
Carousel	71	Grape scissors	59
Carving fork	57		
Carving knife	57	H eating element	77, 150, 164-165
Caviar knife	60	Heating element adjustable	150, 164
Caviar spoon	60	HEPPOLIT-Silver Cleaning Powder	233
Cereal dispenser in-line	67-68	HEPP-Silver Cleaning Apparatus	234
Cereal dispenser rotatable	67	HEPP-Silver cleaning plates	234
Chafing Dish	159	Holder for 6 bottles	204
Chafing Dish cover GN 1/1	159		
Chafing Dish GN 1/1	151-154, 156-158	I ce bucket	191-192
Chafing Dish Induction GN 2/3	143-144	Ice cream bowl	108
Chafing Dish Induction round	143	Ice cream cup	108
Chafing Dish Ø 24 cm	152	Ice pack	170
Chafing Dish Ø 30 cm	151-153, 155	Ice shovel	193
Chafing Dish Ø 40 cm	151, 153-156	Ice tongs	193
Chafing Dish trolley	208	Ice tray GN 1/1	140
Champagne bowl	189	Ice tray L	140
Champagne cooler	184	Ice tray M	140
Cheese dish	119	Ice tube	66
Cheese knife	58	Ice water pitcher	191
Cheese trolley	207, 216	Induction trolley	208, 217
Cheese trolley round	211, 220	Insert for Chafing Dish	148, 157, 160, 162-163
Chillcup	114	Insulated beverage server	85
Chippendale	46-47		
Cigar cutter	193	J am/honey pot	89-90
Cigar trolley	205, 215	Jug with lid	70
Coffee pot	79-83	Juice dispenser	64
Coffee spoon	61	Juice stand	72
Coffee Urn	75-77		
Comb. Spoon-Fork	58	K reuzband	34-35
Container for cereal dispenser	68		
Contour	24-25	L emon squeezer	85
Cooling pellet	73	Lento	32-33
Cover	176	Lid	101-102
Cover for trays	171	Lid for champagne cooler	184
Cruet stand	118	Lid with cut-out	79
Crumb scraper	59, 106	Lid with hole	102
Cutlery holder	61	Liquor trolley	203, 214
		Liquor trolley round	211, 220
D iamond	42-43	Lobster crack	59
Dome cover	100-101	Lobster fork	59
Dressing spoon	57		

Article	Page	Article	Page
M edan	40-41	Serving trolley round	212, 221
Milk dispenser	65	Show plate	100
Milk jug	79-84	Silver care product	233
Multi purpose stand	72, 94, 107, 174	Silver-Polish	233
Mustard pot	118	Snack stand	193-194
No Smoking sign	127	Sorbet pot	108
Nut cracker	59	Sorbet trolley	203, 215
O yster rack	113	Soup ladle, large	57, 149
P artum	16-17	Soup ladle, small	57
Party spoon	58	Soup marmite	158
Pastry and dessert trolley	206, 216	Soup Station	146, 157-159
Pastry stand	92-93	Soup tureen	102
Pastry tongs	59	Spaghetti tongs	56
Pedestal feet M	141	Spoon	179
Pedestal feet S	141	Stand for champagne cooler	187
Pedestal plate M	141	Stand for jam glasses	89
Pedestal plate M oak	141	Stand for wine cooler	187-188
Pedestal plate S	141	Steakhouse fork	58
Pedestal plate S oak	141	Steakhouse knife	58
Pepper mill	116	Strut	163
Pepper shaker	116-117	Style	38-39
Pizza/Steak knife	60	Sugar bowl	79-84
Plate GN 1/1 CORIAN®	139	Sugar box	85
Plate GN 1/1 oak	139	Sugar server	87-88
Plate L CORIAN®	139	Sugar tongs	59
Plate L oak	139	T able crumbler	59, 106
Plexiglass hood	169	Table fork	61
Porcelain bowl for rack for utensils	148	Table knife	61
Porcelain cup	179	Table number	126
Porcelain dish „M“	110	Table number sign	127
Porcelain dish „S“	110	Table number stand	126
Porcelain dish „S“ with 3 divisions	109	Table spoon	61
Porcelain dish L 35	138	Talia	36-37
Porcelain dish M 35	137	tea light holder	124
Porcelain dish M 65	137	Tea pot	79-80, 82-84
Porcelain dish S 35	137	Tea strainer	85
Porcelain dish S 65	137	Thermal Box	213
Porcelain dish XS 35	136	Toast rack	90
Porcelain dish XS 65	136	Tongs	56, 149
Porcelain insert	73, 105, 138, 147, 161-162, 171, 174	Toothpick stand	119, 195
Porcelaine dish L 65	138	Top for alcoholic beverages	210, 219
Premium	52-53	Top for alcoholic beverages round	212, 221
Presenter buffet	180	Top for alcoholic beverages with glass holder	210
Presenter table	180	Top for cheese	210, 219
Profile	18-19	Top for cheese round	212, 221
Punch bowl ladle	58	Top for cooling with plexiglass hood	210, 219
R ack	70	Top for seafood	210, 219
Rack for utensils	148	Top for serving trolley	212, 221
Red wine holder	188	Top for sorbets	210, 219
Reserved sign	127	Transport unit	66
Roast beef trolley	209, 218	Tray stand high	170
Roll knife	60	Tray stand low	170
Room-Service-Trolley	213	Trend	54-55
Royal	30-31	U nderliner	104, 113
S alad tongs	56	V ase	124-125
Salt mill	116	Vegetable dish	101
Salt shaker	116-117	Vegetable spoon	57
Sauce boat	103	Vinegar / oil bottle	115
Sauce spoon	57	Vinegar and oil stand	115
Seafood trolley	207, 217	W all mount double	69
Serving dish	102	Wall mount single	69
Serving fork	56-57, 149	Water pitcher	190
Serving fork for Chafing Dish	56	Wine basket	189
Serving platter	104	Wine cooler	184-186
Serving spoon	56, 149	Wine trolley	204
Serving spoon for Chafing Dish	56	Wood dish „M“	110
Serving tray	91, 113, 166	Wood dish „S“	110
Serving tray „M“	109		
Serving tray „S“	109		
Serving trolley - basic model	205, 210, 219		

Article	Page	Article	Page
A ccent	44-45	Chariot pour service d'étage	213
Afternoon Tea étagère	96-97	Châssis de transport	66
Appareil à nettoyer l'argenterie HEPP	234	Chauffage électrique	77, 150, 164-165
Assiette de présentation	100	Chauffage électrique réglable	150, 164
Aura	28-29	Chillcup	114
B ac en porcelaine	138, 147, 161-162, 171	Chippendale	46-47
Bac en porcelaine pour support couverts à servir	148	Ciseaux à raisins	59
Bac réfrigérant GN 1/1	140	Cloche	176
Bac réfrigérant L	140	Cloche en verre plexi	169
Bac réfrigérant M	140	Cloche pour plateaux	171
Baguette	20-21	Cloche ronde	100-101
Beurrier	104-106	Coffee urn	75-77
Boîti à sucre	85	Contour	24-25
Bol en bois „M“	110	Coquetier	90
Bol en bois „S“	110	Corbeille à fruits	91
Bol en porcelain „M“	110	Corbeille à pain	90, 111-112
Bol en porcelain „S“	110	Corbeille à pain L	140
Bol en porcelain „S“ avec 3 divisions	109	Corbeille à pain S	140
Bol en porcelaine L 35	138	Coupe à fruits	175
Bol en porcelaine L 65	138	Coupe à glace	108
Bol en porcelaine M 35	137	Coupe-cigare	193
Bol en porcelaine M 65	137	Couteau à caviar	60
Bol en porcelaine S 35	137	Couteau à découper	57
Bol en porcelaine S 65	137	Couteau à fromage	58
Bol en porcelaine XS 35	136	Couteau à petit pain	60
Bol en porcelaine XS 65	136	Couteau à pizza/à steak	60
Bol rince-doigts	113	Couteau à steakhouse	58
Bol universel	74, 175	Couteau à tarte	58, 93
Box isotherme	213	Couteau de table	61
C adre GN 1/1 100	136	Couvercle	101-102
Cadre GN 1/1 40	136	Couvercle avec découpe	79
Cadre GN 1/1 70	136	Couvercle avec encoche	102
Cadre L 100	135	Couvercle pour Chafing Dish GN 1/1	159
Cadre L 40	135	Couvercle pour seau à champagne	184
Cadre L 70	135	Cruche en verre	73
Cadre M	140	Cuiller	179
Cadre M 100	135	Cuiller à café	61
Cadre M 70	135	Cuiller à caviar	60
Cadre S 100	134	Cuiller à dressing	57
Cadre S 40	134	Cuiller à légumes	57
Cadre S 70	134	Cuiller à party	58
Cadre XS 100	134	Cuiller à punch	58
Cadre XS 40	134	Cuiller à sauce	57
Cadre XS 70	134	Cuiller à servir	56, 149
Cafetière	79-83	Cuiller à servir pour Chafing Dish	56
Capot valvaire	158	Cuiller de table	61
Carafe à eau glacée	190-191	Cuiller-Fourch. univ.	58
Carlton	26-27	D iamond	42-43
Casse-noix	59	Dispenseur de céréales in-line	67-68
Chafing Dish	159	Dispenseur de céréales rotatif	67
Chafing Dish GN 1/1	151-154, 156-158	Dispenseur de jus	64
Chafing Dish Induction GN 2/3	143-144	Dispenseur de lait	65
Chafing Dish Induction rond	143	E cco	22-23
Chafing Dish Ø 24 cm	152	Element de refrigeration	170
Chafing Dish Ø 30 cm	151-153, 155	Elément supérieur à digestifs	210, 219
Chafing Dish Ø 40 cm	151, 153-156	Elément supérieur à digestifs avec porte-verres	210
Chandelier	120-123	Elément supérieur à digestifs, rond	212, 221
Chandelier pour banquet	121	Elément supérieur à fromage	210, 219
Chariot à Chafing Dish	208	Elément supérieur à fromage, rond	212, 221
Chariot à cigares	205, 215	Elément supérieur à rafraîchir avec cloche en verre plexi	210, 219
Chariot à digestifs	203, 214	Elément supérieur à sorbets	210, 219
Chariot à digestifs, rond	211, 220	Elément supérieur pour chariot à service	221
Chariot à fromage	207, 216	Elément supérieur pour chariot de service	212
Chariot à fromage, rond	211, 220	Elément supérieur pour fruits de mer	210, 219
Chariot à fruits de mer	207, 217	Emotion	48-49
Chariot à l'induction	208, 217	Étagère	175
Chariot à pâtisseries et desserts	206, 216	Exclusiv	50-51
Chariot à service - modèle de base	205, 210, 219	F ixation murale double	69
Chariot à service rond	221	Fixation murale simple	69
Chariot à service ronde	212	Fourchette	179
Chariot à sorbets	203, 215	Fourchette à découper	57
Chariot à viande	209, 218	Fourchette à gâteau	61
Chariot à vins	204		

Article	Page	Article	Page
Fourchette à homard	59	Porte-brûleur	150, 163
Fourchette à servir	56-57, 149	Porte-couteau à tarte	93
Fourchette à servir pour Chafing Dish	56	Porte-couverts	61
Fourchette à steakhouse	58	Porte-petits-fours	92-93
Fourchette de table	61	Portes bouteilles et verres	195
Fromagère	119	Pot à lait	79-84
G obelet en porcelaine	179	Pot à sorbet	108
Gobelet en verre	179	Pot avec couvercle	70
Goliath 2000 Type B	230-232	Pot isotherme	85
Goliath 2000 Type C	227-229	Poudre de nettoyage pour l'argenterie HEPPOLIT	233
I nsert en porcelaine	73, 105, 174	Pour verres à confiture	89
Insert en verre	73, 87-90, 114, 119, 174	Premium	52-53
K reuzband	34-35	Présentateur buffet	180
L égumier	101	Présentateur table	180
Lento	32-33	Presse-citron	85
Louche grande	57, 149	Produit de nettoyage pour l'argenterie	233
Louche petite	57	Profile	18-19
M armite potage	158	R afraîchisseur satinée à bouteilles	187
Marmite potage	158	Ramasse-miettes	59, 106
Medan	40-41	Récipient pour Chafing Dish	148, 157, 160, 162-163
Ménagère	70, 118	Récipient pour distributeur de céréales	68
Moulin à poivre	116	Rondelle	71
Moulin à sel	116	Royal	30-31
Moutardier	118	S alière	116-117
N uméro de table	126	Saucière	103
P anier à vin	189	Seau à champagne	184, 189
Partum	16-17	Seau à glace	191-192
Passoire à thé	85	Seau à vin	184-186
Pelle à glace	193	Service à sucre	87-88
Pelle à tarte	58	Service pour confitures et miel	89-90
Pellet de réfrigération	73	Soupière	102
Photophore	122-123	Sous-plat	104, 113
Pieds à palier M	141	Station potage	146, 157-159
Pieds à palier S	141	Style	38-39
Pince	56, 149	Sucrier	79-84
Pince à glace	193	Support	179
Pince à homard	59	Support à huîtres	113
Pince à pâtisserie	59	Support à snack	193-194
Pince à salade	56	Support à toast	90
Pince à spaghetti	56	Support couvert à servir	148
Pince à sucre	59	Support de bougie à chauffe-plat	124
Pince universelle	56	Support de buffet „L“	173, 195
Plaque de table avec réservé	127	Support de buffet „M“	173, 195
Plaque stands haut	170	Support de buffet „S“	173, 194
Plaque stands profond	170	Support pour 6 bouteilles	204
Plaques HEPP pour le nettoyage de l'argenterie	234	Support pour buffet GN 2/3	145-146
Plat à palier M chêne	141	Support pour buffet rond	144
Plat à palier M CORIAN®	141	Support pour jus de fruits	72
Plat à palier S chêne	141	Support pour seau à champagne	187
Plat à palier S CORIAN®	141	Support pour seau à vin	187-188
Plat à servir	102, 104	Support pour service universel	72, 174
Plat à tarte	93	Support pour table rond	145
Plat GN 1/4 chêne	139	Support pour verres à confiture	89
Plat GN 1/4 CORIAN®	139	Support universel	94, 107
Plat L chêne	139	T ableau à servir „M“	109
Plat L CORIAN®	139	Tableau à servir „S“	109
Plateau de service	91, 113, 166	Talia	36-37
Plateau d'exposition	166-168, 171	Théière	79-80, 82-84
Poivrier	116	Traverse	163
Poivrière	117	Trend	54-55
Polish argenté	233	Tube à glace	66
Port non-fumeur	127	V ase	124-125
Port numéro de table	127	Verre de rechange pour Vinaigrier-Huilier	115
Porte bouteilles et verres	195	Vinaigre / huile bouteille	115
Porte brûleur	78, 164	Vinaigrier-Huilier	115
Porte cure-dents	119, 195		
Porte pour numéro de table	126		
Porte-bouteilles	188		



Weitere Sortimente More Assortments

HEPP HOSPITALA – MIT INTELLIGENTER SYSTEMTECHNIK ZUR OPTIMALEN LÖSUNG

Als erfahrener Spezialist und Partner für Systemgeschirrtteile unterstützt Sie HEPP HOSPITALA von A–Z, von der ersten Beratung und Planung bis hin zur Optimierung Ihrer Prozessabläufe. Mehr als 40 Jahre Erfahrung machen uns zu einem der führenden Hersteller für Systemgeschirrtteile und Bestecke für die Gemeinschaftsverpflegung und zentrale Speisenverteilung in Krankenhäusern, Kliniken, Alten- und Pflegeheimen sowie Seniorenresidenzen.

Mehr Infos unter www.hepp.de

HEPP HOSPITALA – WITH SMART SYSTEM TECHNOLOGY FOR THE OPTIMUM SOLUTION

As experienced specialist and partner for system servingware utensils, HEPP HOSPITALA supports you every step of the way, from initial consulting and planning through to optimisation of your processes. 40-plus years of experience qualify us as one of the leading makers of system servingware utensils and cutlery for group food services and central food distribution in hospitals, clinics, nursing homes and care centres and senior-citizens' residences.

More infos online: www.hepp.de



AIRLINE INFLIGHT

Als Ausstatter namhafter Airlines ist HEPP überdies auf die Entwicklung und Herstellung von Equipment für die Bordverpflegung spezialisiert. Zugespitzt auf die Bedürfnisse der Bewirtung in Flugzeugen, unterstreichen hochwertige Qualitätsprodukte und innovative Lösungen die kulinarische Kompetenz an Bord.

Mehr Infos unter www.hepp.de

As outfitter to big-name airlines, HEPP is also specialised in the development and manufacture of equipment for in-flight service. Tailored to the needs of catering aboard aircraft, high-end quality products and innovative solutions underscore culinary competence in the air.

More infos online: www.hepp.de



HEPP
Professional Hotel Equipment
proHeq GmbH
Carl-Benz-Straße 10, D-75217 Birkenfeld (Germany)
Phone: +49 7231 4885 100
Fax: +49 7231 4885 190
www.hepp.de · info@hepp.de



Print  kompensiert
Id-Nr. 1652194
www.bvdm-online.de



79.0001.0000 - Printed in Germany 03-2016
Druckfehler und Irrtum für den gesamten Inhalt vorbehalten. The entire content is subject to misprints and errors.