

Ice The World Demands



Commercial Products

Suggested List Price Schedule

Effective January 1, 2015 - Updated April 15, 2015

The Suggested List Price Schedule is intended only as a guideline to pricing. It does not restrict the price a Distributor or Dealer may establish.

Our global-leading ice products and services are very local. To see how easy it is to bring them to your location, call 1-800-SCOTSMAN (726-8762) or visit www.scotsman-ice.com.

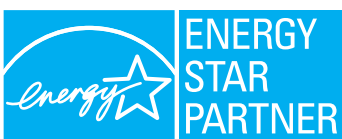



Why Scotsman?



Certified Product Performance

So you don't have to just take our word for it, AHRI provides Scotsman with certifications for almost every single one of our ice machines and bins. AHRI is the trusted source of performance certified heating, ventilation, air-conditioning and commercial refrigeration equipment and components.



Dedicated Global Sales & Service Network

Provides product availability and maintenance locally, when and where you need it. For technical assistance, call 1-800-533-6006.



No Need to Build Your Own BIM Ice Equipment Files.

Scotsman has done it for you. Our collection of Revit files can help you avoid costly mistakes and oversights. We have taken the guesswork out of specifying ice machines for your new build or renovation.



An Ice Form to Meet Every Need!

Diced Cube: Small & Medium

Ideal For: Mixed drinks, carbonated beverages, ice dispensing, ice retailing, banquet services & ice displays.

Advantages:

- Common recognizable form
- Small diced cube has favorable liquid displacement
- Choose the size that best suits customer's needs

The Original Chewable Ice® Scotsman Nugget Ice®

Ideal for: Carbonated beverages, blended cocktails, salad bars, produce displays & therapeutic uses.

Advantages:

- The Original Chewable Ice®!
- Versatile, cools drinks rapidly without foaming
- Helps drinks stay cool longer
- Health care facilities use in therapeutic and patient care
- Randomly sized bits of ice are actually flaked ice in compacted form
- Ice does not stick together - is free flowing at all times

Gourmet Cubes

Ideal For: Bar use, upscale restaurants, waitress stations & banquet services.

Advantages:

- Distinctively attractive and slow melting for use in mixed drinks and gourmet drinks
- Size and slow melting hardness make them ideal for banquet service when re-icing glasses of drinking water
- Non-stick characteristic makes scooping from a bin easy

Flake Ice

Ideal For: Produce, seafood, meat displays, blended cocktails, salad bars & therapeutic uses.

Advantages:

- Flakes cool more quickly than other forms of ice
- Cooling power is combined with very low production costs
- Molds to any shape for use in displays and salad bars
- Health care facilities use in therapeutic and patient care



Nugget



Small Diced



Medium Diced



Flake



Gourmet



Guidelines to Sizing Ice Systems:

Every operation is different and requires special considerations in sizing equipment. For new locations, use the guidelines below. You may want to add 10-20% for growth or add for unusual types of usage i.e. icing down drink barrels, bagging ice for resale. For a replacement unit, be sure to ask if the existing unit met the operator's needs. If not, add the amount of ice being purchased to the capacity of the existing unit to determine necessary production for the new unit.

Food Service

Restaurants:

1.7 lb (0.8 kg) per customer or 5.0 lb (2.3 kg) per seat.

Cocktail Lounge:

3 lb (1.4 kg) per customer.

Salad Bar:

Add 35 lb (15.9 kg) per cubic foot of display. Multiply by 2 or 3 depending on estimated refills required.

Fast Food:

0.9 lb (0.4 kg) per customer or 7.4 lb per seat. Use 2 oz. per 8-10 oz. drink; 4 oz. per 12-16 oz. drink.

Convenience Stores/Customer Self-Service

4 oz. per 12 oz. drink; 7 oz. per 20 oz. drink; 10 oz. per 32 oz. drink. Cold plate-add 50% more.

Health Care:

7 lb (3.2 kg) per patient bed. Use 2 lb (0.9 kg) per employee.



Lodging:

3 lb (1.4 kg) per guest room. Plan on substantially more if guests are allowed to fill ice chests.

Prodigy Plus® Modular Cubers Utilizing AquaArmor™ with AgION®

*Refer to page 18 & 20 for required bin tops.



Unit Dimensions (W x D x H)	Cube Size	Model Number	Condenser Type	24 hr Ice Production			Shipping Weight lb/kg	List Price Volts/Hz/Phase			
				70°F/21°C 50°F/10°C lb/kg	Air Water	90°F/32°C 70°F/21°C lb/kg		115/60/1 -1	208-230/60/1 -32	230/50/1 -6	
 22" x 24" x 23" 55.9 x 61.0 x 58.4 cm	Med. Sm.	C0322	Air	356/162		255/116	145/66	\$5,179 ☆	\$5,254 ☆	\$5,304 ●	
		C0322MA	Water	366/166		280/127	145/66	\$5,179			
		C0322SA	Air	356/162		255/116	145/66	\$5,179 ☆		\$5,304 ●	
		C0322SW	Water	366/166		280/127	145/66	\$5,179	\$5,254		
	Med. Sm.	C0522	Air	475/216		380/173	160/73	\$5,442	\$5,517	\$5,567 ●	
		C0522MA	Water	549/250		480/218	160/73	\$5,442			
		C0522SA	Air	475/216		380/173	160/73	\$5,442	\$5,517	\$5,567 ●	
		C0522SW	Water	549/250		480/218	160/73	\$5,442	\$5,517		
	 22" x 24" x 29" 55.9 x 61.0 x 73.7 cm	Med. Sm.	C0722	Air	790/358		590/268	180/82		\$6,673	
			C0722SA	Air	790/358		590/268	180/82		\$6,673	

Unit Dimensions (W x D x H)	Cube Size	Model Number	Condenser Type	24 hr Ice Production			Shipping Weight lb/kg	List Price Volts/Hz/Phase		
				70°F/21°C 50°F/10°C lb/kg	Air Water	90°F/32°C 70°F/21°C lb/kg		115/60/1 -1	208-230/60/1 -32	230/50/1 -6
 30" x 24" x 23" 76.2 x 61.0 x 58.4 cm	Med. Sm.	C0330	Air	350/159		300/136	160/73	\$4,992 ☆	\$5,067 ☆	
		C0330MA	Water	400/182		300/136	160/73	\$4,992		
		C0330SA	Air	350/159		300/136	160/73	\$4,992 ☆		
		C0330SW	Water	400/182		300/136	160/73	\$4,992		
	Med. Sm.	C0530	Air	525/238		380/172	175/80	\$5,516 ☆	\$5,591 ☆	\$5,641 ●
		C0530MA	Remote	500/227		400/181	175/80	\$5,416		
		C0530MR	Water	500/227		410/186	175/80	\$5,516		
		C0530MW	Air	525/238		380/172	175/80	\$5,516 ☆	\$5,591 ☆	\$5,641 ●
		C0530SA	Remote	500/227		400/181	175/80	\$5,416		
		C0530SR	Water	500/227		410/186	175/80	\$5,516		

Unit Dimensions (W x D x H)	Cube Size	Model Number	Condenser Type	24 hr Ice Production			Shipping Weight lb/kg	List Price Volts/Hz/Phase		
				70°F/21°C 50°F/10°C lb/kg	Air Water	90°F/32°C 70°F/21°C lb/kg		208-230/60/1 -32	208-230/60/3 N/A	230/50/1 -6
 30" x 24" x 23" 76.2 x 61.0 x 58.4 cm	Med. Sm.	C0630	Air	776/353		528/240	190/86	\$6,667		\$6,792 ●
		C0630MA	Remote	684/311		616/280	190/86	\$6,567		
		C0630MR	Water	722/328		650/295	190/86	\$6,667		
		C0630MW	Air	776/353		528/240	190/86	\$6,667		\$6,792 ●
		C0630SA	Remote	684/311		616/280	190/86	\$6,567		
		C0630SR	Water	722/328		650/295	190/86	\$6,667		
		C0630SW								

☆ = Energy Star qualified, Effective Feb. 1, 2013. ● = CE Approved.

Combine model number and electrical indicator when ordering for exact SKU, i.e. C0322MA-1. See page 16 for storage bins.

Prodigy Plus® Modular Cubers Utilizing AquaArmor™ with AgION®

Unit Dimensions (W x D x H)	Cube Size	Model Number	Condenser Type	24 hr Ice Production			Shipping Weight	List Price			
				70°F/21°C 50°F/10°C lb/kg	Air Water	90°F/32°C 70°F/21°C lb/kg		208-230/60/1 -32	208-230/60/3 -3	230/50/1 -6	
 30" x 24" x 29" 76.2 x 61.0 x 73.7 cm	Med.	C0830	Air Remote Remote Water	905/411 870/395 905/411 870/395 924/420	724/329 780/355 724/329 780/355 832/378	220/100 220/100 220/100 220/100 220/100	208-230/60/1 -32	208-230/60/3 -3	230/50/1 -6	\$8,645 ☆	\$8,870 ●
		C0830MA								\$8,545 ☆	\$8,870 ●
		C0830MR								\$8,645 ☆	
		C0830SA								\$8,545 ☆	
		C0830SR								\$8,645	
	Sm.	C1030	Air Remote Water Air Remote Water	1077/490 996/453 996/452 1077/490 996/453 996/452	844/384 851/387 851/386 844/384 851/387 851/386	235/107 235/107 235/107 235/107 235/107 235/107	208-230/60/1 -32	208-230/60/3 -3	230/50/1 -6	\$9,847 ☆	\$10,072 ●
		C1030MA								\$9,747 ☆	
		C1030MR								\$9,847	
		C1030MW								\$9,847 ☆	
		C1030SA								\$9,747 ☆	\$10,072 ●
		C1030SR								\$9,747 ☆	\$9,972 ●
		C1030SW								\$9,847	\$9,972 ●

Unit Dimensions (W x D x H)	Cube Size	Model Number	Condenser Type	24 hr Ice Production			Shipping Weight	List Price											
				70°F/21°C 50°F/10°C lb/kg	Air Water	90°F/32°C 70°F/21°C lb/kg		208-230/60/1 -32	208-230/60/3 -3	230/50/1 -6									
 48" x 24" x 29" 121.9 x 61.0 x 73.7 cm	Med.	C1448	Air Remote Water Air Remote Water	1553/706 1357/617 1444/656 1553/706 1357/617 1444/656	1242/565 1221/555 1300/591 1242/565 1221/555 1300/591	345/157 345/157 345/157 345/157 345/157 345/157	208-230/60/1 -32	208-230/60/3 -3	230/50/1 -6	\$10,948	\$11,173 ●								
		C1448MA								\$10,848 ☆									
		C1448MR								\$10,948	\$11,123								
		C1448MW								\$10,948	\$11,173 ●								
		C1448SA								\$10,848 ☆	\$11,023								
	Sm.	C1848	Air Remote Air Remote Water	1909/868 1828/831 1909/868 1828/831 1900/864	1527/694 1645/748 1527/694 1645/748 1710/777	355/161 355/161 355/161 355/161 355/161	208-230/60/1 -32	208-230/60/3 -3	230/50/1 -6	\$14,554	\$14,779 ●								
		C1848MA								\$14,454 ☆	\$14,679 ●								
		C1848MR								\$14,554	\$14,779 ●								
		C1848SA								\$14,454 ☆	\$14,679 ●								
		C1848SR								\$14,554	\$14,679 ●								
		C1848SW								\$14,554									
		Med.								C2148	Remote Remote	2248/1022 2248/1022	1849/840 1849/840	370/168 370/168	208-230/60/1 N/A	208-230/60/3 -3	230/50/1 N/A	\$17,718	\$17,943 ●
										C2148MR								\$17,718	\$17,943 ●
										C2148SR								\$17,818	

Unit Dimensions (W x D x H)	Cube Size	Model Number	Condenser Type	24 hr Ice Production			Shipping Weight	List Price			
				70°F/21°C 50°F/10°C lb/kg	Air Water	90°F/32°C 70°F/21°C lb/kg		208-230/60/1 N/A	208-230/60/3 -3	230/50/1 N/A	
 48" x 28.5" x 34" 121.9 x 72.39 x 86.36 cm	Med.	C2648	Remote Remote	2630/1193 2630/1193	2256/1023 2224/1009	430/195 430/195	208-230/60/1 N/A	208-230/60/3 -3	230/50/1 N/A	\$18,784 ☆	\$18,784
		C2648MR									
		C2648SR									

Modular Cuber Kits and Accessories

Unit Dimensions (W x D x H)	Model Number	Description	Shipping Weight lb/kg	List Price Volts/Hz/Phase		
				115/60/1 -1	208-230/60/1 -32	230/50/1 -6
22" x 24" x 23" 55.9 x 61.0 x 58.4 cm	Remote Condensers					
	ERC111	Remote condenser for C0522xR or C0530xR	95/43	\$1,728		
22" x 24" x 23" 55.9 x 61.0 x 58.4 cm	ERC311	Remote condenser for C0630xR, C0830xR, CC1030xR, or C1448xR	130/59		\$1,824	\$1,949
22" x 24" x 23" 55.9 x 61.0 x 58.4 cm	ERC611	Remote condenser for C1848xR or C2148xR	140/84		\$2,638	
22" x 24" x 29" 55.9 x 61.0 x 73.7 cm	PRC241	Remote condenser for C2648xR	135/61		\$3,070	

Model Number	Description	Shipping Weight lb/kg	List Price
Miscellaneous			
KERCF	Air filter for ERC111 or ERC311	5/2	\$119
RCKCME6GX	Remote condensing kit for connecting all Prodigy® models to non-Scotsman remote condenser coils	25/11	\$480
KTPS-5M	Tamper Proof Screw Kit (incl. Tool) to convert 22" (55.9 cm), 30" (76.2 cm) or 48" (121.9 cm) cuber	5/2	\$172
Line Sets			
RTE10	10 ft. (3m) precharged R-404A tubing	73/	\$326
RTE25	25 ft. (7.6m) precharged R-404A tubing	12/6	\$441
RTE40	40 ft. (12.2m) precharged R-404A tubing	17/8	\$527
RTE75	75 ft. (22.9m) precharged R-404A tubing	35/16	\$765
KTE4	Tube end kit - contains 4 quick connect fittings for any RTE Line Set	5/2	\$175
RTEL10	10 ft. (3m) precharged R-404A tubing. Use with C2648 remote cooled units	8/4	\$351
RTEL25	25 ft. (7.6m) precharged R-404A tubing. Use with C2648 remote cooled units	16/7	\$425
RTEL40	40 ft. (12.2m) precharged R-404A tubing. Use with C2648 remote cooled units	22/10	\$589
RTEL75	75 ft. (22.9m) precharged R-404A tubing. Use with C2648 remote cooled units	40/18	\$826
KTEL4	Tube end kit - contains 4 quick connect fittings for any RTEL Line Set	5/2	\$206
Prodigy® Modular Cuber Accessories			
KPAS	Kit - Prodigy Advanced Sustainability. Includes KSBU-N and KVS	10/4	\$968
KSBU	Kit - Prodigy Smart-Board™ - Use additional operational data for fast diagnosis	5/2	\$651
KSBU-N	Kit - Prodigy Smart-Board™ - Network connection	5/2	\$851
KVS	Kit - Prodigy Vari-Smart™ Ice Level Control - Adjust ice levels to match ice needs	5/2	\$292
Front Air Kit Flows			
KPMFA223-B	Kit - Prodigy® Front Air Flow, C0322 & C0522 (B revisions only)	11/5	\$204
KPMFA303-B	Kit - Prodigy® Front Air Flow, C0330, C0530 & C0630 (B and C revisions only)	13/6	\$244
KPMFA309-B	Kit - Prodigy® Front Air Flow, C0830 & C1030 (B revisions only)	15/7	\$307



CU0415



15" x 24" x 32"
38.1 x 61.0 x 96.5 cm
(Add 5.5" (14cm) Height for legs)

CU0715



15" x 24" x 32"
38.1 x 61.0 x 96.5 cm
(Add 5.5" (14cm) Height for legs)

CU0920



20" x 24" x 32"
50.8 x 61.0 x 96.5 cm
(Add 5.5" (14cm) Height for legs)



Cube Size	Model Number	Condenser Type	24 hr Ice Production			Storage Capacity lb/kg AHRI	Shipping Weight lb/kg	List Price Volts/Hz/Phase			
			70°F/21°C 50°F/10°C lb/kg	Air Water	90°F/32°C 70°F/21°C lb/kg			115/60/1 -1	208-230/60/1 -32	230/50/1 -6	
Med.	CU0415	Air	58/26		38/17	36/16	102/46	\$3,076		\$3,201 ●	
	— CU0415MA										
Med.	CU0715	Air	80/36		58/26	36/16	102/46	\$3,386		\$3,511 ●	
	— CU0715MA										
Med.	CU0920	Air	100/45		80/36	57/26	115/52	\$3,613		\$3,738 ●	
	— CU0920MA										
Optional Kits		Description									
	KUFM15	For ADA applications. Lowers CU0415 and CU0715 height to 31.9"						3/1			\$153
	KUFM20	For ADA applications. Lowers CU920 height to 31.9"						3/1			\$165



Prodigy® Self-Contained Undercounter Cubers



Unit Dimensions (W x D x H)	Cube Size	Model Number	Condenser Type	24 hr Ice Production			Storage Capacity lb/kg AHRI	Shipping Weight lb/kg	List Price Volts/Hz/Phase		
				70°F/21°C 50°F/10°C lb/kg	Air Water	90°F/32°C 70°F/21°C lb/kg			115/60/1 -1	208-230/60/1 -32	230/50/1 -6
 26" x 27 3/8" x 33" 66.0 x 69.5 x 83.8 cm (Add 6" (15.2cm) Height for legs)	Med. Sm.	CU1526	Air	150/68		110/150	80/36	150/68	\$4,251		
		— CU1526MA									
		— CU1526MW									
		— CU1526SA									
	Med. Sm.	CU1526SW	Water	175/80		124/156	80/36	150/68	\$4,251		
		— CU1526SA									
		— CU1526SW									
		— CU1526SW									
 30" x 30" x 33" 76.2 x 76.2 x 83.8 cm (Add 6" (15.2cm) Height for legs)	Med. Sm.	CU2026	Air	200/91		155/70	80/36	175/80	\$4,924	\$4,999	\$5,049 ●
		— CU2026MA									
		— CU2026SA									
	Med. Sm.	CU2026SW	Water	240/109		190/86	80/36	175/80	\$4,924	\$4,999	
		— CU2026SW									
		— CU2026SW									
 30" x 30" x 33" 76.2 x 76.2 x 83.8 cm (Add 6" (15.2cm) Height for legs)	Med. Sm.	CU3030	Air	250/114		217/98	110/50	200/91	\$5,724 ☆	\$5,799 ☆	\$5,849 ●
		— CU3030MA									
		— CU3030SA									
		— CU3030SW									
Optional Kits											
	KPUFM26 KPUFM30	Kit - Prodigy® Undercounter Floor Mount for CU1526 & CU2026. Kit - Prodigy® Undercounter Floor Mount for CU3030.						3/1 3/1			\$177 \$201

Self Contained Gourmet Cubers



Unit Dimensions (W x D x H)	Model Number	Condenser Type	24 hr Ice Production		Storage Capacity lb/kg AHRI	Shipping Weight lb/kg	List Price Volts/Hz/Phase			
			70°F/21°C 50°F/10°C lb/kg	Air Water lb/kg			90°F/32°C 70°F/21°C lb/kg	115/60/1 -1	208-230/60/1 N/A	230/50/1 N/A
 14 7/8" x 23 15/16" x 33 3/8" 37.78 x 60.80 x 84.77 cm	CU50	Air Air	65/30 65/30	50/23 50/23	26/12 26/12	100/45 105/48	\$3,702 \$4,392			
	CU50GA CU50PA*									
 15 3/16" x 23 5/8" x 28 7/8" 38.6 x 60 x 73.3 cm (Add 5.25"(13.3cm) Height for legs)	CU0515	Air	84/38	66/30	24/11	95/43	\$4,295 (Price includes legs)			
	CU0515GA									

Standard exterior finish: Stainless Steel.
 *CU50PA-1A comes with a pump drain instead of a gravity drain.

Prodigy Plus® Eclipse® Ice Machines



EH222SL	EH330SL	EH430SL
		
22" x 16.5" x 29" 55.9 x 41.9 x 71.1 cm	30" x 24" x 23" 76.2 x 61.0 x 58.4 cm	30" x 24" x 29" 76.2 x 61.0 x 71.1 cm

Cube Size	Model Number	Use With Condensing Unit	24 hr Ice Production		Shipping Weight lb/kg	List Price Volts/Hz/Phase	
			70°F/21°C 50°F/10°C lb/kg	Air Water lb/kg		90°F/32°C 70°F/21°C lb/kg	115/60/1 -1
Sm.	Ice Maker EH222SL	ECC0800 ECC1410	850/386 1030/468		215/98 225/102	\$5,122 ☆ \$5,122 ☆	\$5,322 ●
Sm.	Ice Maker EH330SL	ECC1200	1330/604		310/141	\$5,600	
Sm.	Ice Maker EH430SL	ECC1410 ECC1800	1425/648 1775/807		225/102 235/107	\$5,836 ☆ \$5,836 ☆	

ECC Features

- Energy efficient components save money on utility costs.
- Better corrosion resistance increases life of unit.
- One piece design makes installation and service easier.
- Maximizes air conditioning load.
- Allows for quiet operation in dining and working environments.
- Able to operate in wide outdoor temperature range from -20° F to 120° F.

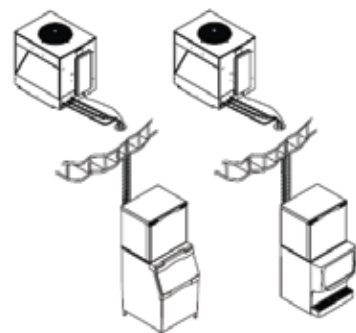

☆ = Energy Star qualified, Effective Feb. 1, 2013. ● = CE Approved.



+



=

Eclipse®
SYSTEM*

Approx. Ice Production (lb.)	Ice Maker Small Cube	Ice Maker List Price	Condensing Unit	Condensing List Price	System List Price
800	EH222SL	\$5,122	ECC0800	\$6,338	\$11,460 ☆
1000	EH222SL	\$5,122	ECC1410	\$7,600	\$12,722 ☆
1400	EH330SL	\$5,600	ECC1200	\$7,623	\$13,223
1400	EH430SL	\$5,836	ECC1410	\$7,600	\$13,436 ☆
1800	EH430SL	\$5,836	ECC1800	\$11,153	\$16,989 ☆

*Line sets and bin top kits must be purchased with Eclipse® System for proper operation of equipment.

Prodigy Plus® Eclipse® Condensing Unit



Unit Dimensions (W x D x H)	Model Number	Description	Shipping Weight lb/kg	List Price Volts/Hz/Phase		
				208-230/60/1 -32	208-230/60/3 -3	208-230/60/1 -6
 27" x 32.06" x 39.75" 68.58 x 81.4 x 100.9 cm	Remote Condensers					
	ECC0800	Remote condensing unit Eclipse 800 lb/364 kg systems	310/141	\$6,338		\$6,363
	ECC1200	Remote condensing unit Eclipse 1400 lb/636 kg systems	310/141	\$7,623		
	ECC1410	Remote condensing unit Eclipse 1000-1400 lb /455-636 kg systems	310/141	\$7,600	\$7,775	
	ECC1800	Remote condensing unit Eclipse 1800 lb/818 kg systems	310/141		\$11,153	
Miscellaneous						
KSLT075	Suction line trap for locating icemaker more than 20ft. (6.1m) below condenser unit.		1/1			\$143



Prodigy Plus® Eclipse® Accessories

Model Number	Description	Shipping Weight lb/kg	List Price
Line Sets			
3BRTE20-EH	Line set, 20ft. Refrigerant and Brazing required.	21/10	\$289
3BRTE35-EH	Line set, 35ft. Refrigerant and Brazing required.	32/15	\$409
3BRTE50-EH	Line set, 50ft. Refrigerant and Brazing required.	53/24	\$616
3BRTE75-EH	Line set, 75ft. Refrigerant and Brazing required.	79/36	\$921
KTE6-EH	Kit, Tube End, 6 Fittings, 3RTExx-EH Lineset	5/2	\$535

Prodigy Plus® Modular Flake Ice Machines

*Refer to page 18 & 20 for required bin tops.

Unit Dimensions (W x D x H)	Model Number	Condenser Type	24 hr Ice Production		Shipping Weight lb/kg	List Price Volts/Hz/Phase		
			70°F/21°C 50°F/10°C lb/kg	Air Water		90°F/32°C 70°F/21°C lb/kg	115/60/1 -1	208-230/60/1 -32
 22" x 24" x 23" 55.9 x 61.0 x 58.4 cm	F0522	Air Water	450/205 530/240	320/145 420/191	173/78 173/78	\$6,778 \$6,778		
	F0522A							
	F0522W							
 22" x 24" x 23" 55.9 x 61.0 x 58.4 cm	F0822	Air Remote Water	800/363 760/345 775/352	580/263 610/277 600/272	175/79 175/79 175/79	\$8,613 \$8,513 \$8,613		
	F0822A							
	F0822W							

Unit Dimensions (W x D x H)	Model Number	Condenser Type	24 hr Ice Production		Shipping Weight lb/kg	List Price Volts/Hz/Phase		
			70°F/21°C 50°F/10°C lb/kg	Air Water		90°F/32°C 70°F/21°C lb/kg	208-230/60/1 -32	208-230/60/3 -3
 22" x 24" x 27" 55.9 x 61.0 x 68.6 cm	F12222	Air Remote Water	1000/454 1250/567 1240/562	825/374 1050/476 1040/472	220/100 220/100 220/100	\$10,862 ☆ \$10,762 ☆ \$10,862	\$11,037 ☆ \$10,937 ☆	\$11,087 ●
	F1222A							
	F1222W							
 22" x 24" x 27" 55.9 x 61.0 x 68.6 cm	F1522	Air	1570/712	1100/499	224/102	\$14,236 ☆		
	F1522A							

Scotsman Nugget Ice®, The Original Chewable Ice®



Scotsman Ice Systems introduced the first Nugget ice machine in 1981 and today ice-chewing fanatics have embraced Nugget ice, which is soft and chewy. In fact, some of these chewers are looking for bags - not just cups - of Scotsman Nugget Ice®, creating a great opportunity for restaurants and convenience stores to add a new, high margin, repeat-business product customers really want. And Nugget ice makers from Scotsman can transform that opportunity into profit.

Beyond their crunch appeal, the slow-melting Nugget ice form cools drinks rapidly without foaming, and Nuggets displace more liquid than cube ice, lowering costs per cup. Nugget ice also consumes up to 50% less water and 15% less energy than cube machines. It all adds up to new customers, increased sales and a stronger bottom line.

☆ = Energy Star qualified, Effective Feb. 1, 2013. ● = CE Approved.

10. Combine model number and electrical indicator when ordering for exact SKU, i.e. C0322MA-1. See page 16 for storage bins.



Unit Dimensions (W x D x H)	Model Number	Condenser Type	24 hr Ice Production			Shipping Weight lb/kg	List Price Volts/Hz/Phase		
			70°F/21°C 50°F/10°C lb/kg	Air Water	90°F/32°C 70°F/21°C lb/kg		115/60/1 -1	208-230/60/1 N/A	230/50/1 N/A
 22" x 24" x 23" 55.9 x 61.0 x 58.4 cm	N0422	Air Water	420/191 455/206		310/141 350/159	172/78 172/78	\$7,036 \$7,036		
	N0422A N0422W								

Unit Dimensions (W x D x H)	Model Number	Condenser Type	24 hr Ice Production			Shipping Weight lb/kg	List Price Volts/Hz/Phase		
			70°F/21°C 50°F/10°C lb/kg	Air Water	90°F/32°C 70°F/21°C lb/kg		115/60/1 -1	208-230/60/1 -32	230/50/1 -6
 22" x 24" x 23" 55.9 x 61.0 x 58.4 cm	N0622	Air Remote Water	643/292 660/299 715/325		500/227 530/240 570/259	172/78 172/78 172/78	\$9,199 \$9,099 \$9,199		
	N0622A N0622R N0622W								
							\$9,274 ☆	\$9,324 ●	

Unit Dimensions (W x D x H)	Model Number	Condenser Type	24 hr Ice Production			Shipping Weight lb/kg	List Price Volts/Hz/Phase		
			70°F/21°C 50°F/10°C lb/kg	Air Water	90°F/32°C 70°F/21°C lb/kg		208-230/60/1 -32	208-230/60/3 -3	230/50/1 -6
 22" x 24" x 27" 55.9 x 61.0 x 68.6 cm	N0922	Air Remote Water	956/438 1044/474 1094/496		765/345 835/379 875/397	210/95 210/95 210/95	\$11,485 ☆ \$11,385 ☆ \$11,485		
	N0922A N0922R N0922W								
							\$11,710 ●		

Unit Dimensions (W x D x H)	Model Number	Condenser Type	24 hr Ice Production			Shipping Weight lb/kg	List Price Volts/Hz/Phase		
			70°F/21°C 50°F/10°C lb/kg	Air Water	90°F/32°C 70°F/21°C lb/kg		208-230/60/1 -32	208-230/60/3 -3	230/50/1 -6
 22" x 24" x 27" 55.9 x 61.0 x 68.6 cm	N1322	Air Remote Water	1180/535 1329/602 1354/614		950/431 1030/467 965/438	225/102 225/102 225/102	\$14,619 ☆ \$14,519 ☆ \$14,619		
	N1322A N1322R N1322W								
							\$14,794	\$14,844 ●	

☆ = Energy Star qualified, Effective Feb. 1, 2013. ● = CE Approved.

Combine model number and electrical indicator when ordering for exact SKU, i.e. C0322MA-1. See page 16 for storage bins.

Prodigy Plus® Remote Low Side Flake and Nugget Complete Packages

*Refer to page 18 & 20 for required bin tops.



OR



+



=

Remote Low Side Flake and Nugget Complete Packages

Approx. Ice Production (lb.)	Flaker Ice Machine	Ice Maker List Price	Nugget Ice Maker	Ice Maker List Price	Condensing Unit	Cond. Unit List Price	Flaker System Price	Nugget System Price
1000	F1222L	\$9,017	N0922L	\$9,552	NME954-RHS-A/C	\$6,305	\$15,322	\$15,857

Prodigy Plus® Remote Low Side Flake and Nugget Complete Packages

*Refer to page 18 & 20 for required bin tops.

Unit Dimensions (W x D x H)	Model Number	Ice Form	24 hr Ice Production		Shipping Weight lb/kg	List Price Volts/Hz/Phase		
			70°F/21°C 50°F/10°C lb/kg	Air Water 90°F/32°C 70°F/21°C lb/kg				
 22" x 24" x 27" 55.9 x 61.0 x 68.6 cm	Flaker		Flake Flake	1180/535	1000/454	217/98	115/60/1	208-230/60/1
	F1222L	F1522L		1445/655	1205/547	224/102	-1	N/A
	Nugget		Nugget Nugget	1090/494	915/415	217/98	\$9,017	
	N0922L	N1322L		1330/605	1100/499	224/102	\$11,500	\$9,552

Modular and Remote Low Side Flake and Nugget Ice Machines

Unit Dimensions (W x D x H)	Model Number	Condenser Type	24 hr Ice Production		Shipping Weight lb/kg	List Price Volts/Hz/Phase		
			70°F/21°C 50°F/10°C lb/kg	Air Water 90°F/32°C 70°F/21°C lb/kg				
 42" x 24" x 27" 106.7 x 61.0 x 68.6 cm	Flaker		Air Remote Low Side	2455/1116	1400/635	425/193	208-230/60/1	230/50/1
	FME2404AS	FME2404RLS		2365/1075	2000/909	255/115	-32	-6
	Nugget		Remote	2185/993	1825/829	425/193	\$20,556 ☆	\$20,956
	NME1854RS						\$17,277	\$21,665

Remote Condensing Units for Remote Low Side Flake and Nugget Ice Machines

Unit Dimensions (W x D x H)	Model Number	Refrigerant	Description	Shipping Weight lb/kg	List Price Volts/Hz/Phase
 29 1/2" x 28 5/8" x 38 1/2" 74.9 x 72.7 x 97.8 cm	Remote Condensing Units	R-404A	Condensing Unit for NME954RLS, FME1204RLS, N0922L, F1222L	220/87	\$6,305
NME954-RHS-A/C					

☆ = Energy Star qualified, Effective Feb. 1, 2013. ● = CE Approved.

Remote Low Side Flake and Nugget Accessories

Model Number	Description	Shipping Weight lb/kg	List Price
Line Sets			
N RTE45	45 ft. (13.7 m) non-precharged line set for remote low side flaker and nugget ice machines.	17/8	\$498

Flake & Nugget® Ice Machine Kits and Accessories

Unit Dimensions (W x D x H)	Model Number	Description	Shipping Weight lb/kg	List Price Volts/Hz/Phase		
				115/60/1 -1	208-230/60/1 -32	230/50/1 -6
	Remote Condensers					
29 1/2" x 29 1/8" x 38 15/32" 74.9 x 74.0 x 97.7 cm	ERC111	Remote condenser for F0822R or N0622R	95/43	\$1,728		
29 1/2" x 29 1/8" x 38 15/32" 74.9 x 74.0 x 97.7 cm	ERC311	Remote condenser for F1222R, N0922R or N1322R	130/59		\$1,824	\$1,949
28 1/2" x 39" x 34 5/8" 72.4 x 99.1 x 87.9 cm	PR2C240	Remote condenser for 2-F1222R, 2-N0922R, 1-FME2404R, 1-NME1854R	135/61		\$2,787	

Note: PR2C40-32A requires two line sets per ice machine when used with NME1854R; PRC2C240-32A requires two KPFHM kits when used with 2-F1222R or N0922R units.

Model Number	Description	Shipping Weight lb/kg	List Price
Line Sets			
RTE10	10 ft. (3.0 m) precharged R-404A tubing	7/3	\$326
RTE25	25 ft. (7.6 m) precharged R-404A tubing	12/5	\$441
RTE40	40 ft. (12.2 m) precharged R-404A tubing	17/7	\$527
RTE75	75 ft. (22.9 m) precharged R-404A tubing	35/15	\$765
KTE4	Tube end kit - Contains 4 quick connect fittings for any RTE Line Set	5/2	\$175
Miscellaneous			
KERCF	Air filter for ERC111 or ERC311	5/2	\$119
KFMCS	Cart switch adapter kit for F/N models	1/0.5	\$75
KPFHM	Headmaster Kit for use with ERC101, ERC151, ERC201, ERC302 or PR2C240	10/5	\$271
KCMR230	Fan relay kit used to operate remote condenser when two 230V units connected to one PR2C240	5/2	\$205
Prodigy Modular Flaker & Nugget Accessories			
KPAS	Kit-Prodigy Advanced Sustainability. Includes KSBU-N and KVS	10/4	\$968
KSBU	Kit-Prodigy Smart-Board™ - Use additional operational data for fast diagnosis	5/2	\$651
KSBU-N	Kit-Prodigy Smart-Board™ - Network connection	5/2	\$851
KVS	Kit-Prodigy Vari-Smart™ Ice Level Control - Adjust ice levels to match ice needs	5/2	\$292

Self-Contained Flake and Nugget Ice Machines

Unit Dimensions (W x D x H)	Model Number	Condenser Type	24 hr Ice Production		Storage Capacity lb/kg AHRI	Shipping Weight lb/kg	List Price Volts/Hz/Phase		
			70°F/21°C 50°F/10°C lb/kg	Air Water 90°F/32°C 70°F/21°C lb/kg			115/60/1 -1	208-230/60/3 N/A	230/50/1 -6
 24 1/4" x 24" x 33" 61.6 x 61.0 x 83.8 cm (add 6" (15.2 cm) Height for legs)	AFE424								
	AFE424A	Air	395/180	250/113	80/36	185/84	\$7,293		\$7,418
	AFE424W	Water	395/180	300/136	80/36	185/84	\$7,293		

Standard exterior finish: Grey rotocast polyethylene. (Price includes legs)

Meridian™ Icemaker / Dispensers



HID312



HID312A: 16.25" x 24.38" x 35"
HID312AW: 18.25" x 24.38" x 35"

HID525



HID525A: 21.25" x 24.38" x 35"
HID525AW: 23.25" x 24.38" x 35"
HID525W: 21.25" x 24.38" x 35"

HID540



HID540A: 21.25" x 24.38" x 41"
HID540AW: 23.25" x 24.38" x 41"
HID525W: 21.25" x 24.38" x 35"

Model Number	Condenser Type	24 hr Ice Production		Storage Capacity lb/kg	Shipping Weight lb/kg	List Price	
		70°F/21°C 50°F/10°C lb/kg	Air Water			90°F/32°C 70°F/21°C lb/kg	115/60/1 -1
HID312							
HID312A	Air	260/118		12/5	183/83	\$7,625	\$7,875
HID312AW*	Air	260/118		12/5	188/85	\$7,910	
HID525							
HID525A	Air	500/227		25/11	208/94	\$11,280	\$11,530
HID525AW*	Air	500/227		25/11	213/97	\$11,560	
HID525W	Water	500/227		25/11	208/94	\$11,280	
HID540							
HID540A	Air	500/227		40/18	215/98	\$12,250	
HID540AW*	Air	500/227		40/18	220/100	\$12,535	
HID540W	Water	500/227		40/18	215/98	\$12,250	

*Wall mount configuration.

Meridian™ Icemaker / Dispenser Kits and Accessories

HST16-A



HST16-A: 16.8" x 23.75" x 32"*
55.4 x 60.3 x 81.3 cm

HST16B-A



HST16-A: 16.8" x 23.75" x 32"*
55.4 x 60.3 x 81.3 cm

HST21-A



HST21-A: 21.8" x 23.75" x 32"*
42.7 x 60.3 x 81.3 cm

HST21B-A



HST21-A: 21.8" x 23.75" x 32"*
42.7 x 60.3 x 81.3 cm

Model Number	Description	Shipping Weight lb/kg	List Price
Dispenser Kits			
HST16-A	Stand with door, use with HID312, SS, includes 6" legs	50/23	\$1,150
HST16B-A	Stand for HID312, basic version, SS, includes 6" legs	50/23	\$1,075
HST21-A	Stand with door, use with HID525 & HID540, SS, includes 6" legs	80/36	\$1,199
HST21B-A	Stand for HID525 & HID540, basic version, SS, includes 6" legs	80/36	\$1,110
KLP24A	4" adjustable legs, plastic with metal foot (box of 4)	5/2	\$79

*Height includes 6" legs.

☆ = Energy Star qualified, Effective Feb. 1, 2013. ● = CE Approved.

iceValet® Hotel / Motel Cube Dispensers

HD22



22" x 33 1/2" x 47 1/4"
55.9 x 85.1 x 120.0 cm
(add 6" (15.2 cm) Height for legs)

HD30



30" x 33 1/2" x 47 1/4"
76.2 x 85.1 x 120.0 cm
(add 6" (15.2 cm) Height for legs)

Model Number	Actuation	Storage Capacity	Shipping Weight	List Price	
		lb/kg AHRI	lb/kg	115/60/1 -1	230/50/1 -6
HD22	Push	120/59	200/91	\$5,256	\$5,381* ●
HD22B					
HD30	Push Water Filler	180/81 180/81	220/100 225/102	\$6,143 \$6,757	\$6,268* ● * Price includes legs
HD30B HD30W					

Ice Only Counter Top Dispensers



Unit Dimensions (W x D x H)	Model Number	Actuation	Storage Capacity lb/kg AHRI	Shipping Weight lb/kg	List Price Volts/Hz/Phase 115/60/1 -1
 ID150: 22" x 30" x 35 5/8" 55.9 x 76.2 x 90.5 cm ID200: 30" x 30" x 35 5/8" 76.2 x 76.2 x 90.5 cm ID250: 30" x 30" x 39 5/8" 76.2 x 76.2 x 100.6 cm	Ice Only Dispensers				
	ID150B	Cup Activated	150/68	150/68	\$5,763
	ID200B	Cup Activated	200/91	195/89	\$6,902
	ID250B	Cup Activated	250/114	200/91	\$8,283

Ice Only Dispenser Kits and Accessories

Unit Dimensions (W x D x H)	Model Number	Description	Shipping Weight lb/kg	List Price
 IOBDMS22: 22" x 30" x 24" 55.9 x 76.2 x 61.0 cm IOBDMS30: 350" x 30" x 24" 76.2 x 76.2 x 61.0 cm (add 6" (15.2 cm) Height for legs)	Machine Stands	Machine stand for ID150 Machine stand for ID200 & ID250	93/42 120/55	\$1,622* \$1,628*
	IOBDMS22 IOBDMS30			
	Kits	Field installed water glass filler kit for ID150, ID200, & ID250 Field installed nugget ice kit for all ID dispensers	2/1 1/0.5	\$384 \$136
	KWGFID KNUGDIV			

* Price includes legs

Storage Bins

Model Number	Storage Capacity		Ext. Finish	Linear Material	Unit Dimensions (W x D x H)	Shipping Weight lb/kg	List Price	
	lb/kg	AHRI						
	Modular Bins							
	B230P	242/110	190/86	Poly	Poly	30" x 32" x 28" (76.2 x 81.28 x 71.1 cm)	90/41	\$1,465
	B322S	370/168	290/132	Metallic	Poly	22" x 34" x 44" (55.9 x 86.4 x 111.8 cm)	140/64	\$1,853
	B330P	344/156	270/123	Poly	Poly	30" x 34" x 31" (76.2 x 86.4 x 78.7 cm)	90/41	\$1,734
	B530P	536/244	420/191	Poly	Poly	30" x 34" x 44" (76.2 x 86.4 x 111.8 cm)	110/50	\$1,886
	B530S	536/244	420/191	Metallic	Poly	30" x 34" x 44" (76.2 x 86.4 x 111.8 cm)	150/68	\$2,042
	B842S	778/353	610/277	Metallic	Poly	42" x 34" x 44" (106.7 x 86.4 x 111.8 cm)	185/84	\$2,748
	B948S	893/406	700/319	Metallic	Poly	48" x 34" x 44" (121.9 x 86.4 x 111.8 cm) Add 6" (15.2 cm) height for legs	220/100	\$2,863
	BH Upright Modular Bins							
	BH1100BB-A	1100/499	860/393	SS w/GBB*	Poly	48" x 34" x 50" (121.9 x 86.4 x 127.0 cm)	280/127	\$6,221
	BH1100SS-A	1100/499	860/393	SS	Poly	48" x 34" x 50" (121.9 x 86.4 x 127.0 cm)	280/127	\$7,626
	BH1300BB-A	1400/635	1100/499	SS w/GBB*	Poly	60" x 34" x 50" (152.4 x 86.4 x 127.0 cm)	320/145	\$7,211
	BH1300SS-A	1400/635	1100/499	SS	Poly	60" x 34" x 50" (152.4 x 86.4 x 127.0 cm)	320/145	\$8,816
	BH1600BB-A	1755/796	1375/624	SS w/GBB*	Poly	60" x 34" x 62" (152.4 x 86.4 x 157.5 cm)	370/168	\$7,670
	BH1600SS-A	1755/796	1375/624	SS	Poly	60" x 34" x 62" (152.4 x 86.4 x 157.5 cm) Add 6" (15.2 cm) height for legs	370/168	\$9,265

* Stainless steel with galvanized back and bottom



Bins include adjustable bin top filler panels for use with most ice machines. (See machine bin sizing chart on back page for special configurations). No extra charge for special bin tops when ordered with new bin purchase, except for field installed kit KBT50 - KBT54 bin tops. See page 18 for purchase price for field installed bin tops.

☆ = Energy Star qualified, Effective Feb. 1, 2013. ● = CE Approved.

Ice Express System Built-to-Order Only

Unit Dimensions (W x D x H)	Model Number	Description	Storage Capacity	Ext. Finish	Linear Material	Shipping Weight lb/kg	List Price
 <p>ICS-1 30" x 36" x 65" 76.2 x 91.4 x 165 cm ICS-2- 60" x 36" x 71" 152.4 x 91.4 x 180.3 cm ICS-2-SL 60" x 36" x 91" 152.4 x 91.4 x 231 cm ICS-3 90" x 36" x 71" 228.6 x 91.4 x 180.3 cm ICS-3-SL 90" x 36" x 101" 228.6 x 91.4 x 256.5 cm</p>	Ice Express System						
	ICS-1	1 Bay*	500/227	SS	Poly	320/145	\$12,487
	ICS-2	2 Bay*	1200/544	SS	Poly	530/241	\$22,621
	ICS-3	3 Bay*	1800/817	SS	SS	950/432	\$35,091
	ICS-3-SL	3 Bay with extension*	2900/1315	SS	SS	1190/541	\$43,244
	Options						
ICS-PADDLE	Replacement paddle, white plastic	N/A	Poly	SS	11/5	\$357	
ICS-SHOVEL	Shovel, white plastic	N/A	Poly	SS	11/5	\$357	
* Includes 1 poly cart for each bay. NOTE: All ICS systems & accessories ship F.O.B. Denver.							

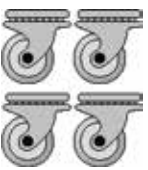
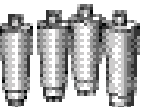
Bin Accessories

Unit Dimensions (W x D x H)	Model Number	Description	Shipping Weight lb/kg	List Price
	Caster Kits			
	KBC1	Bin caster kit for B530S, B842S, B948S, SB480, CU1526, CU2026, CU3030, BH bins and AFE [3.5" (8.9 cm) diameter wheels, 2 standard wheels and 2 locking. Raises bin 4 7/16" (11.3 cm)] - Not to be used with SB480 when using extension or B222S or B322S.	8/4	\$318
	KBC1P	Bin caster kit for B330P and B530P. [3.5" (8.9 cm) diameter wheels, 2 standard wheels and 2 locking. Raises bin a maximum of 4 7/16" (11.3 cm).	20/9	\$415
	Leg Kits			
	KLP7	Kit, legs, 6" black enamel, flanged feet, B Bins, HD Dispensers, AFE, CU0515, CU1526, CU2026 and CU3030.	5/2	\$157
	KLP8S	Kit, legs, 6" stainless steel, Bx22, Bx30, B842, B948 and BH bins, HD Dispensers CU1526, CU2026, CU3030 and AFE. Note: Legs are supplied with self-contained machines, bins and machine stands.	5/2	\$260
 <p>19 1/4" x 10 3/4" x 28 1/2" 48.9 x 27.3 x 72.4 cm</p>	Ice Bagger			
	BGS10	Hooks over any ice bin opening. Aluminum.	25/11	\$620
	KBAG	Case of 1000 8lb bags.	30/14	\$284
	KTAPE	One roll - 180 ft. (54.9 m)	1/0.5	\$38
	KSEALER	Tape sealer.	5/2	\$340
Note: BGS10 includes easy bagger, wicket of bags (250), tape sealer and 1 roll of tape.				
	Ice Scoop Holder			
	KHOLDER	Stainless steel scoop holder. Fits all B330, B530, B842 and B948 ice storage bins	2/1	\$95

Bin Top Kits

Model Number	Description	Shipping Dimensions L x W x H	Use On	Shipping Weight lb/kg	List Price
KBT14A	NME1854, FME2404	10 x 27 x 5	B948	8/4	\$291
KBT20A	NME454, FME504, NME654, FME804, NME954, FME1204	25 x 31 x 4	B230, B330, B530	25/11	\$476
KBT22A	All 30" (76.2 cm) modular cubers, flakers or nugget makers	17 x 29 x 5	B948	11/5	\$308
KBT27	All 22" (55.9 cm) modular cubers, flakers or nugget makers except EH222	10 x 27 x 5	B230, B330, B530	8/4	\$288
KBT29	All 30" (76.2 cm) modular cubers	14 x 27 x 7	B842	10/5	\$326
KBT38	All 22" (55.9 cm) modular cubers, flakers and nugget makers except EH222	6 x 30 x 17	B948	14/7	\$366
KBT38-2X	All 22" (55.9 cm) modular cubers, flakers and nugget makers except EH222 side by side	10 x 27 x 5	B948	5/2	\$203
KBT39	All 22" (55.9 cm) modular cubers, flakers and nugget makers except EH222	14 x 27 x 7	B842	10/5	\$326
KBTABS	EH222	26 x 24 x 7	ABS	24/11	\$1,201
KBT40A	EH222	26 x 24 x 7	ID150	24/11	\$1,148
KBT41	EH222	32 x 32 x 5	ID200, ID250	25/11	\$1,322
KBT42	All 22" modular ice machines except EH222	31 x 33 x 5	ID150	12/5	\$561
KBT43	All 22" modular cubers and nugget makers except EH222	33 x 47 x 5	ID200, ID250	26/12	\$746
KBT44	All 30" modular cubers	32 x 33 x 2	ID200, ID250	13/5	\$522

Field Installed - BH1100, BH1300, BH1600

Model Number	Description	Shipping Dimensions L x W x H	Use On	Shipping Weight lb/kg	List Price
KBT50	SS top for EH222	36 x 63 x 5	BH1100	80/36	\$1,728
KBT51	SS top for (2) EH222 side-by-side	36 x 63 x 5	BH1100	80/36	\$1,728
KBT52	SS top for EH222	36 x 63 x 5	BH1300, BH1600	80/36	\$1,893
KBT53	SS top for (2) EH222 side-by-side	36 x 63 x 5	BH1300, BH1600	80/36	\$1,893
KBT54	SS top for (2) 30" (76.2 cm) cubers side-by-side	36 x 63 x 5	BH1300, BH1600	80/36	\$1,893

Accessory Kits

Model Number	Description	Shipping Weight lb/kg	List Price
Prodigy Plus® Nugget Dispenser Accessory Kits			
KDIL-PN-150	Kit, Ice Level Control with KVS, Prodigy Nugget on Cornelius DF or ED150	2/1	\$788
KDIL-PN-200	Kit, Ice Level Control with KVS, Prodigy Nugget on Cornelius DF or ED200	5/2	\$864
KDIL-PN-250	Kit, Ice Level Control with KVS, Prodigy Nugget on Cornelius DF or ED250	5/2	\$965
KDIL-PN-ID3	Kit, Ice Level Control with KVS, Prodigy Nugget on Cornelius DF or ED300	2/1	\$156
KFSMF	Kit, manual fill nugget for Coca Cola Freestyle dispenser	3/1	\$258
KFSTM	Kit, top mounted nugget for Coca Cola Freestyle dispenser	3/1	\$258

★ = Energy Star qualified, Effective Feb. 1, 2013. ● = CE Approved.

AquaDefense® System - Sanitation Solution

Unit Dimensions (W x D x H)	Model Number	Description	Shipping Weight lb/kg	List Price
	AquaBullet® Anti Microbial Wand	6 pack of Antimicrobial wands to prevent slime and mold build up. Used for modular cube ice machines.	5/2	\$1,049
	ADS-AB6			
AP1-P 5 5/8" x 4 3/4" x 21 1/2" 14.3 x 12.1 x 54.6 cm AP2-P 16 1/2" x 5 1/2" x 19 1/4" 41.9 x 14.0 x 48.9 cm AP3-P 21" x 5 1/2" x 19 1/4" 53.3 x 14.0 x 48.9 cm	AquaPatrol™ Plus Water Filtration System	Single system - Cubers up to 650 lb (395 kg), flakers, nuggets and nugget dispensers up to 1,200 lb (544 kg) Twin System - Cubers over 650 lb (295 kg), flakers and nuggets over 1,200 lb (544 kg) Triple System - Cubers over 1,300 lb (590 kg) Replacement cartridge (package of 6) Replacement cartridge (package of 1)	7/3 11/5 16/7 7/3 3/1.5	\$338 \$620 \$967 \$542 \$106
	AP1-P			
	AP2-P			
	AP3-P			
	APRC6-P APRC1-P			

Water Filtration Systems By Everpure®

Unit Dimensions (W x D x H)	Model Number	Description	Shipping Weight lb/kg	List Price
SSM1 5 5/8" x 4 3/4" x 30 1/2" 14.3 x 12.1 x 77.5 cm SSM2 16 1/2" x 5 1/2" x 25 1/2" 41.9 x 14.0 x 64.8 cm SSM3 21" x 5 1/2" x 25 1/2" 53.3 x 14.0 x 64.8 cm	SSM Plus Filtration Systems with AquaArmor by AgION®	Single system - Cubers up to 650 lb (395 kg), flakers, nuggets and nugget dispensers up to 1,200 lb (544 kg) Twin System - Cubers over 650 lb (295 kg), flakers and nuggets over 1,200 lb (544 kg) Triple System - Cubers over 1,300 lb (590 kg)	7/3 11/5 16/7	\$473 \$818 \$1,303
	SSM1-P			
	SSM2-P			
	SSM3-P			
	SSMRC Replacement Cartridges	Single replacement cartridge (package of 1) 6 pack replacement cartridge (package of 6)	3/1.5 7/3	\$155 \$762
	SSMRC1 SSMRC6			
	SC Coarse Prefilters	10" (25.4 cm) Coarse prefilter 20" (50.8 cm) Coarse prefilter	5/2 11/5	\$163 \$232
	SC10-A SC20-A			
	SC Replacement Prefilters	SC10 replacement filter SC20 replacement filter	17/8 17/8	\$295 \$313
	SC10RC40 SC20RC20			



Better Filtration for Clear, Pure Ice.

Water Filtration Systems

Assisting in the ice machine sanitation battle, the Scotsman Ice Systems AquaDefense® sanitation system is a common-sense multimethod approach to defending your ice machine against undesirable microbes, bacteria, mold and algae. The AquaDefense® sanitation system features advanced defensive means.

AquaPatrol Plus offers better protection now in a smaller footprint, higher capacity and better filtration capability.



Machine/Bin Sizing Chart Dimensions in W x D x H - (Height includes 6" legs)

	BINS (Storage)	B322S	B230P	B330P	B530P/S	B842S	B948S	BH1100	BH1300	BH1600
ICE MAKERS (Production)	LBS	370	242	344	536	778	893	1100	1400	1755
C0322 C0522	300 500	22" x 34" x 73" 55.9 x 86.4 x 185.4 cm	30" x 31" x 57" 76.2 x 78.7 x 144.8 cm w/KBT27 top	30" x 34" x 59" 76.2 x 86.4 x 149.9 cm w/KBT27 top	30" x 34" x 73" 76.2 x 86.4 x 185.4 cm w/KBT27 top	42" x 34" x 73" 106.2 x 86.4 x 185.4 cm w/KBT39 top	48" x 34" x 73" 121.9 x 86.4 x 185.4 cm w/KBT38 top or KBT38-2x - side by side			
C0722	700	22" x 34" x 76" 55.9 x 86.4 x 193.0 cm	30" x 31" x 63" 76.2 x 78.7 x 160.0 cm w/KBT27 top	30" x 34" x 65" 76.2 x 86.4 x 165.1 cm w/KBT27 top	30" x 34" x 79" 76.2 x 86.4 x 200.7 cm w/KBT27 top	42" x 34" x 79" 106.2 x 86.4 x 200.7 cm w/KBT39 top	48" x 34" x 79" 121.9 x 86.4 x 200.7 cm w/KBT38 top or KBT38-2x - side by side	48" x 34" x 87" 121.9 x 86.4 x 221.0 cm	60" x 34" x 87" 152.4 x 86.4 x 221.0 cm	60" x 34" x 99" 152.4 x 86.4 x 251.5 cm
C0330 C0530 C0630	300 500 600		30" x 31" x 57" 76.2 x 78.7 x 144.8 cm	30" x 34" x 59" 76.2 x 86.4 x 149.9 cm	30" x 34" x 73" 76.2 x 86.4 x 185.4 cm	42" x 34" x 73" 106.7 x 86.4 x 185.4 cm w/KBT29 top	48" x 34" x 73" 121.9 x 86.4 x 185.4 cm w/KBT22A top			
C0830 C1030	800 1000				30" x 34" x 79" 76.2 x 86.4 x 200.7 cm	42" x 34" x 79" 106.2 x 86.4 x 200.7 cm w/KBT29 top	48" x 34" x 79" 121.9 x 86.4 x 200.7 cm w/KBT22A top	48" x 34" x 85" 121.9 x 86.4 x 215.9 cm	60" x 34" x 85" 152.4 x 86.4 x 215.9 cm No bin top or KBT54 - side by side	60" x 34" x 97" 152.4 x 86.4 x 246.4 cm No bin top or KBT54 - side by side
C1448 C1848 C2148	1400 1800 2000						48" x 34" x 79" 121.9 x 86.4 x 200.7 cm	48" x 34" x 85" 121.9 x 86.4 x 215.9 cm	60" x 34" x 85" 152.4 x 86.4 x 215.9 cm	60" x 34" x 97" 152.4 x 86.4 x 246.4 cm
C2648	2600						48" x 34" x 84" 121.9 x 86.4 x 213.4 cm	48" x 34" x 90" 121.9 x 86.4 x 228.6 cm	60" x 34" x 90" 152.4 x 86.4 x 228.6 cm	60" x 34" x 102" 152.4 x 86.4 x 259.1 cm
EH222	800 1000							48" x 34" x 85" 121.9 x 86.4 x 215.9 cm KBT50 - single unit KBT51 - side by side	60" x 34" x 85" 152.4 x 86.4 x 215.9 cm KBT52 - single unit KBT53 - side by side	60" x 34" x 85" 152.4 x 86.4 x 215.9 cm KBT52 - single unit KBT53 - side by side
EH330	1400					42" x 34" x 73" 106.2 x 86.4 x 185.4 cm w/KBT29 top	48" x 34" x 73" 121.9 x 86.4 x 185.4 cm w/KBT22A top	48" x 34" x 79" 121.9 x 86.4 x 200.7 cm	60" x 34" x 79" 152.4 x 86.4 x 200.8 cm KBT54 - side by side	60" x 34" x 91" 152.4 x 86.4 x 231.1 cm No bin top or KBT54 - side by side
EH430	1400 1800					42" x 34" x 79" 106.2 x 86.4 x 200.7 cm w/KBT29 top	48" x 34" x 79" 121.9 x 86.4 x 200.7 cm w/KBT22A top	48" x 34" x 85" 121.9 x 86.4 x 215.9 cm	60" x 34" x 85" 152.4 x 86.4 x 215.9 cm KBT54 - side by side	60" x 34" x 97" 152.4 x 86.4 x 246.4 cm No bin top or KBT54 - side by side
N0422 N0622	400 600	22" x 34" x 73" 55.9 x 86.4 x 184.4 cm	30" x 31" x 57" 76.2 x 78.7 x 144.8 cm w/KBT27 top	30" x 34" x 59" 76.2 x 86.4 x 149.9 cm w/KBT27 top	30" x 34" x 73" 76.2 x 86.4 x 185.4 cm w/KBT27 top	42" x 34" x 73" 106.2 x 86.4 x 185.4 cm w/KBT39 top	48" x 34" x 73" 121.9 x 86.4 x 185.4 cm w/KBT38 top or KBT38-2x - side by side			
N0922 N1322	900 1300	22" x 34" x 77" 55.9 x 86.4 x 195.6 cm		30" x 34" x 63" 76.2 x 86.4 x 160.0 cm w/KBT27 top	30" x 34" x 77" 76.2 x 86.4 x 195.6 cm w/KBT27 top	42" x 34" x 77" 106.2 x 86.4 x 195.6 cm w/KBT39 top	48" x 34" x 77" 121.9 x 86.4 x 195.6 cm w/KBT38 top or KBT38-2x - side by side	48" x 34" x 85" 121.9 x 86.4 x 215.9 cm	60" x 34" x 85" 152.4 x 86.4 x 215.9 cm	60" x 34" x 97" 152.4 x 86.4 x 246.4 cm
F0522 F0822	500 800	22" x 34" x 73" 55.9 x 86.4 x 184.4 cm	30" x 31" x 57" 76.2 x 78.7 x 144.8 cm w/KBT27 top	30" x 34" x 59" 76.2 x 86.4 x 149.9 cm w/KBT27 top	30" x 34" x 73" 76.2 x 86.4 x 185.4 cm w/KBT27 top	42" x 34" x 73" 106.2 x 86.4 x 185.4 cm w/KBT39 top	48" x 34" x 73" 121.9 x 86.4 x 185.4 cm w/KBT38 top or KBT38-2x - side by side	48" x 34" x 81" 121.9 x 86.4 x 205.7 cm	60" x 34" x 81" 152.4 x 86.4 x 205.7 cm	60" x 34" x 93" 152.4 x 86.4 x 236.2 cm
F1222 F1522	1200 1500	22" x 34" x 77" 55.9 x 86.4 x 195.6 cm		30" x 34" x 63" 76.2 x 86.4 x 160.0 cm w/KBT27 top	30" x 34" x 77" 76.2 x 86.4 x 195.6 cm w/KBT27 top	42" x 34" x 77" 106.2 x 86.4 x 195.6 cm w/KBT39 top	48" x 34" x 77" 121.9 x 86.4 x 195.6 cm w/KBT38 top or KBT38-2x - side by side	48" x 34" x 85" 121.9 x 86.4 x 215.9 cm	60" x 34" x 85" 152.4 x 86.4 x 215.9 cm	60" x 34" x 97" 152.4 x 86.4 x 246.4 cm
NME1854	1825					42" x 34" x 77" 106.2 x 86.4 x 195.6 cm	48" x 34" x 77" 121.9 x 86.4 x 195.6 cm w/KBT14A top	48" x 34" x 83" 121.9 x 86.4 x 210.8 cm	60" x 34" x 83" 152.4 x 86.4 x 210.8 cm	60" x 34" x 95" 152.4 x 86.4 x 241.3 cm
FME2404	2020					42" x 34" x 77" 106.2 x 86.4 x 195.6 cm	48" x 34" x 77" 121.9 x 86.4 x 195.6 cm w/KBT14A top	48" x 34" x 83" 121.9 x 86.4 x 210.8 cm	60" x 34" x 83" 152.4 x 86.4 x 210.8 cm	60" x 34" x 95" 152.4 x 86.4 x 241.3 cm

No bin top required when KBT not listed. + = Accepts multiple ice machines stacked side by side.

Ice Only Dispensers					Hotel D-Bins	
ABS	ID150	ID200	ID250	Cornelius ED300	HD22	HD30
150	150	200	250	300	120	180
	22" x 30 1/2" x 57 1/4" 55.9 x 77.5 x 145.4 cm w/KBT42 top	30" x 30 1/2" x 59" 76.2 x 77.5 x 149.9 cm w/KBT43 top	30" x 30 1/2" x 63" 76.2 x 77.5 x 160.0 cm w/KBT43 top		22" x 33 1/2" x 76 1/4" 55.9 x 85.1 x 193.7 cm w/KBT42 top	
	22" x 30 1/2" x 63 1/4" 55.9 x 77.5 x 160.7 cm w/KBT42 top	30" x 30 1/2" x 65" 76.2 x 77.5 x 165.1 cm w/KBT43 top	30" x 30 1/2" x 69" 76.2 x 77.5 x 175.3 cm w/KBT43 top		22" x 33 1/2" x 82 1/4" 55.9 x 85.1 x 208.9 cm	
		30" x 30 1/2" x 57 1/4" 76.2 x 77.5 x 145.4 cm w/KBT44 top	30" x 30 1/2" x 61 1/4" 76.2 x 77.5 x 155.6 cm w/KBT44 top	44" x 30 1/2" x 60" 112.7 x 77.5 x 152.4 cm w/Cornelius #629087943	30" x 33 1/2" x 76 1/4" 76.2 x 85.1 x 193.7 cm	
		30" x 30 1/2" x 63 1/4" 76.2 x 77.5 x 160.7cm w/KBT44 top	30" x 30 1/2" x 67 1/4" 76.2 x 77.5 x 170.8 cm w/KBT44 top	44 1/2" x 30 1/2" x 66" 112.7 x 77.5 x 170.8 cm w/Cornelius #629087943		
KBTABS	22" x 30 1/2" x 64 1/4" 55.9 x 77.5 x 163.2 cm w/KBT40A top	30" x 30 1/2" x 64 1/2" 76.2 x 77.5 x 163.2 cm w/KBT41 top	30" x 30 1/2" x 68 1/4" 76.2 x 77.5 x 173.4 cm w/KBT41 top	44 1/2" x 30 1/2" x 66" 112.7 x 77.5 x 167.6 cm w/KBT45 top		
		30" x 30 1/2" x 57 1/2" 76.2 x 77.5 x 145.4 cm w/KBT44 top	30" x 30 1/2" x 61 1/4" 76.2 x 77.5 x 145.4 cm w/KBT44 top	44 1/2" x 30 1/2" x 60 1/4" 112.7 x 77.5 x 153 cm w/Cornelius #629087943		
		30" x 30 1/2" x 63 1/4" 76.2 x 77.5 x 160.7cm w/KBT44 top	30" x 30 1/2" x 67 1/4" 76.2 x 77.5 x 170.8 cm w/KBT44 top	44 1/2" x 30 1/2" x 66 1/4" 112.7 x 77.5 x 167.6 cm w/Cornelius #629087943		
	22" x 30 1/2" x 57 1/4" 55.9 x 77.5 x 145.4 cm w/KBT42 top KVS, KNUGDIV	30" x 30 1/2" x 59" 76.2 x 77.5 x 149.9 cm w/KBT43 top KVS, KNUGDIV	30" x 30 1/2" x 63" 76.2 x 77.5 x 160.0 cm w/KBT43 top KVS, KNUGDIV	44 1/2" x 30 1/2" x 64" 112.7 x 77.5 x 152.4 cm KDIL-PN-ID3 w/Cornelius #629087966 and #629088644		
	22" x 30 1/2" x 61 1/4" 55.9 x 77.5 x 155.6 cm w/KBT42 top KVS, KNUGDIV	30" x 30 1/2" x 63" 76.2 x 77.5 x 160.0 cm w/KBT43 top KVS, KNUGDIV	30" x 30 1/2" x 67" 76.2 x 77.5 x 170.2 cm w/KBT43 top KVS, KNUGDIV	44 1/2" x 30 1/2" x 64" 112.7 x 77.5 x 152.4 cm KDIL-PN-ID3 w/Cornelius #629087966 and #629088644		

Ice Machine to Dispenser Kit Application Chart

Company	Dispenser	Ice Machines EH222	C0322/522/722	C0330/530/630/830 1030, EH330, EH430	N0422/622 922/1322
Cornelius	ED150	KBT40A	KBT42		KBT42 KDIL-PN-150
Cornelius	DF150	629087959*	02388*		02388* KDIL-PN-150
Cornelius	ED175	629087571*	629087907*		KDIL-PN-150 629087907*
Cornelius	ED200	KBT41	KBT43	KBT44	KBT43 KDIL-PN-200
	DF200	629087572*	08035*	08004*	
Cornelius	ED250	KBT41	KBT43	KBT44, KVS**	KBT43 KDIL-PN-250
	DF250	629087572	08035*	08004*, KVS**	
Cornelius	ED300	KBT45	08028*	629087943*	KDIL-N-ID3 629087966* 629088644*
	DF300	KBT45	08028*	629087943*	
Cornelius	Flavor Fusion 255	629088666*	KVS** 629088502*	KVS** 629088505*	KVS 629088681* 629097086*
	IDC215/ID255	629088662*	KVS** 629088537*	KVS** 629088536*	KVS 629088677* 629097086*
Lancer	22" Wide	82-4063*	82-4062*		
Lancer	30" Wide	82-4061*	82-4060*	82-4059*, KVS**	
SerVend	S-150/SV-150	SL27-020000246*	SL30-020000249* CL10-5012116*		KVS SL30-020000249 CL10-5012116*
SerVend	SV-175	SL22-020000198*	SL24-020000200*		KVS SL24-020000200*
SerVend	S-200/SV-200 S-250/SV-250	SL17-5031150*	SL25-5031609*	N3-5031125* CL10-5012116*	KVS SL25-5031609*

* Non Scotsman kits must be purchased from the dispenser manufacturer.

** Recommended but not required.

- Please check with dispenser manufacturer for appropriate kits. Application chart subject to change.
- Blank cells indicate can not be used together, N/A indicates no adapter needed.
- See spare parts price list for Scotsman A37693-021 & R629088514 pricing.
- Lancer dispensers must be specially configured for dispensing Scotsman Nugget Ice®
- Some Cornelius adapters kits include binstats - do not use the thermostats.
- All Cornelius ED/DF adapter kits have grey doors/covers. Contact Cornelius for black.
- All Cornelius FlavorFusion adapter kits are midnight black. Contact Cornelius for silver, orange or green.
- All Cornelius IDC255 adapter kits are black.

INTERNATIONAL PRODUCTS - Gourmet Modular Cubers



Unit Dimensions (W x D x H)	Cuber Size	Model Number	Condenser Type	24 hr Ice Production		Shipping Weight lb/kg	List Price Volts/Hz/Phase		
				70°F/21°C 50°F/10°C lb/kg	Air Water		90°F/32°C 70°F/21°C lb/kg	208-230/60/1 N/A	208-230/60/3 N/A
 MC16 MC16: 30" x 24" x 28" 77.2 x 60.8 x 71 cm MC46 MC46: 42" x 21" x 34" 107.9 x 53.9 x 87.4 cm	Med.	MC16 — MCMSHOTRA	Air	375/170		284/129	187/85		\$6,498 ●
	Med. Lg.	MC46 — MCM46AS — MCL46AS	Air Air	680/308 680/308		489/222 489/222	275/125 275/125		\$10,006 ● \$10,006 ●

INTERNATIONAL PRODUCTS - Gourmet Modular Cubers



ACM56 15" x 23" x 27" 38.6 x 60 x 69.3 cm (add 6" (15.2 cm) Height for legs)	ACM126 26" x 23" x 36" 68 x 60 x 93 cm (add 6" (15.2 cm) Height for legs)	ACM176 26" x 23" x 36" 68 x 60 x 93 cm (add 6" (15.2 cm) Height for legs)
--	---	---

Model Number	Condenser Type	24 hr Ice Production		Storage Capacity lb/kg AHRI	Shipping Weight lb/kg	List Price Volts/Hz/Phase			
		70°F/21°C 50°F/10°C lb/kg	Air Water			90°F/32°C 70°F/21°C lb/kg	115/60/1 -1	208-230/60/3 N/A	230/50/1 -6
ACM56 ACM56AS	Air	67/31		53/24	27/13	95/43			\$3,855* ●
ACM126 ACM126AS	Air	149/68		124/56	86/39	165/75	\$4,379		\$4,504* ●
ACM176 ACM176AS	Air	178/81		152/69	106/48	175/80	\$4,956		\$5,081* ●

Standard exterior finish: stainless steel * Price includes legs

INTERNATIONAL PRODUCTS - Storage Bins

Model Number	Storage Capacity lb/kg Application AHRI	Ext. Finish	Linear Material	Unit Dimensions (W x D x H)	Shipping Weight lb/kg	List Price



Please Note:

- Items are FOB Frimont, Italy
- **Not qualified for installation in North America**
- 2 year parts, 1 year labor warranty

Commercial Products

Effective January 1, 2015 - Updated April 15, 2015

The Suggested List Price Schedule is intended only as a guideline to pricing. It does not restrict the price a Distributor or Dealer may establish. Pricing and specifications subject to change without notice.



Warranty

Prodigy Plus[®], Eclipse[®] Cubers, iceValet[®] Hotel Dispensers & Bins

(EH, ERC, HD, BH, B, C0, C1, C2, CB, CU* & PR)

3 years parts

3 years labor

5 years parts & labor on Prodigy Evaporator, BH1100, BH1300, BH1600 & ICS systems

5 years parts on compressor and condenser

Prodigy Plus[®] and AutoSentry[™] Flake and Nugget Ice Machines

(FM, NM, F & N)

3 years parts

3 years labor

5 years parts on compressor

Other Flake Ice Machines

(AFE)

2 years parts

2 years labor

5 years on compressor

Other Cube Ice Machines

(CU50)

1 years parts

1 years labor

5 years parts on compressor

Essential Ice Cube Ice Machines

(CU0415, CU0715, CU0920)

3 years parts

3 years labor

Meridian[™] Ice & Water Dispensers

(HID)

3 years parts

3 years labor

5 years on compressor & condenser

Water Filtration Systems

(SSM & AP)

5 years on manifold parts only (SSMx-P & SCx0-A)

Ice Only Dispensers

(ID)

2 years parts

1 years labor

Remote Condensing Units

(RHS)

1 year parts

Terms & Conditions

- Production capabilities are typical peak production for 24 hours at 70°F/21°C air and 50°F/10°C water
- AHRI certified production capabilities are typical peak production for 24 hours at 90°F/32°C air and 70°F/21°C water
- (SS) Stainless Steel
- (RC) Rotocast Plastic
- (R-Air) Remote Air
- (RLS) Remote Lowside
- Freight F.O.B. Fairfax, South Carolina and Denver, Colorado, except international product F.O.B. Milan, Italy

Scotsman[®]
ICE THE WORLD DEMANDS

• 775 Corporate Woods Parkway, Vernon Hills, IL 60061 •

• 1-800-SCOTSMAN • Fax: 847-913-9844 • www.scotsman-ice.com • customer.relations@scotsman-ice.com •



Intertek

Intertek

