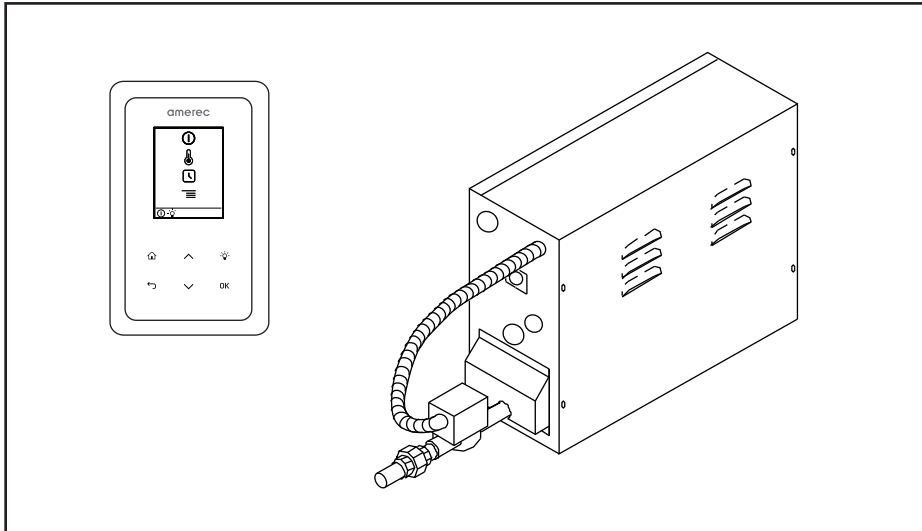


# amerec Steam Generator Installation and Service Instructions



## AT and 3T STEAMBATH GENERATORS For Models 4kW thru 14kW, 230-400V~ With T100 Control

**SAVE THESE INSTRUCTIONS**

**READ ALL INSTRUCTIONS CAREFULLY  
BEFORE INSTALLATION.**

**POST "WARNING" LABEL OUTSIDE  
STEAMBATH FOR SAFETY WARNINGS. POSTING IS  
REQUIRED ON DOOR OF STEAM ROOM OR ADJACENT  
TO DOOR FOR ALL COMMERCIAL INSTALLATIONS.**

### SECTION 1: GENERAL INFORMATION

The steam generators come CE marked, assembled and ready for installation. Check that the size and rating of the generator is suitable for your application; refer to Steam Room Construction and Generator Sizing Guide (document 4211-38).

#### IMPORTANT

An exhaust fan installed outside the steam room is strongly recommended to remove excess steam from the bathroom or shower area.



### WARNING

*Electrical grounding is required on all Steambath Generators.*

*All electrical supplies should be disconnected when servicing generator.*

*All wiring must be installed by a licensed electrical contractor in accordance with local and national codes.*

*All plumbing must be installed by a licensed plumber in accordance with all applicable local and national codes.*

*Generators are for indoor use only.*

*Generators are not for space heating purposes.*

*Be certain that steam bath enclosures are properly sealed to avoid water damage from escaping steam. It is recommended that 100% silicone caulk be used to seal all pipes and fittings. Steam must be prevented from escaping into the wall cavity.*

*Never shut off the water to a steam generator while it is in use.*

*Electric Shock Hazard - High voltage exists within this equipment. There are no user serviceable parts in this equipment.*

### WARNING

#### REDUCE THE RISK OF OVERHEATING AND SCALDING

1. Exit immediately if uncomfortable, dizzy or sleepy. Staying too long in a heated area is capable of causing overheating.
2. Supervise children at all times.
3. Check with a doctor before use if pregnant, diabetic, in poor health or under medical care.
4. Breathing heated air in conjunction with consumption of alcohol, drugs or medication is capable of causing unconsciousness.

**CAUTION!** Do not contact steam head. Stay at least 12" away from hot steam escaping from the steam outlet.

#### REDUCE THE RISK OF SLIPPING AND FALL INJURY

Use care when entering or exiting the steam room, floor may be slippery.

NOTE: For additional safety instructions, see owner's manual.



## Table of Contents

<b>SECTION</b>	<b>DESCRIPTION</b>	<b>PAGE</b>
1	Important Safety Instructions	3
2	Mounting Location	4
3	Mounting the Generator	4
4a	Plumbing Instructions	5 - 6
4b	Water Quality Requirements	6
5	Wiring Instructions	7-8
6	Electrical Information Chart	8
7	Operational Test	8
8	Service	9 - 10
9	Exploded Parts Diagram	12 - 13
10	Wiring Diagrams	14 - 16
11	Control Mounting Template	17 - 18

## IMPORTANT SAFETY INSTRUCTIONS

1. READ AND FOLLOW ALL INSTRUCTIONS.
2. WARNING - To reduce the risk of injury, do not permit children to use this product unless they are closely supervised at all times.
3. WARNING - To reduce the risk of injury:
  - a. The wet surfaces of steam enclosures may be slippery. Use care when entering or leaving.
  - b. The steam head is hot. Do not touch the steam head and avoid the steam near the steam head.
  - c. Prolonged use of the steam system can raise excessively the internal human body temperature and impair the body's ability to regulate its internal temperature (hyperthermia). Limit your use of steam to 10 - 15 minutes until you are certain of your body's reaction.
  - d. Excessive temperatures have a high potential for causing fetal damage during the early months of pregnancy. Pregnant or possibly pregnant women should consult a physician regarding correct exposure.
  - e. Obese persons and persons with a history of heart disease, low or high blood pressure, circulatory system problems, or diabetes should consult a physician before using a steambath.
  - f. Persons using medication should consult a physician before using a steambath since some medication may induce drowsiness while other medications may affect heart rate, blood pressure and circulation.
4. WARNING - Hyperthermia occurs when the internal temperature of the body reaches a level several degrees above the normal body temperature of 37 °C. The symptoms of hyperthermia include an increase in the internal temperature of the body, dizziness, lethargy, drowsiness and fainting. The effects of hyperthermia include:
  - a. Failure to perceive heat:
  - b. Failure to recognize the need to exit the steambath:
  - c. Unawareness of impending risk:
  - d. Fetal damage in pregnant women:
  - e. Physical inability to exit the steambath: and
  - f. Unconsciousness.

WARNING - The use of alcohol, drugs or medication can greatly increase the risk of hyperthermia.

**SAVE THESE INSTRUCTIONS**

**WARNING**

*Do not mount outdoors. Protect from freezing.*

*Unit must be located as to allow access for service.*

*The generator will not operate properly unless it is mounted level with the arrows pointed up.*

**SECTION 2: SELECT MOUNTING LOCATION**

SEE DIAGRAMS

The steam generator can be hung on a wall or sit on its base. The best mounting location will satisfy all or most of the following:

1. The steam line should slope to allow condensation to drain. Condensation should drain into the steam room.
2. The steam line should be less than 6 meters long; 3 m is preferred. Steam lines over 6 m long should be insulated.
3. The mounting location should minimize the number of bends and elbows in the steam line.
4. The generator should be installed in a dry, well ventilated area. Suggested locations are under a vanity, in a closet, attic, crawl space or basement. (*Not Subject to Freezing*)
5. The location should provide clearance for service and element removal. See diagram 1.
6. The mounting location should allow for a drain hook up.
7. The generator must be mounted in a minimum 0,2 m<sup>3</sup> space.
8. The generator must **NOT** be mounted in an area subject to freezing.

**SECTION 3: MOUNTING THE GENERATOR**

SEE DIAGRAMS

**Wall Mounting:**

1. Note the location of the mounting holes on the back of the generator. The screws must set directly into studs or equivalent supports. Drill two pilot holes on 305 mm centers and two holes on 254 mm centers (see diagram 2). Install two #10 1½" screws into the outer pair of holes.

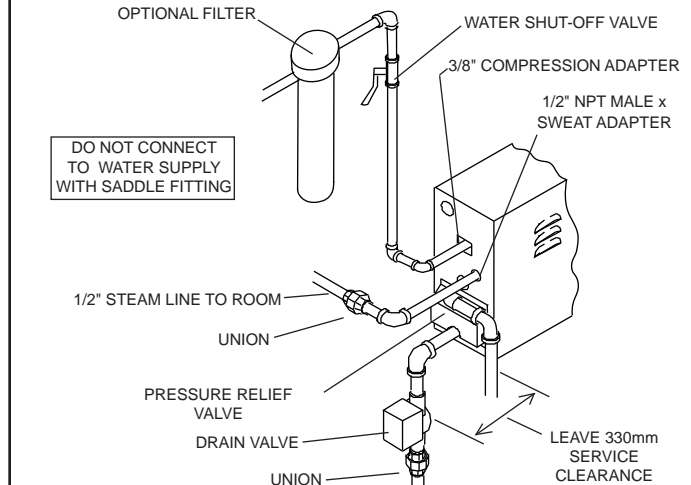
2. Carefully hang the generator on the two screws then tighten the screws. Install two #10 1½" screws into the inner pair of holes then tighten to secure the generator in place. Replace the front cover. Secure the front cover with six screws.

**Floor Mounting:**

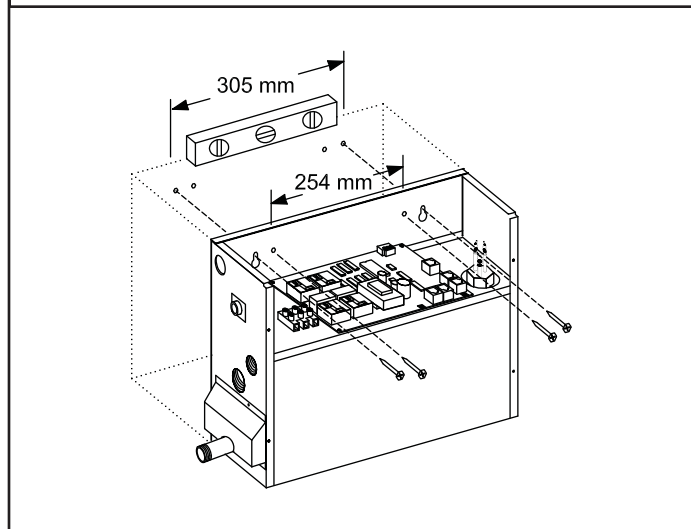
1. In general the width of the unit allows it to sit on a shelf, across the ceiling joists or on a floor. The generator must be restrained from moving. Normally the piping will provide adequate restraint. If not, additional restraint must be provided.

2. All floor installed generators must have provision for routine draining of the tank.

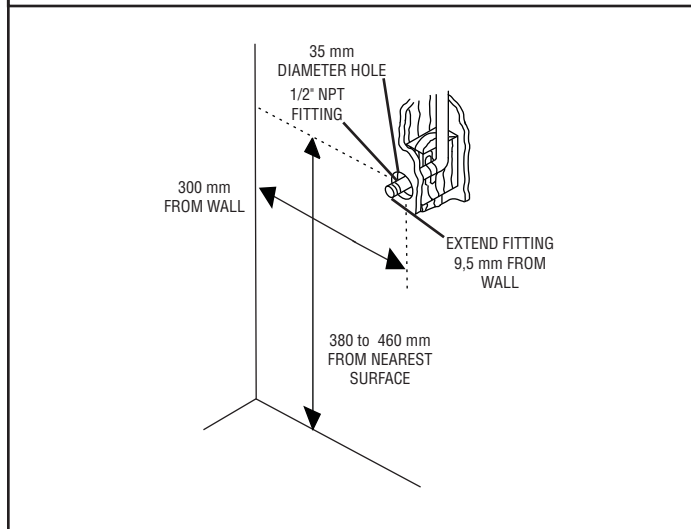
**DIAGRAM 1**



**DIAGRAM 2**



**DIAGRAM 3**



**SECTION 4a: PLUMBING INSTRUCTIONS**

SEE DIAGRAM

All plumbing shall be installed by a licensed plumber and conform with local and national codes.

**Materials (locally available):**

- 3/8" O.D. copper tube for the water supply to the generator.
- 3/8" water supply shut-off valve.
- 3/8" supply valve housing and filter (optional depending on local water conditions).
- 3/8" O.D. compression to 3/8" male NPT adapter.
- 1/2" copper unions. (2)
- 1/2" copper pipe for the tank drain.
- 1/2" copper pipe and 1/2" female NPT sweat adapter for the steam line between the generator and the steam room.
- 3/4" copper pipe, fittings, and a sweat union for the Pressure Relief Valve drain.
- Tube 100% silicone caulk.
- Rectorseal No. 5 pipe compound or equivalent.

**1. INSTALL WATER LINE**

**IMPORTANT**

Maximum recommended input water pressure not to exceed 5,5 Bar

Run 3/8" copper tube between the nearest cold water line and the WATER INLET fitting on the generator. Locate a shut-off valve near the generator. Connect this line to the generator with a 3/8" compression adapter. When tightening this fitting always use two wrenches so there will be no strain on the water inlet valve.

**IMPORTANT**

If the generator is mounted in a place difficult for the home owner to access, the water supply shut-off valve should be located where it can be quickly accessed in an emergency.

**IMPORTANT**

Do not use a saddle valve or saddle fitting for the water shut-off valve. Flush water supply line before final hookup.

**2. INSTALL STEAM LINE**

**Note: 12 KW and 14 KW Generators use 2 steam heads. See special instructions in Section 9 for these models before continuing.**

- A. At the generator:** Install a 1/2" male NPT sweat adapter directly into the tank. Install a 1/2" union in the steam line.
- B.** Run the 1/2" copper steam line from the generator to the steamroom. Refer to SECTION 2: SELECT MOUNTING LOCATION. For 12 and 14kW models, also refer to Section 9.
- C.** The steam line should enter the steam room 380 to 460 mm above the nearest surface and as far from bathers as possible. See diagram 3.
- D. At the steam room:** Drill/prepare a 35 mm hole for the each steam line entry. Center the 1/2" copper steam pipe in the 35 mm hole. See diagram 6.
  - Terminate the steam line with a 1/2" NPT male adapter. Stub the line out into the room 9,5 mm from the finished surface.
  - Secure the steam line to a structural member.

**IMPORTANT**

If the steam line is in an area where the temperature will be below 4°C or, if the line is more than 6 m long, best results can be obtained by insulating the steam pipe.

**WARNING**

**Do not connect the overpressure device output into the steam line.**

**Do not connect the drain valve into the steam line.**

**Do not put a shut off valve in the steam line. Avoid traps and valleys where water could collect and cause a steam blockage. The hot steam line must be insulated against user contact.**

**Centering the steam pipe is critical in rooms made of plastic, acrylic, resin, fiberglass or similar materials. Allowing the steam pipes to touch materials not rated for 100°C or higher will result in damage to these materials.**

**Do not install the steam head near bench(es) or where steam may spray or where condensation will drip on the user as this will present a scald hazard.**

**The steam pipe entry and any other entry into the steam room must be caulked to avoid damage caused by steam leakage into the wall.**

**The pressure relief valve must be installed in such a fashion that the risk of scalding is reduced to a minimum. Draining the pressure relief valve into the steam room may present a scald hazard.**

**Boiling water may be discharged from the drain. Proper precautions should be taken to insure safety.**

**Draining the tank into the steam room may present a scald hazard and/or damage materials used to construct the steam room.**

**SECTION 4a: PLUMBING INSTRUCTIONS**

(continued)

**3. INSTALL STEAM HEAD INSULATOR(S):** Fill in gaps (using 100% Silicone caulk between steam pipe and finished wall surface at point of entry (see diagram 6). Apply silicone caulk to the finished wall side of the steam head insulator and screw on hand tight until flush with the wall with the opening pointing down. If a hand tight fit does not align with the opening pointing down, use teflon tape on the steam line threads to adjust the fit. **(Note: 12 KW and 14 KW Generators use 2 steam heads - see Section 9)**

**4. INSTALL STEAM HEAD:**  
Slide the steam head on until it rests firmly against the finished wall. Tighten the hex head screw underneath the steam head to secure it in place with the Allen wrench provided. The steam head should be level with its fragrance reservoir at the top. See diagram 6.

**IMPORTANT**

Check all of the standard fixtures in the steam room. All fixture penetrations and steam head insulators must be sealed with 100% silicone caulk to avoid moisture damage within walls.

**5. INSTALL PRESSURE RELIEF VALVE**  
Install the pressure relief valve into its port on the generator. The pressure relief valve outlet must drain in accordance with local and national codes.

**6. INSTALL DRAIN VALVE**  
Install a 76 mm long 1/2" pipe nipple (provided) directly into the tank as shown in diagram 7. Install the drain valve (Refer to Amerec's ADT Installation Instructions, document 4211-113, for more detailed instructions). Install a 1/2" union on the outlet side of the drain valve. Run a 1/2" copper drain line to a gravity flow drain. Do not run the drain uphill. The drain must be connected in accordance with local and national codes.

**SECTION 4b: WATER REQUIREMENTS**

The nature of a steambath generator requires testing of the feedwater to avoid potentially high concentrations of impurities which can cause a deposit or scale to form on the internal surfaces. This deposit or scale can interfere with the equipment's proper operation and even cause premature failure. Concentration of impurities is generally controlled by treating the feedwater and/or "blowing down" the generator when it is not heating. The blow down process involves draining and rinsing the tank and refilling it with fresh water.

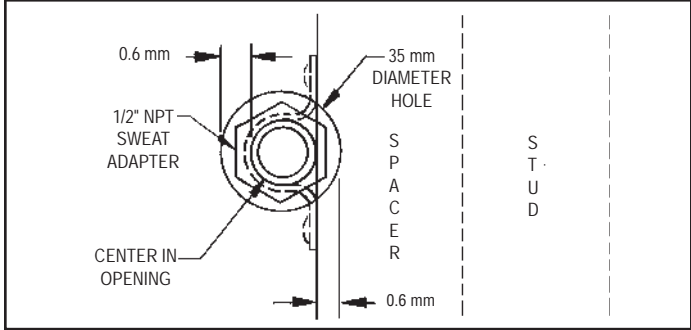
To ensure proper operation, the water supply should be tested prior to operating the equipment. There are several treatment processes which can be used if you have a water quality problem. A local reliable water treatment company can recommend the appropriate treatment if required. Recommended water quality is listed below:

**Feed Water Quality**

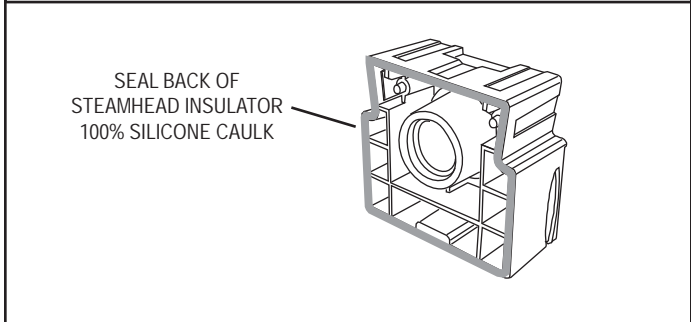
Hardness	10 - 30 ppm	(5.1 - 1.75 gpg)
T-Alkalinity	150 - 700 ppm	(8.75 - 40.8 gpg)
Silica Range	15 - 25 ppm	(1.28 - 1.45 gpg)
PH (strength of alkalinity)	10.5 - 11.5	

**IMPORTANT!** Regular maintenance will help your steamer work properly for a long time. Check for leaks, loose or damaged wires, signs of corrosion and calcium build up in the tank on the level probe. This is particularly important in areas with high calcium levels and other water quality problems. Calcium build can cause poor steamer performance and damage the heating elements!

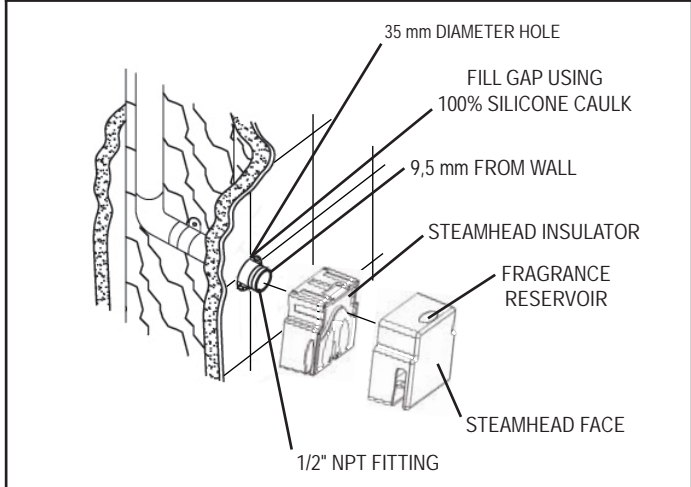
**DIAGRAM 4**



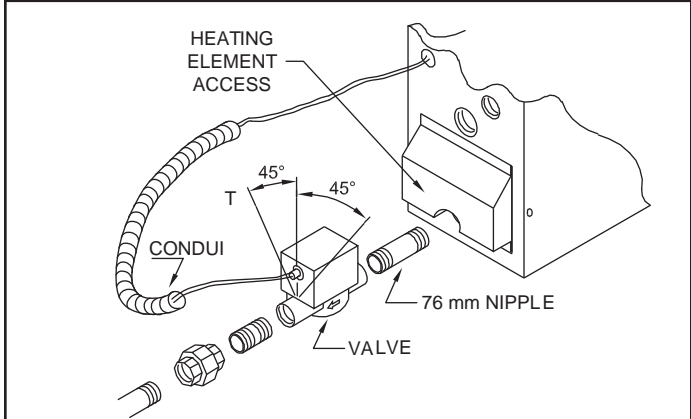
**DIAGRAM 5**



**DIAGRAM 6**



**DIAGRAM 7**





**IMPORTANT!** Regular maintenance will help your steamer work properly for a long time. Check for leaks, loose or damaged wires, signs of corrosion and calcium build up in the tank on the level probe. This is particularly important in areas with high calcium levels and other water quality problems. Calcium build can cause poor steamer performance and damage the heating elements!

**WARNING**

**Electrical Shock Hazard. Disconnect all electrical power before servicing the generator. All wiring should be installed by a licensed electrical contractor in accordance with local and national electrical codes.**

**The generator is designed for hookup with copper wire only.**

**SECTION 5: WIRING INSTRUCTIONS**

**1. T100 CONTROL CABLE ROUGH-IN** The low voltage controls can be mounted directly to a finished wall **up to 7.6 meters** from the generator and either inside or outside the steam room. A 7,6 m shielded 8 conductor cable (provided) is required for connecting the T100 control to the steam generator. String the 6,8 m cable from the control location through 13 mm holes in the wall studs or ceiling joists to the generator. **Note:** Do not staple through or damage cable. Use factory supplied cables only.

A mounting template is included at the end of this document. Using the supplied template, cut a hole in the finished wall where the control is to be mounted and pull the cable end out through the mounting hole.

**2. TEMPERATURE SENSOR CABLE ROUGH-IN** It is recommended that the sensor be mounted in the steam room 150 mm from the ceiling, but not directly over the steam dispersion head or more than 2,1 m above the floor. Using a 35 mm hole saw, drill a hole in the finished wall where the sensor is to be mounted. String the sensor cable from the sensor location through 13 mm holes in the wall studs or ceiling joists to the generator location. Leave 305 mm of slack at the sensor location. **Note:** Do not staple through or damage cable. Use factory supplied cables only.

**3. ELECTRICAL ROUGH-IN** Size wire for the generator as indicated by the Electrical Information Chart on page 8. Use correct size and type to meet electrical codes. Leave 4 feet of slack wire at generator location to finish hookup. Connect the generator to a dedicated circuit breaker. A GFI device is generally not required. One may be installed if required by local codes or the owner. A GFI device will tend to nuisance trip due to heater element aging.

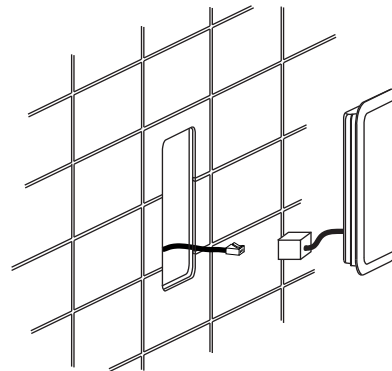
**4. ELECTRICAL FINISH** Route the copper supply wire with a 3/8" strain relief through the hole marked POWER ENTRY.  
 • Connect the supply wires to the power terminal block. See the wire diagrams on pages 14-16 for connections.  
 • Connect the ground to the ground lug (⊕).

**5. INSTALL T100 CONTROL** (The control cable should already be roughed-in to this location according to step 1, above.) Locate the control cable and plug it into the cable on the back of the control housing. See diagram 8. Run a bead of 100% silicone caulk around the perimeter on the back of the control housing, and insert the T100 into the finished wall, center the control and tape the control against the finished wall while the silicone hardens.

Route the generator end of the control cable through the generator hole marked CONTROL WIRING ENTRY using the strain relief provided. Plug the control cable into the T100 metal shielded connector on the printed circuit board assembly. See diagram 10.

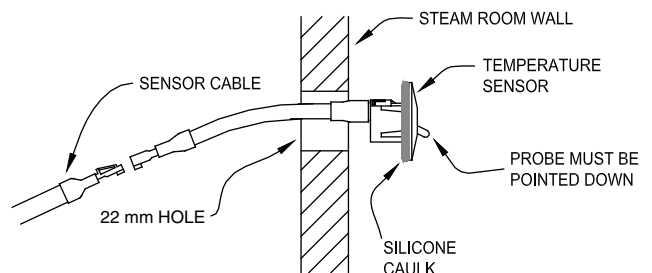
**DIAGRAM 8**

T100 CONTROL INSTALLATION

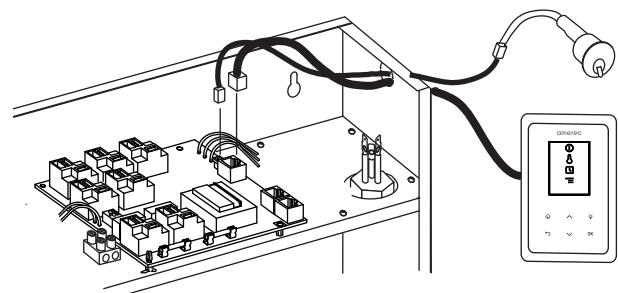


**DIAGRAM 9**

TEMPERATURE SENSOR INSTALLATION



**DIAGRAM 10**



**SECTION 5: WIRING INSTRUCTIONS (continued)**

**6. INSTALL TEMPERATURE SENSOR**

(The temperature sensor should already be roughed-in to this location according to step 2 in this section.). Locate the sensor cable, pull it out through the hole and plug it into the temperature sensor. It is best to tape the sensor and cable connection together to avoid disconnection inside the wall. Apply silicone caulk as shown in diagram 9 and insert the sensor in the hole. Make sure that the sensor probe is pointing down once installed. Tape the sensor in place while the silicone hardens. Route the generator end of the sensor cable through the generator hole marked CONTROL WIRING ENTRY using the control cable strain relief. Plug the sensor cable into the RM TEMP connector on the printed circuit board assembly. See diagram 10.

**SECTION 6 ELECTRICAL INFORMATION CHART**

ELECTRICAL INFORMATION CHART					
MODEL	AC VOLTAGE	PHASE	NOMINAL WATTS	NOMINAL AMPS	RECOMMENDED SAFETY DEVICE
AT5	230V~ N	1	5051	22,0	30A
AT7	230V~ N	1	6888	29,9	40A
AT10	230V~ N	1	9184	39,9	50A
<b>AT12</b>	230V~ N	1	11939	20,0 31,9	25A 40A
3T8	400V~ N	3	7806	11,3	15A
3T10	400V~ N	3	10102	14,6	20A
3T12	400V~ N	3	11939	17,2	25A
3T14	400V~ N	3	13766	19,9	25A

Notes: Use only copper wire rated 600V~ and 75°C or better

All models require Earth connection

All models require Mains plus Neutral connections

All Mains must supply minimum 195V~ while steamer is heating

Steamer must be connected to a means of disconnecting all Mains supply connections after installation

**AT12 steamers require two (2) Mains supplies**

**SECTION 7: OPERATIONAL TEST -- After Control Installation is Complete**

1. Assure power and water are on.
2. Press the control's ON/OFF switch. A light vibration should be felt and the control should light-up. (see control instructions included with control kit)
3. Allow 10 minutes for the steam to start.
4. Once the steam starts, press the ON/OFF switch. The steam should stop; there shouldn't be any water flow.
5. Press the ON/OFF switch.
6. Within one minute the unit should again produce steam. It should call for water once every two minutes or more depending on its power rating. It's normal for the flow of steam out the steam head to slow for up to 10 seconds each time the unit calls for water.
7. The unit will shut down automatically in 60 minutes. When the time runs out the steam will stop and there should not be any water flow.
8. If the unit does not operate as described above, refer to SECTION 9: TROUBLESHOOTING GUIDE.

**THE UNIT IS NOW READY FOR OPERATION.**



**SECTION 8: SERVICE**

SEE ELECTRICAL INFORMATION CHART

**1. DESCRIPTION OF STEAM GENERATOR**

The Printed Circuit Assembly (the "PCA") provides the basic functions necessary to produce steam. The PCA controls makeup water, provides a water level permissive for powering the elements and provides raw DC power for the system.

The PCA also provides regulated non-interruptible 12 VDC power for the generator control, 5 VDC for the temperature sensor. It also provides the interface circuitry between the control and the PCA. The control provides the room temperature control loop, power switching for "soft steam" and an adjustable steam bath timer.

**2. MAINTENANCE OF STEAM GENERATORS**

- **VISUAL INSPECTION** - Whenever the generator is opened, inspect for any evidence of water leaks. Inspect the wiring for any evidence of overheating. Check all electrical connections for tightness.

- **FLUSH TANK** - Flush monthly, or more often, depending on local water conditions.

- **FLUSHING PROCEDURE:**

1. The generator should be cool.
2. Press the ON/OFF button. The control should light.
3. Open the manual drain valve (if installed) and manually open the Autodrain valve by moving the lever until it latches.
4. The unit will drain without heating the water.
5. Allow the water to run for a full 10 minutes, then press the ON/OFF button. The control light should turn off.
6. Allow the unit to drain completely. When the water stops, close the drain valves.

**3. REPAIR OF GENERATORS**

**A. ELEMENT REPLACEMENT:** (refer to diagrams 11 & 12)

Disconnect power from the unit. Drain the tank. Remove the front and HEATING ELEMENT ACCESS covers. Note the wire connections. (See diagram) Remove the element wires. Using a hot water element socket, remove the element. To install a new element, mount a new element gasket on the element. Clean the element port and add a light coat of Rectorseal No. 5 pipe thread compound or equivalent to the threads. Insert and hand tighten the element-gasket combination. Notice the element end orientation as shown in diagram. Tighten the element until the orientation is the same as diagram,  $\pm 15^\circ$ . The gasket should be set and tight but not deformed to a rounded or bulbous appearance. If the drain valve was removed reinstall it. Reconnect the wiring. Test the unit per SECTION 7: OPERATIONAL TEST. Check for leaks at the element. Replace the front and HEATING ELEMENT ACCESS covers. **(Replace with factory supplied elements only)**

**B. PRINTED CIRCUIT REPLACEMENT:** (refer to diagrams 14 - 16)

Printed circuit assembly (PCA) removal and replacement must be performed in the following sequence: any other method can damage the PCA.

**IMPORTANT**

The PCA's contain static sensitive devices. Static electricity may damage PCA's. Handle accordingly.

Disconnect power from the unit. Note and tag the positions of all wires that plug into the printed circuit assembly mounted relays. Remove all the wires from the relays. When removing these wires, pull on the connector, not the wire. Note the blue wire connected to the shortest of the triple pronged water level probe. Disconnect all three wires from the water level probe. Remove PCA from all seven standoffs by pinching the tops. When it is completely disconnected, it may be lifted out of the enclosure. To install the board, reverse this procedure. The wire lugs must fit tightly onto the relay tabs! Test the unit per SECTION 7: OPERATIONAL TEST.

**IMPORTANT**

The blue wire connected to MAX on the PCA must be connected to the shortest of the three level probes, the black wire (MID) to the long probe with black tubing and the white wire (MIN) connected to the longest probe with white tubing.

**C. WATER SOLENOID REPLACEMENT:**

Disconnect power from the unit. Turn the water supply OFF. Disconnect the water supply from the water solenoid valve. Remove the front cover. Remove the two blue wires from the water solenoid valve. Rotate the self-tightening hose clamp so it can be loosened with a pair of pliers. Squeeze the clamp and move it down towards the shelf and off the valve outlet tube. Remove the two 1/4" - 20 hex head bolts and lock washers that attach the valve to the chassis. Pull the valve off the rubber fill hose. To install the valve, reverse these instructions. Test the unit per SECTION 7: OPERATIONAL TEST.

**D. LEVEL PROBE REPLACEMENT:** (refer to diagram 13)

Disconnect power from the unit. Remove the front cover. Note where the blue wire is connected to the triple pronged water level probe. Disconnect all three wires from the water level probe. Using a 1-1/4" (32 mm) box wrench, remove the level probe. Install a new level probe. Use Teflon Tape on threads of probe if required. Tighten until the bottom of the plastic nut is 6,4 to 9,5 mm above the top of the port. Reattach the three wires. Test the unit per SECTION 7: OPERATIONAL TEST.

**IMPORTANT**

The blue wire connected to "L" on the PCA must be connected to the shortest of the three level probes, the black wire to the probe with black tubing and the white wire to the probe with white tubing.

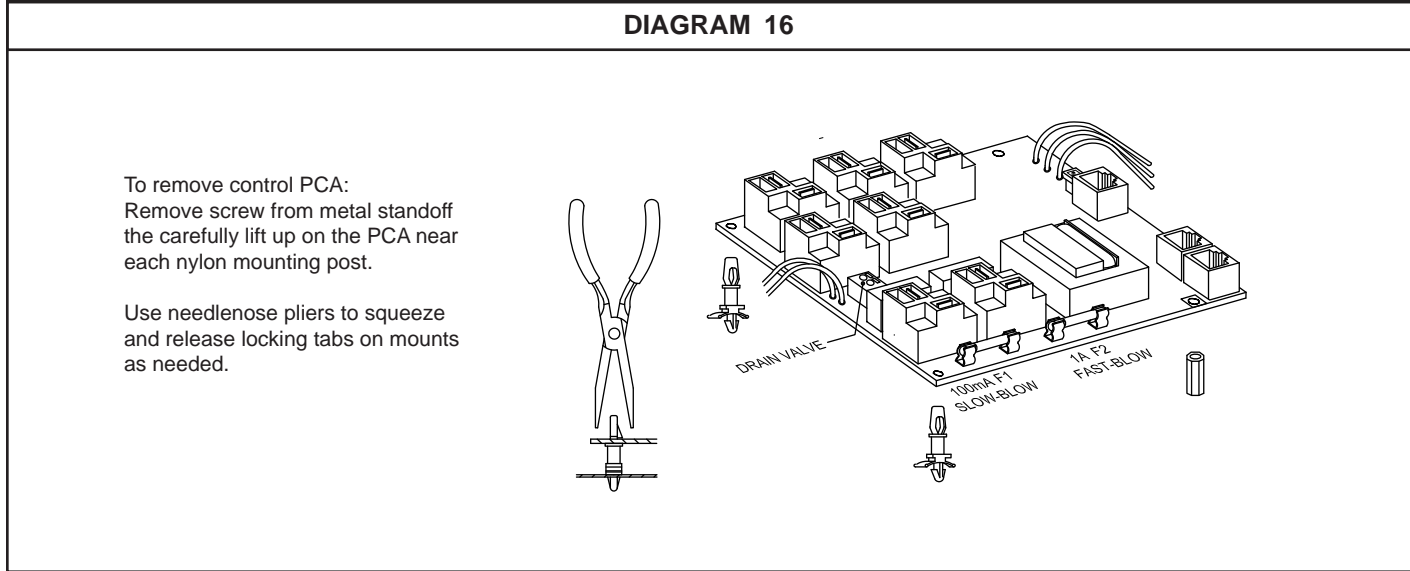
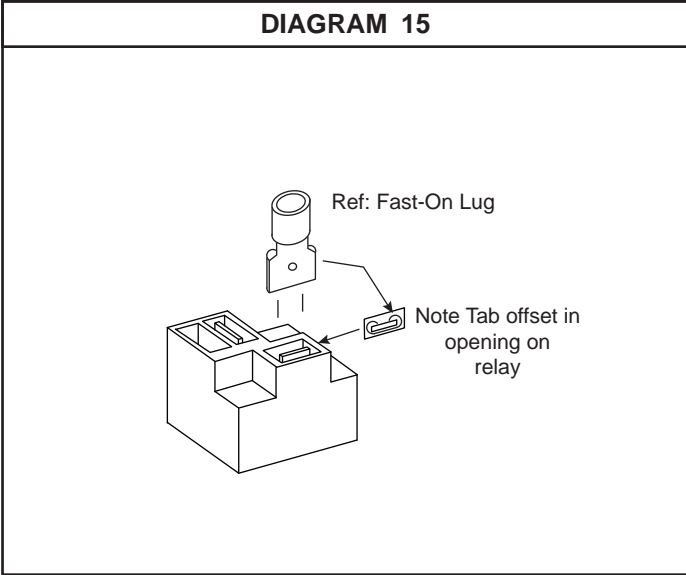
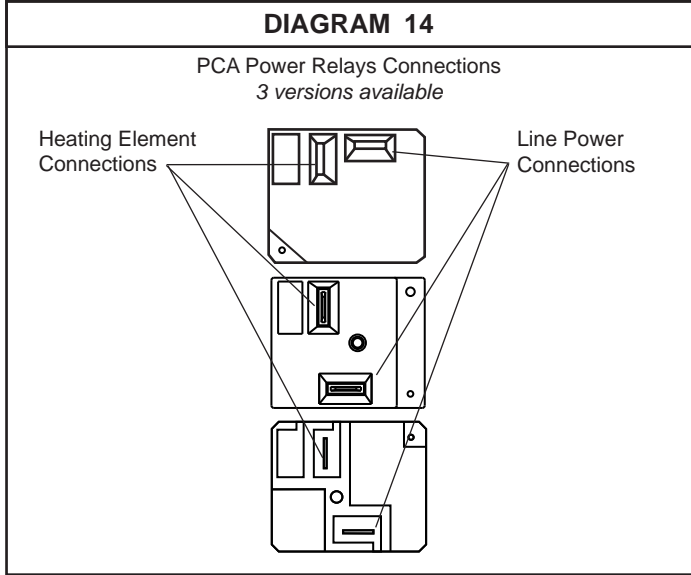
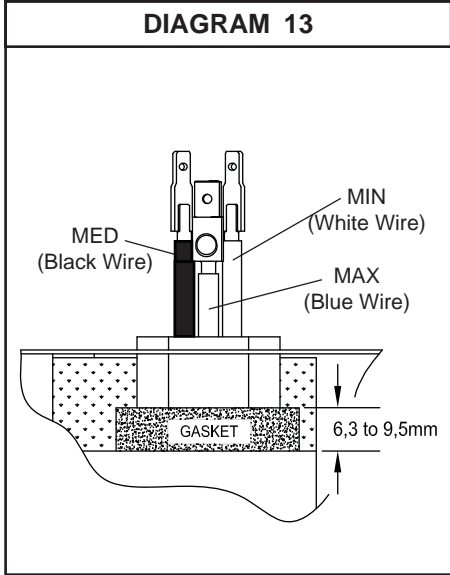
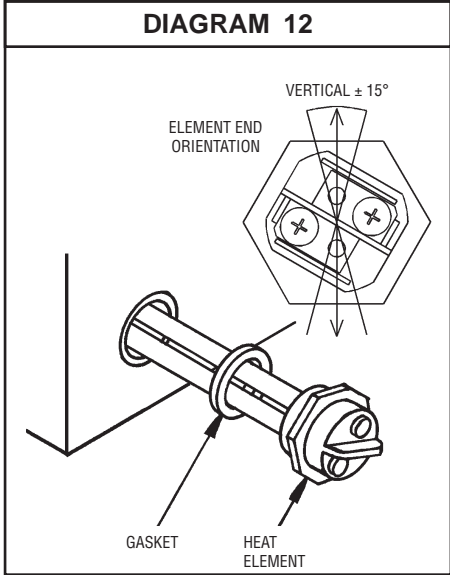
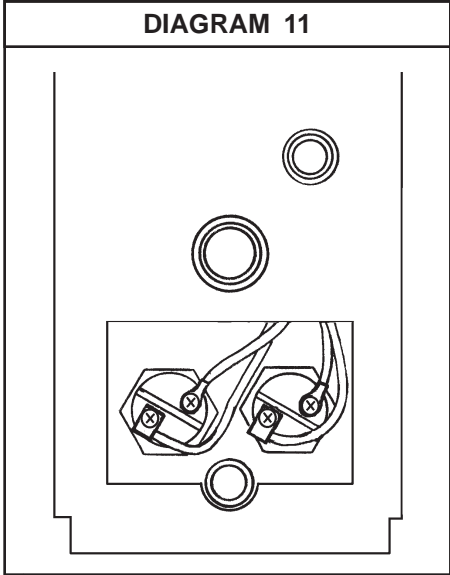
**IMPORTANT** The level probe may be extremely tight. Damage to the insulation or chassis may result unless the tank is properly blocked or supported during probe removal or installation. It may be necessary to completely disconnect and disassemble the generator.

**WARNING**

**Electrical shock hazard!**  
**Disconnect all electrical power**  
**before servicing the generator.**

**All wiring should be installed by**  
**a licensed electrical contractor in**  
**accordance with local**  
**and national codes.**

**For continued safe operation use**  
**factory authorized replacement**  
**parts only.**



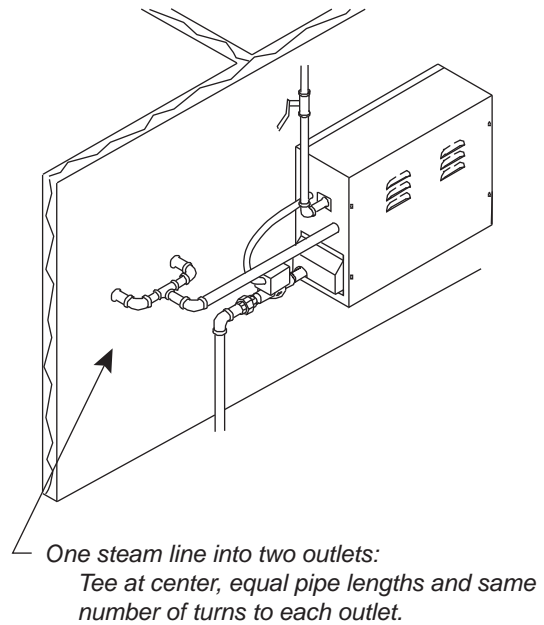
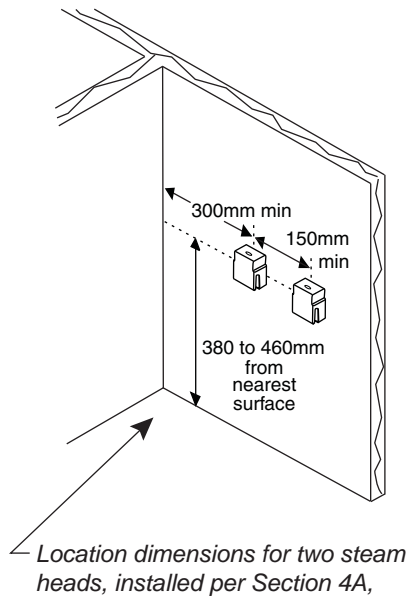
**SECTION 9: SPECIAL INSTRUCTIONS - 12 and 14kW STEAM OUTLETS**

For best performance, 12 and 14kW steamers should have two steam heads for each steam generator. Follow instructions in SECTION 4A PLUMBING INSTRUCTIONS for each steam outlet installation.

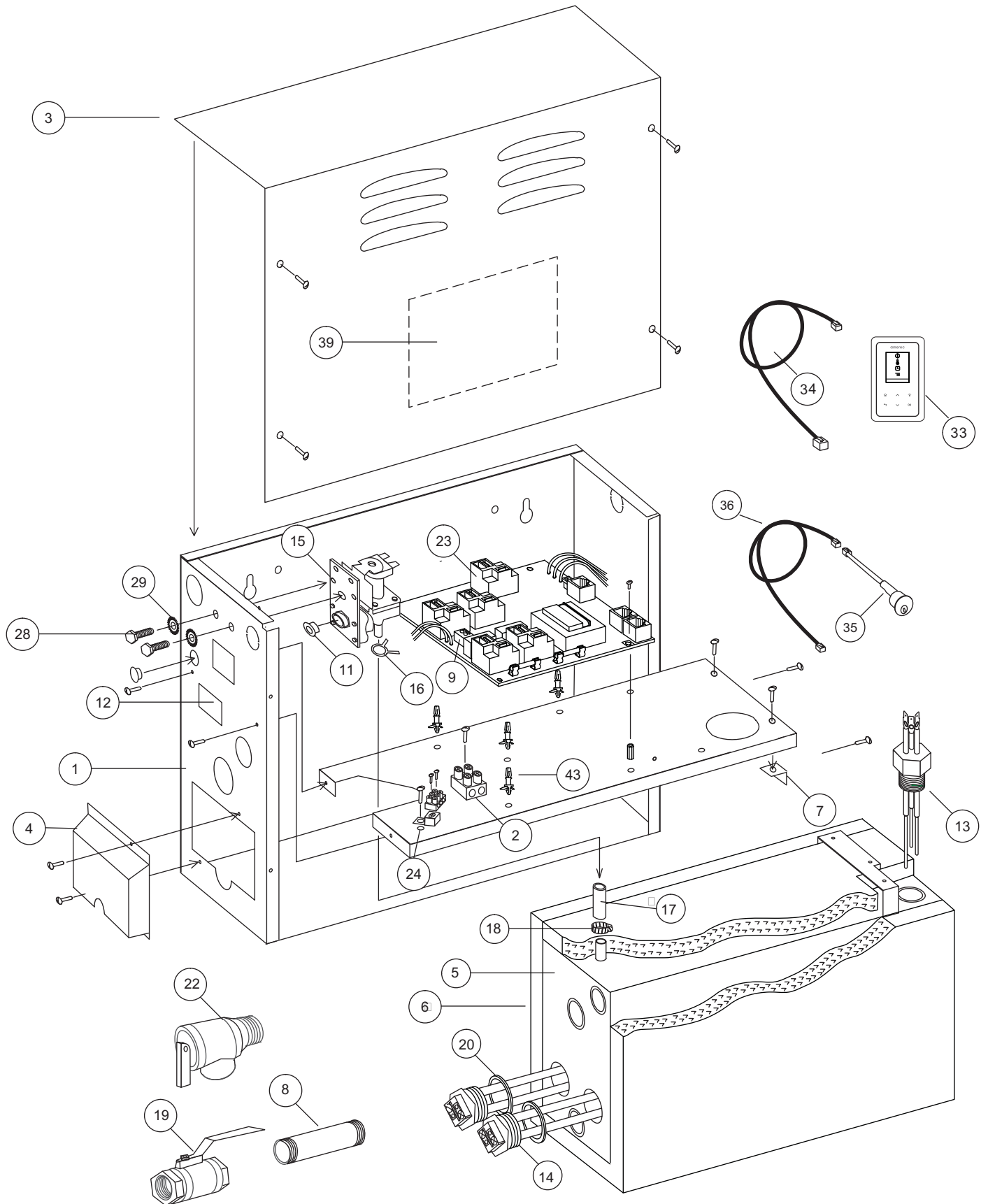
When installing two heads on one steam line:

Bring the steam line into a tee centered between the two heads then elbow both outlets through the wall (refer to Section 4A, starting at Step 2C).

Each head should have the same lengths of pipe and the same number of bends from the main steam line.



SECTION 10



NUMBER	PART NAME	DESCRIPTION
1	FRAME	CHASSIS
2	TERMINAL	POWER INPUT TERMINAL BLOCK
3	COVER	FRONT WITH WD LABEL
4	COVER	ELEMENT ACCESS
5	TANK	TWO ELEMENTS
6	INSULATION	BLANKET
7	BRACKET	L BRACKET
8	NIPPLE	DRAIN NIPPLE
9	TERMINAL	OPTIONAL AUTO FLUSH TERMINAL BLOCK
11	CAP	CAP, THREAD PROTECTOR
12	LABEL	ETL ID and RATING
13	PROBE	TRIPLE LEVEL
14	ELEMENT	REPLACEABLE ELEMENT
15	VALVE	WATER INLET
16	CLAMP	SELF-TIGHTENING
17	HOSE	WATER
18	CLAMP	AUGER
19	VALVE	MANUAL DRAIN
20	GASKET	ELEMENT
21	BRACKET	MOUNTING BRACKET
22	VALVE	PRESSURE RELIEF
23	PCA	PRINTED CIRCUIT ASSEMBLY, AT
24	LUG	GROUND
28	BOLT	1/4-20 x 1/2"
29	WASHER	1/4" LOCK
33	CONTROL	T100 CONTROL
34	CABLE	8 CONDUCTOR SHIELDED CABLE (FOR T100)
35	SENSOR	TEMPERATURE SENSOR
36	CABLE	2 CONDUCTOR CABLE (FOR TEMPERATURE SENSOR)
29	WASHER	1/4" LOCK
37	STEAM HEAD	DISPERSION HEAD (NOT SHOWN)
38	PLACARD	SAFETY (NOT SHOWN)
39	LABEL	WIRE DIAGRAM
40	FUSES	100mA SLO-BLO (NOT SHOWN)
41	FUSES	1A FAST-BLO (NOT SHOWN)
43	STANDOFF	STAND OFF

**PARTS AND/OR RETURNS:**

- For assistance or parts ordering, please contact your local Dealer or Amerec Technical Support.

Please help us to serve you better by:

1. Identifying the problem by using the troubleshooting guide in this manual.
2. Read Number 12, the ID/Ratings Label, to obtain your unit's model and code number.

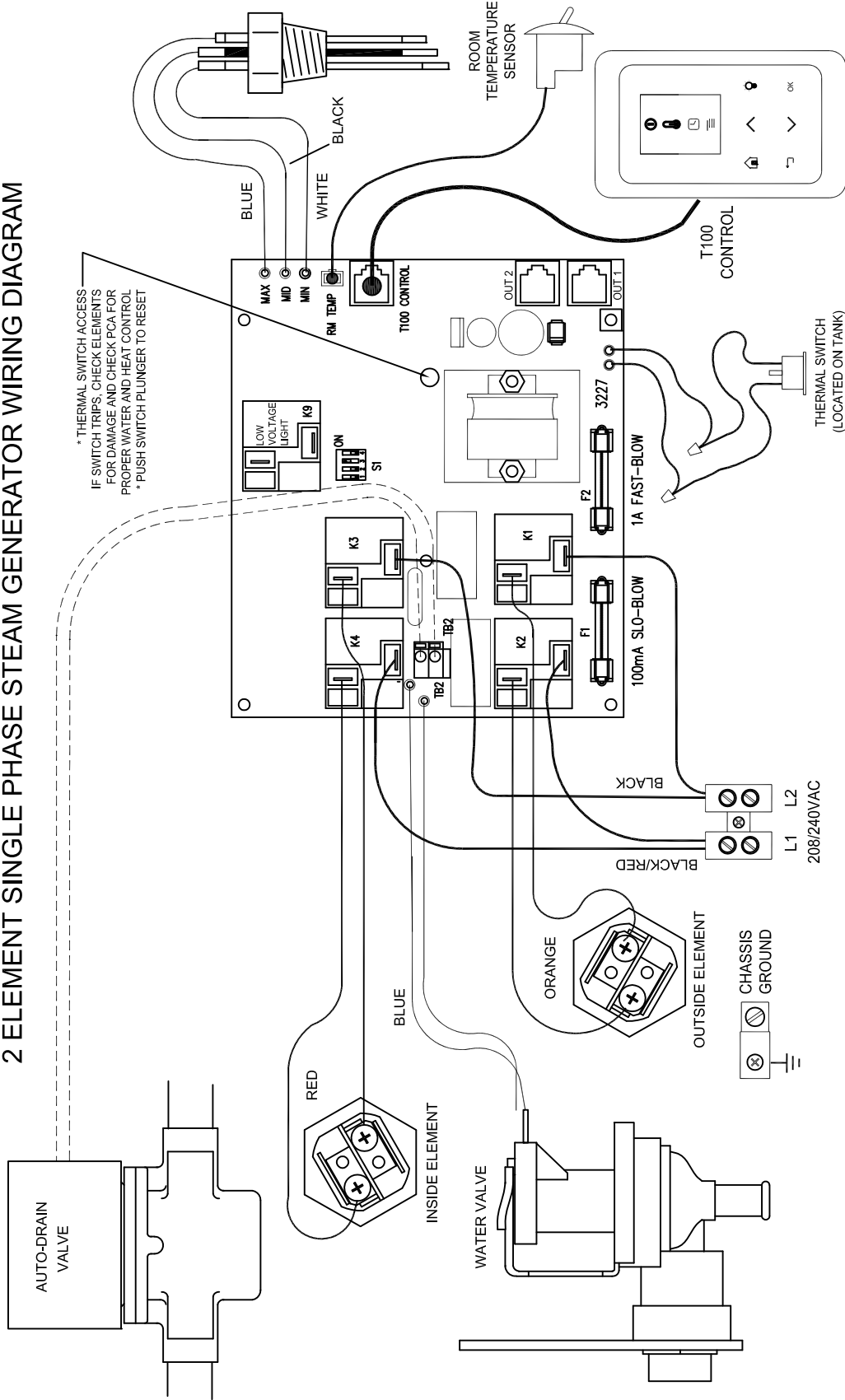
- When ordering parts, please provide the number, description and quantity needed. When ordering wires or wire assemblies, please describe the wires by color, location and/or their connection points.

- Do not return any material without first contacting Technical Support for a Return Authorization Number. Freight must be prepaid to the Factory.

**amerec**

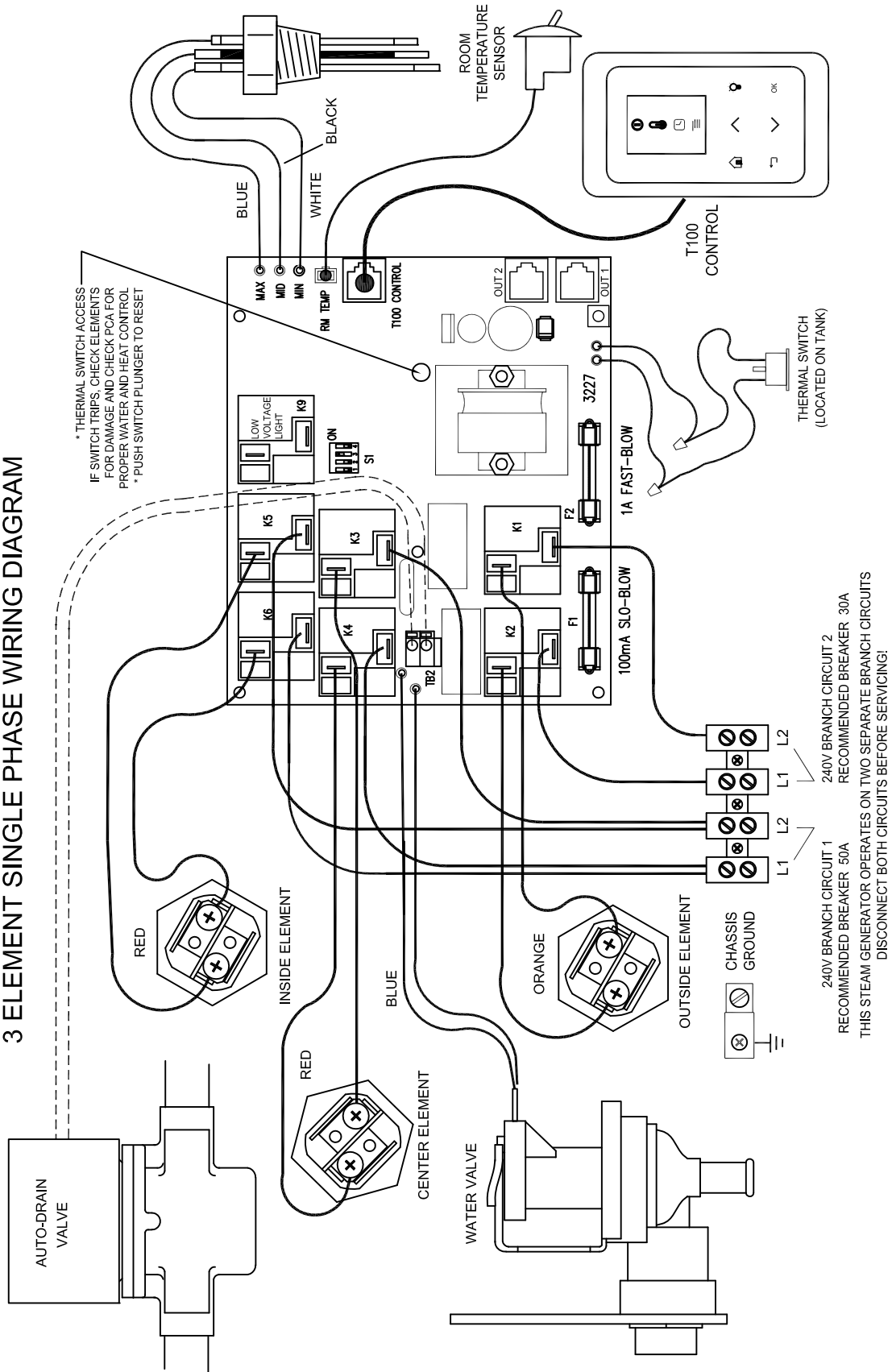
Technical Support  
 PO Box 2258  
 Woodinville, WA 98072  
 Phone 425-951-1163  
 FAX 425-951-1130  
 email: support@amerec.com

2 ELEMENT SINGLE PHASE STEAM GENERATOR WIRING DIAGRAM

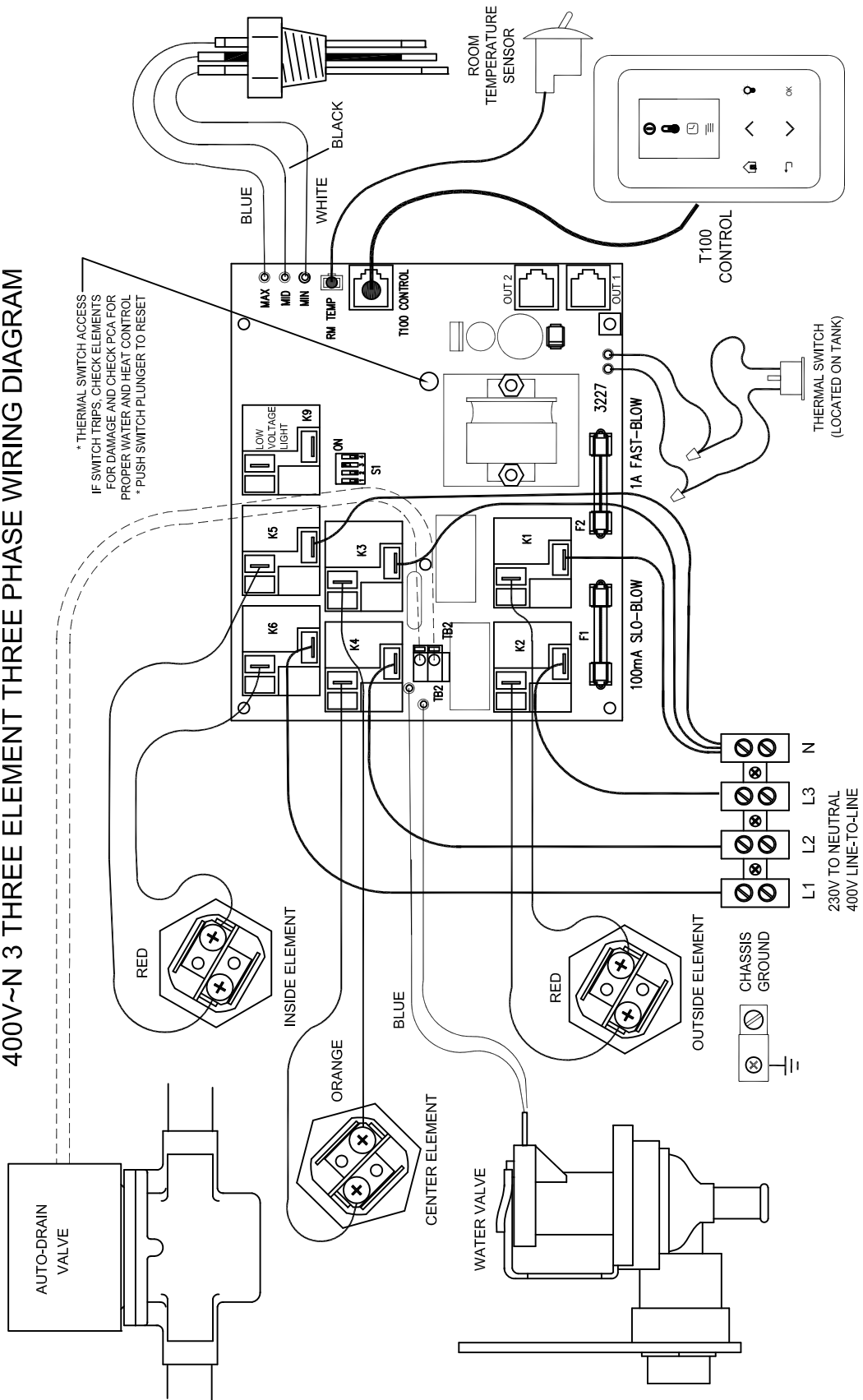




3 ELEMENT SINGLE PHASE WIRING DIAGRAM



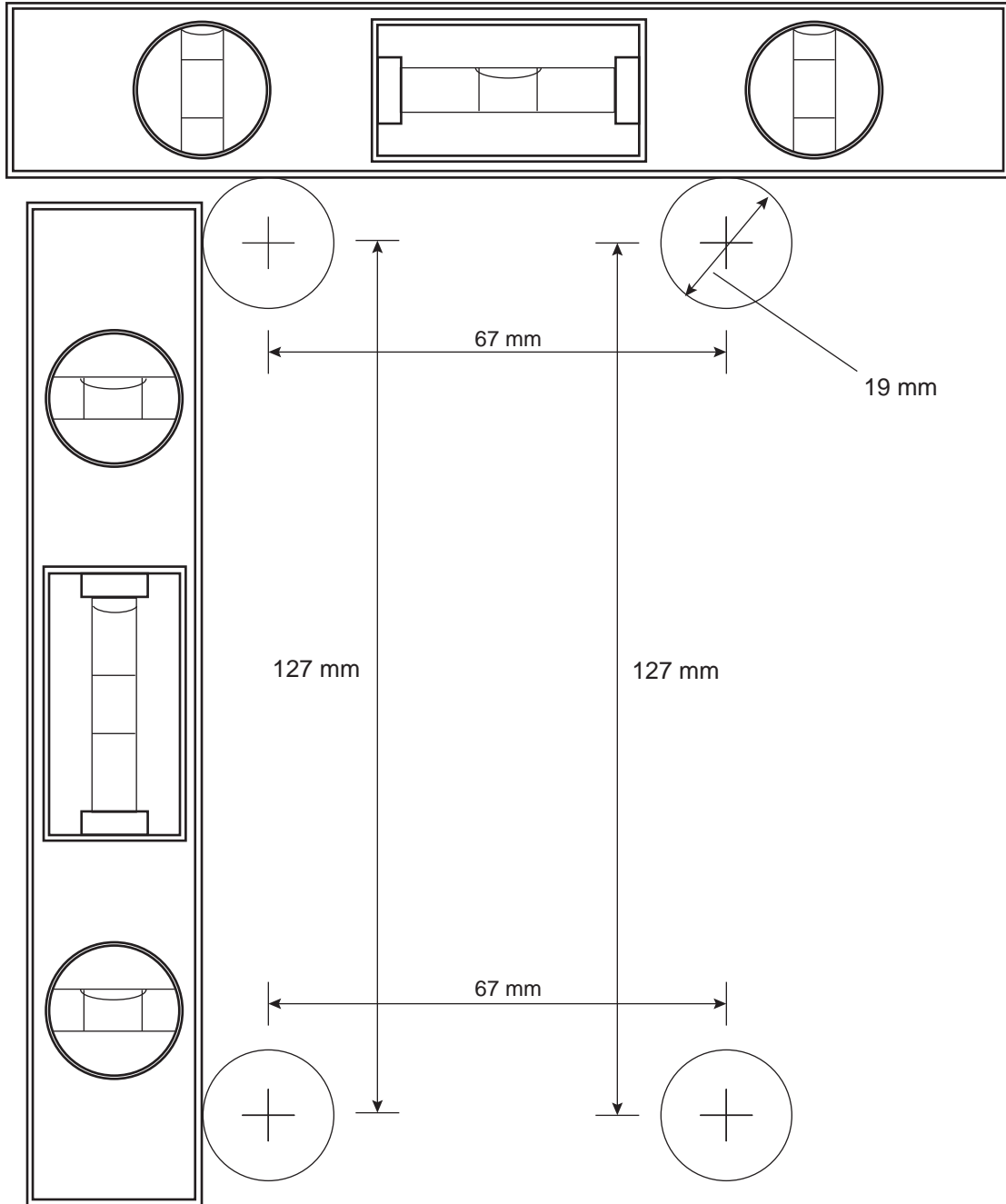
400V~N 3 THREE ELEMENT THREE PHASE WIRING DIAGRAM



### T100 Rough-in: Step 1

Drill four 19 mm holes, level and plumb as shown below

*Always confirm pattern as printed is to scale before using as a template.  
Some printers will change pattern size during printing.*



### T100 Rough-in: Step 2

Cut straight edges from hole to hole as shown.

Note: *dashed line shows outside edge of T100 control for reference.*

*Always confirm pattern as printed is to scale before using as a template.  
Some printers will change pattern size during printing.*

