

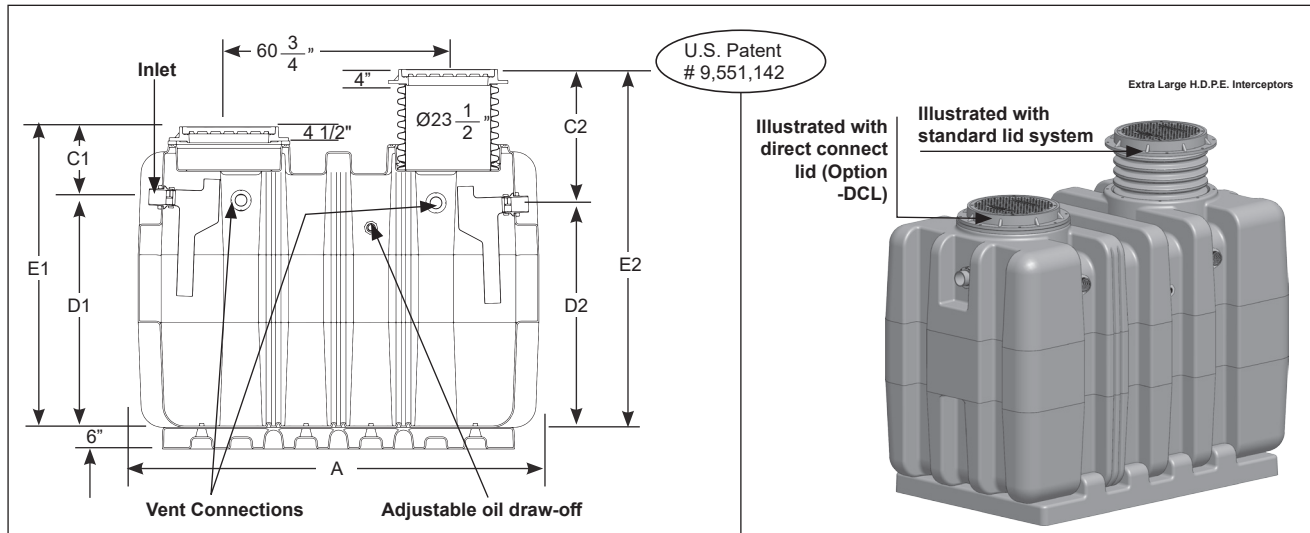

**Specification:** Town & Country Plastics OI-SS-1500 oil interceptor with 1500 U.S. gallons of liquid holding capacity has a limited lifetime warranty and is made in the U.S.A. out of seamless, rotationally molded High Density Polyethylene with 3/8" uniform wall thickness. Interceptor is designed for above or below ground installation and includes an adjustable lid system, sample port access, deep seal trap covered by lid, internal air relief by-pass, adjustable oil draw-off assembly (1 1/2" I.P.S.) on each side, double vent connections (3" I.P.S.) on each side, stainless steel calibrated orifice plate (internal flow control), base for support and floor level installation and 4" no hub inlet and outlet connections. Steel encased composite lids provide a water / gas tight seal and have a minimum of 20,000 LB. load capacity - in accordance with the loading requirements of AASHTO H20. The high density polyethylene material is PE 3135 from Dow 9.39 with a density of 0.939 g/cm<sup>3</sup>.

**Function:** Oil interceptors are required anywhere oil and sand may be introduced to the public sewer system in applications such as: repair garages, oil change stations, car wash facilities, parking garages, parking lots, hydraulic elevator pits and facilities where oil and flammable liquid waste are produced as a result of manufacturing, storage, maintenance, repair or testing processes. The interceptor collects the oil before it is drained to an adjacent storage tank through an adjustable draw off system. Sediment and debris are collected inside of the internal sediment bucket. Typically installed either on or into the floor. Regular maintenance is required to keep the interceptor functioning.



Model	Liquid Holding Capacity	Flow Rate (GPM)	A	Width B	C <sup>1</sup> Dim.	C <sup>2</sup> Dim.	D <sup>1</sup> Dim.	D <sup>2</sup> Dim.	E <sup>1</sup> Dim.	E <sup>2</sup> Dim.	F Connection Size	Shipping Weight (Lbs.)
OI-SS-1500	1500 U.S. Gallons 5,680 litres	250	111" 2820mm	64" 1630mm	18.75" 476mm	37.25" 946mm	64" 1626mm	62" 1575mm	82.75" 2102mm	99.25" 2521mm	4" 102mm	1,260

Suffix	Optional Variations
-AK	High water anchor kit (set of two)
-C	Lid extension (specify dimension required)
-COA	Coalescer Pack
-DI	Ductile iron lid & collar
-EP	Enzyme port
-FL-C	Membrane clamp kit
-F6	6" No Hub Inlet / Outlet connection (flow rate of 700 GPM with 6" connections)
-HLA	High level alarm and float switch (to be installed on site)
-HT	Holding Tank
-LHSI	4" no hub inlet on left hand side
-LHSO	4" no hub outlet on left hand side
-RHSI	4" no hub inlet on right hand side
-RHSO	4" no hub outlet on right hand side
-RPO	4" Remote pump outlet connections on top of interceptor - specify location and number required
-SB	Sediment bucket
-SP	External Sample Port (for existing construction. Inlet and Outlet on the same level)
-SP-OF	External Sample Port (for new construction. Inlet higher than the outlet).
-SST	Fire resistant fabricated stainless steel interceptor
-ST	Fire resistant fabricated 10 gauge powder epoxy coated steel interceptor

Design and dimensions are subject to modification.

Visit [www.tandcplastics.com](http://www.tandcplastics.com) for the most recent product information.