

# WALKER

## Illustrated Parts Manual

Side Discharge Deck and Carrier Frame Assemblies

DS36

DS42

DS48

DS52

DR52

DS56

DS60

DS62

DS74

DS42 Belt Drive

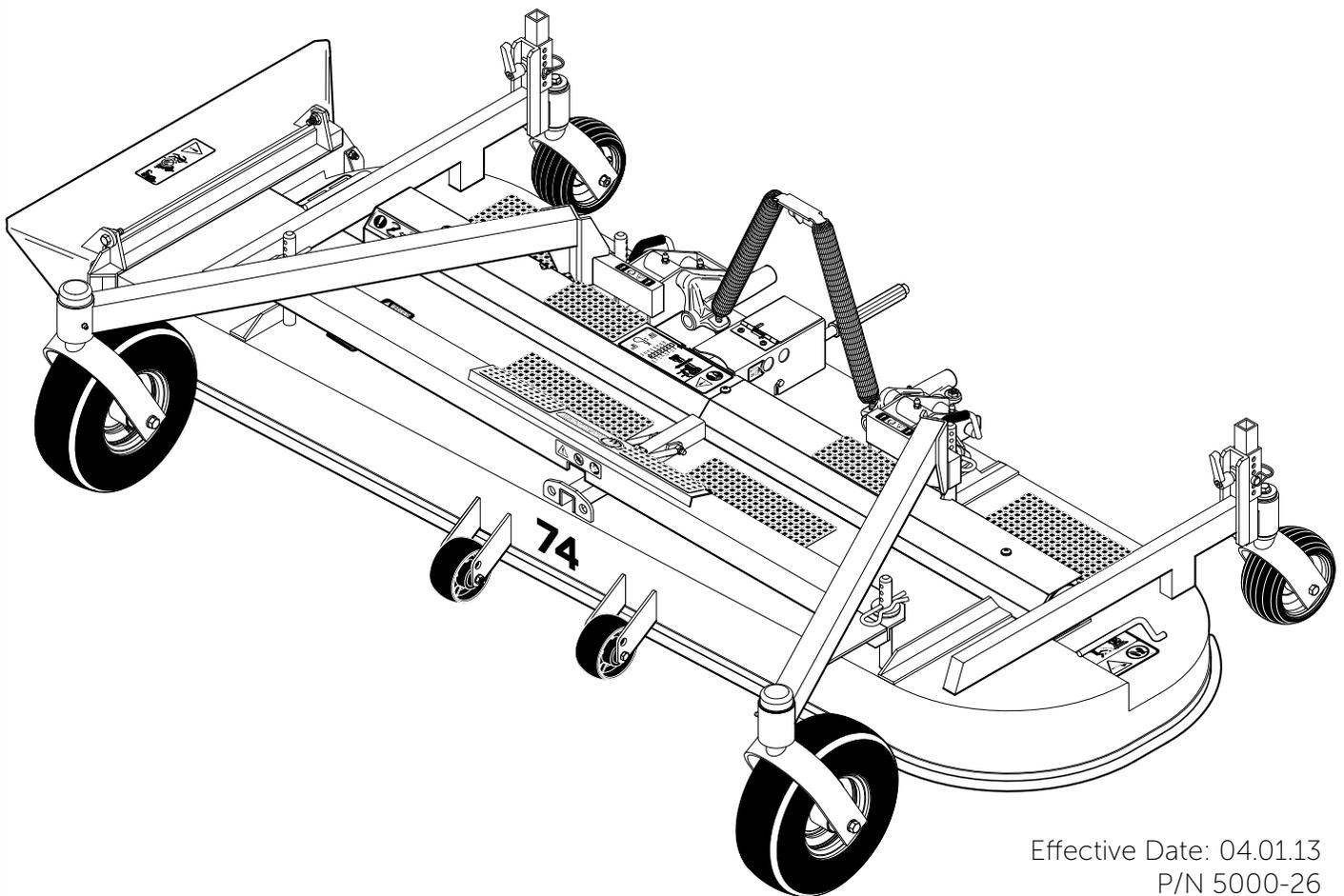

Effective Date: 04.01.13  
P/N 5000-26

# KEY TO ABBREVIATIONS USED IN THIS MANUAL

<i>Abbreviation</i>	<i>What it Represents</i>
° (Dimension)	Degrees (Angle)
" (Dimension)	inches
(-)	Negative (Polarity)
(+)	Positive (Polarity)
AT	All-Terrain
CCW	Counter-clockwise
Conn	Connector
CW	Clockwise
D	Diameter
DC	Deck, Collection (number refers to size in inches)
DM	Deck, Mulching (number refers to size in inches)
DR	Deck, Rear Discharge (number refers to size in inches)
DS	Deck, Side Discharge (number refers to size in inches)
DU	Garlock (Bearing)
ESNA (Fastener)	Nylon Insert Locknut
FSC	Forward Speed Control
GA	Gauge
gal	gallon
GHS	Grass Handling System
GR (Fastener)	Grade
HD	Heavy Duty
HP	Horse Power
ID	Identification or Inside Diameter
L	Length
LH	Left Hand (orientated with operator on seat)
LP	Low Profile
mm (Dimension)	millimeters
MS (Fastener)	Machine Screw
NS (as part number)	Item is not sold by Walker Manufacturing
OD	Outside Diameter
oz	ounce
PFH (Fastener)	Phillips Flat Head
P/N	Part Number
PPH (Fastener)	Phillips Pan Head
PTH (Fastener)	Phillips Truss Head
PTO	Power Take-Off
QKS	Quick Slide
qt	quart
RH	Right Hand (orientated with operator on seat)
SAE (Fastener)	Society of Automotive Engineers
SBH (Fastener)	Socket Button Head (Bolt)
SD	Side Discharge
SFH (Fastener)	Slotted Flat Head
SHC (Fastener)	Socket Head Cap
SHL (Fastener)	Shoulder (Bolt)
SM (Fastener)	Sheet Metal (Screw)
S/N	Serial Number
Spg	Spring
SQH (Fastener)	Square Head
SS (Fastener)	Stainless Steel
ST (Fastener)	Self-Tapping (Screw)
Term	Terminal
V	Volts

**NOTE:** In some instances, combinations of abbreviations may be used (e.g. PPHMS - Phillips Pan Head Machine Screw).

# ILLUSTRATED PARTS LIST

<i>Section of Deck Covered</i>	<i>Page</i>	<i>Section of Deck Covered</i>	<i>Page</i>
<b>Decals &amp; Paint</b>		<b>Maintenance</b>	
36", 42", 42 Belt Drive, 48", 52" & 56" Deck Decals ...	2	Optional Break-Away Blades .....	52
DR52 & DS60 Deck Decals .....	4	Blade Usage Chart .....	53
62" & 74" Deck Decals / Touch-Up Paint .....	6	Lubrication Points .....	54
<b>Deck and Carrier Frame Assemblies</b>		Fastener Loctite® Application & Torque Instructions .....	58
36 Inch Complete Carrier Frame Assembly .....	8	Maintenance And Service Record Sheet .....	60
DS36 Deck Assembly .....	10	Deck / Tractor Compatibility Chart .....	60
42 Inch Complete Carrier Frame Assembly .....	12		
DS42 Deck Assembly .....	14	<b>Warranty</b>	
42 Inch Belt Drive Complete Carrier Frame Assembly .....	16	Limited Warranty .....	61
DS42 Belt Drive Deck Assembly .....	18		
48 Inch Complete Carrier Frame Assembly .....	20		
DS48 Deck Assembly .....	22		
52 Inch Complete Carrier Frame Assembly .....	24		
DS52 Deck Assembly .....	26		
DS52 Mulching Kit .....	28		
52 Inch Complete Carrier Frame Assembly .....	30		
DR52 Deck Assembly .....	32		
56 Inch Complete Carrier Frame Assembly .....	34		
DS56 Deck Assembly .....	36		
60 Inch Complete Carrier Frame Assembly .....	38		
DS60 Deck Assembly .....	40		
DS60 Mulching Kit .....	42		
62 Inch Complete Carrier Frame Assembly .....	44		
DS62 Deck Assembly .....	46		
74 Inch Complete Carrier Frame Assembly .....	48		
DS74 Deck Assembly .....	50		

## 36", 42", 42 BELT DRIVE, 48", 52" & 56" DECK DECALS

ITEM NO.	PART NO.	DESCRIPTION	LOCATION	NO. REQ'D
<b>DS36, DS42, DS48 &amp; DS56 Deck Decals</b>				
1	8600-15	Caution, Pivot Joint	Carrier Frame	2
2	6875	PTO Alignment Arrow	Universal Joint Shaft Assembly	1
3	5846-1	Grease Fitting	PTO Shaft Guard	1
4	8600-7	Cutting Height Adjustment	Gearbox Cover	1
5	6789	Decal (56")	Carrier Frame	1
6	8600-28	Danger, Rotating Blades	Deck Housing (one on each end)	2
7	8821-14	Decal (36")	Carrier Frame	1
	8821-15	Decal (42")	Carrier Frame	1
	8821-16	Decal (48")	Carrier Frame	1
8	5809-2	Decal, Walker	Carrier Frame	1
9	8600-14	Danger, Tilt-Up	Carrier Frame, Front	1
10	8653-1	Transport Warning, DS56	Deck Housing	1
11	8600-9	Blade Mounting Torque	Gearbox Cover	1
12	5848-2	Danger, Side Discharge Shield	Side Discharge Shield	1
13	5848-1	Danger, Side Discharge, DS42	Side Discharge Shield	1
<b>DS42 Belt Drive Deck Decals</b>				
1	8600-15	Caution, Pivot Joint	Carrier Frame	2
2	6875	PTO Alignment Arrow	Universal Joint Shaft Assembly	1
3	5846-1	Grease Fitting	PTO Shaft Guard	1
4	8600-7	Cutting Height Adjustment	Footrest	1
6	8600-28	Danger, Rotating Blades	Deck Housing (one on each end)	2
7	8821-15	Decal (42")	Carrier Frame	1
8	5809-2	Decal, Walker	Footrest	1
9	8600-14	Danger, Tilt-Up	Carrier Frame, Front	1
11	8600-9	Blade Mounting Torque	Carrier Frame	1
12	5848-2	Danger, Side Discharge Shield	Side Discharge Shield	1
14	8749-1	Belt Routing	Deck Housing	1
<b>DS52 Deck Decals</b>				
1	8600-15	Caution, Pivot Joint	Carrier Frame	2
6	8600-28	Danger, Rotating Blades	Cover Plate (one on each end)	2
8	5809-2	Decal, Walker	Carrier Frame, Front	1
9	8600-14	Danger, Tilt-Up	Deck Housing, Front	1
10	8653-1	Transport Warning	Deck Housing	1
12	5848-2	Danger, Side Discharge Shield	Side Discharge Shield	1
15	8748	Cutting Height Adjustment	Footrest Pulley Guard	1
16	8746-2	Universal Joint Lube	PTO Cover Plate	1
17	8746-1	Decal, Tele PTO Shaft	Universal Joint Shaft Assembly	1
18	8732	Decal (52")	Deck Housing	1
19	8734	Drive Belt Routing	Underneath Deck Cover Plate	1

**NOTE:** All parts requiring decals are shipped with decals applied.

# 36", 42", 42 BELT DRIVE, 48", 52" & 56" DECK DECALS

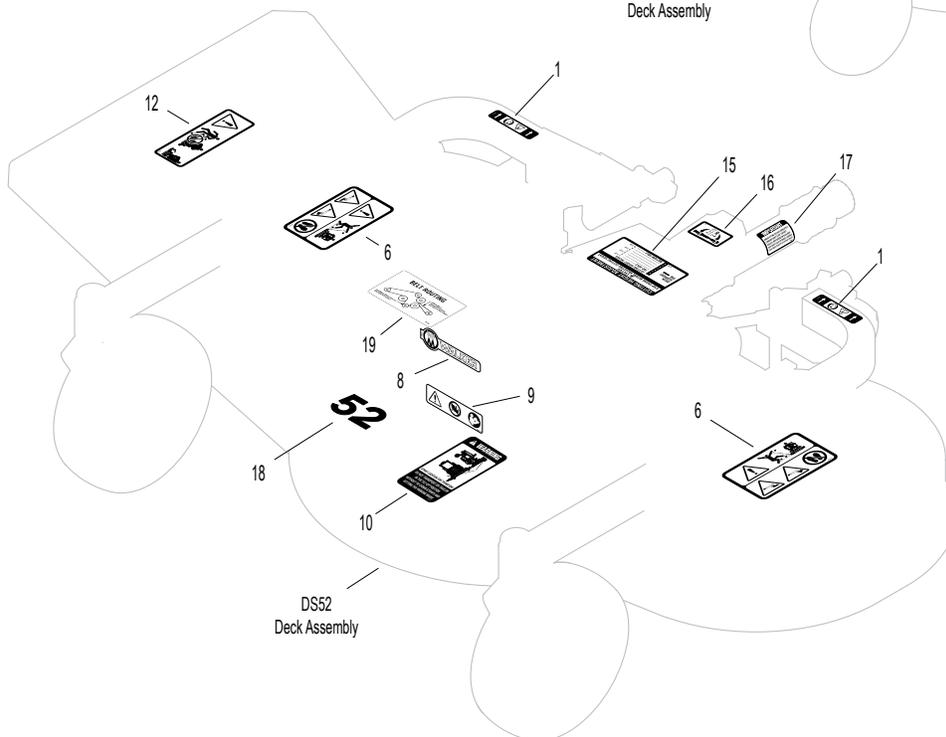
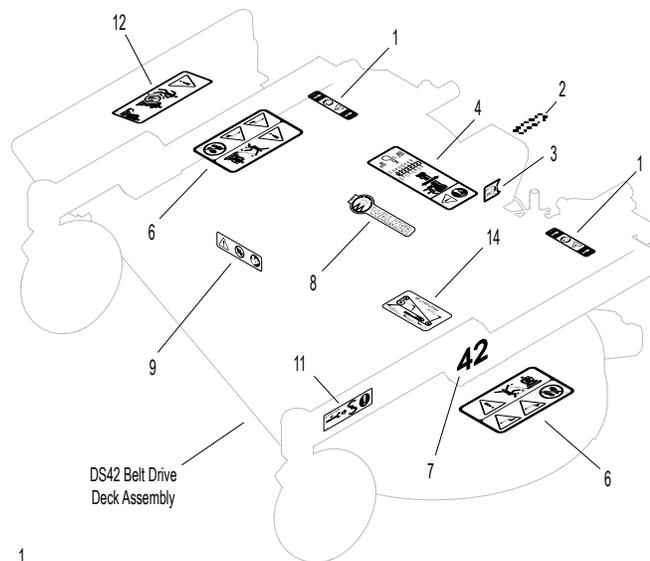
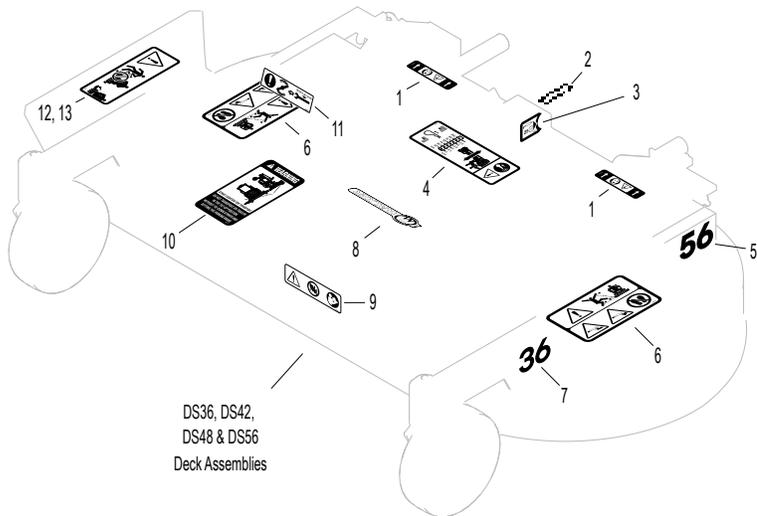

# DR52 & DS60 DECK DECALS

ITEM NO.	PART NO.	DESCRIPTION	LOCATION	NO. REQ'D
<b>DR52 Deck Decals</b>				
1	8600-15	Caution, Pivot Joint	Carrier Frame	2
2	6875	PTO Alignment Arrow	Universal Joint Tube Assembly	1
3	8600-28	Danger, Rotating Blades	Deck Housing (one on each end)	2
4	8600-14	Danger, Tilt-Up	Carrier Frame	1
5	8732	Decal (52")	Deck Housing, Front	1
6	2749-3	Decal, Drive Belt Routing	Deck Housing	1
7	5800-8	Decal, Walker 14"	Deck Footrest, Front	1
8	8653-1	Transport Warning	Spindle Cover	1
9	8746-2	Universal Joint Lube	PTO Guard Cover	1
10	2748-1	Cutting Height Adjustment	Carrier Frame	1
<b>DS60 Deck Decals</b>				
1	8600-15	Caution, Pivot Joint	Carrier Frame	2
2	6875	PTO Alignment Arrow	Universal Joint Tube Assembly	1
3	8600-28	Danger, Rotating Blades	Deck Housing (one on each end)	2
4	8600-14	Danger, Tilt-Up	Carrier Frame	1
6	2749-3	Decal, Drive Belt Routing	Deck Housing	1
7	5800-8	Decal, Walker 14"	Deck Footrest, Front	1
8	8653-1	Transport Warning	Spindle Cover	1
9	8746-2	Universal Joint Lube	PTO Guard Cover	1
10	2748-1	Cutting Height Adjustment	Carrier Frame	1
11	2732	Decal (60")	Deck Housing, Front	1
12	5848-2	Danger, Side Discharge Shield	Side Discharge Shield	1

**NOTE:** All parts requiring decals are shipped with decals applied.

# DR52 & DS60 DECK DECALS

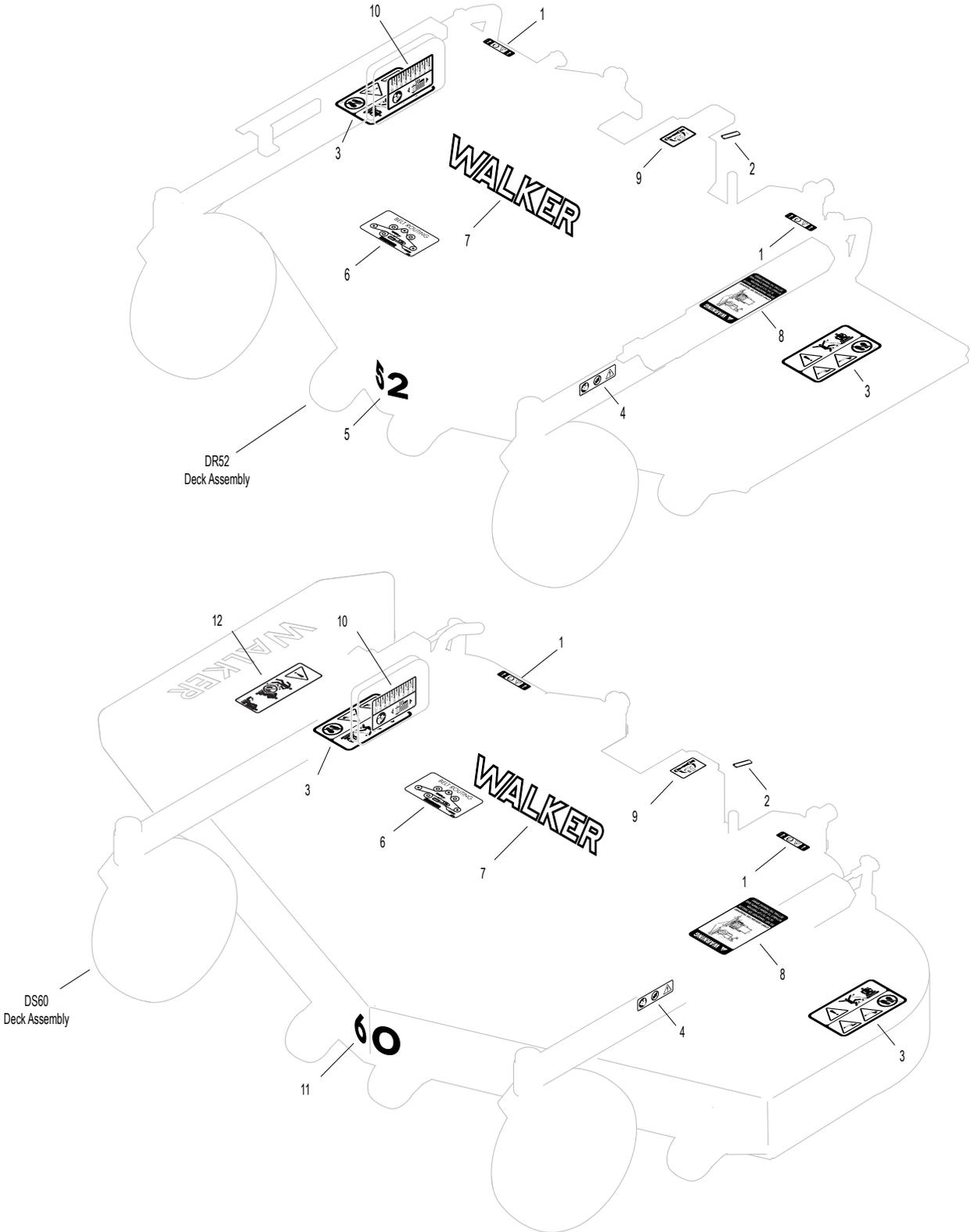

## 62" & 74" DECK DECALS / TOUCH-UP PAINT

ITEM NO.	PART NO.	DESCRIPTION	LOCATION	NO. REQ'D
<b>DS62 Deck Decals</b>				
1	8600-15	Caution, Pivot Joint	Carrier Frame	2
2	8746-2	Universal Joint Lube	PTO Cover Plate	1
3	8653-1	Transport Warning	Deck Housing	1
4	8600-28	Danger, Rotating Blades	Cover Plate (one on each end)	2
5	8600-14	Danger, Tilt-Up	Carrier Frame, Front	1
6	5848-2	Danger, Side Discharge Shield	Side Discharge Shield	1
7	8748	Cutting Height Adjustment	Footrest Pulley Guard	1
8	8746-1	Decal, Tele PTO Shaft	Universal Joint Shaft Assembly	1
9	5809-2	Decal, Walker	Carrier Frame, Front	1
10	8749	Drive Belt Routing	Underneath Deck Cover Plate	1
11	8750	Decal (62")	Deck Housing	1

### DS74 Deck Decals

1	8600-15	Caution, Pivot Joint	Carrier Frame	2
3	8653-1	Transport Warning	Deck Housing	1
4	8600-28	Danger, Rotating Blades	Deck Housing (one on each end)	2
5	8600-14	Danger, Tilt-Up	Carrier Frame, Front	1
6	5848-2	Danger, Side Discharge Shield	Side Discharge Shield	1
9	5809-2	Decal, Walker	Carrier Frame	1
12	6875	PTO Alignment Arrow	Universal Joint Shaft Assembly	1
13	5846-1	Grease Fitting	PTO Shaft Guard	1
14	8600-7	Cutting Height Adjustment	Gearbox Cover, RH	1
15	7689	Decal (74")	Deck Housing, Front	1
16	8600-9	Blade Mounting Torque	Gearbox Cover, RH	1

### Touch-Up Paint

17	5866	Touch-Up Paint, Yellow (12 oz. Aerosol)		
----	------	---	--	--

**NOTE:** All parts requiring decals are shipped with decals applied.

# 62" & 74" DECK DECALS / TOUCH-UP PAINT

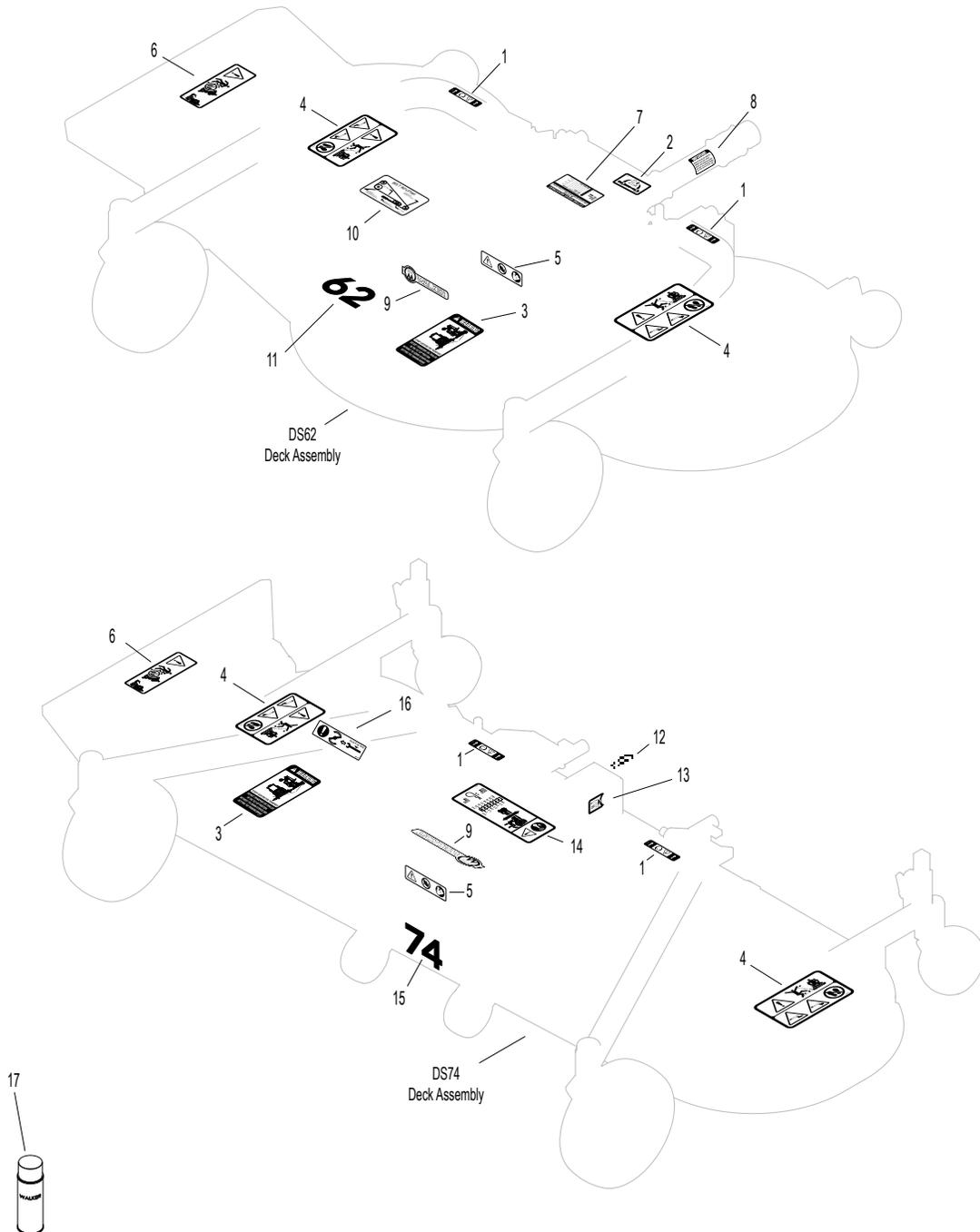

# 36 INCH COMPLETE CARRIER FRAME ASSEMBLY

ITEM NO.	PART NO.	DESCRIPTION	NO. REQ'D	ITEM NO.	PART NO.	DESCRIPTION	NO. REQ'D
<b>Spring and Pivot Mount Components</b>				<b>Fasteners</b>			
1	5975-3	Cable Tie (50# x 7")	4	F012		3/8-16 Keps Nut	2
2	5744-1	Spring Clip Bracket	1	F020		5/16-18 ESNA Nut	2
3	5743-1	Spring Cover	2	F047		3/8-16 x 4-1/2 Hex Bolt	2
4	5830	Grease Fitting	8	F055		5/8 SAE Washer	2
5	8667-29	Pivot Mount Adj., LH	1	F068		1/8 x 1 Cotter Pin	2
	8667-3	Pivot Mount Assembly, LH/Adj. (Includes Items # 4, 5, F353, F489 & F520)	*	F084		5/16 Wave Spring Washer	2
6	8667-28	Pivot Mount Adj., RH	1	F098		5/8-18 Slotted Hex Nut	2
	8667-4	Pivot Mount Assembly, RH/Adj. (Includes Items # 4, 6, F353, F489 & F520)	*	F117		Retainer Ring	2
7	5743-4	Eyebolt (3/8-16 x 2-3/4)	2	F123		1" External Snap Ring	4
8	5743-8	Extension Spring (1-1/2 x 7-3/4) (Includes Items # 1, F117 & F166)	2	F166		Retainer Ring	2
				F226		5/16-18 x 7/8 Hex Bolt	2
				F317		3/16 x 1 Split Spring Pin	2
				F335		3/8-16 x 7/8 Set Screw, SS	2
				F336		3/8-16 Jam Nut	2
				F353		3/8-16 ESNA LP Nut	2
				F489		Washer 1/4 x 7/8 x .090	2
				F520		1/4-28 x 3/8 Hex Bolt	2
<b>Carrier Frame Components</b>				* Service Part Only			
9	8674-11	Lever, Deck Lock, LH	1	** May be ordered as a kit for dealer installation. Contact your Walker dealer.			
10	7406-1	Handle Grip (Red)	2	<b>NOTE:</b> When installing Item # 8 on decks prior to S/N DX-62875, the swivel hook end should be attached to the deck carrier frame.			
11	8669	Lift Handle	1				
12	5748-10	Rubber Mat (1-1/2 x 6)	2				
13	5740-2	Deck Pin Bushing (5/8)	4				
14	5708-6	36" Carrier Frame (Less Pivots) (Includes Item # 12)	1				
	5708-1	36" Carrier Frame w/Forks (Less Pivots) (Includes Items # 12, 21-23, 25, F055, F068 & F098)	*				
15	8674-10	Lever, Deck Lock, RH	1				
<b>Caster Wheel Components</b>							
16	5714-7	Bearing Cap	4				
17	5714-5	Bearing, Caster Wheel	2				
18	5830-3	Grease Fitting (45 Degree)	2				
19	5715-4	Caster Wheel, Pneumatic (8 x 3.00-4) (Includes Items # 16-18)	2				
	5715-10	Tire, Pneumatic (8 x 3.00-4)	*				
	5715-9	Tire Tube, Pneumatic (2.80/2.50-4)	*				
	5715-3	Caster Wheel & Tire/No-Flat (8 x 3.00-4)	**				
	5715-11	Tire, Caster Wheel/No-Flat (8 x 3.00-4)	**				
20	5714-3	Axle Spacer Tube	2				
21	5770-1	Caster Wheel Fork	2				
22	8768-1	Seal (1-3/4 x 1-1/8)	2				
23	8037	Bearing Cone (3/4 ID)	4				
24	8769-1	Bearing Cup (1-3/4 x 1-7/16)	4				
25	8769-9	Dust Cap, Deck Caster	2				

# 36 INCH COMPLETE CARRIER FRAME ASSEMBLY

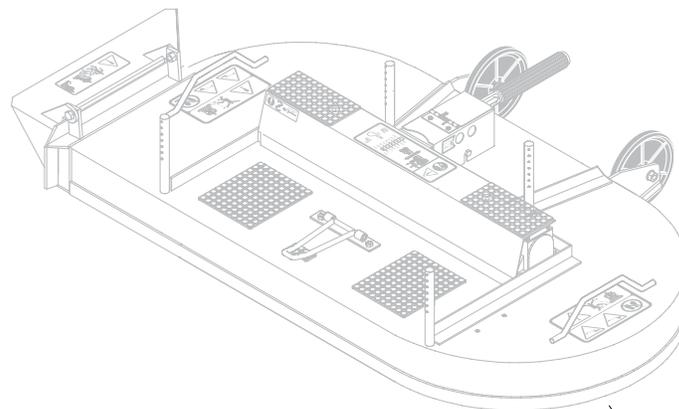
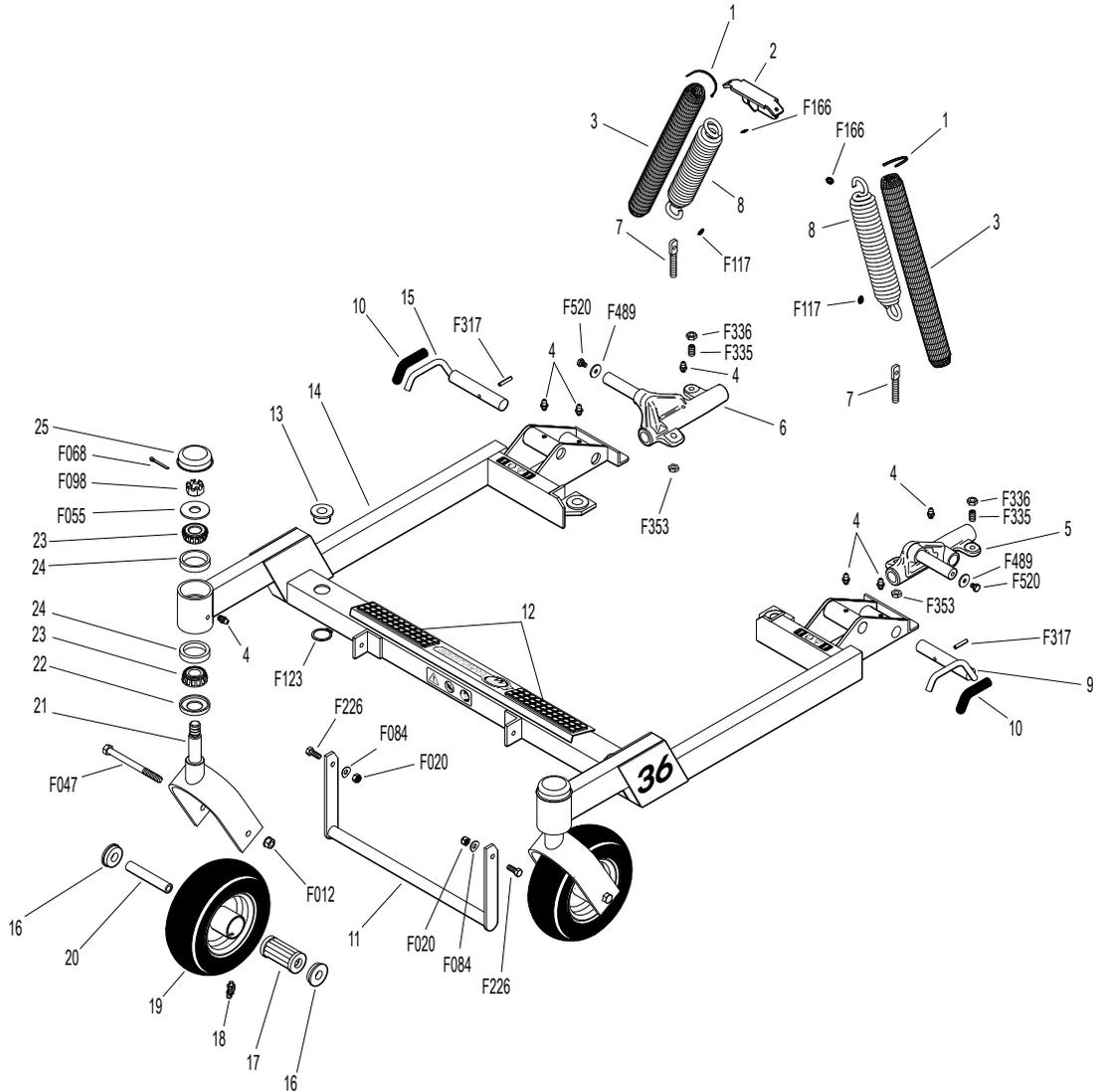

Refer to DS36  
DECK ASSEMBLY, Page 10  
Refer to LUBRICATION POINTS, Page 54.

# DS36 DECK ASSEMBLY

## INCL. OPTIONAL HD GEARBOXES

ITEM NO.	PART NO.	DESCRIPTION	NO. REQ'D	ITEM NO.	PART NO.	DESCRIPTION	NO. REQ'D
<b>Gearbox and Drive Components</b>				28	5706	Blade Hub & Trash Guard	2
1	8618-1	Cover, PTO Shaft Guard	1	29	8735-10	Rubber Mat (5 x 6)	2
2	8619-2	PTO Shaft Guard	1	30	7775-1	Hitch Pin, LH (Silver) #6	2
	8618-3	PTO Shaft Guard Assembly (Includes Items # 1, 2, F002 & F025)	*	31	8788-1	Rubber Mat (1 x 2)	1
3	5285-15	U-Joint Shaft Assy, 90 Degree, Spline (Includes Items # 21, F069 & F295)	1	32	7775-2	Hitch Pin, RH (Gold) #6	2
4	7275-16	U-Joint Tube Assy, Spline	1	33	5709-2	36/42 SD Discharge Shield	1
5	5275-15	U-Joint Tube Assy (9.5" OAL), Spline (Includes Item # F076)	1	34	5727-1	Washer Shim (5/8 ID)	4
6	5704-43	Gearbox and Tube Assembly (Includes Items # 7-16, F124, F136, F179 & F211)	1	<b>Fasteners</b>			
	5704-46	HD Gearbox and Tube Assembly (Includes Items # 7, 9-16, F136, F179 & F211)	**	F002	10-24 Keps Nut		6
7	5704-1	Gearbox Cover Support	2	F004	1/4-20 Keps Nut		2
8	5706-4	Seal Protector Plate	2	F013	3/8-16 Whiz Locknut		6
9	6054	Spline Coupling	3	F014	3/8-16 ESNA Nut		2
10	P007	Gasket, Cap (Peerless #788030)	4	F018	5/8-18 Hex Nut		2
11	5061	Gearbox Connector Tube (6-11/16)	1	F025	10-24 x 3/8 PPHMS		2
12	6733-2	Connecting Shaft (4-1/8)	1	F029	1/4-20 x 1/2 Hex Bolt		2
13	5052-1	Gearbox (LH Rotation)	1	F038	3/8-16 x 1 Hex Bolt		4***
	5052-5	HD Gearbox (LH Rotation)	**	F039	3/8-16 x 1-1/4 Hex Bolt		6
14	5051-16	Tee Gearbox, Shear	1	F050	1/4 SAE Washer		4
	5051-6	HD Tee Gearbox, Shear	**	F055	5/8 SAE Washer		2
15	5060	Gearbox Connector Tube (2-5/16)	1	F056	5/8 Split Lock Washer		2
16	5053-1	Gearbox (RH Rotation)	1	F059	3/8 Wave Spring Washer		4
	5053-5	HD Gearbox (RH Rotation)	**	F069	3/32 x 1/2 Cotter Pin		1
17	5052-3	1.375 x .750 x .187 Washer	4	F076	3/8-16 x 5/8 SQH Set Screw		*
18	5747-11	Rubber Mat (3 x 6)	2	F124	10-32 x 3/8 Taptite Machine Screw		6
19	5746-4	36" Gearbox Cover (Includes Item # 18)	1	F136	AN960C416L Washer		16
20	5830	Grease Fitting	1	F179	1/4-20 x 1 Hex Bolt		4
21	8067-13	Shear Pin w/Cotter (Set of 5) (Includes Item # F069)	*	F202	10-24 x 5/8 SHC Screw, GR5 SS		4
<b>Deck Housing Components</b>				F206	#2 x 3/16 Drive Pin		2
22	8670	Tilt-Up Hook	1	F211	1/4-20 x 7/8 Hex Bolt		12
23	5162-11	Roller Wheel (5" Poly) (Includes Item # F059)	2	F246	1/4-20 x 1/2 PTHMS		2
24	8490	Roller Wheel Axle Bolt	2	F278	3/8 Split Lock Washer		4***
25	5710-18	36 SD Deck Housing (Includes Items # 23, 24, 29 & 31)	1	F295	3/16 x 1-1/2 Split Spring Pin		1
26	NS	Deck Serial Number Plate	1	F403	1/4-20 x 1/2 PTHMS, SS		2
27	5705-1	Blade, 20" (RH Rotation)	2	F517	Washer 3/8 x 1-1/8 x 1/8		4***
	5705-5	36 SD Blade Set W/Hubs (Includes Items # 27, 28, F002 & F202)	*	* Service Part Only			
				** Item(s) used on the HD version of standard gearboxes. The HD cast iron gearboxes are interchangeable with Standard aluminum gearboxes.			
				*** Used on HD gearbox configuration.			
				<b>NOTE:</b> Order Item # 4 to use the splined deck PTO shaft with Model T23, T25i, T30i, D21d, C19 and B19.			
				<b>NOTE:</b> Order Item # 5 to use the splined deck PTO shaft with Model S14 and B18.			

# DS36 DECK ASSEMBLY

## INCL. OPTIONAL HD GEARBOXES

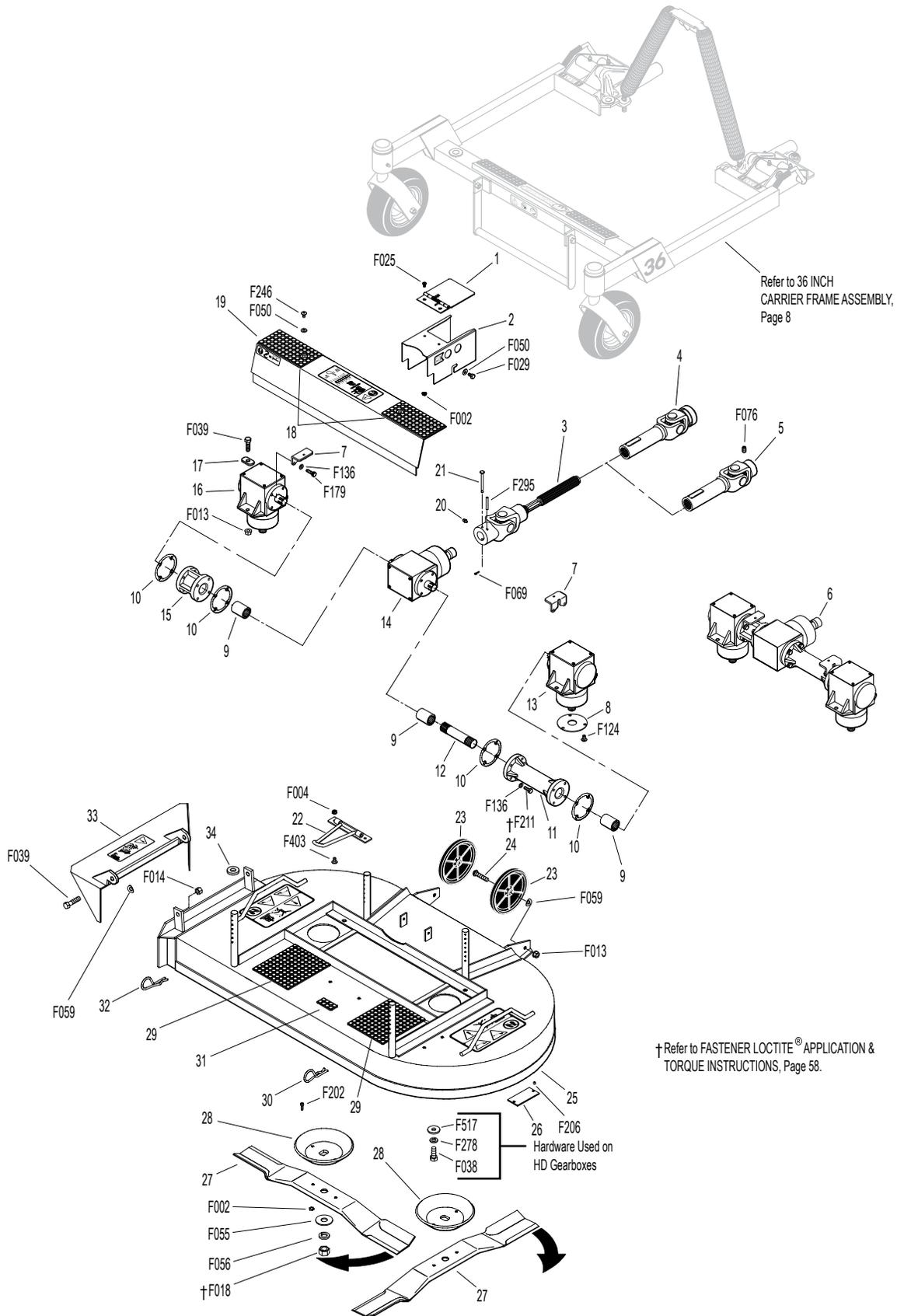

# 42 INCH COMPLETE CARRIER FRAME ASSEMBLY

ITEM NO.	PART NO.	DESCRIPTION	NO. REQ'D	ITEM NO.	PART NO.	DESCRIPTION	NO. REQ'D
<b>Spring and Pivot Mount Components</b>				<b>Fasteners</b>			
1	5975-3	Cable Tie (50# x 7")	4	F012		3/8-16 Keps Nut	2
2	5744-1	Spring Clip Bracket	1	F020		5/16-18 ESNA Nut	2
3	5743-1	Spring Cover	2	F047		3/8-16 x 4-1/2 Hex Bolt	2
4	5743-4	Eyebolt (3/8-16 x 2-3/4)	2	F055		5/8 SAE Washer	2
5	5830	Grease Fitting	8	F068		1/8 x 1 Cotter Pin	2
6	8667-29	Pivot Mount Adj., LH	1	F084		5/16 Wave Spring Washer	2
	8667-3	Pivot Mount Assembly, LH/Adj. (Includes Items # 5, 6, F353, F489 & F520)	*	F098		5/8-18 Slotted Hex Nut	2
7	8667-28	Pivot Mount Adj., RH	1	F117		Retainer Ring	2
	8667-4	Pivot Mount Assembly, RH/Adj. (Includes Items # 5, 7, F353, F489 & F520)	*	F123		1" External Snap Ring	4
8	5743-8	Extension Spring (1-1/2 x 7-3/4) (Includes Items # 1, F117 & F166)	2	F166		Retainer Ring	2
				F226		5/16-18 x 7/8 Hex Bolt	2
				F317		3/16 x 1 Split Spring Pin	2
				F335		3/8-16 x 7/8 Set Screw, SS	2
				F336		3/8-16 Jam Nut	2
				F353		3/8-16 ESNA LP Nut	2
				F489		Washer 1/4 x 7/8 x .090	2
				F520		1/4-28 x 3/8 Hex Bolt	2
<b>Carrier Frame Components</b>				* Service Part Only			
9	8674-11	Lever, Deck Lock, LH	1	** May be ordered as a kit for dealer installation. Contact your Walker dealer.			
10	7406-1	Handle Grip (Red)	2	<b>NOTE:</b> When installing Item # 8 on decks prior to S/N DX-62875, the swivel hook end should be attached to the deck carrier frame.			
11	8669-3	Lift Handle	1				
12	5748-10	Rubber Mat (1-1/2 x 6)	2				
13	5740-2	Deck Pin Bushing (5/8)	4				
14	8660-16	42" Carrier Frame w/Forks (Includes Items # 12, 21-23, 25, F055, F068 & F098)	1				
	8660-15	42" Carrier Frame (Includes Item # 12)	*				
15	8674-10	Lever, Deck Lock, RH	1				
<b>Caster Wheel Components</b>							
16	5714-7	Bearing Cap	4				
17	5714-5	Bearing, Caster Wheel	2				
18	5830-3	Grease Fitting (45 Degree)	2				
19	5715-4	Caster Wheel, Pneumatic (8 x 3.00-4) (Includes Items # 16-18)	2				
	5715-10	Tire, Pneumatic (8 x 3.00-4)	*				
	5715-9	Tire Tube, Pneumatic (2.80/2.50-4)	*				
	5715-3	Caster Wheel & Tire/No-Flat (8 x 3.00-4)	**				
	5715-11	Tire, Caster Wheel/No-Flat (8 x 3.00-4)	**				
20	5714-3	Axle Spacer Tube	2				
21	5770-1	Caster Wheel Fork	2				
22	8768-1	Seal (1-3/4 x 1-1/8)	2				
23	8037	Bearing Cone (3/4 ID)	4				
24	8769-1	Bearing Cup (1-3/4 x 1-7/16)	4				
25	8769-9	Dust Cap, Deck Caster	2				



# DS42 DECK ASSEMBLY

## INCL. OPTIONAL HD GEARBOXES

ITEM NO.	PART NO.	DESCRIPTION	NO. REQ'D	ITEM NO.	PART NO.	DESCRIPTION	NO. REQ'D
<b>Gearbox and Drive Components</b>				32	5703-15	42 SD Deck Housing (Includes Items # 30 & 31)	1
1	8618-1	Cover, PTO Shaft Guard	1	33	7775-2	Hitch Pin, RH (Gold) #6	2
2	8619	PTO Shaft Guard	1	34	5709-12	Front Back Up Plate	1
	8618	PTO Shaft Guard Assembly (Includes Items # 1, 2, F002 & F025)	*	35	5709-11	Center Backup Plate	1
3	5285-15	U-Joint Shaft Assy, 90 Degree, Spline (Includes Items # 22, F069 & F295)	1	36	5709-13	Rear Back Up Plate	1
4	7275-16	U-Joint Tube Assy, Spline	1	37	5709-8	Rubber Shield	1
5	5275-15	U-Joint Tube Assy (9.5" OAL), Spline (Includes Item # F076)	1	38	5709-14	42 SD Discharge Shield	1
6	5704-51	Gearbox and Tube Assembly (Includes Items # 7-17, F124, F136, F179 & F211)	1	39	5727-1	Washer Shim (5/8 ID)	4
	5704-54	HD Gearbox and Tube Assembly (Includes Items # 8-17, F136, F179 & F211)	**	<b>Fasteners</b>			
7	5706-4	Seal Protector Plate	2	F002	10-24 Keps Nut		6
8	6054	Spline Coupling	4	F004	1/4-20 Keps Nut		2
9	P007	Gasket, Cap (Peerless #788030)	4	F005	1/4-20 ESNA Nut		9
10	5063	Gearbox Connector Tube (8-5/8)	1	F013	3/8-16 Whiz Locknut		6
11	6733-3	Connecting Shaft (6-1/4)	1	F014	3/8-16 ESNA Nut		2
12	5052-1	Gearbox (LH Rotation)	1	F018	5/8-18 Hex Nut		2
	5052-5	HD Gearbox (LH Rotation)	**	F025	10-24 x 3/8 PPHMS		2
13	5704-1	Gearbox Cover Support	2	F029	1/4-20 x 1/2 Hex Bolt		2
14	5051-16	Tee Gearbox, Shear	1	F038	3/8-16 x 1 Hex Bolt		4***
	5051-6	HD Tee Gearbox, Shear	**	F039	3/8-16 x 1-1/4 Hex Bolt		6
15	6733-1	Connecting Shaft (2")	1	F050	1/4 SAE Washer		4
16	5062	Gearbox Connector Tube (4-3/8)	1	F055	5/8 SAE Washer		2
17	5053-1	Gearbox (RH Rotation)	1	F056	5/8 Split Lock Washer		2
	5053-5	HD Gearbox (RH Rotation)	**	F059	3/8 Wave Spring Washer		4
18	5052-3	1.375 x .750 x .187 Washer	4	F069	3/32 x 1/2 Cotter Pin		1
19	5747-11	Rubber Mat (3 x 6)	2	F076	3/8-16 x 5/8 SQH Set Screw		*
20	5785-5	42" Gearbox Cover (Includes Item # 19)	1	F124	10-32 x 3/8 Taptite Machine Screw		6
21	5830	Grease Fitting	1	F136	AN960C416L Washer		16
22	8067-13	Shear Pin w/Cotter (Set of 5) (Includes Item # F069)	*	F179	1/4-20 x 1 Hex Bolt		4
<b>Deck Housing Components</b>				F202	10-24 x 5/8 SHC Screw, GR5 SS		4
23	8670	Tilt-Up Hook	1	F206	#2 x 3/16 Drive Pin		2
24	5162-11	Roller Wheel (5" Poly) (Includes Item # F059)	2	F211	1/4-20 x 7/8 Hex Bolt		12
25	8490	Roller Wheel Axle Bolt	2	F246	1/4-20 x 1/2 PTHMS		2
26	NS	Deck Serial Number Plate	1	F278	3/8 Split Lock Washer		4***
27	5705-3	Blade, 22" (RH Rotation)	2	F295	3/16 x 1-1/2 Split Spring Pin		1
	5705-7	42 SD Blade Set with Hubs (Includes Items # 27, 28, F002 & F202)	*	F403	1/4-20 x 1/2 PTHMS, SS		2
28	5706	Blade Hub & Trash Guard	2	F464	1/4-20 x 7/8 PTH Bolt		9
29	7775-1	Hitch Pin, LH (Silver) #6	2	F517	Washer 3/8 x 1-1/8 x 1/8		4***
30	8735-10	Rubber Mat (5 x 6)	2	* Service Part Only			
31	8788-1	Rubber Mat (1 x 2)	1	** Item(s) used on the HD version of standard gearboxes. The HD cast iron gearboxes are interchangeable with Standard aluminum gearboxes.			
				*** Hardware used on HD gearbox configuration.			
				<b>NOTE:</b> Order Item # 4 to use the splined deck PTO shaft with Model T23, T25i, T30i, D21d, C19 and B19.			
				<b>NOTE:</b> Order Item # 5 to use the splined deck PTO shaft with Model S14 and B18.			

# DS42 DECK ASSEMBLY

## INCL. OPTIONAL HD GEARBOXES

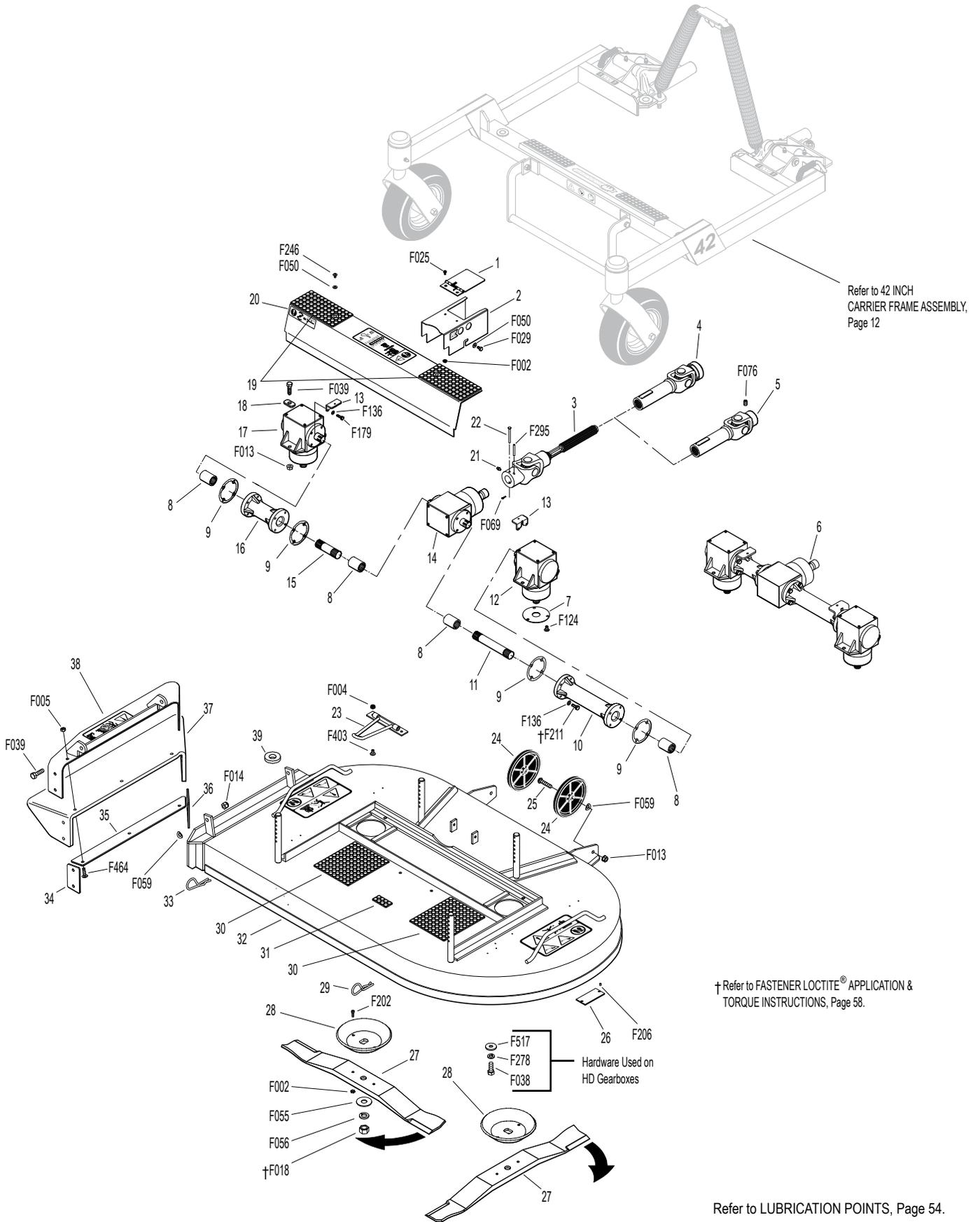

# 42 INCH BELT DRIVE COMPLETE CARRIER FRAME ASSEMBLY

ITEM NO.	PART NO.	DESCRIPTION	NO. REQ'D	ITEM NO.	PART NO.	DESCRIPTION	NO. REQ'D
<b>Spring and Pivot Mount Components</b>				<b>Fasteners</b>			
1	5975-3	Cable Tie (50# x 7")	4	F004		1/4-20 Keps Nut	4
2	5744-1	Spring Clip Bracket	1	F009		5/16-18 Whiz Locknut	1
3	5743-1	Spring Cover	2	F012		3/8-16 Keps Nut	2
4	5743-4	Eyebolt (3/8-16 x 2-3/4)	2	F047		3/8-16 x 4-1/2 Hex Bolt	2
5	5830	Grease Fitting	8	F055		5/8 SAE Washer	2
6	8667-29	Pivot Mount Adj., LH	1	F068		1/8 x 1 Cotter Pin	2
	8667-3	Pivot Mount Assembly, LH/Adj. (Includes Items # 5, 6, F353, F489 & F520)	*	F098		5/8-18 Slotted Hex Nut	2
7	8667-28	Pivot Mount Adj., RH	1	F117		Retainer Ring	2
	8667-4	Pivot Mount Assembly, RH/Adj. (Includes Items # 5, 7, F353, F489 & F520)	*	F123		1" External Snap Ring	4
8	5743-8	Extension Spring (1-1/2 x 7-3/4) (Includes Items # 1, F117 & F166)	2	F166		Retainer Ring	2
				F241		.375 x .875 x .10 Washer	2
				F316		5/16-18 x 1-3/4 Hex Bolt	1
				F317		3/16 x 1 Split Spring Pin	2
				F335		3/8-16 x 7/8 Set Screw, SS	2
				F336		3/8-16 Jam Nut	2
				F353		3/8-16 ESNA LP Nut	2
				F398		1/4-20 x 2 Hex Bolt	2
				F403		1/4-20 x 1/2 PTHMS, SS	2
				F489		Washer 1/4 x 7/8 x .090	2
				F520		1/4-28 x 3/8 Hex Bolt	2
<b>Carrier Frame Components</b>				* Service Part Only			
9	5747-9	Rubber Mat (1.5 x 8.5)	2	** May be ordered as a kit for dealer installation. Contact your Walker dealer.			
10	8662-2	Footrest, RH (Includes Items # 9 & 11)	1				
11	8662-4	Rectangular Plug (1 x 2)	2				
12	8674-11	Lever, Deck Lock, LH	1				
13	7406-1	Handle Grip (Red)	2				
14	8662-3	Footrest, LH (Includes Items # 9 & 11)	1				
15	8670	Tilt-Up Hook	1				
16	5850-5	Handle Grip (1 x 1 x 3-3/4)	1				
17	6811-1	Tilt Bar With Grip (15") (Includes Item # 16)	1				
18	7775-5	Lock Pin (5/16 x 1-5/8)	1				
19	5740-2	Deck Pin Bushing (5/8)	4				
20	5700-13	42BD Carrier Frame (Tapered Bearings)	1				
	5700-14	42BD Carrier Frame W/Forks (Tapered Bearings)	*				
21	8674-10	Lever, Deck Lock, RH	1				
<b>Caster Wheel Components</b>							
22	5714-7	Bearing Cap	4				
23	5714-5	Bearing, Caster Wheel	2				
24	5830-3	Grease Fitting (45 Degree)	2				
25	5715-4	Caster Wheel, Pneumatic (8 x 3.00-4) (Includes Items # 22-24)	2				
	5715-10	Tire, Pneumatic (8 x 3.00-4)	*				
	5715-9	Tire Tube, Pneumatic (2.80/2.50-4)	*				
	5715-3	Caster Wheel & Tire/No-Flat (8 x 3.00-4)	**				
	5715-11	Tire, Caster Wheel/No-Flat (8 x 3.00-4)	**				
26	5714-3	Axle Spacer Tube	2				
27	5770-1	Caster Wheel Fork	2				
28	8768-1	Seal (1-3/4 x 1-1/8)	2				
29	8037	Bearing Cone (3/4 ID)	4				
30	8769-1	Bearing Cup (1-3/4 x 1-7/16)	4				
31	8769-9	Dust Cap, Deck Caster	2				

# 42 INCH BELT DRIVE COMPLETE CARRIER FRAME ASSEMBLY

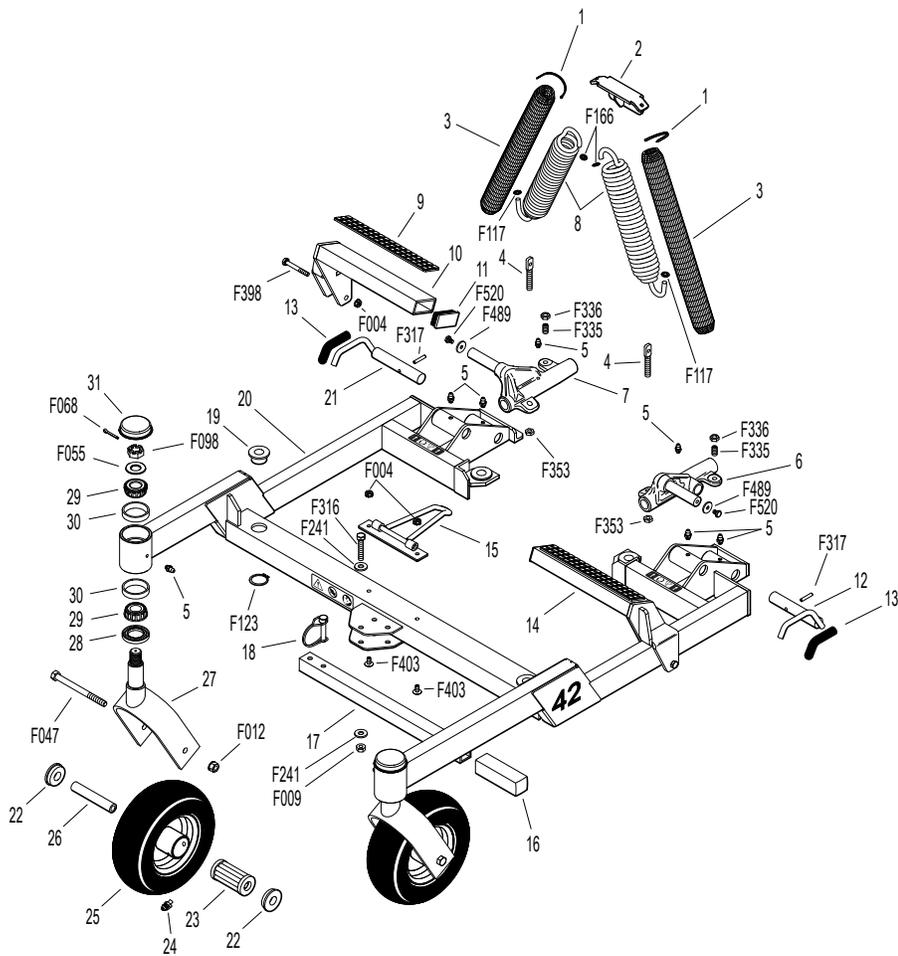

Refer to DS42 BELT  
DRIVE DECK ASSEMBLY,  
Page 18

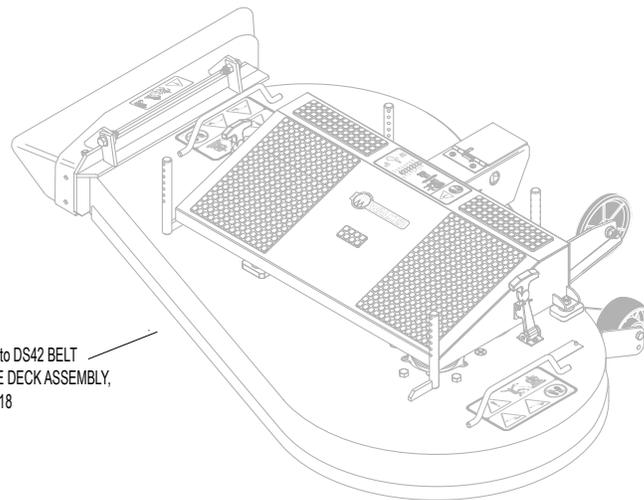

Refer to LUBRICATION POINTS, Page 56.

# DS42 BELT DRIVE DECK ASSEMBLY

ITEM NO.	PART NO.	DESCRIPTION	NO. REQ'D	ITEM NO.	PART NO.	DESCRIPTION	NO. REQ'D
<b>Deck Housing Components</b>				<b>Blade Spindle Components</b>			
1	2110	Hood Latch Assembly	2	45	8052-4	Blade Spindle	2
2	2786-3	Rubber Mat (2 x 7)	2	46	5830	Grease Fitting	2
3	8662-6	Footrest / 42BD (Includes Items # 2, 5 & 6)	1	47	7705-22	Blade 21.750 (RH Rotation)	2
4	4845	Rubber Bumper (1.0 x .625)	3	<b>Fasteners</b>			
5	2786-2	Rubber Mat (7 x 9-1/2)	2	F002	10-24 Keps Nut		10
6	8788-1	Rubber Mat (1 x 2)	1	F005	1/4-20 ESNA Nut		9
7	8490-1	Roller Wheel Axle Bolt	1	F009	5/16-18 Whiz Locknut		11
8	9772	Roller Wheel Assembly (2-1/2) (Includes Item # F059)	1	F012	3/8-16 Keps Nut		1
9	8490	Roller Wheel Axle Bolt	1	F013	3/8-16 Whiz Locknut		12
10	5162-10	Roller Wheel (5") (Includes Item # F059)	1	F014	3/8-16 ESNA Nut		2
11	6715-3	Roller Wheel Bearing	2	F025	10-24 x 3/8 PPHMS		10
12	6715-2	Roller Wheel	1	F029	1/4-20 x 1/2 Hex Bolt		2
13	6715-4	Axle Spacer Tube	1	F034	5/16-18 x 3/4 Hex Bolt		7
14	NS	Deck Serial Number Plate	1	F038	3/8-16 x 1 Hex Bolt		7
15	7775-1	Hitch Pin/LH Silver (#6)	2	F039	3/8-16 x 1-1/4 Hex Bolt		2
16	5707-4	42BD Deck Assembly	1	F041	3/8-16 x 1-3/4 Hex Bolt		1
17	7775-2	Hitch Pin/RH Gold (#6)	2	F048	1/2 SAE Washer		2
18	5709-12	Front Back Up Plate	1	F050	1/4 SAE Washer		2
19	5709-11	Center Backup Plate	1	F051	3/8 SAE Washer		1
20	5727-1	Washer Shim (5/8 ID)	4	F059	3/8 Wave Spring Washer		4
21	5709-13	Rear Back Up Plate	1	F067	3/16 x 3/16 x 1 Key		1
22	5709-8	Rubber Shield	1	F076	3/8-16 x 5/8 SQH Set Screw		*
23	5709-14	42SD Discharge Shield	1	F123	1" External Snap Ring		4
<b>Blade Drive Components</b>				F206	#2 x 3/16 Drive Pin		2
24	8618-1	Cover, PTO Shaft Guard	1	F262	3/8-16 x 4 Hex Bolt All Thread		1
25	8619-5	PTO Shaft Guard, 42BD	1	F265	1/2-20 x 1-1/2 Hex Bolt		2
26	5270	Bearing W/Collar (1")	1	F306	3/8-16 x 3/4 Hex Bolt		5
27	8726-1	PTO Bearing Housing	1	F318	3/8-16 x 3/4 SQH Set Screw		2
28	8726-2	PTO Drive Shaft	1	F336	3/8-16 Jam Nut		1
29	5270-1	Pivot Bearing	1	F388	3/8-16 x 2-1/2 Hex Bolt		1
30	2245-6	Idler Pulley Shaft	2	F404	5/8-18 Jam Nut		2
31	5285-4	U-Joint Shaft / 13-3/8	1	F445	1-7/8 Internal Snap Ring		1
32	7275-16	U-Joint Tube Assy, Spline	1	F458	Washer 1-1/4 x 5/8 x 3/16		2
33	5275-15	U-Joint Tube Assy (9.5" OAL), Spline (Includes Item # F076)	1	F464	1/4-20 x 7/8 PTH Bolt		9
34	8724-14	Idler Mount Weldment	1	F478	5/16-18 x 3-1/4 Hex Bolt		1
35	5195-2	Compression Spring (1 x 6-3/8) (Black)	2	F500	3/16 x 3/16 x 9/16 Key		3
36	2724-17	Guide Rod Bushing	4	F501	3/8-16 x 1 FHA Screw, SS		3
37	8724-15	Mount Base	1	* Service Part Only			
38	2724-16	Guide Rods	2	<b>NOTE:</b> Order Item # 32 to use the splined deck PTO shaft with Model T23, T25i, T30i, D21d, C19, B19 and B23i.			
39	5841	Retainer Washer (3/8 x 1-1/4)	3	<b>NOTE:</b> Order Item # 33 to use the splined deck PTO shaft with Model S14 and B18.			
40	7245-2	Idler Pulley	1				
41	6240-4	Drive Pulley, Micro V (3")	3				
42	8731-1	Blade Drive Belt (780L4-K)	1				
43	2265	Bearing (20mm)	1				
44	2245-2	Idler Pulley	1				

# DS42 BELT DRIVE DECK ASSEMBLY

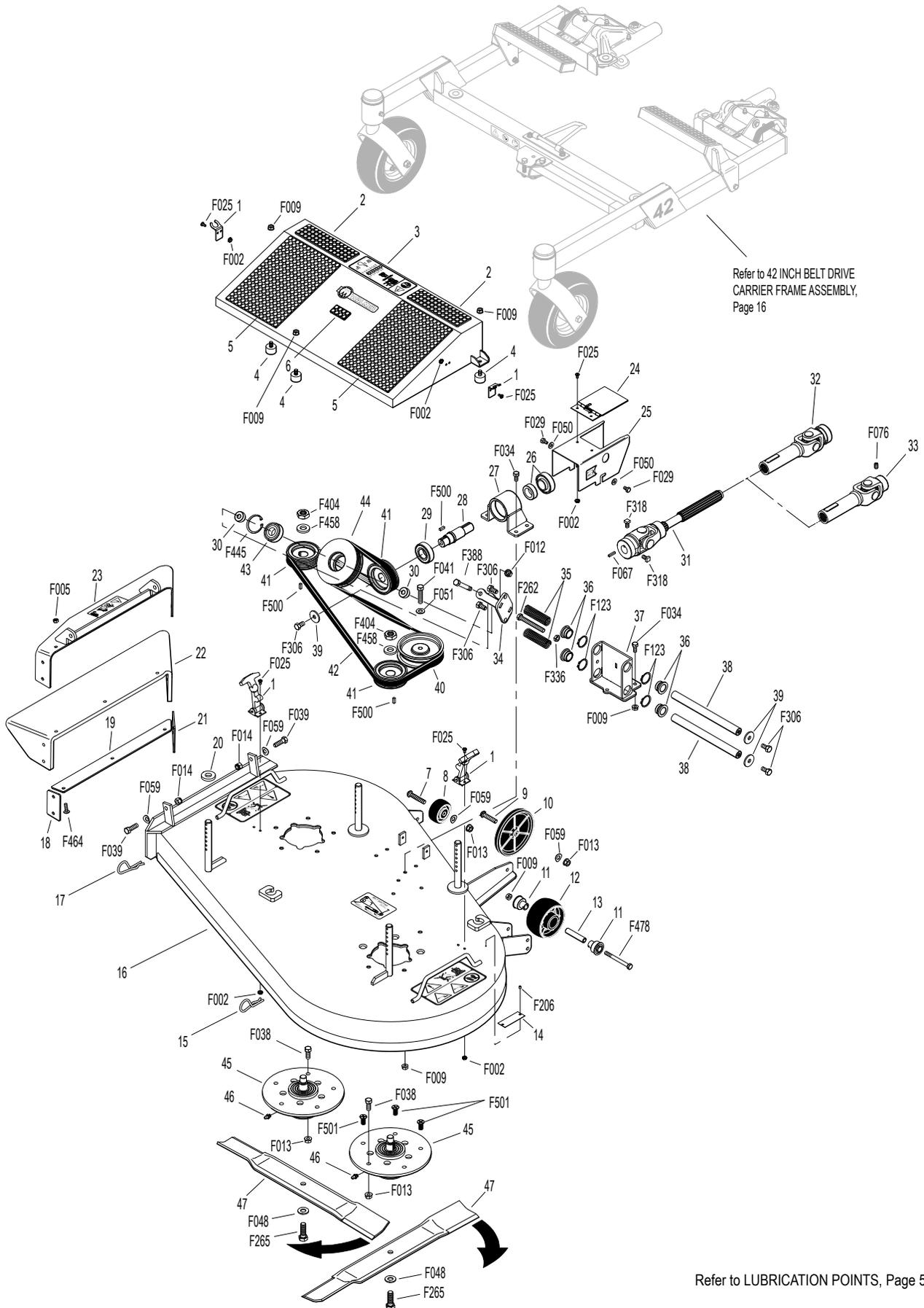

Refer to 42 INCH BELT DRIVE  
CARRIER FRAME ASSEMBLY,  
Page 16

Refer to LUBRICATION POINTS, Page 56.

# 48 INCH COMPLETE CARRIER FRAME ASSEMBLY

ITEM NO.	PART NO.	DESCRIPTION	NO. REQ'D	ITEM NO.	PART NO.	DESCRIPTION	NO. REQ'D
<b>Spring and Pivot Mount Components</b>				<b>Fasteners</b>			
1	5975-3	Cable Tie (50# x 7")	4	F012		3/8-16 Keps Nut	2
2	5744-1	Spring Clip Bracket	1	F020		5/16-18 ESNA Nut	2
3	5743-1	Spring Cover	2	F047		3/8-16 x 4-1/2 Hex Bolt	2
4	5743-4	Eyebolt (3/8-16 x 2-3/4)	2	F055		5/8 SAE Washer	2
5	5830	Grease Fitting	8	F068		1/8 x 1 Cotter Pin	2
6	8667-29	Pivot Mount Adj., LH	1	F084		5/16 Wave Spring Washer	2
	8667-3	Pivot Mount Assembly, LH/Adj. (Includes Items # 5, 6, F353, F489 & F520)	*	F098		5/8-18 Slotted Hex Nut	2
7	8667-28	Pivot Mount Adj., RH	1	F117		Retainer Ring	2
	8667-4	Pivot Mount Assembly, RH/Adj. (Includes Items # 5, 7, F353, F489 & F520)	*	F123		1" External Snap Ring	4
8	5743-8	Extension Spring (1-1/2 x 7-3/4) (Includes Items # 1, F117 & F166)	2	F166		Retainer Ring	2
				F226		5/16-18 x 7/8 Hex Bolt	2
				F317		3/16 x 1 Split Spring Pin	2
				F335		3/8-16 x 7/8 Set Screw, SS	2
				F336		3/8-16 Jam Nut	2
				F353		3/8-16 ESNA LP Nut	2
				F489		Washer 1/4 x 7/8 x .090	2
				F520		1/4-28 x 3/8 Hex Bolt	2
<b>Carrier Frame Components</b>				* Service Part Only			
9	8674-11	Lever, Deck Lock, LH	1	** May be ordered as a kit for dealer installation. Contact your Walker dealer.			
10	7406-1	Handle Grip (Red)	2				
11	8669	Lift Handle	1				
12	5748-10	Rubber Mat (1-1/2 x 6)	2				
13	5740-2	Deck Pin Bushing (5/8)	4				
14	8661-2	48" Carrier Frame (Less Pivots) (Includes Item # 12)	1				
	8661-1	48" Carrier Frame w/Forks (Less Pivots) (Includes Items # 12, 21-23, 25, F055, F068 & F098)	*				
15	8674-10	Lever, Deck Lock, RH	1				
<b>Caster Wheel Components</b>							
16	5714-7	Bearing Cap	4				
17	5714-5	Bearing, Caster Wheel	2				
18	5830-3	Grease Fitting (45 Degree)	2				
19	5715-4	Caster Wheel, Pneumatic (8 x 3.00-4) (Includes Items # 16-18)	2				
	5715-10	Tire, Pneumatic (8 x 3.00-4)	*				
	5715-9	Tire Tube, Pneumatic (2.80/2.50-4)	*				
	5715-3	Caster Wheel & Tire/No-Flat (8 x 3.00-4)	**				
	5715-11	Tire, Caster Wheel/No-Flat (8 x 3.00-4)	**				
20	5714-3	Axle Spacer Tube	2				
21	5770-1	Caster Wheel Fork	2				
22	8768-1	Seal (1-3/4 x 1-1/8)	2				
23	8037	Bearing Cone (3/4 ID)	4				
24	8769-1	Bearing Cup (1-3/4 x 1-7/16)	4				
25	8769-9	Dust Cap, Deck Caster	2				

# 48 INCH COMPLETE CARRIER FRAME ASSEMBLY

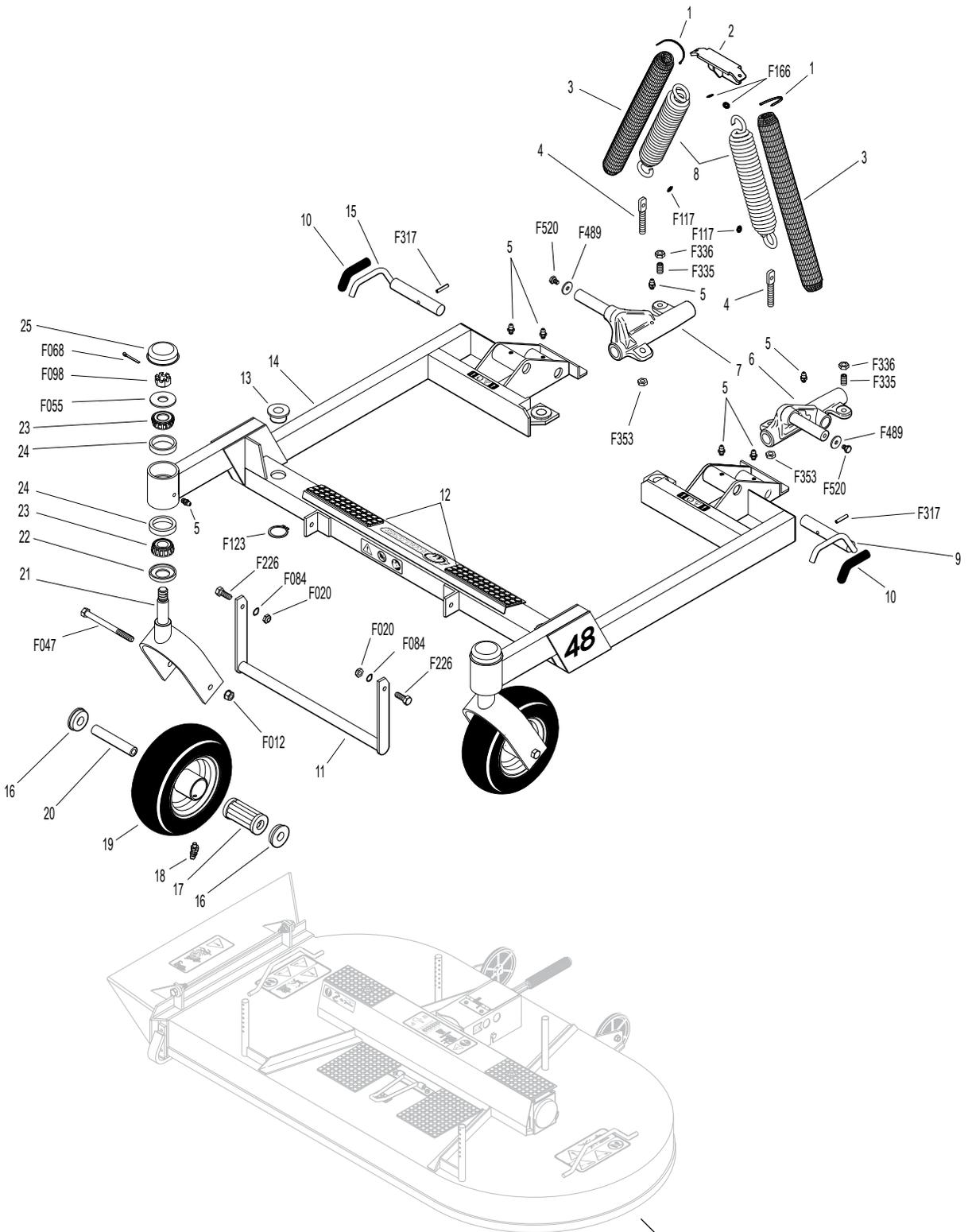

Refer to DS48  
DECK ASSEMBLY, Page 22

Refer to LUBRICATION POINTS, Page 54.

# DS48 DECK ASSEMBLY

## INCL. OPTIONAL HD GEARBOXES

ITEM NO.	PART NO.	DESCRIPTION	NO. REQ'D	ITEM NO.	PART NO.	DESCRIPTION	NO. REQ'D
<b>Gearbox and Drive Components</b>				30	8735-10	Rubber Mat (5 x 6)	2
1	8618-1	Cover, PTO Shaft Guard	1	31	8788-1	Rubber Mat (1 x 2)	1
2	8619	PTO Shaft Guard	1	32	7701-18	48 SD Deck Housing (Includes Items # 30, 31 & 34)	1
	8618	PTO Shaft Guard Assembly (Includes Items # 1, 2, F002 & F025)	*	33	7775-2	Hitch Pin, RH (Gold) #6	2
3	7285-15	U-Joint Shaft Assy, 90 Degree, Spline (Includes Items # 22, F069 & F295)	1	34	7707-10	48 SD Skid Bar	1
4	7275-16	U-Joint Tube Assy, Spline	1	35	6709-5	48 SD Discharge Shield	1
5	5275-15	U-Joint Tube (9.5" OAL), Spline (Includes Item # F076)	1	36	5727-1	Washer Shim (5/8 ID)	4
6	5704-60	Gearbox and Tube Assembly (Includes Items # 7-17, F124, F136, F179 & F211)	1	<b>Fasteners</b>			
	5704-61	HD Gearbox and Tube Assembly (Includes Items # 8-17, F136, F179 & F211)	**	F002	10-24 Keps Nut		6
7	5706-4	Seal Protector Plate	2	F004	1/4-20 Keps Nut		6
8	6054	Spline Coupling	4	F013	3/8-16 Whiz Locknut		6
9	P007	Gasket, Cap (Peerless #788030)	4	F014	3/8-16 ESNA Nut		2
10	5066	Gearbox Connector Tube (9-5/16)	1	F018	5/8-18 Hex Nut		2
11	6733-6	Connecting Shaft (7")	1	F025	10-24 x 3/8 PPHMS		2
12	5052-1	Gearbox (LH Rotation)	1	F029	1/4-20 x 1/2 Hex Bolt		2
	5052-5	HD Gearbox (LH Rotation)	**	F031	1/4-20 x 5/8 Hex Bolt		2
13	5704-1	Gearbox Cover Support	2	F038	3/8-16 x 1 Hex Bolt		4***
14	5051-16	Tee Gearbox, Shear	1	F039	3/8-16 x 1-1/4 Hex Bolt		6
	5051-6	HD Tee Gearbox, Shear	**	F050	1/4 SAE Washer		4
15	6733-2	Connecting Shaft (4-1/8)	1	F055	5/8 SAE Washer		2
16	5061	Gearbox Connector Tube (6-11/16)	1	F056	5/8 Split Lock Washer		2
17	5053-1	Gearbox (RH Rotation)	1	F059	3/8 Wave Spring Washer		4
	5053-5	HD Gearbox (RH Rotation)	**	F069	3/32 x 1/2 Cotter Pin		1
18	5052-3	1.375 x .750 x .187 Washer	4	F076	3/8-16 x 5/8 SQH Set Screw		*
19	5747-12	Rubber Mat (3 x 6)	2	F124	10-32 x 3/8 Tapitite Machine Screw		6
20	7785-3	48" Gearbox Cover (Includes Item # 19)	1	F136	AN960C416L Washer		16
21	5830	Grease Fitting	1	F179	1/4-20 x 1 Hex Bolt		4
22	8067-13	Shear Pin w/Cotter (Set of 5) (Includes Item # F069)	*	F202	10-24 x 5/8 SHC Screw, GR5 SS		4
				F206	#2 x 3/16 Drive Pin		2
				F211	1/4-20 x 7/8 Hex Bolt		14
				F246	1/4-20 x 1/2 PTHMS		2
				F278	3/8 Split Lock Washer		4***
				F295	3/16 x 1-1/2 Split Spring Pin		1
				F403	1/4-20 x 1/2 PTHMS, SS		2
				F517	Washer 3/8 x 1-1/8 x 1/8		4***
<b>Deck Housing Components</b>				* Service Part Only			
23	8670	Tilt-Up Hook	1	** Item(s) used on the HD version of standard gearboxes. The HD cast iron gearboxes are interchangeable with Standard aluminum gearboxes.			
24	5162-11	Roller Wheel (5" Poly) (Includes Item # F059)	2	*** Used on HD gearbox configuration.			
25	8490	Roller Wheel Axle Bolt	2	<b>NOTE:</b> Order Item # 4 to use the splined deck PTO shaft with Model T23, T25i, T30i, D21d, C19, B19 and B23i.			
26	NS	Deck Serial Number Plate	1	<b>NOTE:</b> Order Item # 5 to use the splined deck PTO shaft with Model B18.			
27	7705-1	Blade, 25" (RH Rotation)	2				
	7705-5	48 SD Blade Set with Hubs (Includes Items # 27, 28, F002 & F202)	*				
28	5706	Blade Hub & Trash Guard	2				
29	7775-1	Hitch Pin, LH (Silver) #6	2				



# 52 INCH COMPLETE CARRIER FRAME ASSEMBLY

ITEM NO.	PART NO.	DESCRIPTION	NO. REQ'D	ITEM NO.	PART NO.	DESCRIPTION	NO. REQ'D
<b>Spring and Pivot Mount Components</b>				<b>Caster Wheel Components</b>			
1	5975-3	Cable Tie (50# x 7")	4	17	8766	Axle Nut (3/4-16)	2
2	5744-1	Spring Clip Bracket	1	18	8768-2	Seal, Reverse Lip	4
3	5743-1	Spring Cover	2	19	8037	Bearing Cone (3/4 ID)	4
4	5743-4	Eyebolt (3/8-16 x 2-3/4)	2	20	8037-2	Bearing Race	4
5	5830	Grease Fitting	8	21	5830-3	Grease Fitting (45 Degree)	2
6	8667-29	Pivot Mount Adj., LH	1	22	8768	Caster Wheel, Pneumatic (11 x 4.00-5)	2
	8667-3	Pivot Mount Assembly, LH/Adj. (Includes Items # 5, 6, F353, F489 & F520)	*		8768-3	Tire, Pneumatic (11 x 4.00-5)	*
7	8667-28	Pivot Mount Adj., RH	1		8768-5	Caster Wheel (5 x 3)	*
	8667-4	Pivot Mount Assembly, RH/Adj. (Includes Items # 5, 7, F353, F489 & F520)	*	23	8767	Axle, Caster Wheel (5-1/8)	2
8	5743-6	Extension Spring (1-1/2 x 7-3/4) (Includes Items # 1, F117 & F166)	2	24	8765-11	Caster Wheel Fork	2
<b>Carrier Frame Components</b>				25	8769-7	Seal	2
9	8674-11	Lever, Deck Lock, LH	1	26	8769-6	Bearing Cone (1" ID)	4
10	7406-1	Handle Grip (Red)	2	27	8769-5	Bearing Cup (2 x 1-5/8)	4
11	8811-12	52 SD Carrier Frame	1	28	8769-8	Dust Cap, Deck Caster	2
	8811-10	52 SD Carrier Frame, with Pivots (Includes Items # 9, 10, 15, F317, F335 & F336)	*	<b>Fasteners</b>			
12	5850-5	Handle Grip (1 x 1 x 3-3/4)	1	F117	Retainer Ring		2
13	8811-25	Tilt Bar, with Grip (35") (Includes Item # 12)	1	F140	7/16-14 x 1 Hex Bolt		4
14	7775-5	Lock Pin (5/16 x 1-5/8)	1	F166	Retainer Ring		2
15	8674-10	Lever, Deck Lock, RH	1	F218	7/16 Split Lock Washer		4
16	8740	Deck Pin Bushing (3/4 ID)	4	F263	1-1/4 External Snap Ring		4
				F317	3/16 x 1 Split Spring Pin		2
				F335	3/8-16 x 7/8 Set Screw, SS		2
				F336	3/8-16 Jam Nut		2
				F344	3/4-16 Slotted Hex Nut		2
				F347	3/4 SAE Washer		2
				F348	1/8 x 1-1/2 Cotter Pin		2
				F353	3/8-16 ESNA LP Nut		2
				F489	Washer 1/4 x 7/8 x .090		2
				F520	1/4-28 x 3/8 Hex Bolt		2

\* Service Part Only

**NOTE:** The E-Z Pin Puller P/N 8770 can be ordered to assist removing and installing height adjustment hitch pins on larger decks. This item stows on tractor when not in use.



# DS52 DECK ASSEMBLY

ITEM NO.	PART NO.	DESCRIPTION	NO. REQ'D	ITEM NO.	PART NO.	DESCRIPTION	NO. REQ'D	
<b>Blade Drive Components</b>				42	8810-10	52 SD Deck Housing (Includes Items # 39 & 40)	1	
1	8789-5	Pulley Guard	1	43	8692-10	Baffle, DSD52	1	
2	8786-15	Footrest Assembly (Includes Item # 18)	1	44	8052-2	Blade Spindle	3	
3	8754-3	Edge Molding	2	45	5705-25	Blade Spacer	3	
4	8754-5	52 SD Cover Plate (Includes Items # 3 & F354)	1	46	5705-14	Blade, 18-1/2	3	
5	8245	Idler Pulley (6")	3		8738-7	52 SD Blade Set	*	
6	8755	Blade Drive Pulley (3-7/8)	3	47	8707	52/62 SD Skid Bar	1	
7	8762	Dampening Spring (Gas)	1	48	8709	52/62 SD Discharge Shield	1	
8	5146	10mm Ball Stud	2	49	5052-3	1.375 x .750 x .187 Washer	12	
9	8373-3	Idler Arm (2-Hole)	1	50	8670-10	Tilt-Up Hook	1	
10	5830	Grease Fitting	3	<b>Fasteners</b>				
11	8374-1	Idler Arm Guide	1		F004	1/4-20 Keps Nut	11	
12	7201-3	Fiberglide Bearing	2		F009	5/16-18 Whiz Locknut	7	
13	7201-4	Inner Race (1-1/2)	1		F012	3/8-16 Keps Nut	4	
14	5841	Retainer Washer (3/8 x 1-1/4)	1		F013	3/8-16 Whiz Locknut	14	
15	8736	Blade Drive Belt (R3VX1000-2)	1		F014	3/8-16 ESNA Nut	3	
16	6240-2	Drive Pulley (4-1/2 / 3V) (Includes Items # F114 & F277)	1		F020	5/16-18 ESNA Nut	2	
17	8787	Deck Cover Knob	3		F023	10-24 ESNA Nut	2	
18	8786-10	Rubber Mat (6 x 10-1/2)	2		F029	1/4-20 x 1/2 Hex Bolt	5	
<b>Gearbox and Dolly Wheel Components</b>						F032	1/4-20 x 3/4 Hex Bolt	2
19	6206-1	Air Vent Valve	1		F034	5/16-18 x 3/4 Hex Bolt	1	
20	8745-25	Dolly Wheel/PTO Guard Assembly (Includes Items # 21, 26, 28, 31, 34, 35, F012, F013, F046, F052, F168, F226, F339 & F355)	*		F039	3/8-16 x 1-1/4 Hex Bolt	2	
21	6715	Roller Wheel (3-7/8)	3		F040	3/8-16 x 1-1/2 Hex Bolt	12	
22	8810-30	Tilt Dolly Mount Frame	1		F041	3/8-16 x 1-3/4 Hex Bolt	3	
23	8810-34	Axle, Dolly Mount	1		F046	3/8-16 x 3-1/2 Hex Bolt	1	
24	8285-2	U-Joint Shaft Assy, T-Scope (Includes Items # 25, F076 & F277)	1		F048	1/2 SAE Washer	3	
25	5830-3	Grease Fitting (45 Degree)	2		F051	3/8 SAE Washer	9	
26	8788	Rubber Bumper (Self-Adhesive Mount)	1		F052	5/16 External Star Lock Washer	2	
27	8745-14	Retract Lever	1		F059	3/8 Wave Spring Washer	2	
28	5850-3	Handle Grip, Foam (3-1/4)	1		F068	1/8 x 1 Cotter Pin	2	
29	8745-12	Actuator Link	1		F076	3/8-16 x 5/8 SQH Set Screw	*	
30	8745-13	Dolly Wheel Mount (Includes Item # 10)	1		F108	3/8-16 x 2 Hex Bolt	1	
31	8745-15	Axle Spacer Tube	1		F114	5/16-18 x 5/8 SQH Set Screw	2	
32	5229	Extension Spring (1/2 x 2-1/4)	1		F134	AN960816L Washer	3	
33	8745-20	Mount Bracket (Includes Items # 26, F052, F068 & F339)	1		F168	5/16 Split Lock Washer	8	
34	5103-4	Pivot Bushing (3/8 ID)	2		F206	#2 x 3/16 Drive Pin	2	
35	8745-40	PTO Cover Plate	1		F226	5/16-18 x 7/8 Hex Bolt	12	
36	8051-11	Right Angle Gearbox (Includes Item # 19)	1		F241	.375 x .875 x .10 Washer	2	
<b>Deck Housing Components</b>						F246	1/4-20 x 1/2 PTHMS	2
37	8727	Washer Shim (13/16 x 1/4)	4		F252	10-24 x 3/4 PFHMS	2	
38	8775	Hitch Pin (#219)	4		F276	5/8-11 Jam Nut	3	
39	8735-10	Rubber Mat (5 x 6)	2		F277	3/16 x 5/8 Woodruff Key (#605)	5	
40	8790	Rubber Cushion Strip	3		F295	3/16 x 1-1/2 Split Spring Pin	2	
41	NS	Deck Serial Number Plate	1		F339	5/16-18 x 3/4 Self-Tapping Bolt	2	
					F343	1/2-20 x 2 Hex Bolt	3	
					F354	5/16 Knurled Thread Insert	2	
					F355	3/8-16 x 4 Hex Bolt	1	
					F356	1/4-20 x 5/8 PTHMS, SS	2	
					F458	Washer 1-1/4 x 5/8 x 3/16	3	
				*	Service Part Only			



# DS52 MULCHING KIT

ITEM NO.	PART NO.	DESCRIPTION	NO. REQ'D
----------	----------	-------------	-----------

**Kit 8691 Mulching Kit (For DS52 Deck Assembly)**  
 Includes Items # 1-7, fasteners listed and instructions. May be ordered as a factory-installed option or as a kit for dealer installation. Contact your Walker dealer. Refer also to **DS52 DECK ASSEMBLY**, page 26.

1	8691-4	Baffle, RH	1
2	8691-3	Baffle, Center	1
3	8691-2	Baffle, LH	1
4	8052-9	Mulch Blade Spacer	3
5	5705-15	Blade, 18-3/8" Upper Mulch	3
	8738-8	52 SD Mulching Blade Set	*
6	8691-10	Blade Saddle	3
7	5705-14	Blade, 18-1/2 (RH Rotation)	3

ITEM NO.	PART NO.	DESCRIPTION	NO. REQ'D
----------	----------	-------------	-----------

## Fasteners

F004		1/4-20 Keps Nut	9
F029		1/4-20 x 1/2 Hex Bolt	9
F048		1/2 SAE Washer	3
F343		1/2-20 x 2 Hex Bolt	3

\* Service Part Only. Includes 5705-15 Blades (3 Pieces).

**NOTE:** Reuse Item # 7 from **DS52 DECK ASSEMBLY**. Refer to **DS52 DECK ASSEMBLY**, page 26.

# DS52 MULCHING KIT

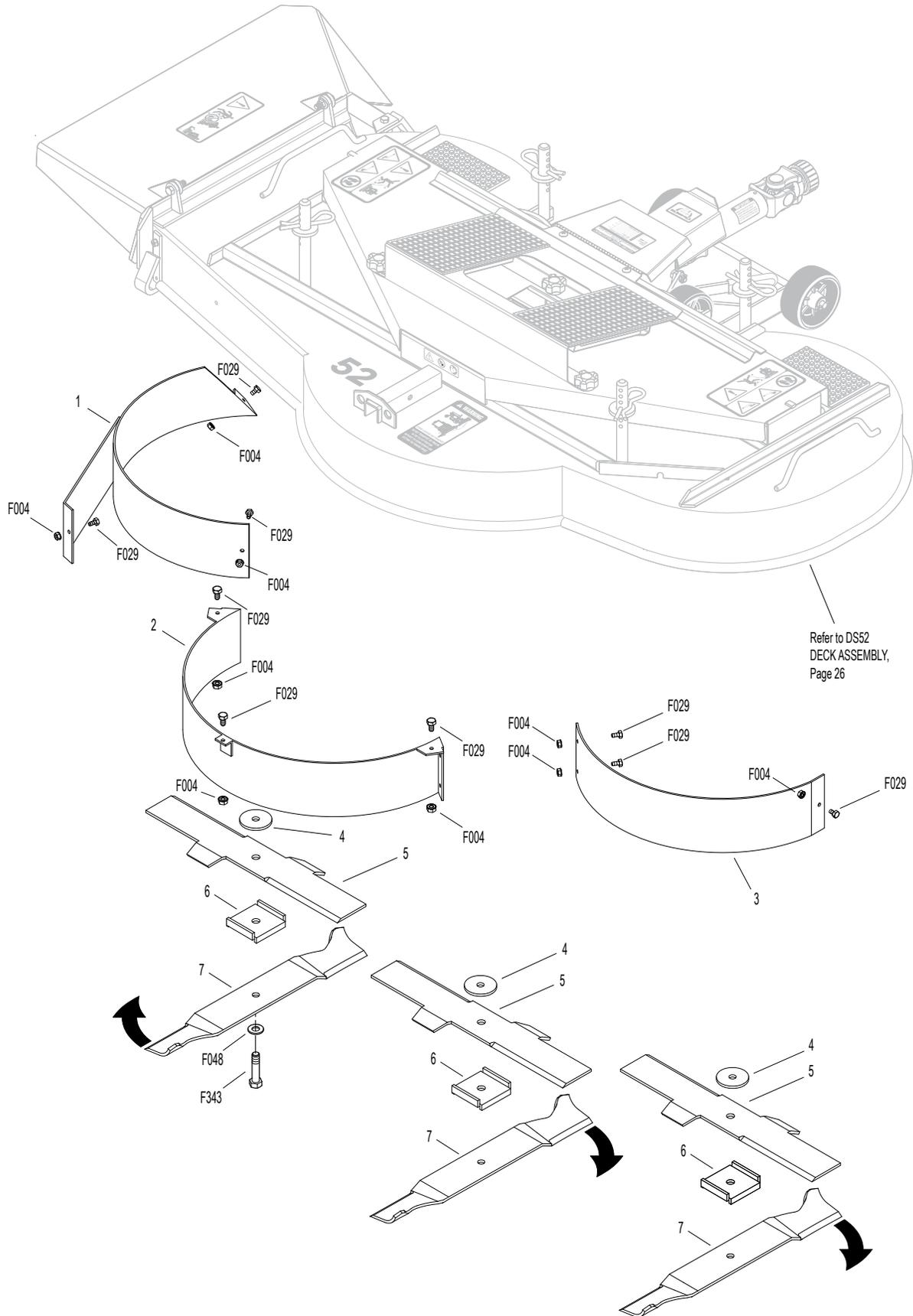

# 52 INCH COMPLETE CARRIER FRAME ASSEMBLY

ITEM NO.	PART NO.	DESCRIPTION	NO. REQ'D	ITEM NO.	PART NO.	DESCRIPTION	NO. REQ'D
<b>Spring and Pivot Mount Components</b>				37	2214-10	Rod End, Female (3/8-24)	4
1	2744-1	Spring Clip Bracket	1	38	2722-4	Pivot Shaft	2
2	5975-3	Cable Tie (50# x 7")	4	39	2655	Lift Chain	4
3	5743-1	Spring Cover	2	40	4407-4	Bow Tie Cotter Pin	2
4	5743-6	Extension Spring (1-1/2 x 7-3/4) (Includes Items # 2, F117 & F166)	2	41	2215-4	Height Adjustment Rod	2
5	5743-3	Eyebolt (3/8-16 x 2)	2	42	5146-1	10mm Ball Stud x 5/8	2
6	2723	Counter Weight Spring Mount	2	43	5146	10mm Ball Stud	2
7	2723-5	Locking Arm, LH (Includes Item # F432)	1	44	2215	Gas Spring Assembly	2
8	5830	Grease Fitting	10	45	2721-3	Lifting Arm (Includes Item # 8)	1
9	2667-1	Pivot Mount, LH (Includes Item # 8)	1	46	2721-2	Lifting Cross Tube	1
10	2723-4	Pivot Shaft	2	47	2723-7	Height Adjustment Arm (Includes Item # 48)	1
11	2667-2	Pivot Mount, RH (Includes Item # 8)	1	48	5850-3	Handle Grip, Foam (3-1/4)	1
12	2723-6	Locking Arm, RH (Includes Item # F432)	1	49	2722-7	Foot Pedal Pad	1
				50	2722-6	Deck Height Adjustment Trigger (Includes Item # 8)	1
<b>Carrier Frame Components</b>				<b>Fasteners</b>			
13	2215-2	Gas Spring Cover, RH	1	F004	1/4-20 Keps Nut		6
14	2723-2	Outer Height Adjustment Plate	1	F009	5/16-18 Whiz Locknut		13
15	7775-9	Wire Lock Pin (5/16 x 1-3/8)	1	F013	3/8-16 Whiz Locknut		14
16	2720-3	Height Adjustment Spacer	4	F014	3/8-16 ESNA Nut		2
17	2723-1	Inner Height Adjustment Plate	1	F035	5/16-18 x 1-1/4 Hex Bolt		2
18	2215-3	Gas Spring Cover, LH	1	F038	3/8-16 x 1 Hex Bolt		2
19	8740	Deck Pin Bushing (3/4 ID)	4	F039	3/8-16 x 1-1/4 Hex Bolt		2
20	2911-5	DRD52 Carrier Frame	1	F040	3/8-16 x 1-1/2 Hex Bolt		5
21	7775-5	Lock Pin (5/16 x 1-5/8)	1	F048	1/2 SAE Washer		2
22	8811-25	Tilt Bar W/Grip (35") (Includes Item # 23)	1	F050	1/4 SAE Washer		6
23	5850-5	Handle Grip (1 x 1 x 3-3/4)	1	F071	3/4 External Snap Ring		2
<b>Caster Wheel Components</b>				F090	1/4-20 x 2-1/2 Hex Bolt		4
24	8769-8	Dust Cap, Deck Caster	2	F117	Retainer Ring		2
25	8769-6	Bearing Cone (1" ID)	4	F132	1/4-20 x 2-3/4 Hex Bolt		2
26	8769-5	Bearing Cup (2 x 1-5/8)	4	F166	Retainer Ring		2
27	8769-7	Seal	2	F205	5/16-18 x 1/4 Set Screw (Knurl Point)		2
28	2770	Caster Wheel Fork	2	F215	3/8-16 x 1/2 x 1/2 S Bolt		2
29	7038	Tail Wheel Axle (3/4 x 5-9/16)	2	F218	7/16 Split Lock Washer		4
30	8037-1	Seal, Outer (1-3/4 x 1-1/8)	2	F219	7/16-14 x 1-1/4 Hex Bolt		4
31	8037	Bearing Cone (3/4 ID)	4	F226	5/16-18 x 7/8 Hex Bolt		5
32	8035	Tail Wheel & Tire (13 x 5.00-6) (W/Bearing Race)	2	F241	.375 x .875 x .10 Washer		18
33	8768-2	Seal, Reverse Lip	2	F263	1-1/4 External Snap Ring		6
34	8038-1	Spacer, Tail Wheel Axle (.750 x ID x 1.125 OD)	2	F268	5/16-18 x 3 Hex Bolt		1
35	8039	Nut, Tail Wheel Axle	2	F298	3/8-24 Jam Nut		4
<b>Deck Lift Components</b>				F344	3/4-16 Slotted Hex Nut		2
36	2722-5	Deck Height Adjustment, LH (Includes Item # 8)	1	F347	3/4 SAE Washer		2
				F348	1/8 x 1-1/2 Cotter Pin		2
				F378	3/8-16 x 6 Hex Bolt		1
				F432	3/16 x 1/2 Split Spring Pin		2
				F436	3/16 x 1-1/8 Spring Pin		4
				F437	Clevis Pin (1/4 x 1)		2
				F438	5/16-18 x 2-3/4 Hex Bolt		1



# DR52 DECK ASSEMBLY

ITEM NO.	PART NO.	DESCRIPTION	NO. REQ'D	ITEM NO.	PART NO.	DESCRIPTION	NO. REQ'D
<b>Deck Housing Components</b>				<b>Blade Spindle Components</b>			
1	2786-5	Footrest, DRD52 (Includes Items # 2 & 3)	1	41	2052-1	Blade Spindle	3
2	2786-3	Rubber Mat (2 x 7)	2	42	5830	Grease Fitting	3
3	2786-2	Rubber Mat (7 x 9-1/2)	2	43	7705-14	Blade (18.333)	3
4	2786-4	Locking Finger	2	<b>Fasteners</b>			
5	2110	Hood Latch Assembly	2	F002	10-24 Keps Nut		12
6	2703-5	Knob, 10-24 x 1/2	4	F004	1/4-20 Keps Nut		6
7	2724-9	Spindle Cover	2	F009	5/16-18 Whiz Locknut		16
8	4845	Rubber Bumper (1.0 x .625)	4	F012	3/8-16 Keps Nut		1
9	9772	Roller Wheel Assembly (2-1/2) (Includes Item # F059)	2	F013	3/8-16 Whiz Locknut		23
10	8490-1	Roller Wheel Axle Bolt	2	F025	10-24 x 3/8 PPHMS		10
11	NS	Deck Serial Number Plate	1	F028	10-24 x 3/4 PPHMS		2
12	8735-10	Rubber Mat (5 x 6)	2	F029	1/4-20 x 1/2 Hex Bolt		4
13	2910-3	DRD52 Deck Housing (Includes Item # 12)	1	F031	1/4-20 x 5/8 Hex Bolt		4
14	2720-5	Deck Height Adjustment Clevis	2	F034	5/16-18 x 3/4 Hex Bolt		2
15	6715-3	Roller Wheel Bearing	8	F039	3/8-16 x 1-1/4 Hex Bolt		16
16	6715-4	Axle Spacer Tube	4	F041	3/8-16 x 1-3/4 Hex Bolt		3
17	6715-2	Roller Wheel	4	F048	1/2 SAE Washer		3
18	8670-12	Tilt-Up Hook	1	F050	1/4 SAE Washer		2
<b>Blade Drive Components</b>				F051	3/8 SAE Washer		3
19	2618-1	Cover, PTO Shaft Guard	1	F059	3/8 Wave Spring Washer		2
20	2620-3	Rubber Flap	1	F065	3/16 x 3/4 Woodruff Key (#606)		3
21	2620-2	Backing Plate	1	F067	3/16 x 3/16 x 1 Key		1
22	2619-2	PTO Shaft Guard	1	F075	5/16-18 x 1/2 SQH Set Screw		2
	2618-3	PTO Shaft Guard Assembly (Includes Items # 19-22, F002, F025 & F028)	*	F123	1" External Snap Ring		4
23	5270	Bearing W/Collar (1")	2	F206	#2 x 3/16 Drive Pin		2
24	2726	PTO Bearing Housing	1	F226	5/16-18 x 7/8 Hex Bolt		4
25	2726-1	PTO Drive Shaft	1	F262	3/8-16 x 4 Hex Bolt All Thread		1
26	2240-4	Drive Pulley (Includes Items # F075 & F435)	1	F265	1/2-20 x 1-1/2 Hex Bolt		3
27	2245-6	Idler Pulley Shaft	2	F306	3/8-16 x 3/4 Hex Bolt		4
28	4245-1	Idler Pulley (4/Flat)	1	F318	3/8-16 x 3/4 SQH Set Screw		2
29	8285-4	U-Joint Shaft Assembly, Spline (Includes Item # F318)	1	F336	3/8-16 Jam Nut		1
30	2724-14	Idler Mount Weldment	1	F388	3/8-16 x 2-1/2 Hex Bolt		1
31	5195-2	Compression Spring (1 x 6-3/8) (Black)	2	F404	5/8-18 Jam Nut		3
32	2724-17	Guide Rod Bushing	4	F405	3/8-16 x 1-1/2 FHA Screw, SS		2
33	2724-18	Mount Base	1	F408	7/16-20 Jam Nut		2
34	2724-16	Guide Rods	2	F435	1/4 x 1/4 x 1-1/4 Key		1
35	5841	Retainer Washer (3/8 x 1-1/4)	2	F445	1-7/8 Internal Snap Ring		1
36	2240-6	Blade Drive Pulley (3-1/8) W/Shield	3	F458	Washer 1-1/4 x 5/8 x 3/16		3
37	8245	Idler Pulley (6")	2	F478	5/16-18 x 3-1/4 Hex Bolt		4
38	2731-2	Blade Drive Belt (1150L4-K)	1	* Service Part Only			
39	2265	Bearing (20mm)	1				
40	2245-2	Idler Pulley	1				

# DR52 DECK ASSEMBLY

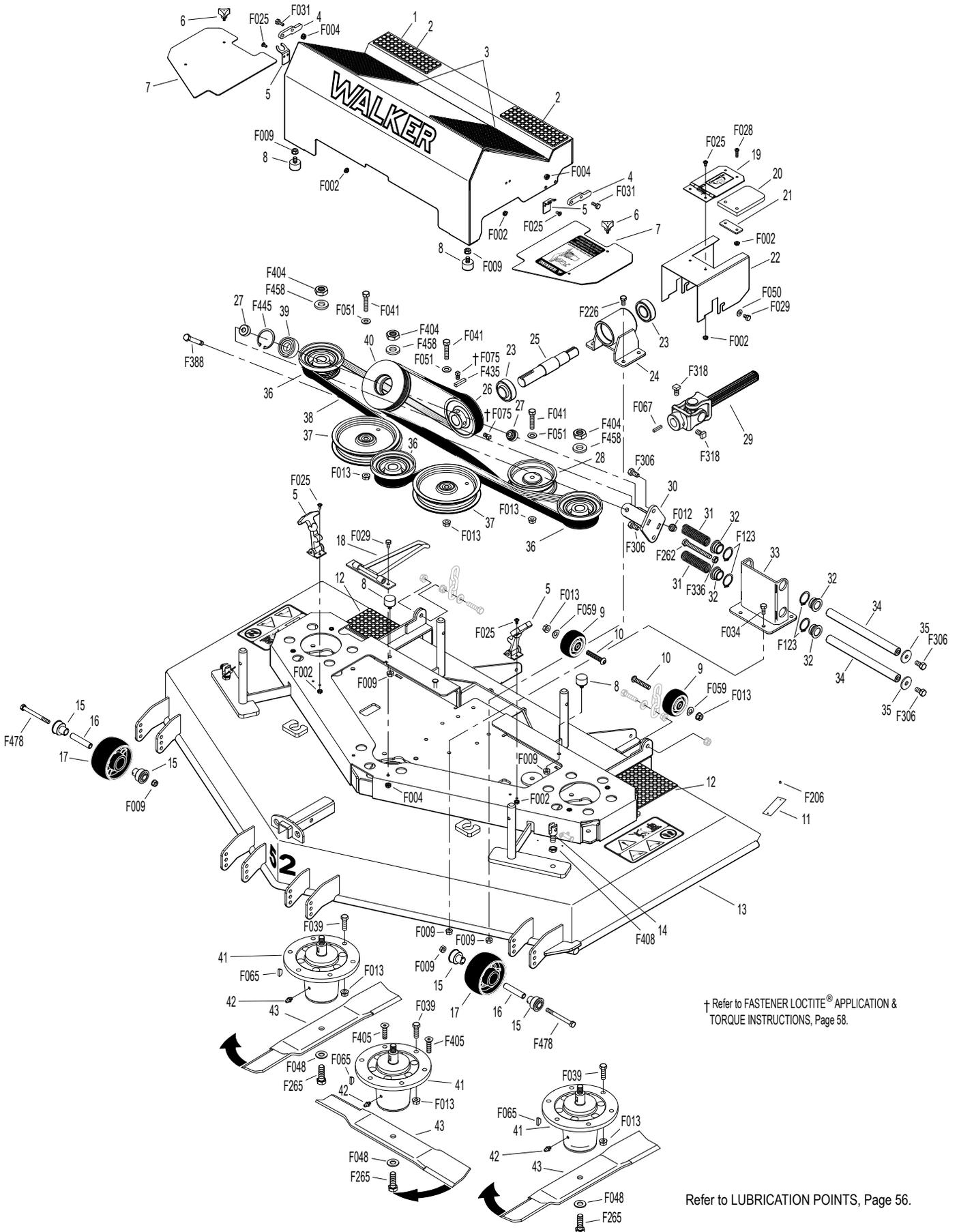

† Refer to FASTENER LOCTITE® APPLICATION & TORQUE INSTRUCTIONS, Page 58.

Refer to LUBRICATION POINTS, Page 56.

# 56 INCH COMPLETE CARRIER FRAME ASSEMBLY

ITEM NO.	PART NO.	DESCRIPTION	NO. REQ'D	ITEM NO.	PART NO.	DESCRIPTION	NO. REQ'D
<b>Spring and Pivot Mount Components</b>				<b>Caster Wheel Components</b>			
1	5975-3	Cable Tie (50# x 7")	4	18	5714-7	Bearing Cap	4
2	5744-1	Spring Clip Bracket	1	19	5714-5	Bearing, Caster Wheel	2
3	5743-1	Spring Cover	2	20	5830-3	Grease Fitting (45 Degree)	2
4	5743-3	Eyebolt (3/8-16 x 2)	2	21	5715-4	Caster Wheel, Pneumatic (8 x 3.00-4)	2
5	5830	Grease Fitting	8			(Includes Items # 18-20)	
6	8667-29	Pivot Mount Adj., LH	1		5715-10	Tire, Pneumatic (8 x 3.00-4)	*
	8667-3	Pivot Mount Assembly, LH/Adj. (Includes Items # 5, 6, F014, F489 & F520)	*		5715-9	Tire Tube, Pneumatic (2.80/2.50-4)	*
7	8667-28	Pivot Mount Adj., RH	1		5715-3	Caster Wheel & Tire/No-Flat (8 x 3.00-4)	**
	8667-4	Pivot Mount Assembly, RH/Adj. (Includes Items # 5, 7, F014, F489 & F520)	*		5715-11	Tire, Caster Wheel/No-Flat (8 x 3.00-4)	**
8	5743-6	Extension Spring (1-1/2 x 7-3/4) (Includes Items # 1, F117 & F166)	2	22	5714-3	Axle Spacer Tube	2
				23	5770-1	Caster Wheel Fork	2
				24	8768-1	Seal (1-3/4 x 1-1/8)	2
				25	8037	Bearing Cone (3/4 ID)	4
				26	8769-1	Bearing Cup (1-3/4 x 1-7/16)	4
				27	8769-9	Dust Cap, Deck Caster	2
<b>Carrier Frame Components</b>				<b>Fasteners</b>			
9	8674-11	Lever, Deck Lock, LH	1		F012	3/8-16 Keps Nut	2
10	7406-1	Handle Grip, Red	2		F014	3/8-16 ESNA Nut	2
11	5748-10	Rubber Mat (1-1/2 x 6)	2		F047	3/8-16 x 4-1/2 Hex Bolt	2
12	6720-1	56 SD Carrier Frame (Includes Item # 11)	1		F055	5/8 SAE Washer	2
13	5740-2	Deck Pin Bushing (5/8)	4		F068	1/8 x 1 Cotter Pin	2
14	8674-10	Lever, Deck Lock, RH	1		F098	5/8-18 Slotted Hex Nut	2
15	5850-5	Handle Grip (1 x 1 x 3-3/4)	1		F117	Retainer Ring	2
16	6811-25	Tilt Bar With Grip (30") (Includes Item # 15)	1		F123	1" External Snap Ring	4
17	7775-5	Lock Pin (5/16 x 1-5/8)	1		F166	Retainer Ring	2
					F317	3/16 x 1 Split Spring Pin	2
					F335	3/8-16 x 7/8 Set Screw, SS	2
					F336	3/8-16 Jam Nut	2
					F489	Washer 1/4 x 7/8 x .090	2
					F520	1/4-28 x 3/8 Hex Bolt	2

\* Service Part Only

\*\* May be ordered as a kit for dealer installation. Contact your Walker Dealer.

**NOTE:** When installing Item # 8 on decks prior to S/N DX-62875, the swivel hook end should be attached to the deck carrier frame.

# 56 INCH COMPLETE CARRIER FRAME ASSEMBLY

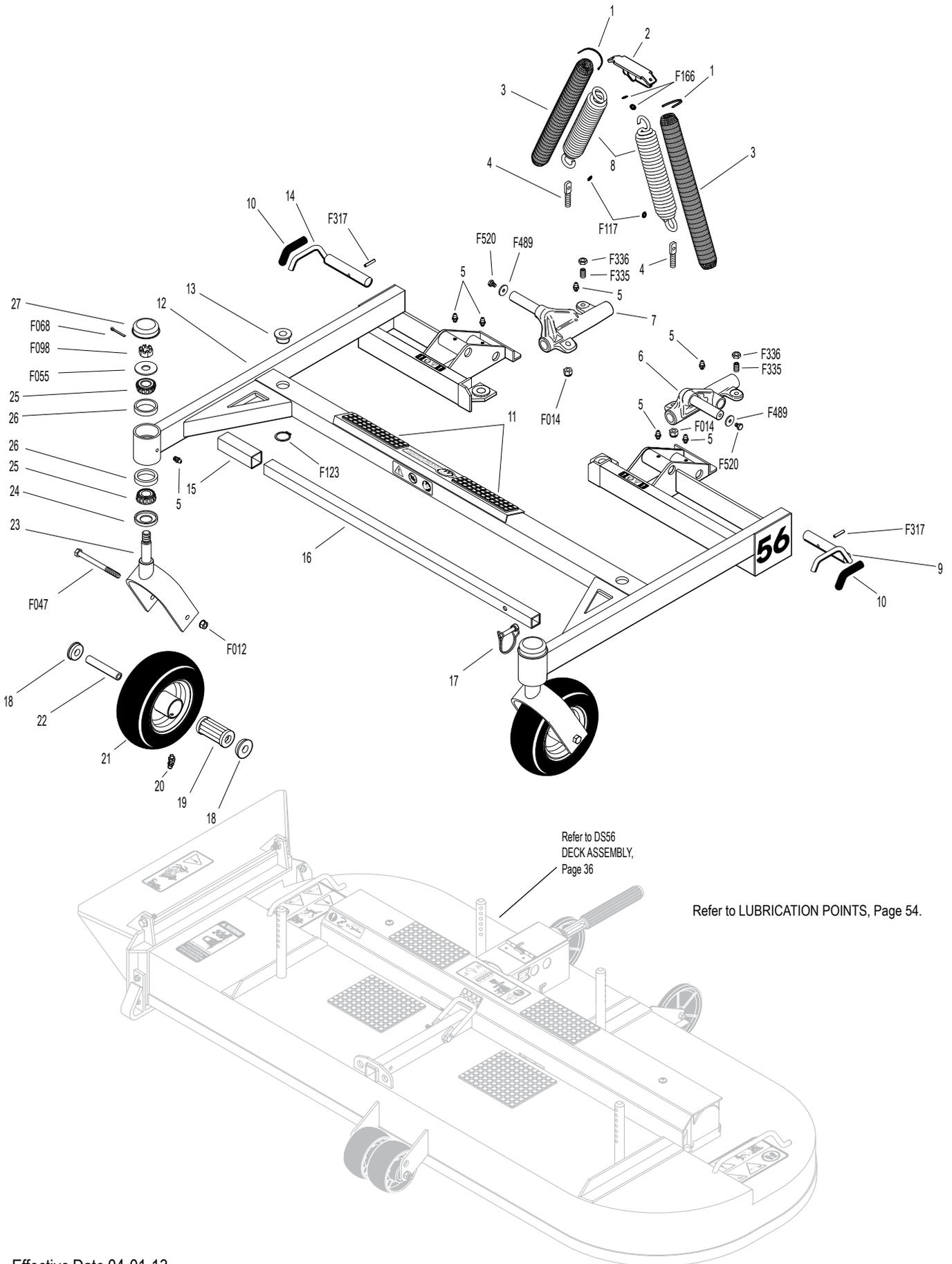

Effective Date 04-01-13  
Use only genuine Walker® replacement parts.

# DS56 DECK ASSEMBLY

ITEM NO.	PART NO.	DESCRIPTION	NO. REQ'D	ITEM NO.	PART NO.	DESCRIPTION	NO. REQ'D
<b>Gearbox and Drive Components</b>				32	8735-10	Rubber Mat (5 x 6)	2
1	8618-1	Cover, PTO Shaft Guard	1	33	6715-4	Axle Spacer Tube	2
2	8619-2	PTO Shaft Guard	1	34	6715-2	Roller Wheel	2
	8618-3	PTO Shaft Guard Assembly (Includes Items # 1, 2, F002 & F025)	*	35	6720-10	56 SD Deck Housing (Includes Items # 19 & 32)	1
3	7275-16	U-Joint Tube Assy, Spline	1	36	7775-2	Hitch Pin, RH (Gold) #6	2
4	5275-15	U-Joint Tube Assy (9.5" OAL), Spline (Includes Item # F076)	1	37	6707-6	56 SD Skid Bar	1
5	5285-3	U-Joint Shaft, 90 Degree (14-7/8) (Includes Items # 22, F069 & F295)	1	38	6705-8	56 SD Discharge Shield	1
6	5052-6	HD Gearbox, LH (1:1.2 Ratio)	1	39	5727-1	Washer Shim (5/8 ID)	4
7	6701-51	56 SD Gearbox and Tube Assembly, HD (Includes Items # 6, 8-16, 20, 21, F136, F179 & F211)	1	<b>Fasteners</b>			
8	6054	Spline Coupling	5	F002	10-24 Keps Nut		8
9	P007	Gasket, Cap (Peerless #788030)	6	F004	1/4-20 Keps Nut		4
10	5069	Gearbox Connector Tube (14-1/2)	1	F009	5/16-18 Whiz Locknut		1
11	6733-9	Connecting Shaft (12-1/8)	1	F013	3/8-16 Whiz Locknut		2
12	5058-6	HD Tee Gearbox (1:1.2 Ratio)	1	F014	3/8-16 ESNA Nut		2
13	5060	Gearbox Connector Tube (2-5/16)	1	F018	5/8-18 Hex Nut		3
14	6733-3	Connecting Shaft (6-1/4)	1	F020	5/16-18 ESNA Nut		1
15	5063	Gearbox Connector Tube (8-5/8)	1	F025	10-24 x 3/8 PPHMS		2
16	5053-6	HD Gearbox, RH (1:1.2 Ratio)	1	F029	1/4-20 x 1/2 Hex Bolt		2
17	6786	56 SD Gearbox Cover (Includes Items # 18 & 19)	1	F032	1/4-20 x 3/4 Hex Bolt		2
18	5747-10	Rubber Mat, No-Hole (3 x 6)	2	F038	3/8-16 x 1 Hex Bolt		6
19	8788-1	Rubber Mat (1 x 2)	1	F039	3/8-16 x 1-1/4 Hex Bolt		2
20	5704-1	Gearbox Cover Support	2	F050	1/4 SAE Washer		4
21	5051-6	HD Tee Gearbox, Shear	1	F055	5/8 SAE Washer		3
22	8067-13	Shear Pin w/Cotter (Set of 5) (Includes Item # F069)	*	F056	5/8 Split Lock Washer		3
23	5830	Grease Fitting	1	F059	3/8 Wave Spring Washer		4
<b>Deck Housing Components</b>				F069	3/32 x 1/2 Cotter Pin		1
24	8670-8	Tilt-Up Hook	1	F076	3/8-16 x 5/8 SQH Set Screw		*
25	5162-11	Roller Wheel (5" Poly) (Includes Item # F059)	2	F136	AN960C416L Washer		24
26	8490	Roller Wheel Axle Bolt	2	F179	1/4-20 x 1 Hex Bolt		4
27	NS	Deck Serial Number Plate	1	F202	10-24 x 5/8 SHC Screw, GR5 SS		6
28	5705-0	Blade, 20" (RH Rotation)	3	F206	#2 x 3/16 Drive Pin		2
	5705-9	56 SD Blade Set with Hubs (Includes Items # 28, 29, F002 & F202)	*	F208	5/16-18 x 2-1/4 Hex Bolt		1
29	5706	Blade Hub & Trash Guard	3	F211	1/4-20 x 7/8 Hex Bolt		22
30	6715-3	Roller Wheel Bearing	4	F246	1/4-20 x 1/2 PTHMS		2
31	7775-1	Hitch Pin, LH (Silver) #6	2	F278	3/8 Split Lock Washer		6
				F295	3/16 x 1-1/2 Split Spring Pin		1
				F371	5/16-18 x 6 Hex Bolt		1
				F517	Washer 3/8 x 1-1/8 x 1/8		4
				* Service Part Only			
				<b>NOTE:</b> Order Item # 3 to use the splined deck PTO shaft with Model T23, T25i, T30i, D21d, C19, B19 and B23i.			
				<b>NOTE:</b> Order Item # 4 to use the splined deck PTO shaft with Model B18.			

# DS56 DECK ASSEMBLY

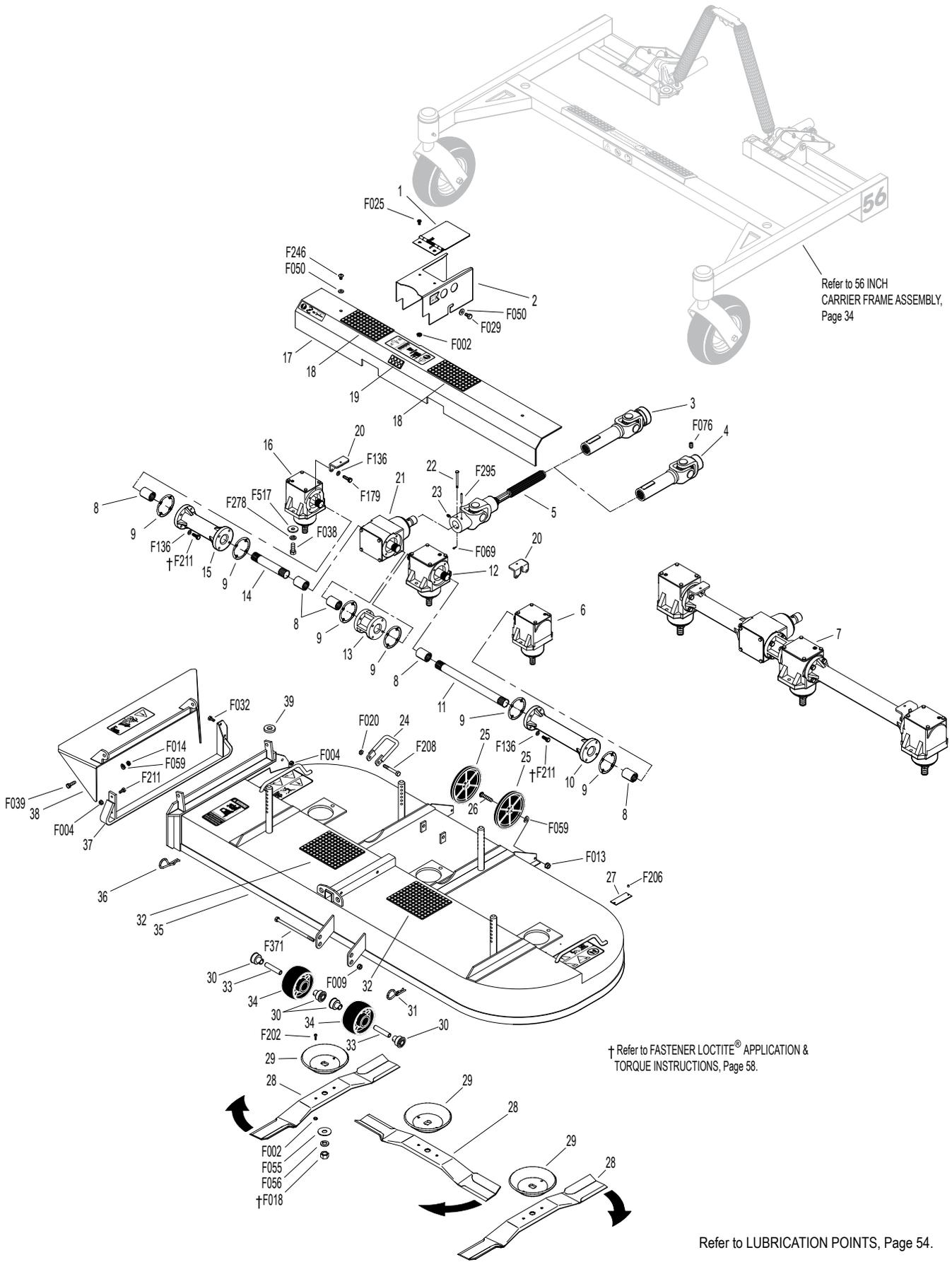

# 60 INCH COMPLETE CARRIER FRAME ASSEMBLY

ITEM NO.	PART NO.	DESCRIPTION	NO. REQ'D	ITEM NO.	PART NO.	DESCRIPTION	NO. REQ'D
<b>Spring and Pivot Mount Components</b>				37	2214-10	Rod End, Female (3/8-24)	4
1	2744-1	Spring Clip Bracket	1	38	2722-3	Pivot Shaft	2
2	5975-3	Cable Tie (50# x 7")	2	39	2655	Lift Chain	4
3	5743-1	Spring Cover	2	40	4407-4	Bow Tie Cotter Pin	2
4	5743-6	Extension Spring (1-1/2 x 7-3/4) (Includes Items # 2, F117 & F166)	2	41	2215-4	Height Adjustment Rod	2
5	5743-3	Eyebolt (3/8-16 x 2)	2	42	5146-1	10mm Ball Stud x 5/8	2
6	2723	Counter Weight Spring Mount	2	43	5146	10mm Ball Stud	2
7	2723-5	Locking Arm, LH (Includes Item # F432)	1	44	2215	Gas Spring Assembly	2
8	5830	Grease Fitting	10	45	2721	Lifting Arm (Includes Item # 8)	1
9	2667-1	Pivot Mount, LH (Includes Item # 8)	1	46	2721-2	Lifting Cross Tube	1
10	2723-4	Pivot Shaft	2	47	2723-3	Height Adjustment Arm (Includes Item # 48)	1
11	2667-2	Pivot Mount, RH (Includes Item # 8)	1	48	5850-3	Handle Grip, Foam (3-1/4)	1
12	2723-6	Locking Arm, RH (Includes Item # F432)	1	49	2722-7	Foot Pedal Pad	1
				50	2722-2	Deck Height Adjustment Trigger (Includes Item # 8)	1
<b>Carrier Frame Components</b>				<b>Fasteners</b>			
13	2215-2	Gas Spring Cover, RH	1	F004	1/4-20 Keps Nut		6
14	2723-2	Outer Height Adjustment Plate	1	F009	5/16-18 Whiz Locknut		13
15	7775-9	Wire Lock Pin (5/16 x 1-3/8)	1	F013	3/8-16 Whiz Locknut		14
16	2720-3	Height Adjustment Spacer	4	F014	3/8-16 ESNA Nut		2
17	2723-1	Inner Height Adjustment Plate	1	F035	5/16-18 x 1-1/4 Hex Bolt		2
18	2215-3	Gas Spring Cover, LH	1	F038	3/8-16 x 1 Hex Bolt		2
19	8740	Deck Pin Bushing (3/4 ID)	4	F039	3/8-16 x 1-1/4 Hex Bolt		2
20	2911-3	60SD Carrier Frame	1	F040	3/8-16 x 1-1/2 Hex Bolt		5
21	7775-5	Lock Pin (5/16 x 1-5/8)	1	F048	1/2 SAE Washer		2
22	8811-25	Tilt Bar W/Grip (35") (Includes Item # 23)	1	F050	1/4 SAE Washer		6
23	5850-5	Handle Grip (1 x 1 x 3-3/4)	1	F071	3/4 External Snap Ring		2
<b>Caster Wheel Components</b>				F090	1/4-20 x 2-1/2 Hex Bolt		4
24	8769-8	Dust Cap, Deck Caster	2	F117	Retainer Ring		2
25	8769-6	Bearing Cone (1" ID)	4	F132	1/4-20 x 2-3/4 Hex Bolt		2
26	8769-5	Bearing Cup (2 x 1-5/8)	4	F166	Retainer Ring		2
27	8769-7	Seal	2	F205	5/16-18 x 1/4 Set Screw (Knurl Point)		2
28	2770	Caster Wheel Fork	2	F215	3/8-16 x 1/2 x 1/2 S Bolt		2
29	7038	Tail Wheel Axle (3/4 x 5-9/16)	2	F218	7/16 Split Lock Washer		4
30	8037-1	Seal, Outer (1-3/4 x 1-1/8)	2	F219	7/16-14 x 1-1/4 Hex Bolt		4
31	8037	Bearing Cone (3/4 ID)	4	F226	5/16-18 x 7/8 Hex Bolt		5
32	8035	Tail Wheel & Tire (13 x 5.00-6) (W/Bearing Race)	2	F241	.375 x .875 x .10 Washer		18
33	8768-2	Seal, Reverse Lip	2	F263	1-1/4 External Snap Ring		6
34	8038-1	Spacer, Tail Wheel Axle (.750 x ID x 1.125 OD)	2	F268	5/16-18 x 3 Hex Bolt		1
35	8039	Nut, Tail Wheel Axle	2	F298	3/8-24 Jam Nut		4
<b>Deck Lift Components</b>				F344	3/4-16 Slotted Hex Nut		2
36	2722-1	Deck Height Adjustment, LH (Includes Item # 8)	1	F347	3/4 SAE Washer		2
				F348	1/8 x 1-1/2 Cotter Pin		2
				F378	3/8-16 x 6 Hex Bolt		1
				F432	3/16 x 1/2 Split Spring Pin		2
				F436	3/16 x 1-1/8 Spring Pin		4
				F437	Clevis Pin (1/4 x 1)		2
				F438	5/16-18 x 2-3/4 Hex Bolt		1

# 60 INCH COMPLETE CARRIER FRAME ASSEMBLY

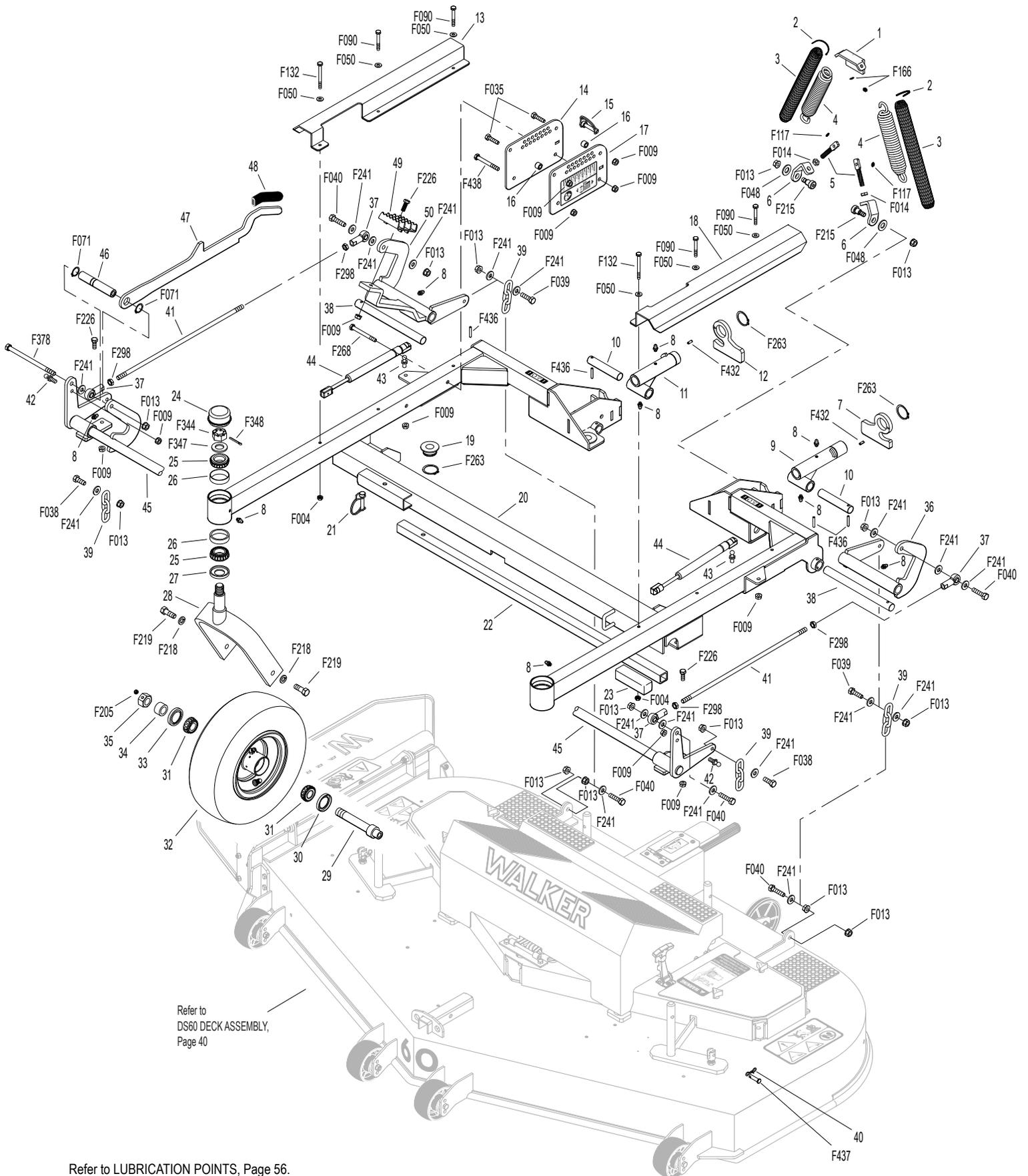

Refer to  
DS60 DECK ASSEMBLY,  
Page 40

Refer to LUBRICATION POINTS, Page 56.

Effective Date 04-01-13  
Use only genuine **Walker**® replacement parts.

# DS60 DECK ASSEMBLY

ITEM NO.	PART NO.	DESCRIPTION	NO. REQ'D	ITEM NO.	PART NO.	DESCRIPTION	NO. REQ'D
<b>Deck Housing Components</b>				46	2265	Bearing (20mm)	1
1	2110	Hood Latch Assembly	2	47	2245-2	Idler Pulley	1
2	2786-4	Locking Finger	2		2245-5	Idler Pulley Assembly (Includes Items # 41, 46, 47 & F445)	*
3	2786-3	Rubber Mat (2 x 7)	2	<b>Blade Spindle Components</b>			
4	2786-2	Rubber Mat (7 x 9-1/2)	2	48	2052-1	Blade Spindle	3
5	4845	Rubber Bumper (1.0 x .625)	4	49	5830	Grease Fitting	3
6	2786-5	Footrest, DSD60 (Includes Items # 3 & 4)	1	50	7705-15	Hi-Lift Blade 21" (RH Rotation)	3
7	2703-5	Knob, 10-24 x 1/2	4	<b>Fasteners</b>			
8	2724-11	Spindle Cover	2		F002	10-24 Keps Nut	12
9	5162-11	Roller Wheel (5") (Includes Item # F059)	2		F004	1/4-20 Keps Nut	15
10	8490	Roller Wheel Axle Bolt	2		F005	1/4-20 ESNA Nut	12
11	NS	Deck Serial Number Plate	1		F009	5/16-18 Whiz Locknut	14
12	8735-10	Rubber Mat (5 x 6)	2		F012	3/8-16 Keps Nut	1
13	2910-7	60SD Deck Housing (Includes Item # 12)	1		F013	3/8-16 Whiz Locknut	23
14	2720-5	Deck Height Adjustment Clevis	2		F014	3/8-16 ESNA Nut	2
15	6715-4	Axle Spacer Tube	4		F025	10-24 x 3/8 PPHMS	10
16	6715-3	Roller Wheel Bearing	8		F028	10-24 x 3/4 PPHMS	2
17	6715-2	Roller Wheel	4		F029	1/4-20 x 1/2 Hex Bolt	10
18	8670-12	Tilt-Up Hook	1		F031	1/4-20 x 5/8 Hex Bolt	6
19	2720-2	DSD60 Baffle	1		F033	1/4-20 x 1 PTH Bolt	12
20	2707-1	60SD Skid Bar	1		F034	5/16-18 x 3/4 Hex Bolt	2
21	2705-8	Front Backup Plate	1		F039	3/8-16 x 1-1/4 Hex Bolt	18
22	2705-7	Center Backup Plate	1		F041	3/8-16 x 1-3/4 Hex Bolt	3
23	2705-9	Rear Backup Plate	1		F045	3/16 x 3/16 x 3/4 Key	3
24	2809-2	Rubber Shield	1		F048	1/2 SAE Washer	3
25	2705-10	Chute Frame / Outer	1		F050	1/4 SAE Washer	2
<b>Blade Drive Components</b>					F051	3/8 SAE Washer	3
26	2618-1	Cover, PTO Shaft Guard	1		F059	3/8 Wave Spring Washer	4
27	2620-3	Rubber Flap	1		F065	3/16 x 3/4 Woodruff Key (#606)	3
28	2620-2	Backing Plate	1		F067	3/16 x 3/16 x 1 Key	1
29	2619-1	PTO Shaft Guard	1		F075	5/16-18 x 1/2 SQH Set Screw	2
	2618-2	PTO Shaft Guard Assembly (Includes Items # 26-29, F002, F025 & F028)	*		F123	1" External Snap Ring	4
30	8285-3	U-Joint Shaft Assembly, Spline (Includes Item # F318)	1		F206	#2 x 3/16 Drive Pin	2
31	5270	Bearing W/Collar (1")	2		F211	1/4-20 x 7/8 Hex Bolt	2
32	2726	PTO Bearing Housing	1		F226	5/16-18 x 7/8 Hex Bolt	4
33	2726-1	PTO Drive Shaft	1		F262	3/8-16 x 4 Hex Bolt All Thread	1
34	2240-4	Drive Pulley (Includes Items # F075 & F435)	1		F265	1/2-20 x 1-1/2 Hex Bolt	3
35	2724-14	Idler Mount Weldment	1		F306	3/8-16 x 3/4 Hex Bolt	4
36	5195-2	Compression Spring (1 x 6-3/8) (Black)	2		F318	3/8-16 x 3/4 SQH Set Screw	2
37	2724-17	Guide Rod Bushing	4		F336	3/8-16 Jam Nut	1
38	2724-18	Mount Base	1		F388	3/8-16 x 2-1/2 Hex Bolt	1
39	2724-16	Guide Rods	2		F404	5/8-18 Jam Nut	3
40	5841	Retainer Washer (3/8 x 1-1/4)	2		F405	3/8-16 x 1-1/2 FHA Screw, SS	2
41	2245-6	Idler Pulley Shaft	2		F408	7/16-20 Jam Nut	2
42	4245-1	Idler Pulley (4/Flat)	1		F435	1/4 x 1/4 x 1-1/4 Key	1
43	2240-7	Blade Drive Pulley (3.6) W/Shield	3		F445	1-7/8 Internal Snap Ring	1
44	8245	Idler Pulley (6")	2		F458	Washer 1-1/4 x 5/8 x 3/16	3
45	2731-3	Blade Drive Belt (1250L4-K)	1		F478	5/16-18 x 3-1/4 Hex Bolt	4

\* Service Part Only

# DS60 DECK ASSEMBLY

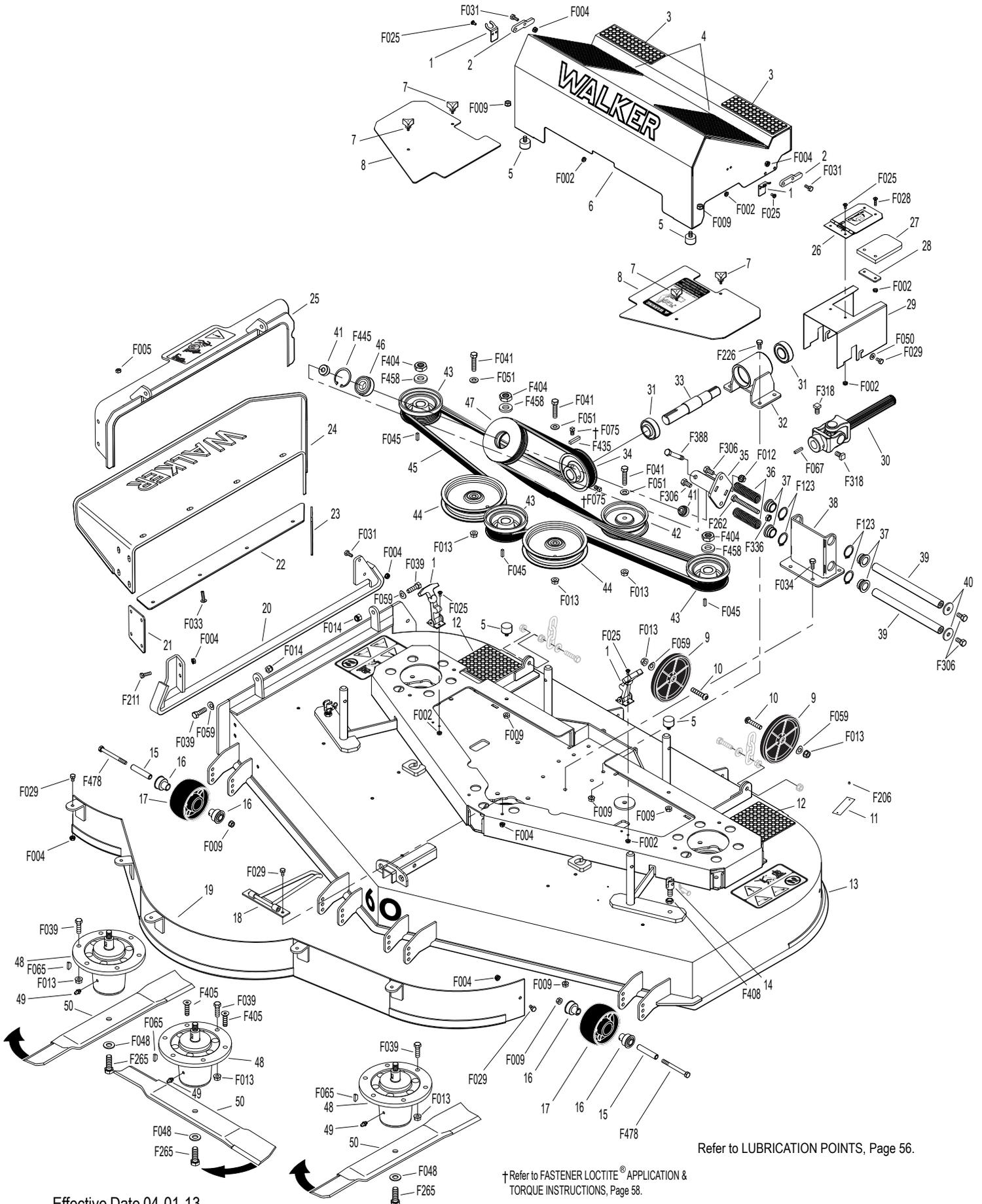

Refer to LUBRICATION POINTS, Page 56.

† Refer to FASTENER LOCTITE® APPLICATION & TORQUE INSTRUCTIONS, Page 58.

Effective Date 04-01-13  
Use only genuine Walker® replacement parts.

# DS60 MULCHING KIT

ITEM NO.	PART NO.	DESCRIPTION	NO. REQ'D	ITEM NO.	PART NO.	DESCRIPTION	NO. REQ'D
<p><b>Kit 2691-10 Mulching Kit (For DS60 Deck Assembly)</b>            Includes Items # 1-4, fasteners listed and instructions. May be ordered as a factory-installed option or as a kit for dealer installation. Contact your Walker dealer. Refer also to <b>DS60 DECK ASSEMBLY</b>, page 40.</p>				<p><b>Fasteners</b></p>			
1	7705-16	Blade, 21" Low Lift	3	F004		1/4-20 Keps Nut	13
2	2691-7	Left Hand Baffle	1	F029		1/4-20 x 1/2 Hex Bolt	13
3	2691-6	Center Baffle	1	F048		1/2 SAE Washer	3
4	2691-8	Right Hand Baffle	1	F265		1/2-20 x 1-1/2 Hex Bolt	3

# DS60 MULCHING KIT

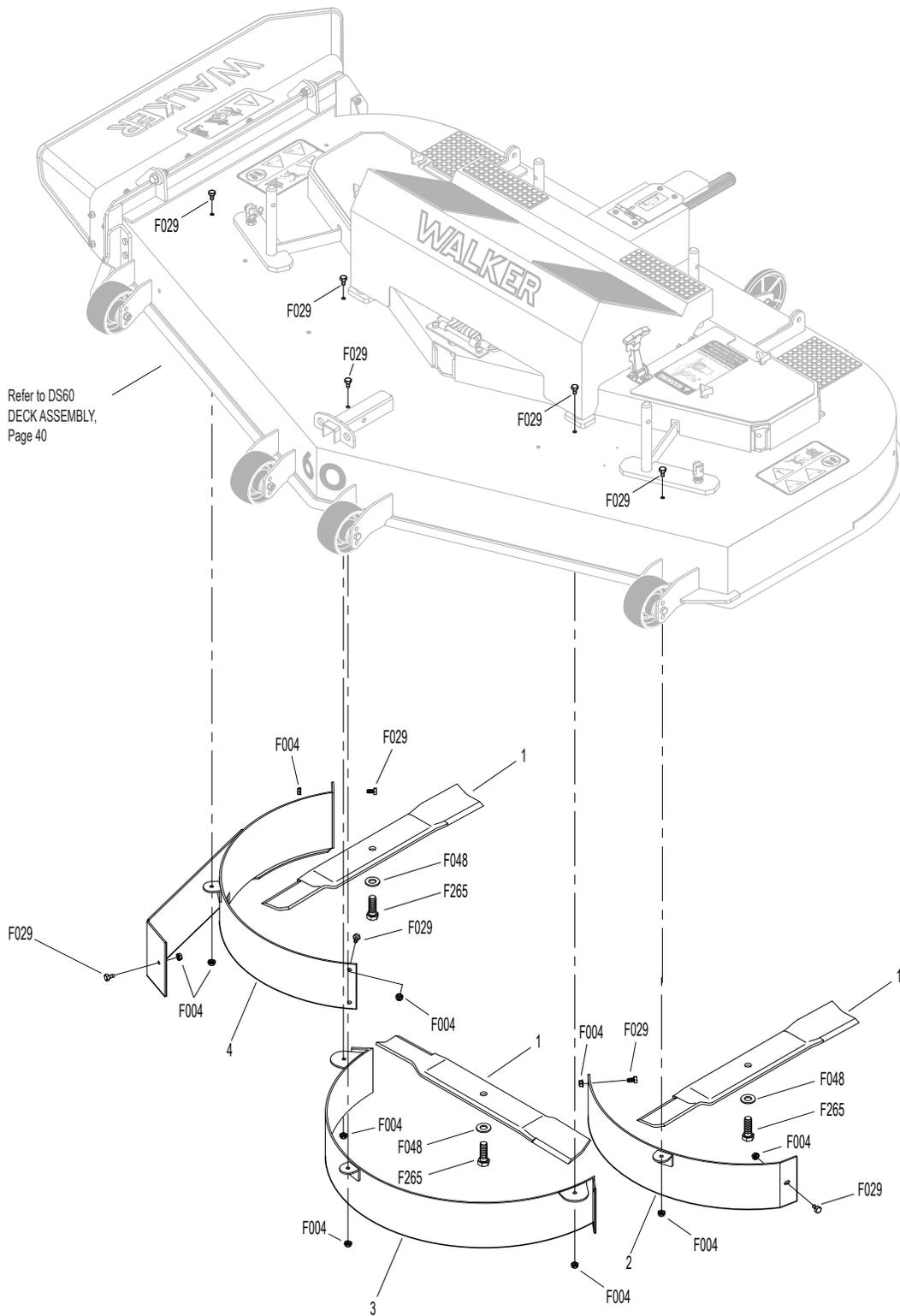

# 62 INCH COMPLETE CARRIER FRAME ASSEMBLY

ITEM NO.	PART NO.	DESCRIPTION	NO. REQ'D	ITEM NO.	PART NO.	DESCRIPTION	NO. REQ'D
<b>Spring and Pivot Mount Components</b>				<b>Caster Wheel Components</b>			
1	5975-3	Cable Tie (50# x 7")	4	17	8766	Axle Nut (3/4-16)	2
2	5744-1	Spring Clip Bracket	1	18	8768-2	Seal, Reverse Lip	4
3	5743-1	Spring Cover	2	19	8037	Bearing Cone (3/4 ID)	4
4	5743-4	Eyebolt (3/8-16 x 2-3/4)	2	20	8037-2	Bearing Race	4
5	8667-29	Pivot Mount Adj., LH	1	21	5830-3	Grease Fitting (45 Degree)	2
	8667-3	Pivot Mount Assembly, LH/Adj. (Includes Items # 5, 6, F353, F489 & F520)	*	22	8768	Caster Wheel, Pneumatic (11 x 4.00-5) (Includes Items # 20 & 21)	2
6	5830	Grease Fitting	8		8768-3	Tire, Pneumatic (11 x 4.00-5)	*
7	8667-28	Pivot Mount Adj., RH	1		8768-5	Caster Wheel (5 x 3)	*
	8667-4	Pivot Mount Assembly, RH/Adj. (Includes Items # 6, 7, F353, F489 & F520)	*	23	8767	Axle, Caster Wheel (5-1/8)	2
8	5743-6	Extension Spring (1-1/2 x 7-3/4) (Includes Items # 1, F117 & F166)	2	24	8765-11	Caster Wheel Fork	2
<b>Carrier Frame Components</b>				25	8769-7	Seal	2
9	8674-11	Lever, Deck Lock, LH	1	26	8769-6	Bearing Cone (1" ID)	4
10	7406-1	Handle Grip (Red)	2	27	8769-5	Bearing Cup, (2 x 1-5/8)	4
11	8911-12	62 SD Carrier Frame	1	28	8769-8	Dust Cap, Deck Caster	2
	8911-10	62 SD Carrier Frame, with Pivots (Includes Items # 5, 7, 9, 10, 15, F317, F335 & F336)	*	<b>Fasteners</b>			
12	5850-5	Handle Grip (1 x 1 x 3-3/4)	1	F117	Retainer Ring		2
13	8911-25	Tilt Bar With Grip (42-1/2) (Includes Item # 12)	1	F140	7/16-14 x 1 Hex Bolt		4
14	7775-5	Lock Pin (5/16 x 1-5/8)	1	F166	Retainer Ring		2
15	8674-10	Lever, Deck Lock, RH	1	F218	7/16 Split Lock Washer		4
16	8740	Deck Pin Bushing (3/4 ID)	4	F263	1-1/4 External Snap Ring		4
				F317	3/16 x 1 Split Spring Pin		2
				F335	3/8-16 x 7/8 Set Screw, SS		2
				F336	3/8-16 Jam Nut		2
				F344	3/4-16 Slotted Hex Nut		2
				F347	3/4 SAE Washer		2
				F348	1/8 x 1-1/2 Cotter Pin		2
				F353	3/8-16 ESNA LP Nut		2
				F489	Washer 1/4 x 7/8 x .090		2
				F520	1/4-28 x 3/8 Hex Bolt		2

\* Service Part Only

**NOTE:** The E-Z Pin Puller P/N 8770 can be ordered to assist removing and installing height adjustment hitch pins on larger decks. This item stows on tractor when not in use.



# DS62 DECK ASSEMBLY

ITEM NO.	PART NO.	DESCRIPTION	NO. REQ'D	ITEM NO.	PART NO.	DESCRIPTION	NO. REQ'D
<b>Blade Drive Components</b>				43	8910-10	62 SD Deck Housing (Includes Items # 35 & 38)	1
1	8789-5	Pulley Guard	1	44	8792-10	Baffle, DSD62	1
2	8786-15	Footrest Assembly (Includes Item # 18)	1	45	8052-2	Blade Spindle	3
3	8754-3	Edge Molding	2	46	5705-3	Blade, 22" (RH Rotation)	3
4	8785-5	62 SD Cover Plate (Includes Items # 3 & F354)	1		5705-13	62 SD Blade Set	*
5	8245	Idler Pulley (6")	3	47	8728	Machine Bushing (1/2 x 1-1/2)	3
6	8240	Blade Drive Pulley (4-1/2)	3	48	8707	52/62 SD Skid Bar	1
7	8762	Dampening Spring (Gas)	1	49	8709	52/62 SD Discharge Shield	1
8	5146	10mm Ball Stud	2	50	5052-3	1.375 x .750 x .187 Washer	12
9	8373-3	Idler Arm (2-Hole)	1	51	8670-10	Tilt-Up Hook	1
10	5830	Grease Fitting	2	<b>Fasteners</b>			
11	8374-1	Idler Arm Guide	1	F004		1/4-20 Keps Nut	11
12	7201-3	Fiberglide Bearing	2	F009		5/16-18 Whiz Locknut	3
13	7201-4	Inner Race (1-1/2)	1	F012		3/8-16 Keps Nut	11
14	5841	Retainer Washer (3/8 x 1-1/4)	1	F013		3/8-16 Whiz Locknut	14
15	8731	Blade Drive Belt, (23VX1180)	1	F014		3/8-16 ESNA Nut	3
16	6240-2	Drive Pulley (4-1/2 / 3V) (Includes Items # F114 & F277)	1	F020		5/16-18 ESNA Nut	2
17	8787	Deck Cover Knob	3	F023		10-24 ESNA Nut	2
18	8786-10	Rubber Mat (6 x 10-1/2)	2	F029		1/4-20 x 1/2 Hex Bolt	5
<b>Gearbox and Dolly Wheel Components</b>				F032		1/4-20 x 3/4 Hex Bolt	2
19	6206-1	Air Vent Valve	1	F034		5/16-18 x 3/4 Hex Bolt	1
20	8745-25	Dolly Wheel/PTO Guard Assembly (Includes Items # 23, 24, 26, 29, 30, 33, F012, F013, F046, F052, F168, F226, F339 & F355)	*	F038		3/8-16 x 1 Hex Bolt	6
21	8285-2	U-Joint Shaft Assy, T-Scope (Includes Items # 22, F076 & F277)	1	F039		3/8-16 x 1-1/4 Hex Bolt	2
22	5830-3	Grease Fitting (45 Degree)	2	F040		3/8-16 x 1-1/2 Hex Bolt	12
23	5103-4	Pivot Bushing (3/8 ID)	2	F041		3/8-16 x 1-3/4 Hex Bolt	3
24	8788	Rubber Bumper (Self-Adhesive Mount)	1	F046		3/8-16 x 3-1/2 Hex Bolt	4
25	8745-14	Retract Lever	1	F051		3/8 SAE Washer	9
26	5850-3	Handle Grip, Foam (3-1/4)	1	F052		5/16 External Star Lock Washer	2
27	8745-12	Actuator Link	1	F059		3/8 Wave Spring Washer	2
28	8745-13	Dolly Wheel Mount (Includes Item # 10)	1	F068		1/8 x 1 Cotter Pin	1
29	6715	Roller Wheel (3-7/8)	1	F076		3/8-16 x 5/8 SQH Set Screw	*
30	8745-15	Axle Spacer Tube	1	F108		3/8-16 x 2 Hex Bolt	1
31	5229	Extension Spring (1/2 x 2-1/4)	1	F114		5/16-18 x 5/8 SQH Set Screw	2
32	8745-20	Mount Bracket (Includes Items # 24, F052, F068 & F339)	1	F134		AN960816L Washer	1
33	8745-40	PTO Cover Plate	1	F168		5/16 Split Lock Washer	8
34	8051-11	Right Angle Gearbox (Includes Item # 19)	1	F206		#2 x 3/16 Drive Pin	2
<b>Deck Housing Components</b>				F226		5/16-18 x 7/8 Hex Bolt	8
35	8790	Rubber Cushion Strip	3	F241		.375 x .875 x .10 Washer	8
36	8727	Washer Shim (13/16 x 1/4)	4	F246		1/4-20 x 1/2 PTHMS	2
37	8775	Hitch Pin (#219)	4	F252		10-24 x 3/4 PFHMS	2
38	8735-10	Rubber Mat (5 x 6)	2	F265		1/2-20 x 1-1/2 Hex Bolt	3
39	8720-30	Anti-Scalp Wheel Mount	3	F276		5/8-11 Jam Nut	3
40	8745-30	Axle Spacer Tube	3	F277		3/16 x 5/8 Woodruff Key (#605)	5
41	6715-1	Roller Wheel (5")	3	F339		5/16-18 x 3/4 Self-Tapping Bolt	2
42	NS	Deck Serial Number Plate	1	F354		5/16 Knurled Thread Insert	2
				F355		3/8-16 x 4 Hex Bolt	1
				F356		1/4-20 x 5/8 PTHMS, SS	2
				F458		Washer 1-1/4 x 5/8 x 3/16	3
				* Service Part Only			



# 74 INCH COMPLETE CARRIER FRAME ASSEMBLY

ITEM NO.	PART NO.	DESCRIPTION	NO. REQ'D	ITEM NO.	PART NO.	DESCRIPTION	NO. REQ'D
<b>Spring and Pivot Mount Components</b>				<b>Caster Wheel Components</b>			
1	5975-3	Cable Tie (50# x 7")	4	18	8766	Axle Nut (3/4-16)	2
2	5744-1	Spring Clip Bracket	1	19	8768-2	Seal, Reverse Lip	4
3	5743-1	Spring Cover	2	20	8037	Bearing Cone (3/4 ID)	4
4	5743-3	Eyebolt (3/8-16 x 2)	2	21	8037-2	Bearing Race	4
5	5830	Grease Fitting	8	22	5830-3	Grease Fitting (45 Degree)	2
6	8667-29	Pivot Mount Adj., LH	1	23	8768	Caster Wheel, Pneumatic (11 x 4.00-5)	2
	8667-3	Pivot Mount Assembly, LH/Adj. (Includes Items # 5, 6, F014, F489 & F520)	*		8768-3	Tire, Pneumatic (11 x 4.00-5)	*
7	8667-28	Pivot Mount Adj., RH	1		8768-5	Caster Wheel (5 x 3)	*
	8667-4	Pivot Mount Assembly, RH/Adj. (Includes Items # 5, 7, F014, F489 & F520)	*	24	8767	Axle, Caster Wheel (5-1/8)	2
8	5743-6	Extension Spring (1-1/2 x 7-3/4) (Includes Items # 1, F117 & F166)	2	25	8765-11	Caster Wheel Fork	2
				26	8769-7	Seal	2
				27	8769-6	Bearing Cone (1" ID)	4
				28	8769-5	Bearing Cup (2 x 1-5/8)	4
				29	8769-8	Dust Cap, Deck Caster	2
<b>Carrier Frame Components</b>				<b>Fasteners</b>			
9	8674-11	Lever, Deck Lock, LH	1	F014	3/8-16 ESNA Nut		2
10	7406-1	Handle Grip (Red)	2	F117	Retainer Ring		2
11	7803-1	74 SD Carrier Frame (Includes Item # 15)	1	F140	7/16-14 x 1 Hex Bolt		4
12	5850-5	Handle Grip (1 x 1 x 3-3/4)	1	F166	Retainer Ring		2
13	8811-25	Tilt Bar with Grip (35") (Includes Item # 12)	1	F218	7/16 Split Lock Washer		4
14	7775-5	Lock Pin (5/16 x 1-5/8)	1	F263	1-1/4 External Snap Ring		4
15	5748-10	Rubber Mat (1-1/2 x 6)	2	F317	3/16 x 1 Split Spring Pin		2
16	8674-10	Lever, Deck Lock, RH	1	F335	3/8-16 x 7/8 Set Screw, SS		2
17	8740	Deck Pin Bushing (3/4 ID)	4	F336	3/8-16 Jam Nut		2
				F344	3/4-16 Slotted Hex Nut		2
				F347	3/4 SAE Washer		2
				F348	1/8 x 1-1/2 Cotter Pin		2
				F489	Washer 1/4 x 7/8 x .090		2
				F520	1/4-28 x 3/8 Hex Bolt		2

\* Service Part Only

**NOTE:** The E-Z Pin Puller P/N 8770 can be ordered to assist removing and installing height adjustment hitch pins on larger decks. This item stows on tractor when not in use.



# DS74 DECK ASSEMBLY

ITEM NO.	PART NO.	DESCRIPTION	NO. REQ'D	ITEM NO.	PART NO.	DESCRIPTION	NO. REQ'D
<b>Gearbox and Drive Components</b>				34	5705-0	Blade 20" (RH Rotation)	4
1	8618-1	Cover, PTO Shaft Guard	1		5705-16	74 SD Blade Set with Hubs (Includes Items # 34, 35, F002 & F202)	*
2	8619	PTO Shaft Guard	1	35	5706	Blade Hub & Trash Guard	4
	8618	PTO Shaft Guard Assembly (Includes Items # 1, 2, F002 & F025)	*	36	6715-3	Roller Wheel Bearing	4
3	7275-16	U-Joint Tube Assy, Spline	1	37	6715-4	Axle Spacer Tube	2
4	5285-15	U-Joint Shaft Assy, 90 Degree, Spline (Includes Items # 9, F069 & F295)	1	38	6715-2	Roller Wheel	2
5	7865-6	74 SD Gearbox Cover, RH (Includes Items # 6 & 8)	1	39	8788-1	Rubber Mat (1 x 2)	1
6	5747-10	Rubber Mat, No-Hole (3 x 6)	2	40	5704-32	74 Gearbox and Tube Assembly, HD (Includes Items # 5-8 & 11-22)	1
7	7865-5	74 SD Gearbox Cover, LH (Includes Items # 6 & 8)	1	41	7807-1	74 SD Skid Bar	1
8	8790	Rubber Cushion Strip	2	42	7809-1	74 SD Discharge Shield	1
9	8067-13	Shear Pin w/Cotter (Set of 5) (Includes Item # F069)	*	43	8775	Hitch Pin (#219)	4
10	5830	Grease Fitting	3	44	8727	Washer Shim (13/16 x 1/4)	4
<b>HD Drive Components</b>				<b>Fasteners</b>			
11	5053-6	Gearbox, RH (1:1.2) HD	1	F002	10-24 Keps Nut		10
12	P007	Gasket, Cap (P#788030)	8	F004	1/4-20 Keps Nut		4
13	5058-6	Tee Gearbox (1:1.2)	2	F009	5/16-18 Whiz Locknut		2
14	5051-6	Tee Gearbox, Shear	1	F012	3/8-16 Keps Nut		2
15	5052-6	Gearbox, LH (1:1.2) HD	1	F014	3/8-16 ESNA Nut		2
16	5704-1	Gearbox Cover Support	3	F018	5/8-18 Hex Nut		4
17	6054	Spline Coupling	7	F020	5/16-18 ESNA Nut		1
18	5069	Connector Tube (14-1/2)	2	F025	10-24 x 3/8 PPHMS		2
19	6733-9	Connecting Shaft (12-1/8)	2	F029	1/4-20 x 1/2 Hex Bolt		2
20	5063	Connector Tube (8-5/8)	1	F031	1/4-20 x 5/8 Hex Bolt		2
21	6733-3	Connecting Shaft (6-1/4)	1	F038	3/8-16 x 1 Hex Bolt		10
22	5060	Connector Tube (2-5/16)	1	F039	3/8-16 x 1-1/4 Hex Bolt		2
<b>Deck Housing Components</b>				F047	3/8-16 x 4-1/2 Hex Bolt		2
23	8786-10	Rubber Mat (6 x 10-1/2)	4	F050	1/4 SAE Washer		5
24	8670-8	Tilt-Up Hook	1	F055	5/8 SAE Washer		4
25	7803-3	74 SD Deck Housing (Includes Items # 23 & 39)	1	F056	5/8 Split Lock Washer		4
26	NS	Deck Serial Number Plate	1	F059	3/8 Wave Spring Washer		2
27	7866-1	Lock Lever, Rear Caster	2	F063	3/8 Int. Star Lock Washer		2
28	7775-5	Lock Pin (5/16 x 1-5/8)	2	F069	3/32 x 1/2 Cotter Pin		1
29	5683	Pivot Bearing	4	F119	Rear Caster Spacer		4
30	7866	74 SD Rear Fork Mount (Includes Items # 10 & 29)	2	F136	AN960C416L Washer		32
31	7870	74 SD Rear Fork	2	F179	1/4-20 x 1 Hex Bolt		6
32	5714-3	Axle Spacer Tube	2	F191	3/8 x 1-1/2 x 3/16 Washer		2
33	7868	74 SD Caster Wheel/Rear	2	F202	10-24 x 5/8 SHC Screw, GR5 SS		8
				F206	#2 x 3/16 Drive Pin		2
				F208	5/16-18 x 2-1/4 Hex Bolt		1
				F211	1/4-20 x 7/8 Hex Bolt		28
				F246	1/4-20 x 1/2 PTHMS		3
				F278	3/8 Split Lock Washer		8
				F295	3/16 x 1-1/2 Split Spring Pin		1
				F478	5/16-18 x 3-1/4 Hex Bolt		2
				F517	Washer 3/8 x 1-1/8 x 1/8		8

\* Service Part Only

# DS74 DECK ASSEMBLY

Refer to 74 INCH  
CARRIER FRAME ASSEMBLY,  
Page 48

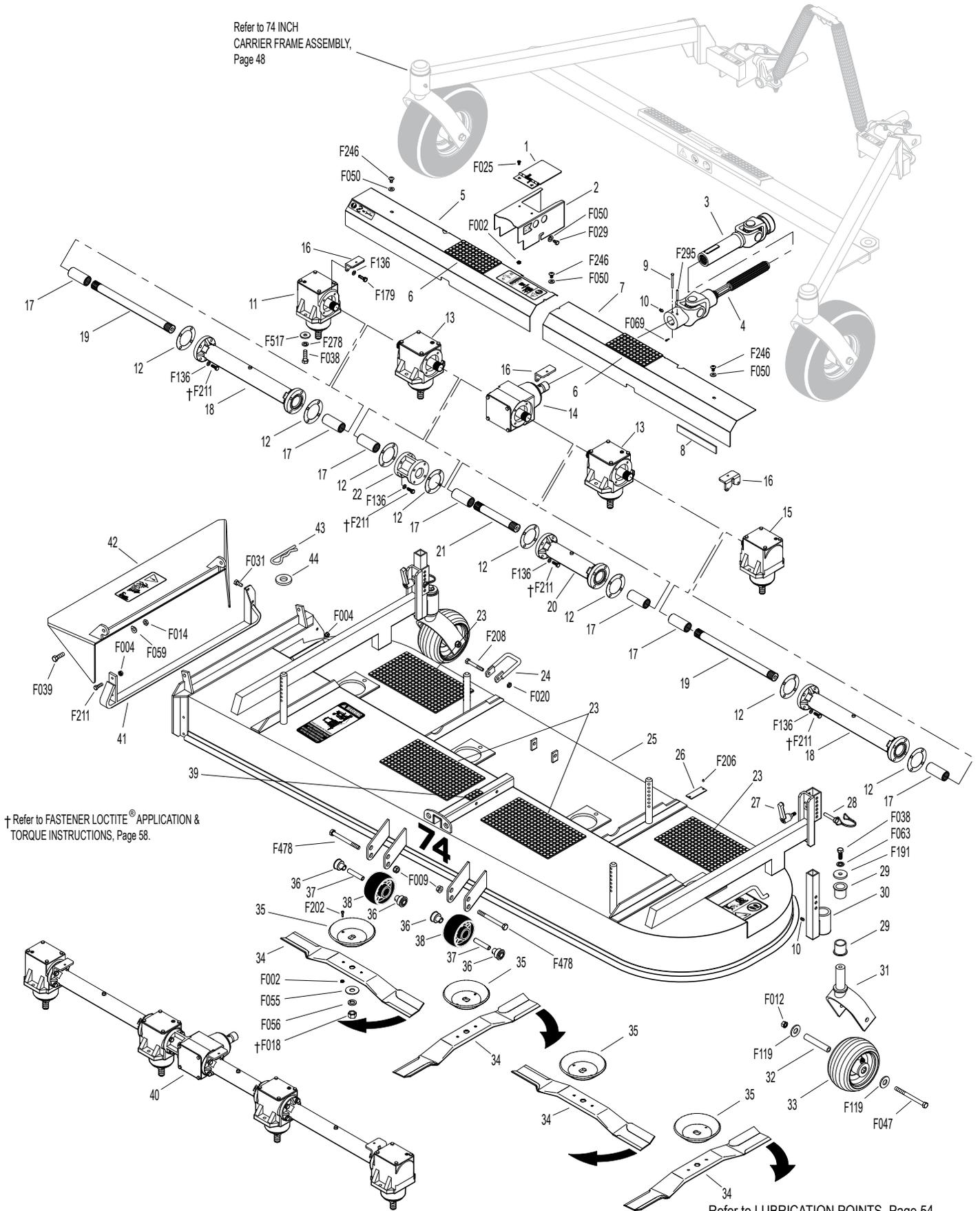

† Refer to FASTENER LOCTITE® APPLICATION & TORQUE INSTRUCTIONS, Page 58.

Refer to LUBRICATION POINTS, Page 54.

# OPTIONAL BREAK-AWAY BLADES

ITEM NO.	PART NO.	DESCRIPTION	NO. REQ'D	ITEM NO.	PART NO.	DESCRIPTION	NO. REQ'D
----------	----------	-------------	-----------	----------	----------	-------------	-----------

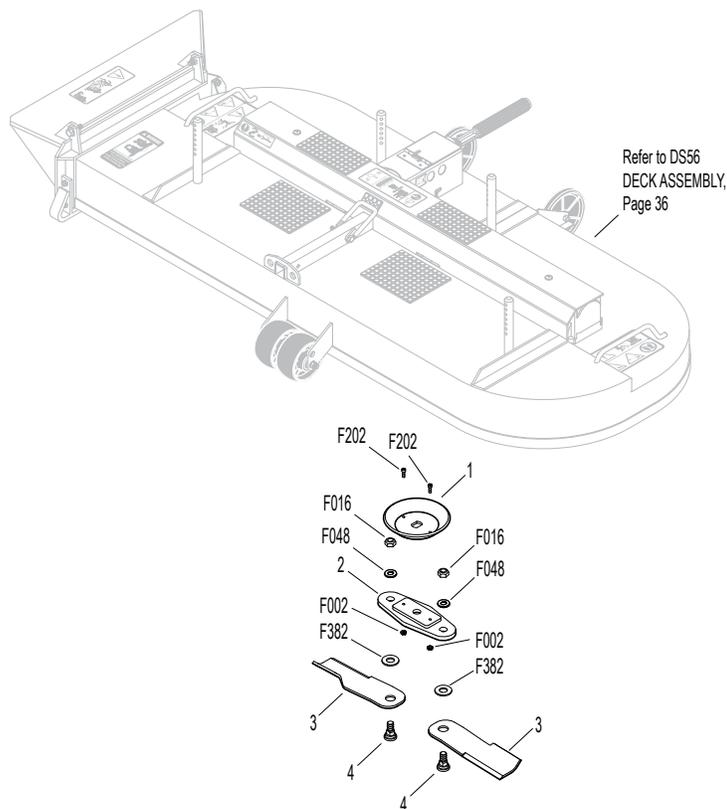

### DS 42" Break-Away Blade Kit (5705-33)

1	5706	Blade Hub & Trash Guard	
2	5706-27	Blade Hub, 42"	
3	5705-30	Break Away Blade	
4	5705-17	Special Bolt (1/2-13 x 1-7/16)	

### DS 48" Break-Away Blade Kit (7705-8)

1	5706	Blade Hub & Trash Guard	
2	5706-25	Blade Hub, 48"	
3	5705-30	Break Away Blade	
4	5705-17	Special Bolt (1/2-13 x 1-7/16)	

### DS 56" Break-Away Blade Kit (5705-32)

1	5706	Blade Hub & Trash Guard	3
2	5706-26	Blade Hub, 36, 56 & 74	3
3	5705-30	Break Away Blade	6
4	5705-17	Special Bolt (1/2-13 x 1-7/16)	6

### DS 74" Break-Away Blade Kit (5705-34)

2	1	5706	Blade Hub & Trash Guard	4
2	2	5706-26	Blade Hub, 36, 56 & 74	4
4	3	5705-30	Break Away Blade	8
4	4	5705-17	Special Bolt (1/2-13 x 1-7/16)	8

### Fasteners

F002	10-24	Keps Nut	*
F016	1/2-13	Self-Locking Nut	*
F048	1/2	SAE Washer	*
F202	10-24 x 5/8	SHC Screw, GR5 SS	*
F382	.650 x 1.36	Belleville Washer	*

\* Quantities vary

**NOTE:** Optional blade kit featuring blades mounted on a break-away hub, for use in mowing applications with lots of ground and debris contact, to minimize impact and shock loading.

**NOTE:** Break-Away blades are designed for use on Side Discharge decks only.

# BLADE USAGE CHART

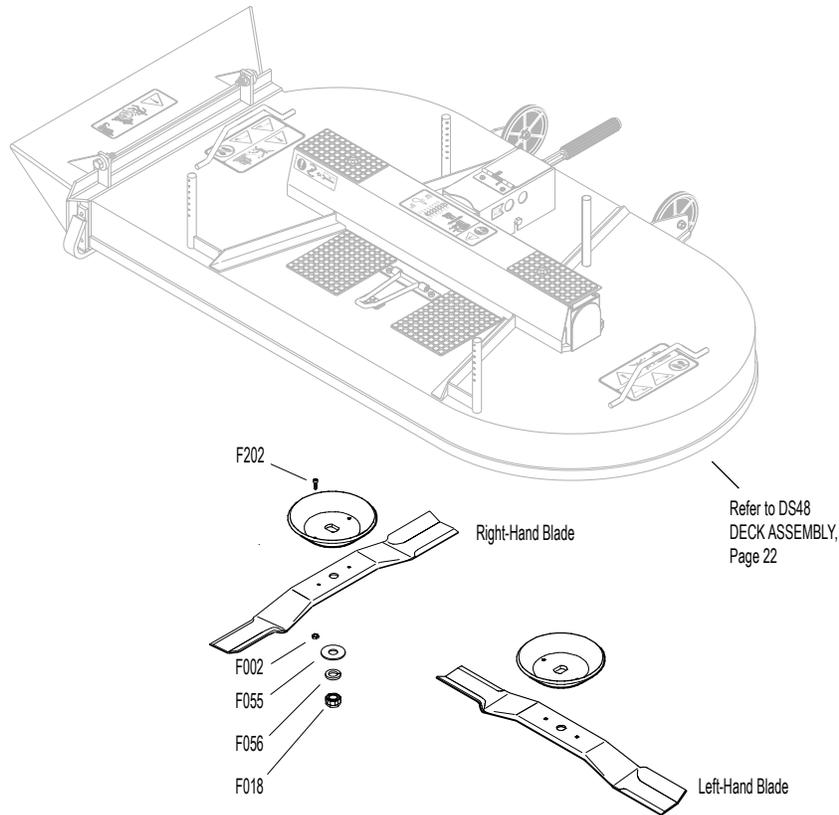

TWO BLADE DECKS	RH BLADE	LH BLADE	BLADE SET
DS36	5705-1	5705-1	5705-5
DS42	5705-3	5705-3	5705-7
DS42 BELT DRIVE	7705-22	7705-22	
DS48	7705-1	7705-1	7705-5

THREE & FOUR BLADE DECKS	SINGLE BLADE	BLADE SET
DS52	5705-14	8738-7*
DS52 MULCHING UPPER BLADE	5705-15	8738-8*
DS52 MULCHING LOWER BLADE	5705-14	8738-7*
DR52	7705-14	
DS56	5705-0	5705-9*
DS60	7705-15	
DS60 MULCHING KIT	7705-16	
DS62	5705-3	5705-13*
DS74	5705-0	5705-16

Right hand and left hand orientated with operator on seat.

All blade sets include 5706 (Blade Hub & Trash Guard), F002 & F202 unless otherwise specified.

\* Blade set consists of three (3) blades

Effective Date 04-01-13

Use only genuine **Walker**® replacement parts.

# LUBRICATION POINTS

ITEM NO.	LOCATION	LUBRICATION TYPE	NO. PLACES
----------	----------	------------------	------------

## 36", DS42, 48" & 56" Assemblies

1	Deck Caster Wheel Fork Pivot	Grease	2
2	Blade Drive Gearbox	Oil*	2
3	Tee Gearbox, Deck	Oil*	1
4	Deck Caster Wheel Bearing	Grease	2
5	Universal Joint Shaft Assembly	Grease**	1
6	Pivot Assembly, Tilt-Up Deck	Grease	4
7	Deck Support Arm Socket	Grease	2

## DS52 & DS62 Assemblies

1	Deck Caster Wheel Fork Pivot	Grease	2
4	Deck Caster Wheel Bearing	Grease	2
5	Universal Joint Shaft Assembly	Grease**	2
6	Pivot Assembly, Tilt-Up Deck	Grease	4
7	Deck Support Arm Socket	Grease	2
8	Idler Arm, 2-Hole	Grease	1
9	Blade Spindle	Grease	3
10	Right Angle Gearbox	Oil***	1
11	Dolly Wheel Retract Lever and Linkage	Oil	1
12	Dolly Wheel Pivot	Grease	1

ITEM NO.	LOCATION	LUBRICATION TYPE	NO. PLACES
----------	----------	------------------	------------

## DS74 Assembly

1	Deck Caster Wheel Fork Pivot	Grease	2
2	Blade Drive Gearbox	Oil*	4
3	Tee Gearbox, Deck	Oil*	1
4	Deck Caster Wheel Bearing	Grease	2
5	Universal Joint Shaft Assembly	Grease**	1
6	Pivot Assembly, Tilt-Up Deck	Grease	4
7	Deck Support Arm Socket	Grease	2
13	Rear Deck Caster Wheel Axle	Grease	2

\* Gearboxes are permanently lubricated and sealed requiring no scheduled lubrication. Oil level should be checked only when an oil leak is noted.

\*\* Grease every eight (8) hours.

\*\*\* Check oil level every 100 hours. Refer to **OPERATORS MANUAL** for Lubrication Instructions.

**NOTE:** Exact location of some Lubrication Points may vary slightly from those shown in the illustration. Decks shown in the illustration are for reference only; for further information on location of parts not shown here, refer to the parts listings for individual Carrier Frames and Deck Assemblies.

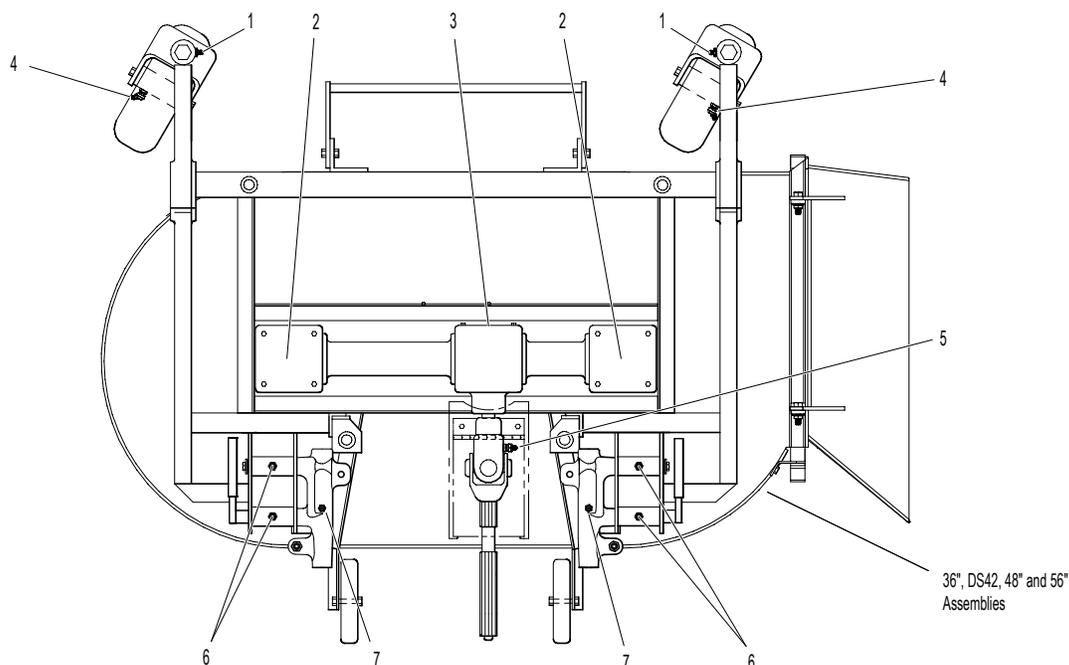

# LUBRICATION POINTS

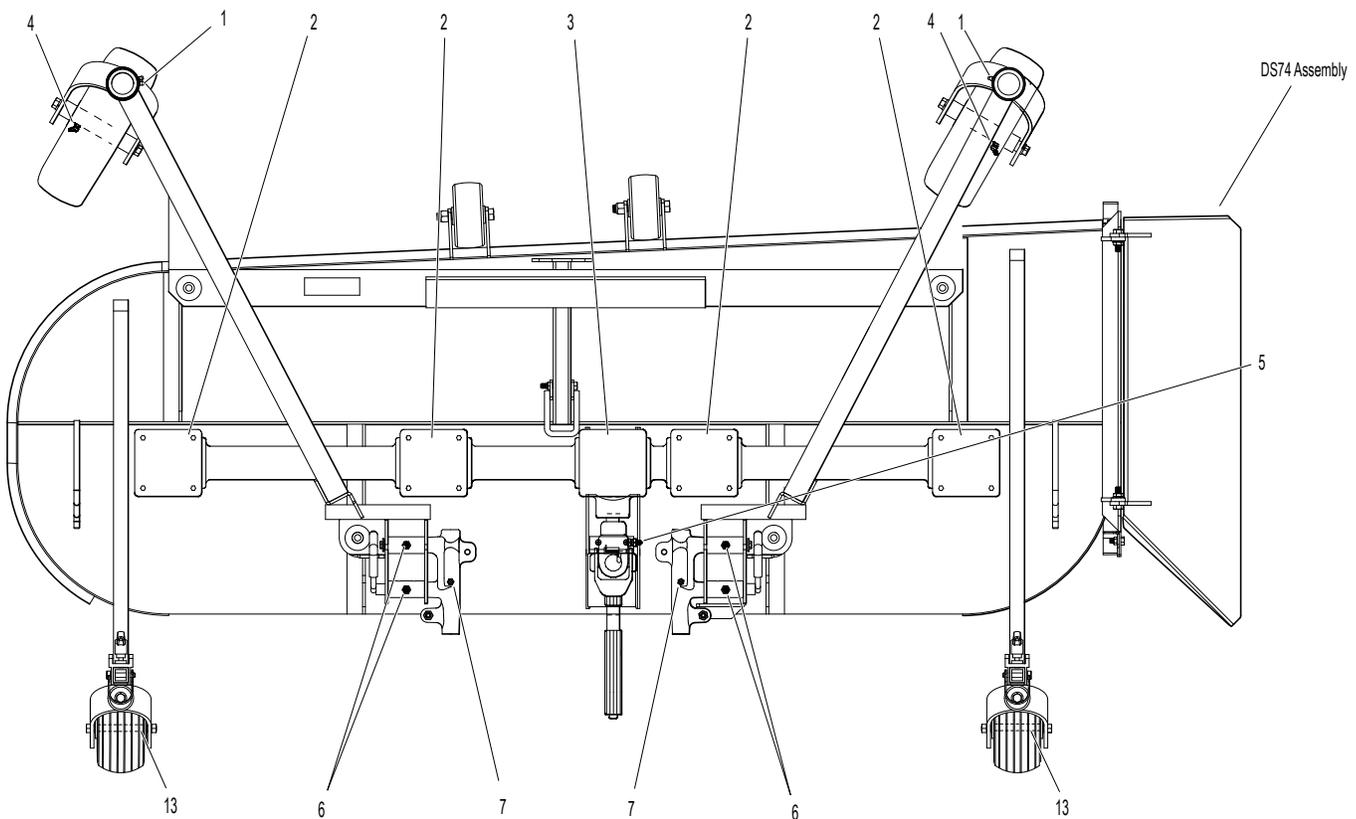
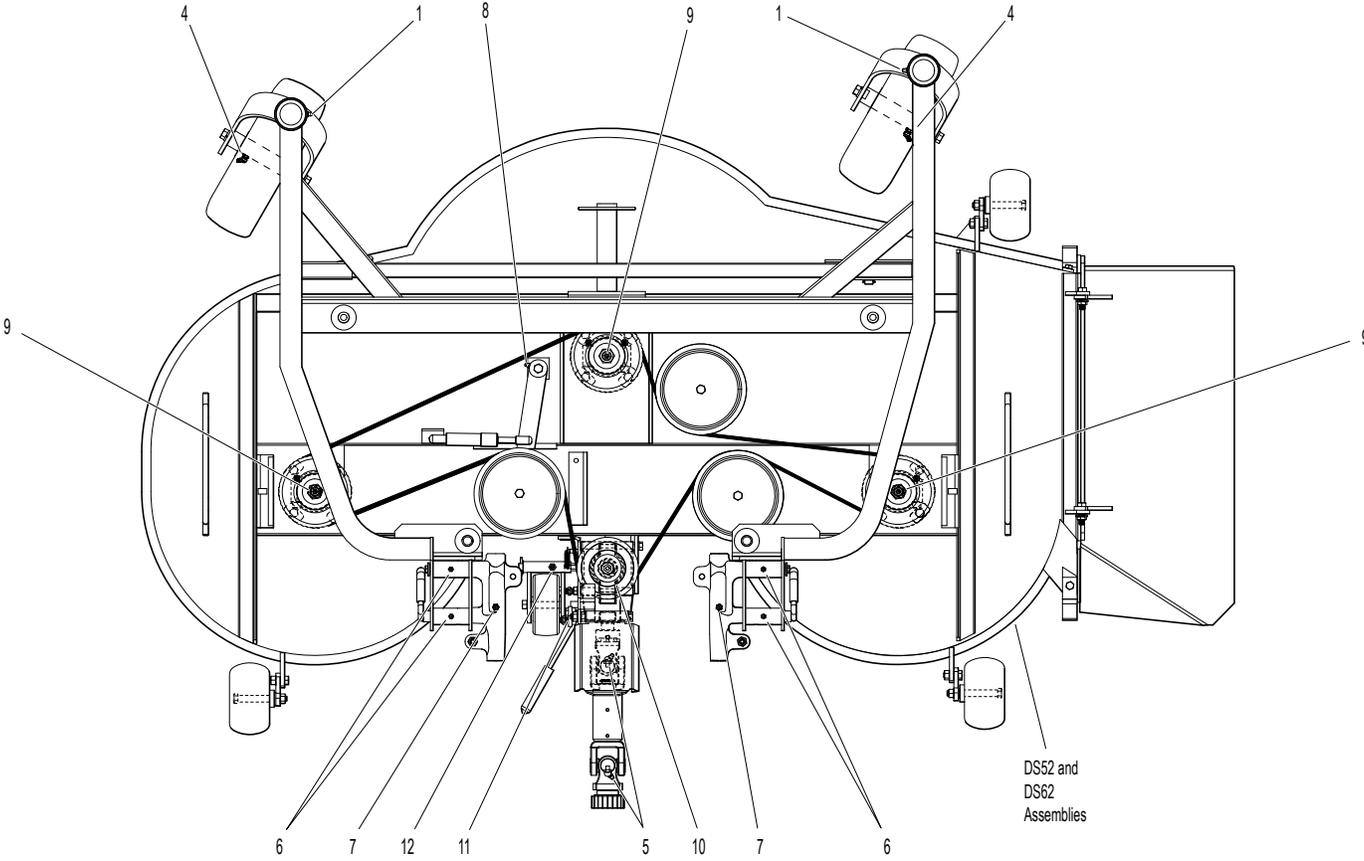

Effective Date 04-01-13  
 Use only genuine Walker® replacement parts.

# LUBRICATION POINTS

ITEM NO.	LOCATION	LUBRICATION TYPE	NO. PLACES
----------	----------	------------------	------------

## DS42 Belt Drive Assembly

1	Deck Caster Wheel Fork Pivot	Grease	2
2	Deck Caster Wheel Bearing	Grease	2
3	Blade Spindle	Grease	2
4	Pivot Assembly, Tilt-Up Deck	Grease	4
5	Deck Support Arm Socket	Grease	2
6	Universal Joint Shaft Assembly	Grease*	1

## DR52 Assembly

1	Deck Caster Wheel Fork Pivot	Grease	2
2	Deck Caster Wheel Bearing	Grease	2
3	Blade Spindle	Grease	3
4	Pivot Assembly, Tilt-Up Deck	Grease	2
5	Deck Support Arm Socket	Grease	2
6	Universal Joint Shaft Assembly	Grease*	1
7	Front Deck Lift Pivot	Grease	2
8	Rear Deck Lift Pivot	Grease	2

ITEM NO.	LOCATION	LUBRICATION TYPE	NO. PLACES
----------	----------	------------------	------------

## DS60 Assembly

1	Deck Caster Wheel Fork Pivot	Grease	2
2	Deck Caster Wheel Bearing	Grease	2
3	Blade Spindle	Grease	3
4	Pivot Assembly, Tilt-Up Deck	Grease	2
5	Deck Support Arm Socket	Grease	2
6	Universal Joint Shaft Assembly	Grease*	1
7	Front Deck Lift Pivot	Grease	2
8	Rear Deck Lift Pivot	Grease	2

\* Grease every eight (8) hours.

**NOTE:** Exact location of some Lubrication Points may vary slightly from those shown in the illustration. Decks shown in the illustration are for reference only; for further information on location of parts not shown here, refer to the parts listings for individual Carrier Frames and Deck Assemblies.

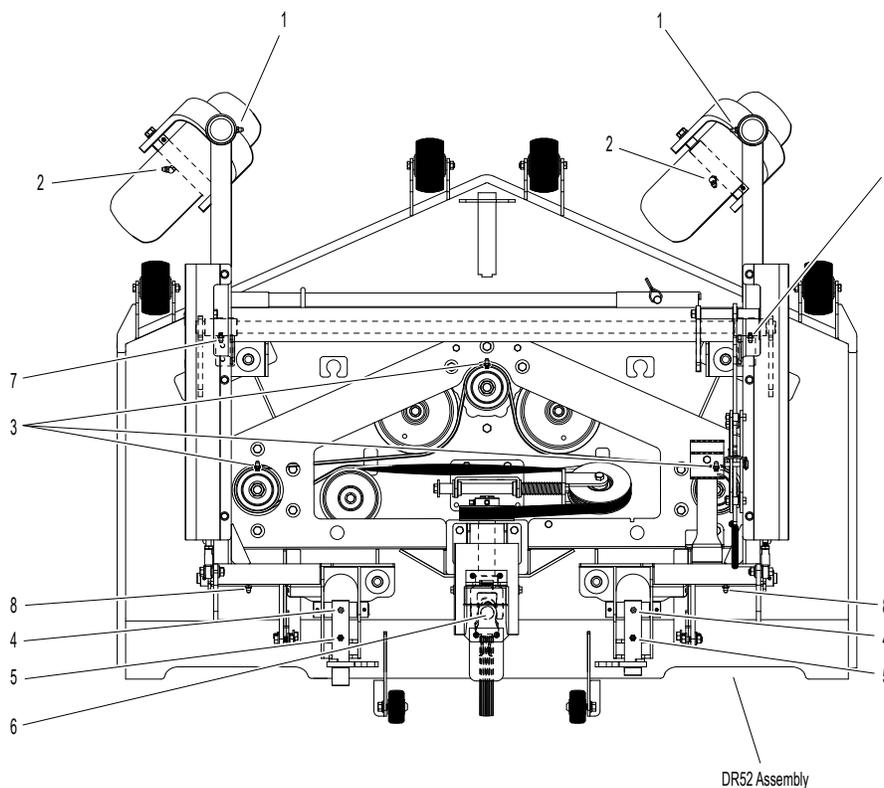

# LUBRICATION POINTS

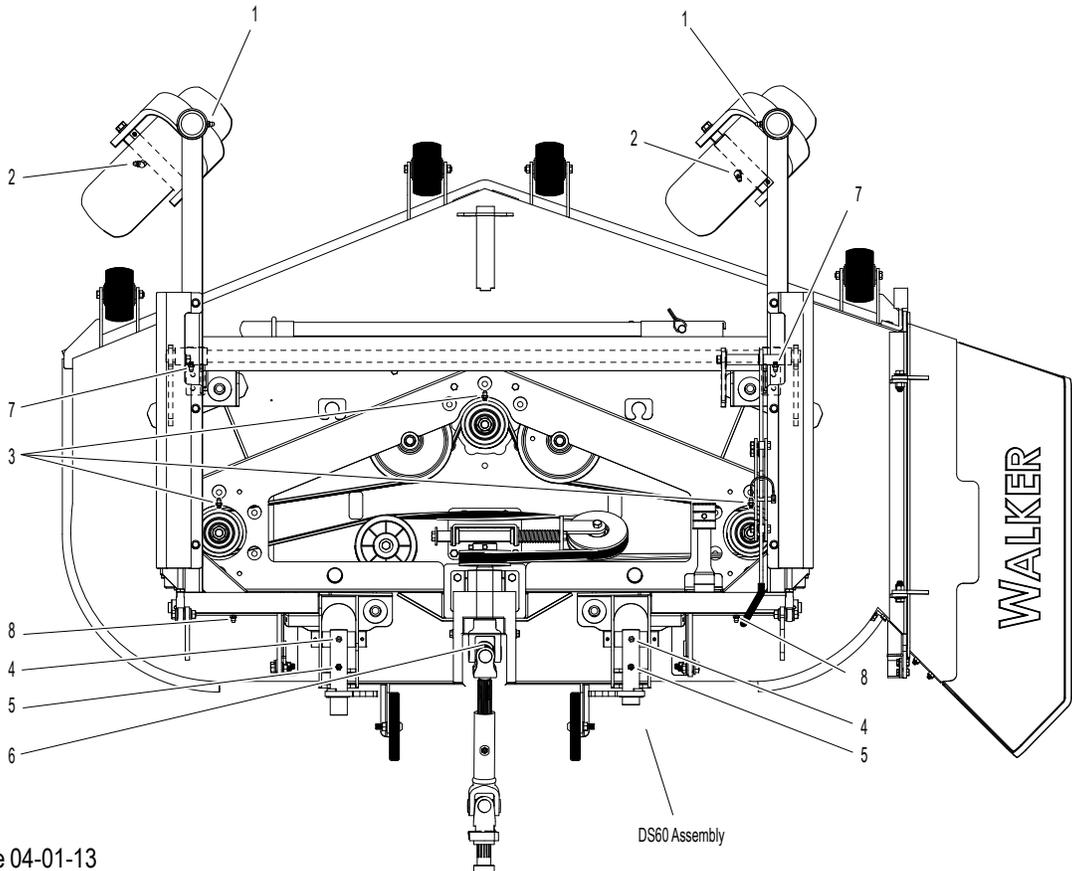
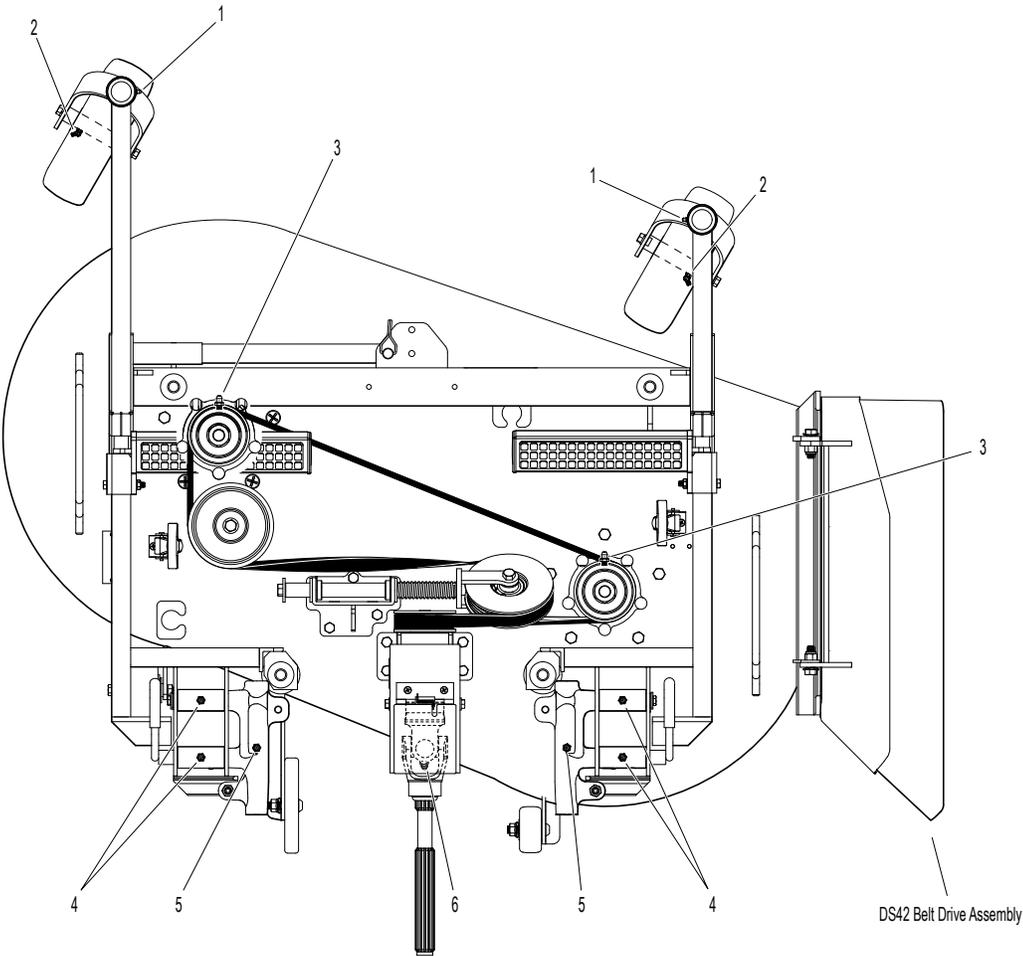

Effective Date 04-01-13  
 Use only genuine Walker® replacement parts.

# FASTENER LOCTITE® APPLICATION & TORQUE INSTRUCTIONS

ITEM NO.	DESCRIPTION
----------	-------------

## DS HD Gear Drive Assemblies

Item # 1 applies to all HD deck models **EXCEPT DS42 Belt Drive, DS52 and DS62.**

- 1 Apply Loctite® Threadlocker # 242 (Blue) to Item # 1 used on HD Gearbox Connector Tubes. Torque to 115 lb-in. (13.0 N·m).

## DS Deck Assemblies

Items # 2 & 3 apply to all deck models **EXCEPT DS42 Belt Drive, DS52 and DS62.**

- 2 Apply Loctite® Threadlocker # 242 (Blue) to P/N F211 (1/4-20 x 7/8 Hex Bolt, used on Gearbox Connector Tubes) prior to assembly. Torque to 90 lb-in. (10.2 N·m).
- 3 Torque P/N F018 (5/8-18 Hex Nut) used on underside of blades) to 60 lb·ft (81.4 N·m). **DO NOT** apply Loctite®.

ITEM NO.	DESCRIPTION
----------	-------------

## DR52 & DS60 Deck Assemblies

- 4 Apply Loctite® Threadlocker # 242 (Blue) to P/N F075 (5/16-18 x 1/2 SQH Set Screw, used on Drive Pulley) prior to assembly. Torque to 190 lb-in. (21.5 N·m).

## DSD52 & DSD62 Deck Assemblies

- 5 Apply Loctite® Threadlocker # 242 (Blue) to P/N F114 (5/16-18 x 5/8 SQH Set Screw, used on Drive Pulley) prior to assembly. Torque to 190 lb-in. (21.5 N·m).
- 6 Apply Loctite® Threadlocker # 242 (Blue) to P/N F076 (3/8-16 x 5/8 SQH Set Screw, used on U-Joint Shaft Assy, T-Scope) prior to assembly. Torque to 400 lb-in. (45.2 N·m).
- 7 Torque P/N F339 (5/16-18 x 3/4 Self-Tapping Bolt, used on Mount Bracket & PTO Guard) to 200 lb-in. (22.6 N·m). **DO NOT** apply Loctite®.
- 8 Apply Loctite® Threadlocker # 242 (Blue) to P/N F226 (5/16-18 x 7/8 Hex Bolt, used on Right Angle Gearbox) prior to assembly. Torque to 18 lb·ft (24.4 N·m).

**NOTE:** Models DS48 and DS52 are shown here. Refer to individual deck assemblies for exact locations and quantities of items listed above.

# FASTENER LOCTITE® APPLICATION & TORQUE INSTRUCTIONS

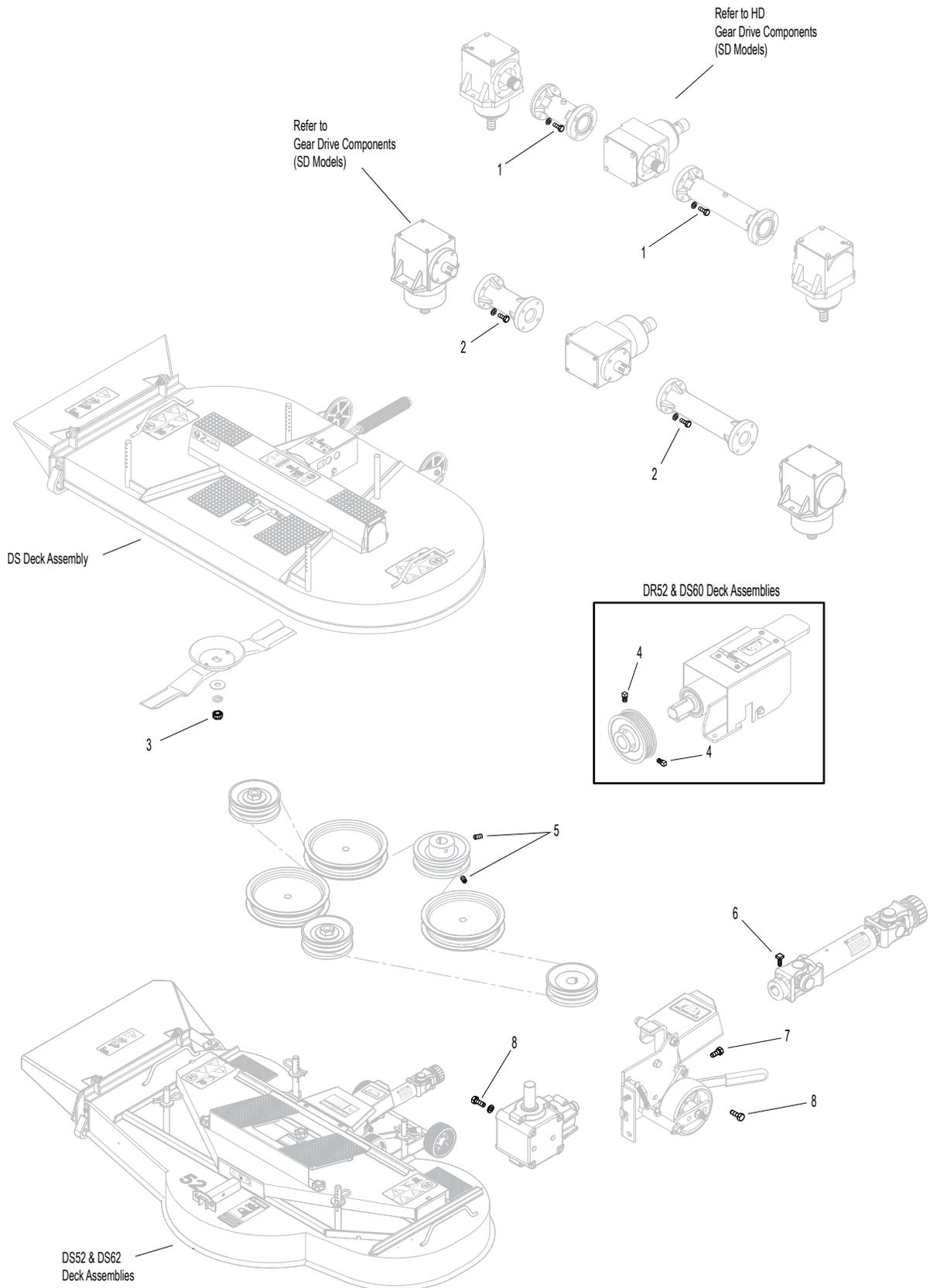



## **LIMITED WARRANTY FOR WALKER COMMERCIAL RIDER MOWER**

**1. WHAT THIS WARRANTY COVERS, AND FOR HOW LONG:**

Walker Manufacturing company will, at its option, repair or replace, without charge, any part covered by this warranty which is found to be defective in material and/or workmanship within one (1) year after date of sale to the original retail purchaser unless the product is used for rental purposes, in which case this warranty is limited to ninety (90) days. At Walker's request, customer will make the defective part available for inspection by Walker and/or return the defective part to Walker, transportation charges prepaid. All parts and components of the Walker Mower are covered by this warranty.

**2. WHAT THIS WARRANTY DOES NOT COVER:**

- A. This warranty does not cover defects caused by depreciation or damage caused by normal wear, accidents, improper maintenance, improper use or abuse of the product, alterations, or failure to follow the instructions contained in the Operator's Manual for operation and maintenance.
- B. The customer shall pay any charges for making service calls and/or for transporting the mower to and from the place where the inspection and/or warranty work is performed.

**3. HOW TO OBTAIN SERVICE UNDER THIS WARRANTY:**

Warranty service can be arranged by contacting the dealer where you purchased the mower or by contacting Walker Manufacturing Company, 5925 East Harmony Road, Ft. Collins, CO 80528. Proof of the date of purchase may be required to verify warranty coverage.

**4. WARRANTY LIMITATION:**

- A. **THERE IS NO OTHER EXPRESS WARRANTY. ANY WARRANTY THAT MAY BE IMPLIED FROM THIS PURCHASE INCLUDING MERCHANTABILITY AND FITNESS FOR A PARTICULAR PURPOSE IS HEREBY LIMITED TO THE DURATION OF THIS WARRANTY AND TO THE EXTENT PERMITTED BY LAW ANY AND ALL IMPLIED WARRANTIES ARE EXCLUDED.** Some states do not allow limitations on how long an implied warranty lasts, so the above limitations may not apply to you.
- B. **WALKER WILL NOT BE LIABLE FOR ANY INCIDENTAL, CONSEQUENTIAL, OR SPECIAL DAMAGES AND/OR EXPENSES IN CONNECTION WITH THE PURCHASE OR USE OF THE MOWER.** Some states do not allow the exclusion or limitation of incidental or consequential damages, so the above limitation(s) or exclusion(s) may not apply to you.
- C. Only the warranty expressed in this limited warranty shall apply and no dealer, distributor, or individual is authorized to amend, modify, or extend this warranty in any way. Accordingly, additional statements such as dealer advertising or presentations, whether oral or written, do not constitute warranties by Walker, and should not be relied upon.
- D. This warranty gives you specific legal rights, and you may also have other rights which vary from state to state.

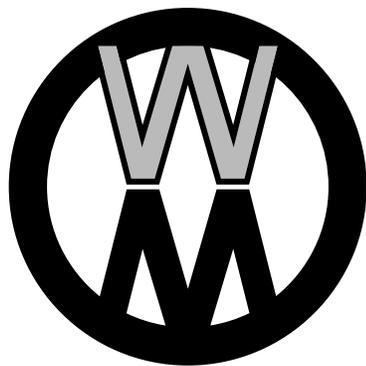

**WALKER**

**WALKER MFG. CO. • 5925 E. HARMONY ROAD, FORT COLLINS, CO 80528 • (970) 221-5614**  
**PRINTED IN USA** [www.walkermowers.com](http://www.walkermowers.com) ©2014 WALKER MFG. CO