

REVISIONS			
REV	DESCRIPTION	DATE	APPROVAL
—	DRAWING RELEASE	11-14-02	DM
A	NOTE REVISIONS	4-16-04	DM
B	NOTE REVISIONS	6-17-09	CS
C	RE-TEST 9-19-13	10-24-13	CS
D	16 GA. STEEL JAMB/1.5X1.5X.072MIN BB	9-19-16	CS
E	Note: Alternate Concrete/Masonry Fasteners	09/25/17	CS

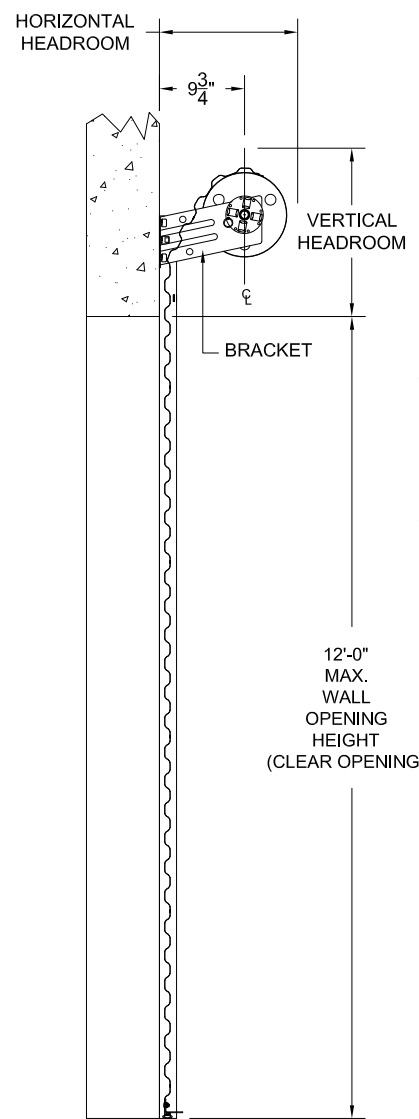

SIDE VIEW

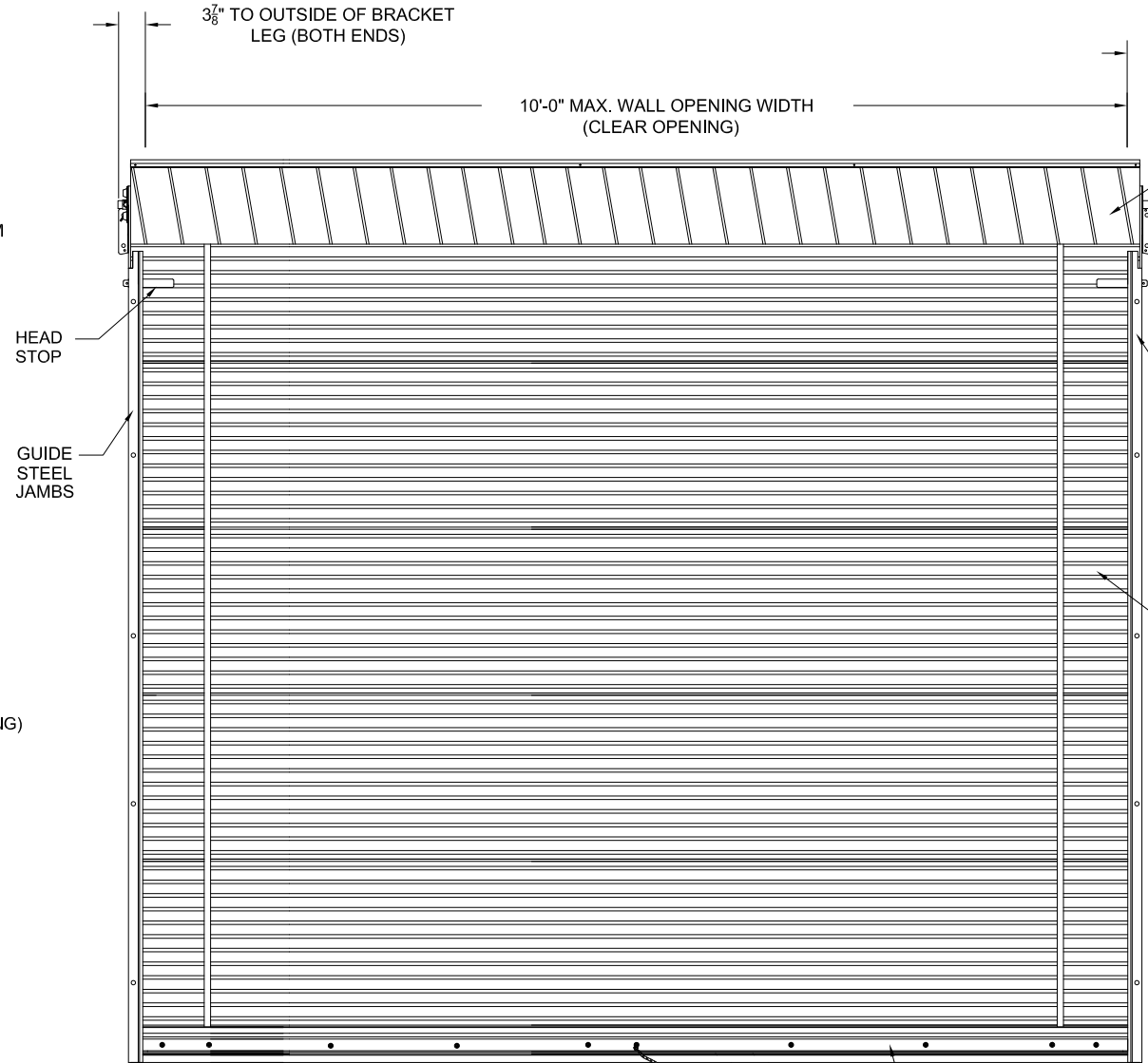

INSIDE ELEVATION

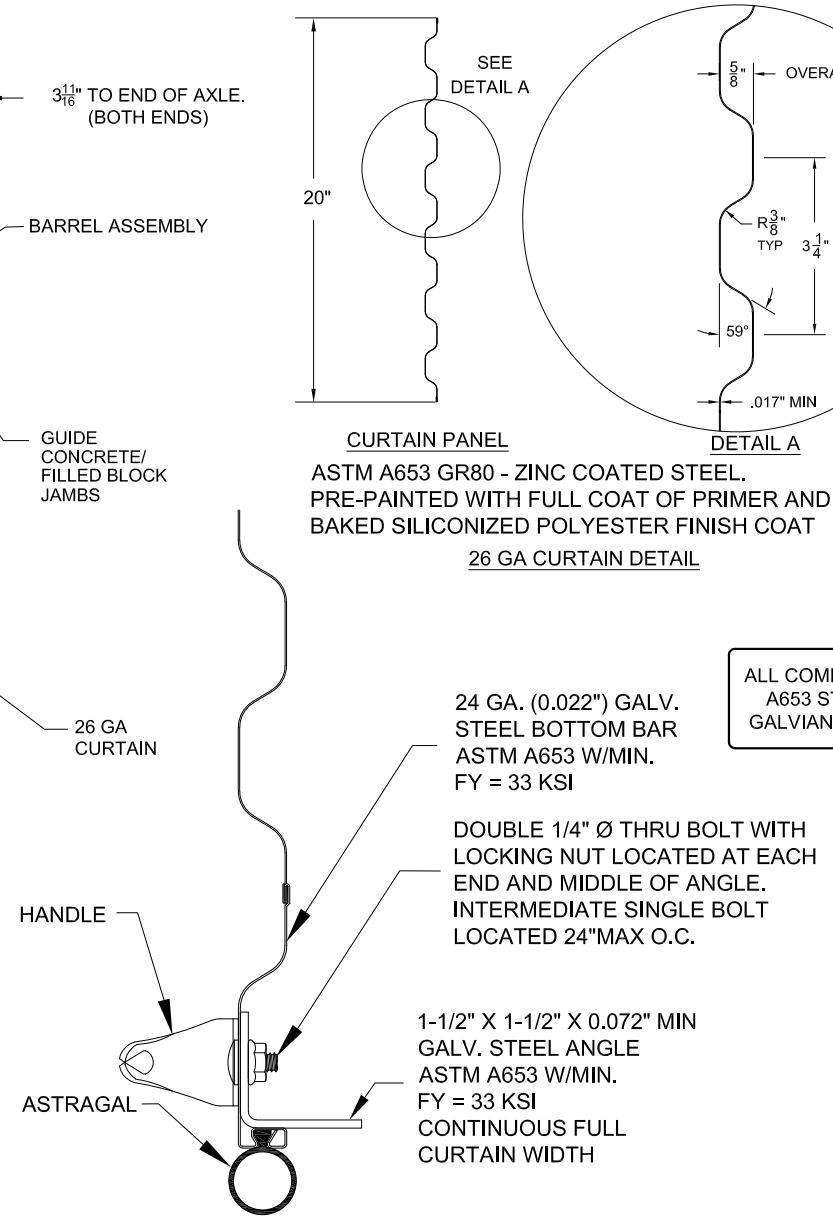

BOTTOM BAR ASSEMBLY

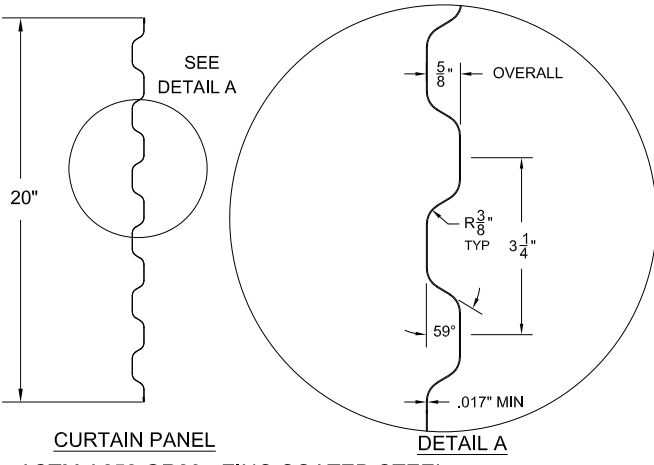

CURTAIN PANEL
ASTM A653 GR80 - ZINC COATED STEEL.
PRE-PAINTED WITH FULL COAT OF PRIMER AND
BAKED SILICONIZED POLYESTER FINISH COAT
26 GA CURTAIN DETAIL

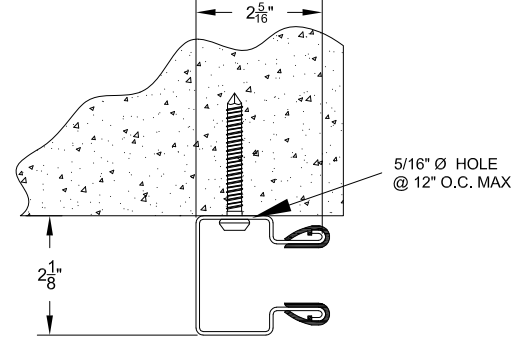

CONCRETE/FILLED BLOCK JAMBS
USING 5/16" X 2-1/4" TAPCON XL

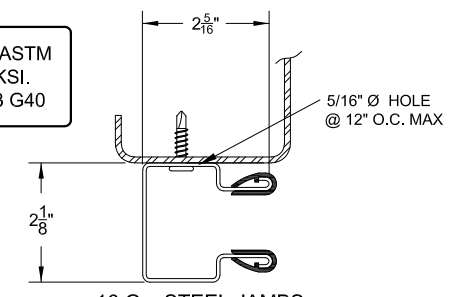

16 Ga. STEEL JAMBS
USING #12-14 X 1" TEKS PANCAKE HEAD

16 GA (0.054" MIN) GUIDE MOUNTING DETAIL

ALL COMPONENTS SHALL BE ASTM
A653 STEEL W/MIN FY = 33 KSI.
GALVIANIZED PER ASTM A653 G40

24 GA. (0.022") GALV.
STEEL BOTTOM BAR
ASTM A653 W/MIN.
FY = 33 KSI

DOUBLE 1/4" Ø THRU BOLT WITH
LOCKING NUT LOCATED AT EACH
END AND MIDDLE OF ANGLE.
INTERMEDIATE SINGLE BOLT
LOCATED 24" MAX O.C.

1-1/2" X 1-1/2" X 0.072" MIN
GALV. STEEL ANGLE
ASTM A653 W/MIN.
FY = 33 KSI
CONTINUOUS FULL
CURTAIN WIDTH

John E. Scates, P.E.
2560 King Arthur, STE 124-54
Lewisville, TX 75056
FL PE 51737_TX PE 56308/F2203

Professional Engineer's seal provided only for
verification of windload construction details.

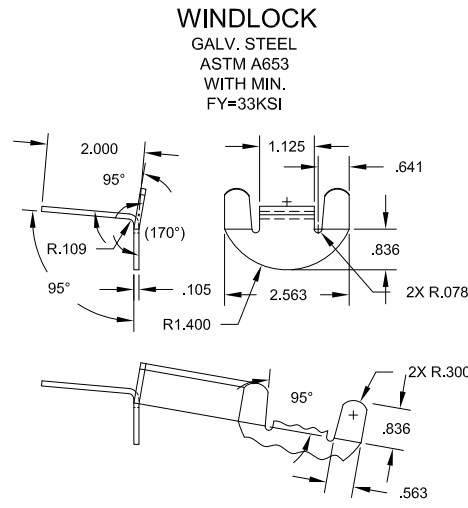

WINDLOCK
GALV. STEEL
ASTM A653
WITH MIN.
FY=33KSI

OPENING HEIGHT	VERTICAL HEADROOM	HORIZONTAL HEADROOM
THRU 7'-4"	15-1/2"	17-1/2"
OVER 7'-4" THRU 8'-8"	16"	18"
OVER 8'-8" THRU 10'-0"	17"	18-1/4"

HEADROOM REQUIRED

THESE CONFIDENTIAL DOCUMENTS SUBMITTED BY JANUS CONTAIN INFORMATION OF A PROPRIETARY NATURE AND MAY NOT BE REPRODUCED OR USED TO MANUFACTURE ANYTHING IN PART OR IN WHOLE FOR ANY PURPOSE OTHER THAN THAT WHICH IS NECESSARY FOR PREPARATION OF BIDS OF ENGINEERING WITHOUT THE EXPRESS PERMISSION OF JANUS WHICH MAY RECALL DOCUMENTS AT ANY TIME.

UNLESS OTHERWISE SPECIFIED DIMENSIONS ARE IN INCHES AND TOLERANCES ARE:

DECIMAL	FRACTIONS	ANGLES	HOLE DIAMETERS
.XX ±.03	± 1/16	± 0° 30'	UNDER 0.251 +.004 -.003
.XXX ±.005			0.251 to 0.500 +.006 -.003
			OVER 0.500 +.008 -.003

PART NUMBER:	
MATERIAL:	
APPLIED FINISH:	
UNIT OF MEASURE:	
APPROVALS	DATE
DRAWN: BECKY NELSON	11-14-02
CHECKED: DON MILLS	11-14-02
APPROVED: DON MILLS	11-14-02

JANUS INTERNATIONAL GROUP, LLC.
135 JANUS INTERNATIONAL BLVD. TEMPLE, GA 30179-4435
770-562-2850/Fax 770-562-2264
© 2017 Janus International Group, LLC. All Rights Reserved

CERTIFIED WIND LOAD RATED
26 GA SERIES 750 DOOR ASSEMBLY
MAX. SIZE: 10'-0" X 12'-0"

SIZE B	DRAWING NUMBER: T1003	REV: E
SCALE: NONE	SHEET: 1	OF: 2

REVISIONS			
REV	DESCRIPTION	DATE	APPROVAL
—	DRAWING RELEASE	11-14-02	DM
A	NOTE REVISIONS	4-16-04	DM
B	NOTE REVISIONS	6-17-09	CS
C	RE-TEST 9-19-13	10-24-13	CS
D	16 GA. STEEL JAMB/1.5X1.5X.072MIN BB	9-19-16	CS
E	Note: Alternate Concrete/Masonry Fasteners	09/25/17	CS

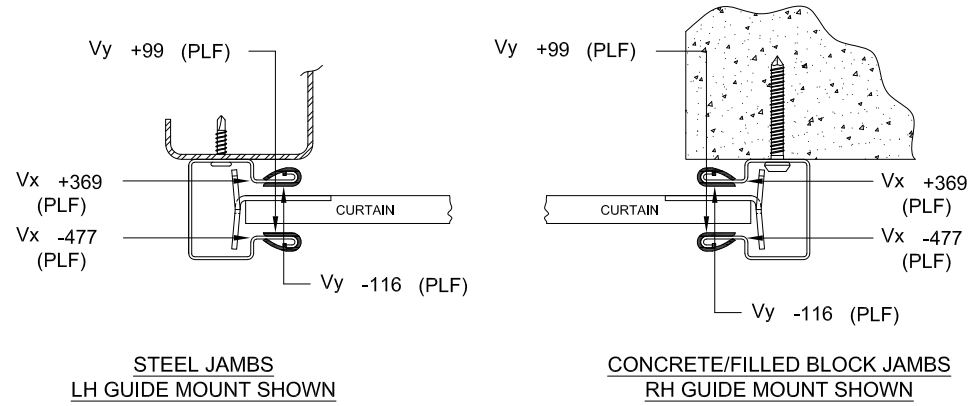
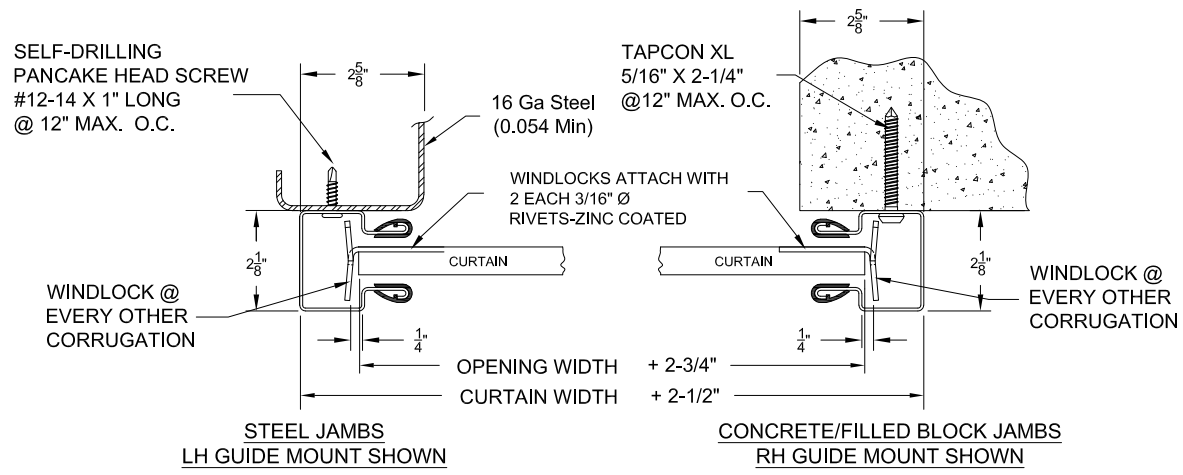

SUPERIMPOSED LOAD DIAGRAM

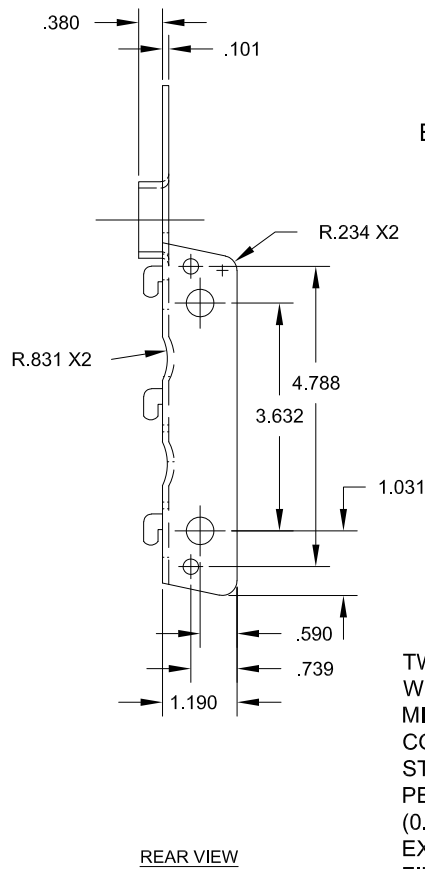

REAR VIEW

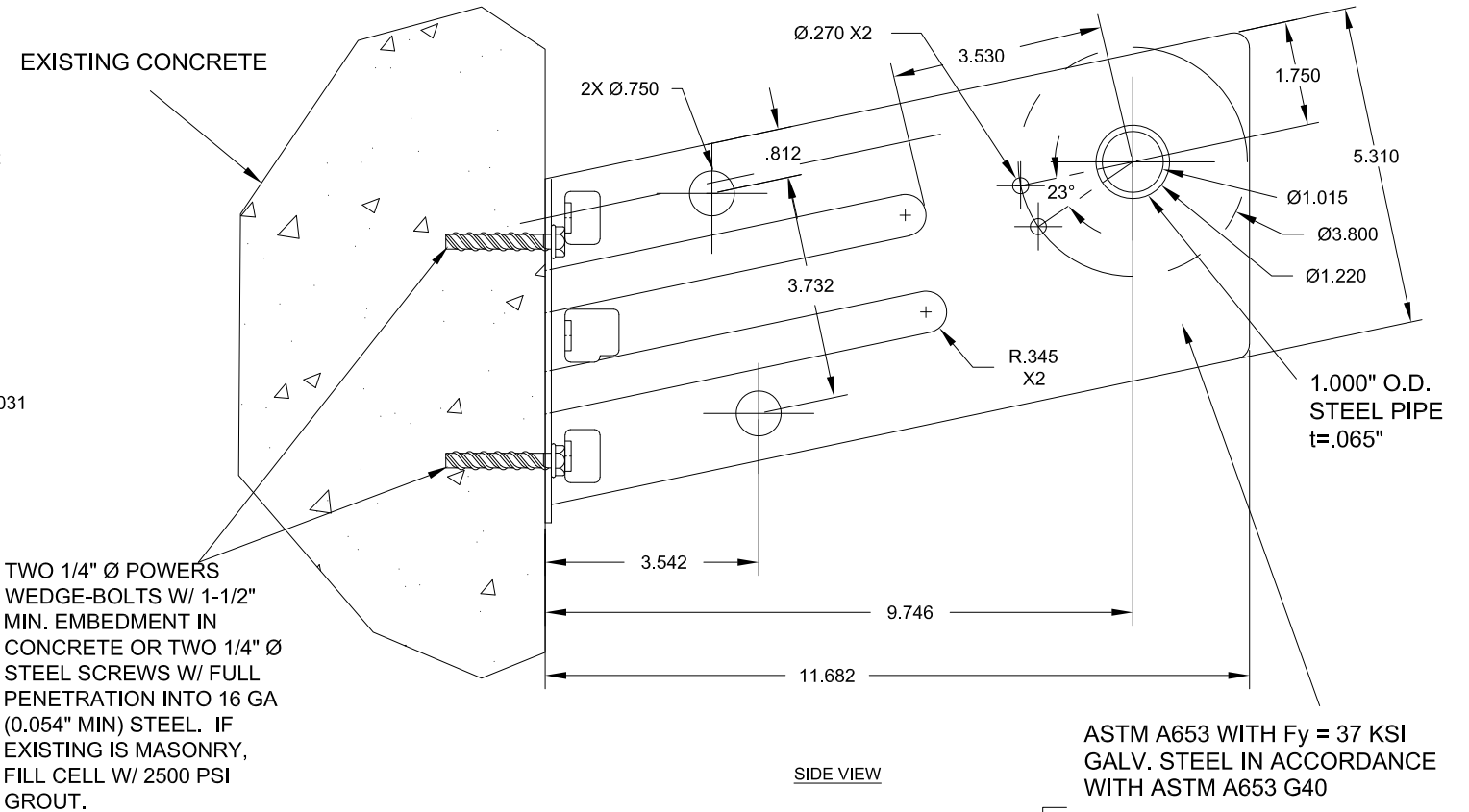

SIDE VIEW

ASTM A653 WITH $F_y = 37$ KSI GALV. STEEL IN ACCORDANCE WITH ASTM A653 G40

DOOR MOUNTING BRACKET DETAIL

GENERAL NOTES

- THIS ROLL-UP DOOR SYSTEM IS DESIGNED IN ACCORDANCE WITH THE FLORIDA BUILDING CODE.
- THIS ROLL-UP DOOR HAS BEEN TESTED IN ACCORDANCE WITH ASTM E-330 AND COMPLIES WITH ANSI/DASMA 108.
DESIGN LOAD = +19.4 PSF
-22.7
- WIND LOADS FOR BUILDING OPENINGS SHALL BE DETERMINED BY A PROFESSIONAL ENGINEER USING APPROPRIATE WIND SPEED AND DESIGN CRITERIA. THIS DOOR MAY BE USED WHERE THE DESIGN LOAD MEETS OR EXCEEDS THE DESIGN LOAD FOR THE BUILDING OPENING.
- SUPERIMPOSED LOADS ON THE JAMBS FROM THIS DOOR ARE DESIGNED AS V_x AND V_y HEREIN. CONTRACTORS SHALL HAVE BUILDING ENGINEER VERIFY ADEQUACY OF BUILDING STRUCTURE TO RESIST SUPERIMPOSED LOADS V_x , V_y , AND BRACKET LOADS SHOWN.
- ALL WELDING SHALL BE PERFORMED BY QUALIFIED WELDERS IN ACCORDANCE WITH A.W.S. SPECIFICATIONS, LATEST EDITION. ALL WELDING ELECTRODES SHALL CONFORM TO A.W.S. A5.1 GRADE E-70.
- DOORS SHALL BE PROVIDED WITH LOCK MECHANISMS AT THE OPTION OF THE OWNER.
- ALL BOLTS AND WASHERS SHALL BE GALVANIZED OR STAINLESS STEEL WITH A MINIMUM TENSILE STRENGTH OF 60 KSI.
- DESIGN BASED ON UNDERWRITERS LABORATORIES TEST REPORT NO. SV30743-20161010-REPORT4

- ANCHOR NOTES:
 - EMBEDMENT LENGTH DOES NOT INCLUDE STUCCO FINISH.
 - FOR HOLLOW MASONRY, FILL ALL CELLS @ ANCHOR WITH 2500 PSI GROUT.
 - ANCHORS SHALL BE INSTALLED IN ACCORDANCE WITH MANUFACTURER'S SPECIFICATIONS.
 - ALTERNATE FASTENERS: DEWALT SCREW BOLT+ AND SIMPSON TITEN HD.
- DOOR OPERATION TYPED TO BE PUSH-UP.
- GUIDE TO JAMB ATTACHMENT FASTENERS BEGIN 4" FROM FLOOR AND END 3-1/2" BELOW TOP OF WALL OPENING.
- TEST DOOR WALL OPENING SIZE: 10'-0" X 8'-0"

John E. Scates, P.E.
2560 King Arthur, STE 124-54
Lewisville, TX 75056
FL PE 51737_TX PE 56308/F2203

Professional Engineer's seal provided only for verification of windload construction details.

THESE CONFIDENTIAL DOCUMENTS SUBMITTED BY JANUS CONTAIN INFORMATION OF A PROPRIETARY NATURE AND MAY NOT BE REPRODUCED OR USED TO MANUFACTURE ANYTHING IN PART OR IN WHOLE FOR ANY PURPOSE OTHER THAN THAT WHICH IS NECESSARY FOR PREPARATION OF BIDS OF ENGINEERING WITHOUT THE EXPRESS PERMISSION OF JANUS WHICH MAY RECALL DOCUMENTS AT ANY TIME.		JANUS INTERNATIONAL GROUP, LLC. 135 JANUS INTERNATIONAL BLVD. TEMPLE, GA 30179-4435 770-562-2850/Fax 770-562-2264 © 2017 Janus International Group, LLC. All Rights Reserved																	
UNLESS OTHERWISE SPECIFIED DIMENSIONS ARE IN INCHES AND TOLERANCES ARE:		CERTIFIED WIND LOAD RATED 26 GA SERIES 750 DOOR ASSEMBLY MAX. SIZE: 10'-0" X 12'-0"																	
<table border="1"> <thead> <tr> <th>DECIMAL</th> <th>FRACTIONS</th> <th>ANGLES</th> <th>HOLE DIAMETERS</th> </tr> </thead> <tbody> <tr> <td>.XX ±.03</td> <td>± 1/16</td> <td>± 0° 30'</td> <td>UNDER 0.251 +.004 -.003</td> </tr> <tr> <td>.XXX ±.005</td> <td></td> <td></td> <td>0.251 to 0.500 +.006 -.003</td> </tr> <tr> <td></td> <td></td> <td></td> <td>OVER 0.500 +.008 -.003</td> </tr> </tbody> </table>	DECIMAL	FRACTIONS	ANGLES	HOLE DIAMETERS	.XX ±.03	± 1/16	± 0° 30'	UNDER 0.251 +.004 -.003	.XXX ±.005			0.251 to 0.500 +.006 -.003				OVER 0.500 +.008 -.003	PART NUMBER: MATERIAL: APPLIED FINISH: UNIT OF MEASURE: APPROVALS: _____ DATE: _____ DRAWN: BECKY NELSON 11-14-02 CHECKED: DON MILLS 11-14-02 APPROVED: DON MILLS 11-14-02	SIZE: B DRAWING NUMBER: T1003 SCALE: NONE SHEET: 2 OF: 2	REV: E
DECIMAL	FRACTIONS	ANGLES	HOLE DIAMETERS																
.XX ±.03	± 1/16	± 0° 30'	UNDER 0.251 +.004 -.003																
.XXX ±.005			0.251 to 0.500 +.006 -.003																
			OVER 0.500 +.008 -.003																

October 2, 2017

Janus International
Curtis Schroeder
135 Janus International Blvd
Temple, GA 30179

Re: Janus Models 750 and 1100 Rolling Doors

To Whom It May Concern:

At the request of Janus International, I have reviewed the drawings and tests listed below. The tests were conducted by Underwriters Laboratories according to ANSI/DASMA 108 and ASTM E-330 test procedures. Testing complied with DASMA 108-05, 108-2012 and E330-02. The pressure listed on the drawings are the direct result of these tests or conservative engineering rational analysis from the actual tests. I have concluded that the construction shown on these drawings comply with the structural requirements of the 6th Edition (2017) Florida Building Code. I certify that I meet the requirements of "independence" as detailed in Florida Statutes.

Drawings

T1000-RevE	Model 750 Rolling Curtain Door up to 3'-0" wide,	+35.0 / -45.0 PSF
T1001-RevE	Model 750 Rolling Curtain Door up to 6'-0" wide,	+19.9 / -24.4 PSF
T1002-RevE	Model 750 Rolling Curtain Door up to 8'-8" wide,	+24.4 / -27.0 PSF
T1003-RevE	Model 750 Rolling Curtain Door up to 10'-0" wide,	+19.4 / -22.7 PSF
T1012-RevC	Model 1100 Rolling Curtain Door up to 8'-8" wide,	+24.4 / -27.0 PSF
T1013-RevC	Model 1100 Rolling Curtain Door up to 10'-0" wide,	+19.4 / -22.7 PSF

Test Report

Test Reports

<u>Drawing</u>	<u>UL Test Report</u>	<u>Test Date</u>
T1000-RevE	SV30743-20161010-Report 1	09-26-2016
T1001-RevE	SV30743-20161010-Report 2	09-26-2016
T1002-RevE, T1012-RevC	SV30743-20161010-Report 3	09-26-2016
T1003-RevE, T1013-RevC	SV30743-20161010-Report 4	09-26-2016

The test facility was located at:

UL LLC
750 Anthony Trail
Northbrook, IL 60062

The test reports were signed by an authorized representative of UL LLC, which is an accredited independent laboratory.

Testing was conducted in a manner that complied with DASMA 108-2012, and with ASTM E330-02.

Calculations

The loads applied to the jambs by the door via direct pressure and end-tension catenary forces were computed using industry standard methods. These results are shown as "Vx" and "Vy" on sheet 2 of each drawing. In some instances, the catenary load was zero and thus Vx does not appear on these drawings.

Installation

Anchorage Requirements:

The door drawing includes means to attach the door to Steel or Concrete building structure as detailed on Sheet 2.

This Evaluation Report does not address design of the wall/jambs themselves, but provides the anticipated jamb loads that will be generated by this product, Vx and Vy, also illustrated on Sheet 2.

Model Description

This Evaluation is for Models 750 and 1100 Rolling Doors by Janus International.

All doors consist of a corrugated steel sheet curtain suspended from a drum roller. The curtain on all models is suspended from a drum roller. Coiling around the drum raises the curtain. The sides of the curtain are constrained from lateral movement along their vertical edges by steel guides that are attached to the door jambs. This constraint provides resistance to wind forces. Various guide configurations are used for the different door styles included in this report. The wind forces are transferred from the curtain to the guides and then through the attachment elements to the door jamb.

Series 750 (Mini Door)

Door curtains have a thickness of 26 gage (min. 0.017 in.) and are made of ASTM A653 structural steel, grade 80, pre-painted, galvanized steel with a full coat of primer and baked siliconized polyester finish coat. The corrugated sheets are interlocked mechanically to form the curtain. Lap splices are at approximately 20 inches on center vertically in the installed door. The corrugation height is approximately 5/8 inches and the corrugation pitch is 3.25 inches. Style variations include door width, windlocks, and wind load rating.

Series 1100

Model 1100 is the same as the Model 750 in windload features. It is the commercial variant.

Various door widths are described in detail on drawings T1000 (3'-0" wide), T1001 (6'-0" wide), T1002/T1012 (8'-8" wide), and T1003/T1013 (10'-0" wide).

Doors 3'-0" wide are constructed according to drawing T1000.

Doors greater than 3'-0" wide up to 6'-0" wide are constructed according to drawing T1001. A chart on this drawing shows the allowable pressure ratings based on various door widths.

Doors greater than 6'-0" wide up to 12'-0" wide may be constructed per drawings T1002, T1012, T1003, and T1013. Widths not specifically listed carry the same design wind pressure as the next larger documented width provided all other requirements on the larger width door drawing remain unchanged.

Doors shown on drawings T1000 and T1001 do not have windlocks.

Doors shown on drawings T1002, T1012, T1003, and T1013 have windlocks.

Limitations

The drawings cited above are an explicit part of this evaluation report. The text of this report does not attempt to address all design details, but relies upon the illustrations and text of these drawings and instructions as well.

Each door should be chosen based on the "psf" requirement determined for a specific installation or locale.

The maximum opening width approved with this report is 10'.

The maximum door height for Model 750 is 12' nominal.

The maximum door height for Model 1100 is 14' nominal.

Doors narrower than tested width are allowed, but carry the same psf as the tested product. Exception: Drawing T1001 has a chart for widths less than tested that may be used.

The user of this product is reminded that rolling doors can generate substantial catenary forces at the jambs ("Vx"). The building jambs must be designed to withstand these loads in combinations of Vx with Vy(+), and Vx with Vy(-) shown on sheet 2 of the drawings.

These doors have not been evaluated for impact.

These doors have not been evaluated for use in the Florida High Velocity Hurricane Zone (HVHZ).

┌

┌

John E. Scates, P.E.
FL PE #51737

┌

└

The digitally-signed file is the original. Printed copies are not originals (just as copies of paper-signed documents are not originals).