



SUPERVALU Routing Guide 2014

These instructions provide key information on our requirements for distribution and transportation to all SUPERVALU distribution center locations, supersede all previously issued instructions and will continue in effect until cancelled or modified in writing by SUPERVALU Inc.

The purpose of this routing guide is to clarify SUPERVALU's receiving performance expectations to our vendors for the delivery and condition of product sent to all of our distribution centers. It is our intent to work with our vendors to increase joint efficiencies and eliminate unproductive or costly activities. When this outcome is not achieved, noncompliance fines may occur. The SUPERVALU Vendor Compliance policy and violation/fine list is available on SVHarbor.

PRODUCT QUALITY AND PACKING REQUIREMENTS

All packaging must meet standards set by SUPERVALU Inc.

- Packaging must conform to the freight carrier's requirements and be able to withstand the normal hazards of transportation.
- Packaging must withstand normal warehouse storage conditions.
- All corner boards must be 100% cardboard on any load to any SUPERVALU facility.
- All product purchased by SUPERVALU must be delivered with sufficient shelf life to allow for normal distribution and retail activities to occur in selling that product at retail.
- Sanitation/condition of carrier's equipment is key to quality/condition of the delivered product. All delivering equipment and product must be free of rodent or insect infestation and general debris.
- Perishable and frozen product must be delivered at proper temperature stated on bill of lading.
- Backordered product that is on backorder at time of shipment will become the sole responsibility of the supplier. The supplier must contact the buyer for pre-approval of shipping backordered product.
- Due to arrive: Each SUPERVALU purchase order has an expected delivery date designated on it. This "deliver date" is the appropriate date product should arrive at the designated SUPERVALU Distribution Center and/or store. This date should be indicated

on each of the Bills of Lading and instruct the carrier to indicate this due date on its freight bill.

MARKING REQUIREMENTS

Easy identification of your items upon their arrival at SUPERVALU's delivery location is very important to the receiving and distribution of your product. Below please find a list of the types of carton marking that enable our dock workers to expedite the receiving process. Shipping cartons must be identified with some or all of the following information:

- Complete Item Description Including Pack and Size
- Easily Readable "Sell by Date", "Use by Date" or "Pack Date"
- Case Pack
- UPC Code or Vendor Item Code Number
- Precautionary markings such as "Glass", "Fragile", "Handle with Care", etc.
- Net weight in pounds and open coded "sell by", "use by" or "pack dates" must be prominently displayed on each shipping carton
- Sell by date markings for open coded merchandise must be consistent on both the inside and outside of the shipping carton. Note: "Sell by Date" information must be easily readable by dock personnel, and must include the words "sell by date", "use by date" or "pack date".

All exterior product packaging markings for product dating must be consistent with the dating on the retail selling unit.

Mandatory Country of Origin labeling "COOL" requirements

All shipments into all SUPERVALU Distribution Centers and Stores must comply with COOL requirements.

SHIPPING REQUIREMENTS

BILL OF LADING

Two copies of bill of lading/packing slip containing an itemized list of all merchandise shipped must be included with each shipment and must include the following information:

- SUPERVALU's Purchase Order Number
- UPC Code or Vendor Item Code
- Quantity Shipped by Item.
- Net Weight
- Sell by Dates
- For temp controlled loads must be listed on the bill of lading
- Country of Origin information must be provided on all current invoices. The origin information must be listed by line item.

The following must appear in the body of the Bill of Lading as an addition to any other information specified within the instructions found elsewhere in this guide.

- SUPERVALU's Purchase Order Number
- Number of cartons shipped
- Delivery appointment required
- Driver Signature
- Carrier Name
- Shipper Number or Load Number
- Pick-up Date
- Seal Number
- Piece count or Pallet count (as applicable)
- Country of Origin Label information must be provided on all bills of lading. The origin information must be listed by line item.

Prepaid shipments must be shipped on a prepaid/F.O.B. destination basis and will not be accepted on a collect basis.

Vendors shipping prepaid /FOB shipment must notify their carriers that all charges for the complete delivery to SUPERVALU are to be billed to the Vendor. We will not accept any carrier invoices for charges resulting from Vendor prepaid FOB destination shipments. In the event that we receive carrier invoices directly on these types of shipments we will return the invoices to the Carrier and immediately deduct all of our administrative expenses from the Vendor.

- All Shipments containing hazardous materials must comply with Department of Transportation regulations.
- All shipping documents must be certified stating that the shipment is properly packed, marked and placarded.
- In no event shall Vendor co-mingle nonhazardous and hazardous product on the same trailer.
- All products must be shipped in case quantities and case pack as specified by SUPERVALU in the Purchase Order.
- Accurate case dimensions, cube, weight must be provided to SUPERVALU and maintained on all items ordered from your company.
- Any product not ordered by SUPERVALU may be refused back to the carrier for shipment back to the shipper on a "Freight Collect" basis.
- All products must be shipped according to SUPERVALU's instructions. If instructions are to ship palletized, then products must be shipped on either CHEP, PECO, iGPS,

White Wood, rental pallets or one-way pallets meeting our current pallet specifications (GMA Grade A, 4-way, 48"x40"). See: SUPERVALU GMA Grade A Pallet Specifications. Supervalu does not participate in any pallet exchange programs at our Distribution Centers.

- Pallets must be shrink-wrapped, with no product overhanging on any side of the pallet.
- SUPERVALU does not accept slip-sheets in lieu of pallets for shipments at our Distribution Centers unless prior authorization from SUPERVALU has been obtained.



Pallet Requirements

General Description

1. 3 pieces – 1¼" x 3½" x 48"
2. 2 pieces – 5/8" x 5½" or 3½" x 40"
3. 2 pieces – 5/8" x 5½" or 3½" x 40"
4. 5 pieces – 5/8" x 3½" x 40"
5. 3 pieces – 5/8" x 3½" x 40"

Note: Lead Boards can be 3 ½" or 5 ½", but the spacing between top deck boards must not exceed 3 ½"

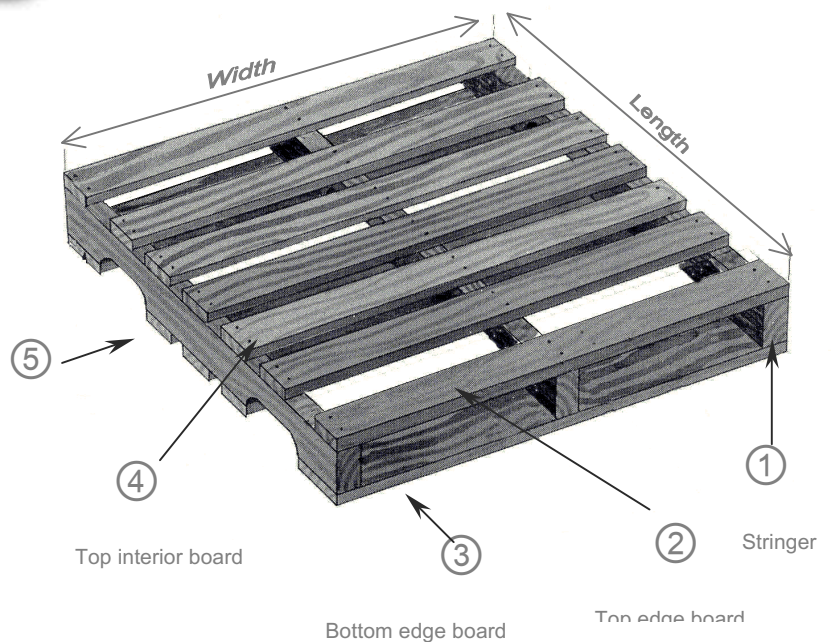

Specifications of an Acceptable Pallet

1. CHEP, IGPS, PECO or Grade A, 48"x40" wooden pallet.
2. All parts must be a minimum of the dimensions above.
3. Lead boards Flush with end of stringer.
4. All top and bottom boards must be securely attached to all stringers
5. All forms of stringer repair (double stringers, companion stringers, blocks and corrugates) are not acceptable.
6. Stringer that has a crack visible from three sides is not acceptable (Weathering cracks that are not visible from three sides of the stringer are acceptable).
7. No partial Footings. Partial footings are when ¼ or more of the stringer's width has been removed exposing securing nail shanks.
8. No missing boards or boards broken across the width on top or bottom.
9. No cracks on top or bottom boards greater than 1/8" wide and 15 inches in length.

10. No tapered breaks with a depth of greater than 1 inch along a ten-inch or more run. If at the ten inch distance the depth is less than one inch, the pallet is good. If the one-inch depth runs the entire length of the board the pallet is unacceptable.
11. No exposed splinters greater than 3 inches in length.
12. Nail heads or nail points should be hammered down into the stringer.
13. Pallets should be clean and free of contaminants.

Each item shipped to SUPERVALU must be shipped on its own pallet unless separated by layer using slip-sheets or pallets. Where possible product (single items) should not be “mixed” throughout the trailer, but should be loaded together in order to simplify the receiving process.

Additional requirements for Vendors shipping fresh produce/floral to our Distribution Centers **Routed by SUPERVALU Directly*.**

SUPERVALU requires that all products have pulp temperatures taken by the vendor with carrier present. SUPERVALU also requires that the Vendor must record the published SUPERVALU required pulp temperatures on the BOL prior to loading. The pulp temperatures taken prior to loading must conform to the published Supervalu product specifications.

Vendor will allow driver access to verify pulp temperature prior to loading. If driver is not allowed access to verify Pulp temperature Vendor must sign, on the bill of lading that driver was not allowed to verify pulp temperature prior to loading. Subsequently, if the driver is not allowed to verify pulp temperature prior to loading and the driver maintains the transit temperature range as stated on the Bill of Lading, the vendor will be responsible for any product loss or damage.

Vendor shall inform Carrier of the temperature range to be maintained on the trailer at time of carrier call to set up pickup. This will allow Carrier to pre-cool trailer to required temperature ranges prior to loading.

Vendor shall pre-cool product in the event that pulp temp falls outside of the pulp temperature requirements prior to loading.

Vendor must record the temperature range which the truck must maintain on the BOL in accordance with the Supervalu specifications. Product damage or loss resulting from incorrect temperature ranges stated on the Bill of lading will be the responsibility of the Vendor.

Vendor shall allow Carrier access to the shipping location loading area if the vendor requires the carrier to sign the BOL verifying count, Temp Tale recorder, and to verify that product was properly loaded to withstand normal transportation. In the event that carrier is not allowed access to loading area at time of loading, Vendor will not require carrier to sign BOL for count, Temp Tale recorder, or for the condition of the load. Any loss or damage caused by in-transit load shifting due to improper loading will be the Vendor’s responsibility.

SUPERVALU has chosen Sensitech (**Yellow Temp Tale 4**) to be used on all refrigerated produce/floral shipments to all of our distribution centers.

It is important at this point to outline the key elements of this program to all parties involved in the shipment of fresh produce/floral to SUPERVALU. They are as follows:

Effective with loads shipping “May 1, 2008, SUPERVALU will only remit payment for approved “Yellow TempTale 4” recorder.

TempTale recorders are required on 100% of the refrigerated loads routed by SUPERVALU.

- Driver will request a recorder from the first pick up.
- SUPERVALU will be billed \$11.00 for each TempTale recorder.
- All Temp Tales will be placed on a pallet and a tag identifying where the recorder is should be on that pallet.
- The temperature recorder serial number will be recorded on the appropriate Bill of Lading.
- All trailers should be precooled to proper temperature ranges prior to loading.
- Product temperature ranges should conform to the published SVU product specifications.
- Vendors or Carriers can request USDA inspection on any rejected products or loads due to temperature abuse.

SUPERVALU considers this program to be an essential part of our effort to provide our customers with the quality produce they have come to expect. The proper use of temperature recording devices also provides a measure of insurance against substantial losses for all parties involved: shipper, carrier and receiver.

We appreciate your cooperation in this effort. If you have any questions, please contact:
Routing.guide@supervalu.com

WHEN TO SHIP

Shipments should be tendered to carriers in such time as to assure arrival on the date set out in the SUPERVALU's Purchase Order and the specific delivery time as scheduled by your carrier with SUPERVALU's Distribution Center appointment scheduling department.

If a SUPERVALU assigned carrier does not pick-up a shipment at the appointed date and time, please contact SUPERVALU Inbound Supply Chain Regional Coordinator for the delivering Distribution Center.

See Appendix# 3 for a list of contacts

DELIVERY REQUIREMENTS

Delivery appointments are required for all shipments.

The vendor, or their carrier, will use the Dock Scheduling system or, when requested, contact the distribution center directly, a minimum of three days (72 hours) for grocery, general merchandise, frozen and dairy products, prior to the scheduled arrival date to arrange for a delivery appointment, unless otherwise agreed upon. A minimum of one day (24 hours) is required for meat, deli and direct import (dry grocery, GM and seasonal) products unless otherwise agreed upon. Product will be delivered on the requested date listed on the purchase order, unless otherwise specified by the distribution center in coordination with procurement.

Delivery appointment or delivery appointment changes must be made by the delivering carrier with the scheduling clerk at the SUPERVALU locations as listed in Appendix 2.

The carrier will be ready to unload at, or before, the scheduled appointment time. A violation will occur: 1) if the carrier fails to show for the scheduled appointment; 2) if the carrier is checked in more than 30 minutes past the scheduled appointment time; 3) if the carrier arrives with no scheduled appointment time; or 4) if the carrier fails to reschedule or cancel at least 24 hours before the appointment time.

Vendors will be held directly responsible for delivery appointments missed by any carrier on shipments where the Shipper is responsible for delivery.

Vendor's carrier may choose to unload their freight themselves or to use SUPERVALU's Unloading Service (Capstone) to offload delivery product.

LTL (Small pack) SHIPMENTS

Shipments weighing 1-250 lbs, not exceeding 10 pieces

FEDEX/UPS. The receiving Distribution Center's purchase order number must be noted on the outside of each carton and a packing list in the carton with a description and quantity of the items shipped. The shipping manifest is signed by a SUPERVALU representative for a certain number of packages, not specific items or quantities, delivered to a SUPERVALU Distribution Center. The packing slip must be included in the package at time of delivery. Supervalu has a reasonable time to verify/count and receive the goods.

Note: SUPERVALU signs for number of packages and not for individual items, and therefore this method of shipment may put your company at risk of losing product. SUPERVALU is not responsible for product not received using this method of shipment

Shipments weighing 1-250 lbs, not exceeding 10 pieces not requiring expedited service are to be shipped via UPS or FedEx.

CONVENTIONAL LTL SHIPMENTS:

Shipments weighing between 250 lbs. and 7,500 lbs or up to 750 cubic feet.

All shipments having the same destination on the same day must be combined and shipped on a single bill of lading, at the same price bracket, including shipments consigned to a freight consolidator.

Supervalu contracts with the following LTL providers for both National and Regional freight:

Old Dominion

FedEx

New England Motor Freight (Eastern Region Only/VA, PA, WV SUPERVALU locations)

Shipments weighing (between 250 lbs. and 7,500 lbs or 750 cubic feet) that pick up and deliver within the Continental U.S. are to be shipped via Old Dominion, FedEx or New England Motor Freight.

For shipments larger than 7,500 lbs but not a truck load, please contact SUPERVALU via rates@supervalu.com on how to ship the freight.

SUPERVALU recommends using one of our LTL carriers for managing your LTL shipments being delivered to one of SUPERVALU's Distribution Centers. SUPERVALU has a special drop program set up with these LTL carriers that expedites unloading while saving your company unloading costs. Please note some of our DC's have moved LTL receiving times to overnight which can add an after hour's delivery fee or cause your carrier to give your freight to a local cartage company to make the final mile delivery at an additional fee.

By utilizing one of SUPERVALU's LTL core carriers, your company will not be charged appointment fine violations.

Contact Stan Friend at Transaver, Supervalu@Transaver.com, if you find by using our core LTL providers your freight costs, including sort and segregate, are higher, and he will get a representative from our core LTL carriers to contact your office to negotiate a better on going freight rate for delivering into SUPERVALU's Distribution Centers.

If you are a SUPERVALU Supplier and have an F.O.B. or prepaid shipment that qualifies for an LTL non refrigerated cartage, log on to www.fedex.com/us/freight, for FedEx, <http://www.odfl.com> for Old Dominion, and www.nemf.com/ for New England Motor Freight to locate the nearest center or call Customer.

For routing guide questions please contact Routing_guide@supervalu.com.