

ONE-WAY VENT

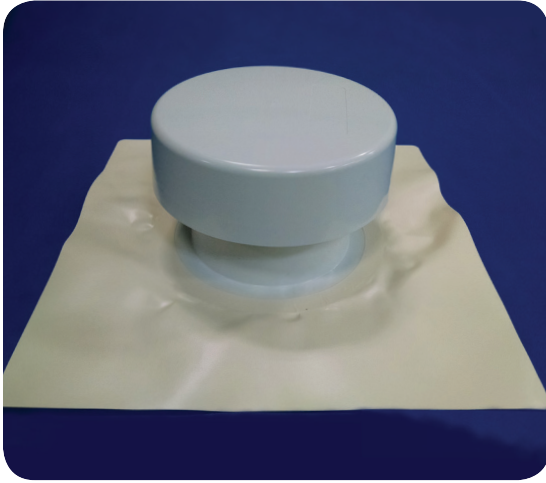

FiberTite Large Pre-Flashed One Way Roof Vent

Product Data

The FiberTite pre-flashed one way roof vent features a large capacity Marathon premium PVC vent with a pre-welded flashing for installation efficiency.

DESCRIPTION

Large one way roof vents are required on all FiberTite Roofing Systems installed over "non-vented" cellular lightweight insulating concrete roof decks. Typical installation shall utilize one vent per 1,500 square feet of roof area.

INSTALLATION:

1. Core the LWIC to the deck with a hole diameter no greater than 9-in.
2. Set the vent in a bead of FTR 101 sealant.
3. Weld the perimeter flashing sheet.

FEATURES

- One Way Venting
- Heavy Duty, UV stable PVC construction for durability
- Exclusive one-way valve to prevent moisture from re-entering the roof system
- Special insect resistant wire screen
- Permanently attached vandal proof cap
- No fastening required
- Pre-welded FiberTite membrane flashing

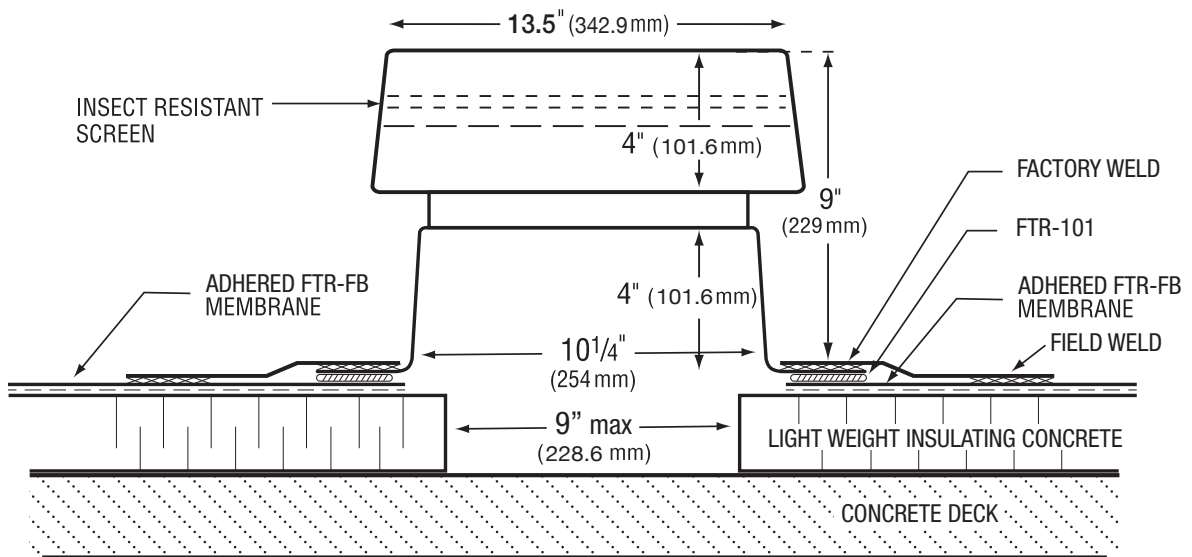

For more information on FiberTite Systems and accessories please call:
Seaman Corporation (800) 927-8578
International (330) 262-1111
www.fibertite.com

FiberTite® is a registered trademark of Seaman Corporation.

