

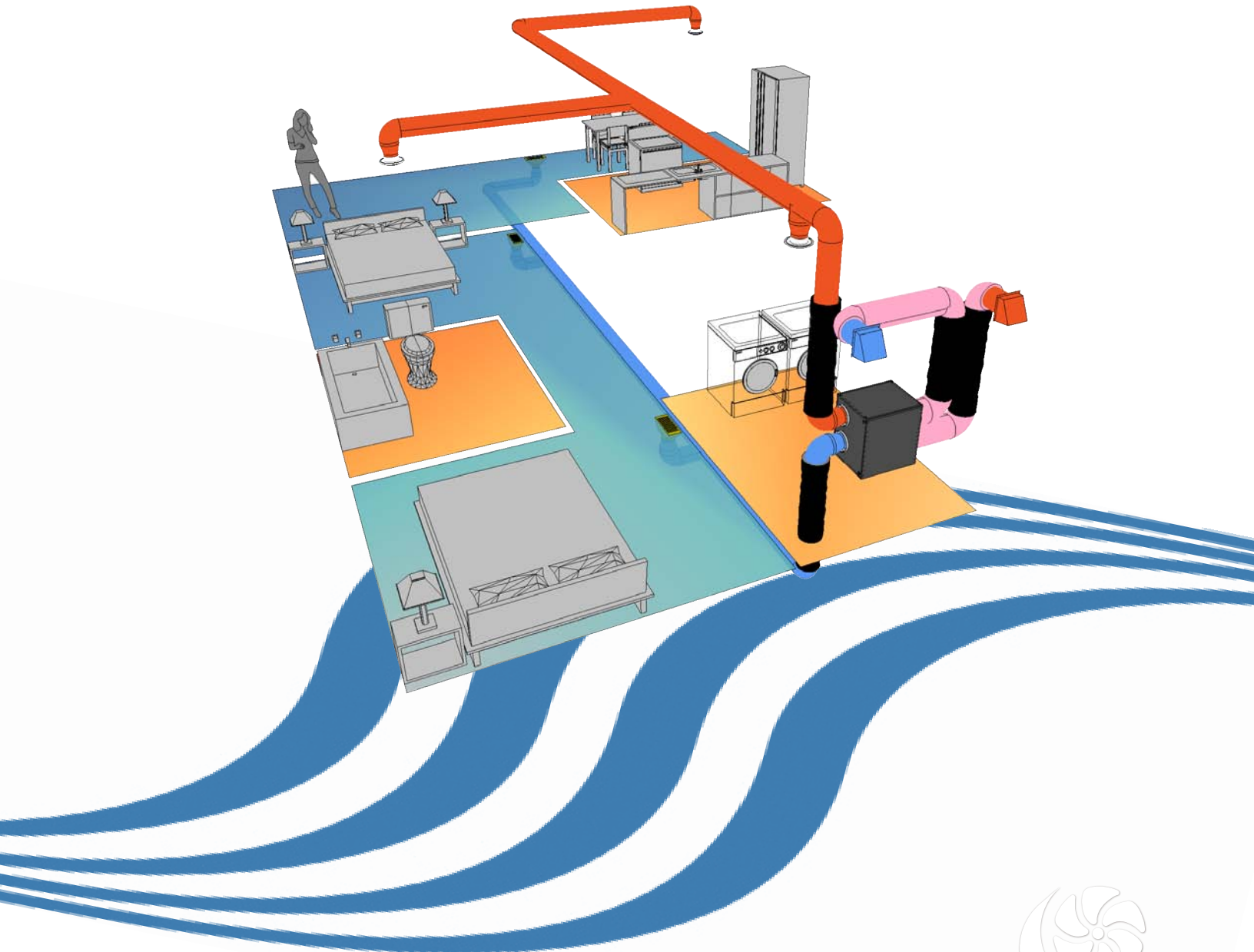

UltimateAir

Energy Efficient Ventilation

Model 200DX ERV Manual & Installation Guide



     UltimateAir
RecoupAerator



800.535.3448

www.UltimateAir.com

info@ultimateair.com

Introduction

Thank you for your purchase of the most advanced air filtration and energy recovery ventilation available. The RecoupAerator is designed to bring fresh filtered air indoors while simultaneously exhausting stale air.

The RecoupAerator 200DX is an Energy Recovery Ventilator (ERV), meaning this machine captures temperature and a portion of the moisture from the stale, outgoing air and transfers it to the incoming Fresh Air. No matter what the season, you will be comfortable breathing fresh clean air.

In addition to having an energy transfer rating of 98% ASE, the RecoupAerator moderates indoor humidity in the winter and turns away outdoor humidity in the summer.

- 98%+ heat recovery efficiency
- Exceeds ASHRAE 62.2 ventilation recommendations
- Variable blower speed with Quiet operation
- Automatic frost prevention down to 10° F
- No Condensation drain necessary
- 2-year Warranty with Extended Available
- 3 Brushless EC motors with Permanently lubricated Ball Bearings
- EconoCool™ (brings in cool, filtered night air in summer)
- Filtration 95% at 1.8 microns (MERV 12)
- Up to 75% moisture transfer capability (depending on season)
- Optional Pressure Transmitter adjusts for changes in indoor air pressure
- Optional CO₂Guard™ senses and adjusts for elevated CO₂
- Compatible with many IAQ monitors and fans
- Low/easy maintenance
- Filter service indicator
- Fully insulated

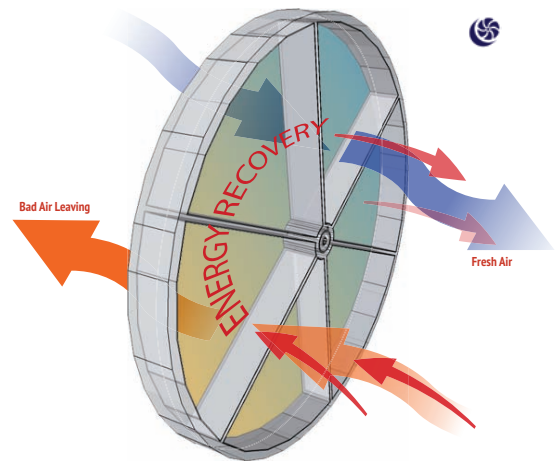

Specifications

Model	RecoupAerator 200DX (ERV). Includes pre-filters, patented energy transfer/filtration material, fans, control, and motors.
Airflow Capacity	~30– 200CFM
Apparent Sensible Effectiveness (ASE)	98%... Testing In Accordance with CAN/CSA-C439
Heat Exchange Type	Patented rotary random matrix polymer
Filtration	Filtration material 95% effective at 1.8 microns (MERV 12), replaceable, with separate washable aluminum pre-filter
Electrical Ratings	120 VAC, 60 Hz., 6.0 amp (start up)
Fuse (low voltage)	¼ Amp, 250V 3AG slow blow fuse
Dimensions	25 in. H x 19 in. W x 25 in. D (63.5 cm H x 48.25 cm W x 63.5 cm D)
Unit Weight	72 lb (32 kg)
Shipping Weight	80 lb (36 kg)
Mounting	May be mounted by vertically, horizontally, suspended from floor joists, placed on floor or shelf in conditioned spaces. Collars (four) are double collar 6” & 8” in diameter.
Maintenance	Check Filters/Wheel every 6 months.
Application	<p>The 200DX is an Energy Recovery Ventilator (ERV), meaning that the RecoupAerator captures temperature and moisture from the stale, outgoing air and transfers it to the incoming air stream.</p> <p>The RecoupAerator is equipped with a variable blower speed control, “check filter” indicator light, auxiliary IAQ control inputs.</p>
Controls	These controls allow you to adjust the airflow as needed to maintain a comfortable level of fresh air. The “check filter” indicator light is designed to let you know when to clean or replace the energy transfer wheel material.
Frost Control	Programmed to regulate heat exchange automatically to prevent frost build-up down to approximately 10° F. During this mode, the Wall Dials green light will be flashing. Electric or Geo-thermal Preheating Available as a frost control option.

Performance Data

UltimateAir 200DX		Tested CAN/CSA-C439-09		
	Supply Temperature °F	Net Airflow CFM	Sensible Recovery Efficiency	Apparent Sensible Effectiveness
HEATING	32	155	83	96
	39.2	155	82	98
	17.6	131	84	96
COOLING	95	146	36 TRE	75

Fan

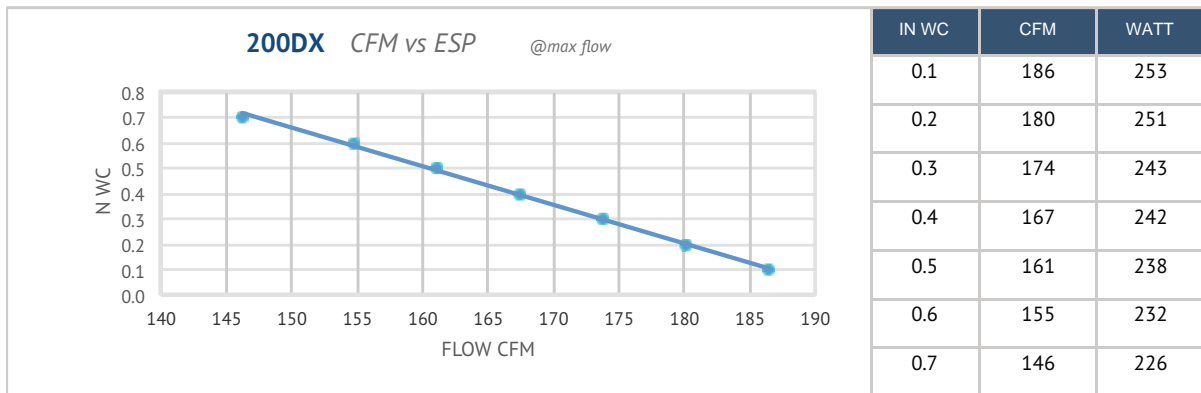

Power The power curve was generated using the average airflow rate over all four ducts.

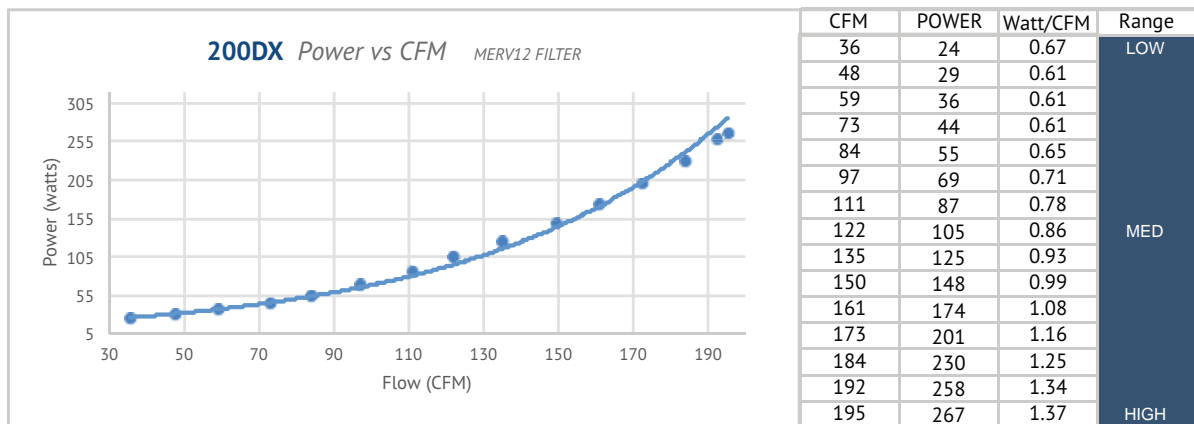

Note: Curves are generated from actual test data and should only be used as general guidelines. Actual results may vary.

Installation & Ducting

We strongly recommend a licensed HVAC technician install this product, because of complex considerations such as airflow dynamics and condensation issues. Read these instructions carefully before beginning any installation procedure. Failure to follow them closely may reduce ventilation effectiveness, cause a hazardous condition, and/or invalidate your warranty. Installation by non-licensed HVAC personnel may void the warranty.

Unpack the 200DX and check to be sure the following are packaged inside the machine and undamaged:

- Four (4) starter collars.
- Wall mountable flow control dial (pre-wired for test run).
- Literature package with this manual, and warranty registration card.

When installing:

1. **Test Run the RecoupAerator by plugging into a power outlet and adjust the blower speed with the included Wall Dial.** Familiarize yourself with the intake and outlet duct configuration and installation dimensions. Decide how you will mount the unit. We recommend ACCA's manuals D & J for proper load calculations and duct sizing.

After installation is complete, fill in contractor's name and phone number on the last page of this manual, and please **complete the Warranty Registration** to validate the installation.

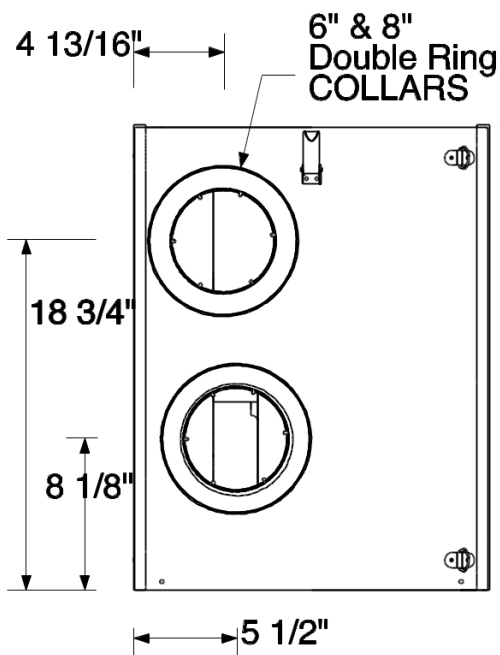
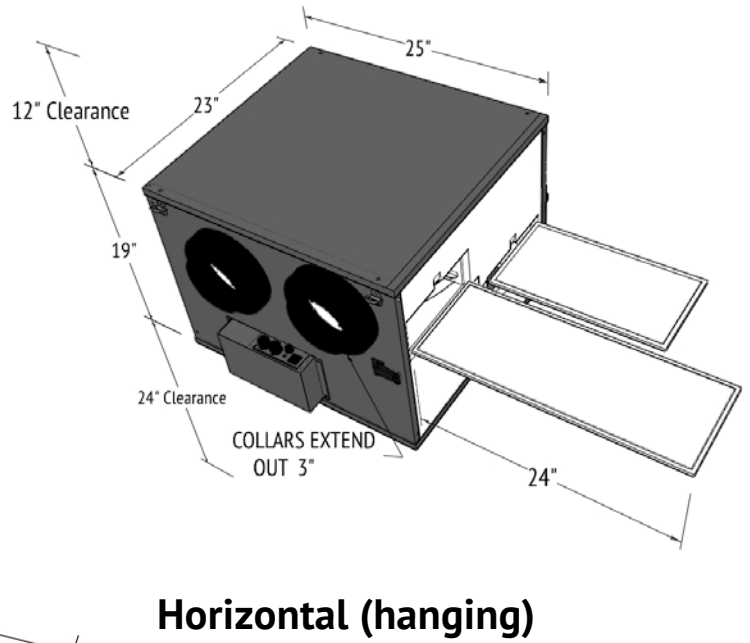
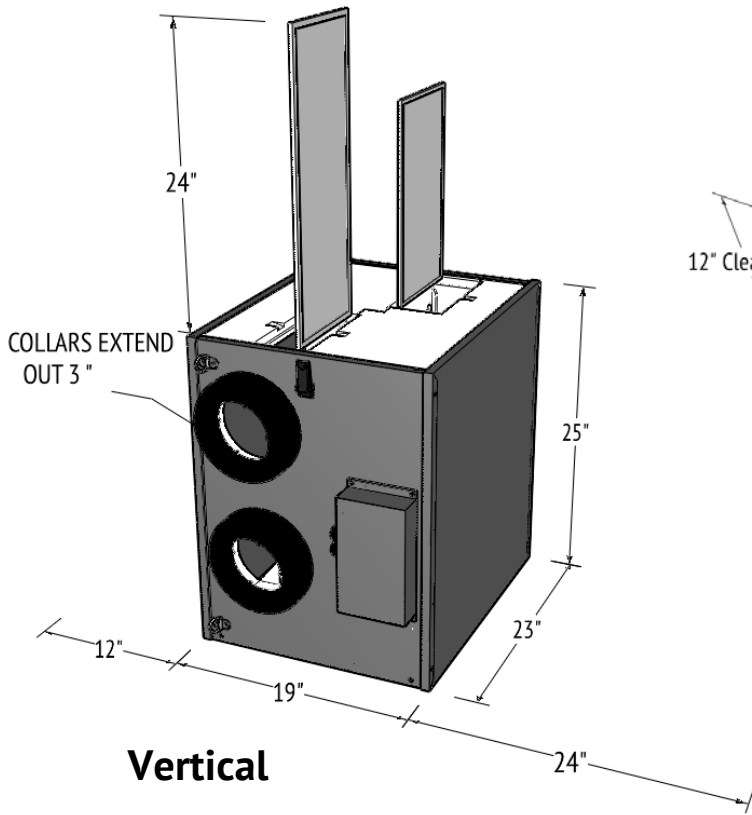

Duct to Indoors

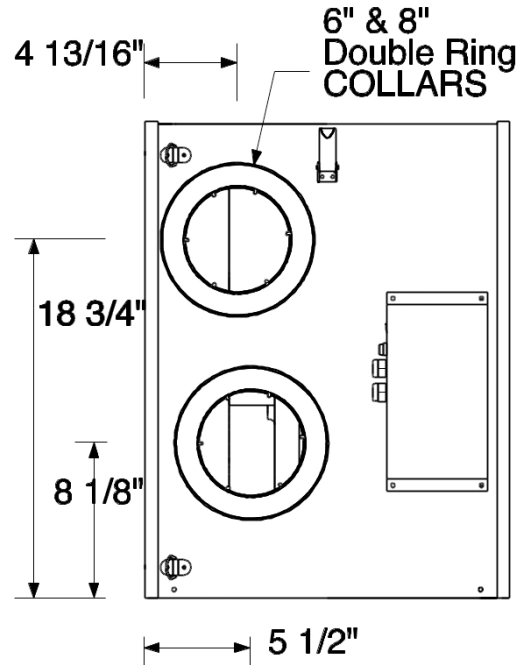

Duct To Outdoors

CAUTION

Always Disconnect the Power supply before wiring to prevent electrical shock and/or equipment damage.



*The RecoupAerator is equipped with a **three-pronged grounding plug for your** protection against shock hazards and should be plugged directly into **a properly grounded, 120V, three-pronged** wall receptacle. If only a two-pronged outlet is available, it must be replaced with a properly grounded three-pronged receptacle in accordance with the National Electrical Code and local codes and ordinances. A qualified electrician should do this work. Use proper circuit protection. If you have any doubts about the grounding in your house, contact a qualified electrician.*

Option 1: Dedicated Ventilation Ducting

The most complete installation option and ideal for new construction. Use option 1 when a home or business is concerned with health issues (e.g., when an occupant has asthma or severe allergies). Option 1 is the only option for buildings without existing forced air ductwork. Option 1 is also used with radiant heat flooring or geothermal heating.

The more rooms to which ductwork is run the more effective the system will be. Dedicated ductwork is installed for the stale air exhaust and the fresh air delivery. The kitchen, laundry room, and other areas with high contamination should contain registers for the exhaust. Areas such as the living room and bedrooms should receive the full benefit of the fresh air being brought in, and a good installation will feature supply vents in these locations. As a general note, fresh air is generally supplied at floor level, and stale air is removed at ceiling level. A simpler but somewhat less effective version of this system uses one exhaust and one or more delivery registers located strategically to encourage circulation throughout the house.

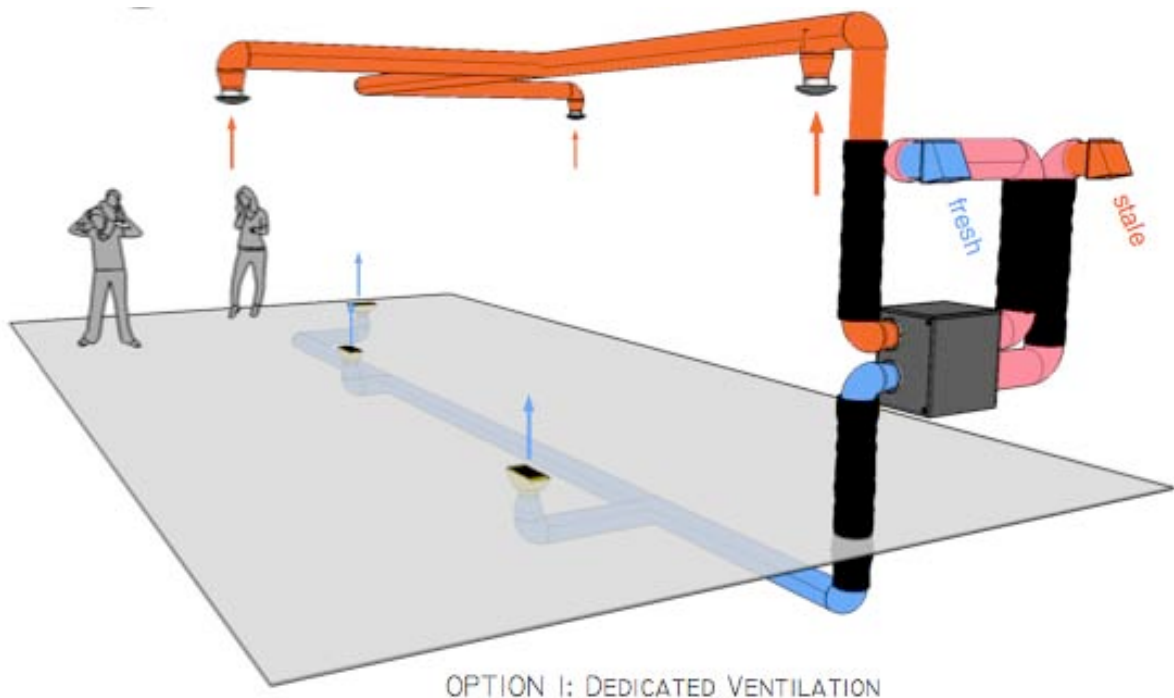

Option 2: Shared Forced Air Supply, Dedicated Stale-Return

This method partially uses the existing HVAC duct system. Fresh Air IN from the RecoupAerator® gets ducted into the cold air return side, or supply side of the furnace. Stale Air Out thru the RecoupAerator® is ducted separately to points throughout the house from which you would like to remove stale air (e.g., the kitchen, bathroom, open stairwell). This method allows for independent control between the HVAC air handler and the RecoupAerator® (i.e., the air handler and the RecoupAerator® are not interlocked and run independent of each other).

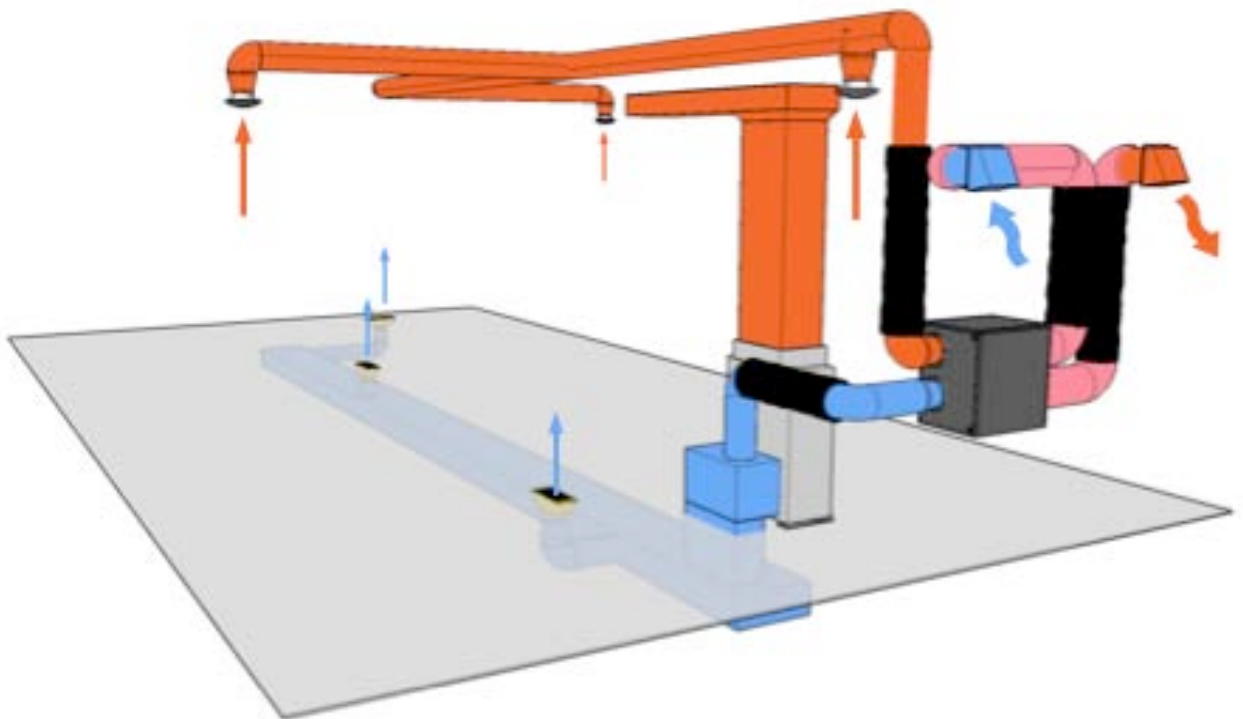

OPTION 2: SHARED FORCED AIR SUPPLY, DEDICATED RETURN

Option 3: Shared Forced Air Supply, Shared Return

This method uses the existing HVAC duct system completely.

Fresh Air IN from the RecoupAerator® is ducted to the main supply duct to the house. The Stale Air Out thru the RecoupAerator® is ducted into the cold air return duct of the furnace. If you use this method, we recommend that you wire your RecoupAerator® and your air handler to run simultaneously (i.e., they will be interlocked) to prevent recirculation shorting thru back past the furnace air handler.

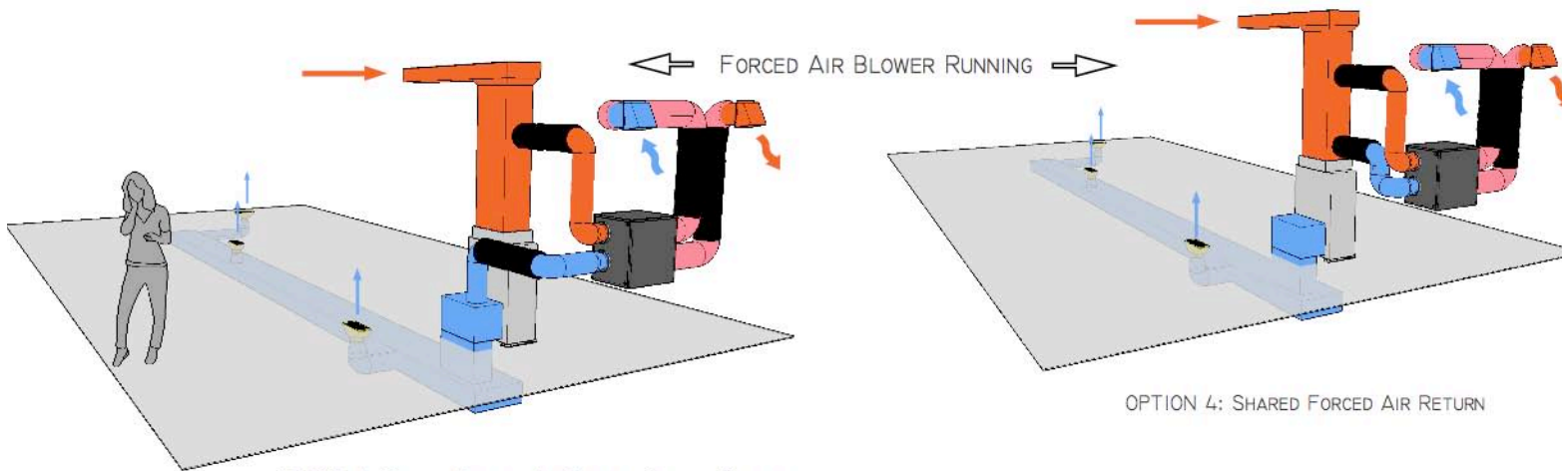

Option 4: Shared Forced Air Return

This method uses the existing HVAC duct system completely. Both the Stale Air Out and the Fresh Air IN from your RecoupAerator® are attached to the cold air return duct of your HVAC system. Be sure to keep at least three feet of space along the cold air return duct between the two RecoupAerator ducts. When using this method, your RecoupAerator® and your air handler must be wired to run simultaneously (i.e., they are interlocked).

Positioning the 200DX

Position the RecoupAerator in a location convenient to existing ducting and furnace/forced air system. We do not recommend the RecoupAerator be mounted in an unconditioned space, as this will affect the performance and longevity of the unit. If possible, locate equipment away from the quiet rooms (e.g., bedrooms). Avoid directly suspending the RecoupAerator from the mid-span area of joists. This can result in structural vibration. Allow adequate space for maintenance and service of the RecoupAerator.

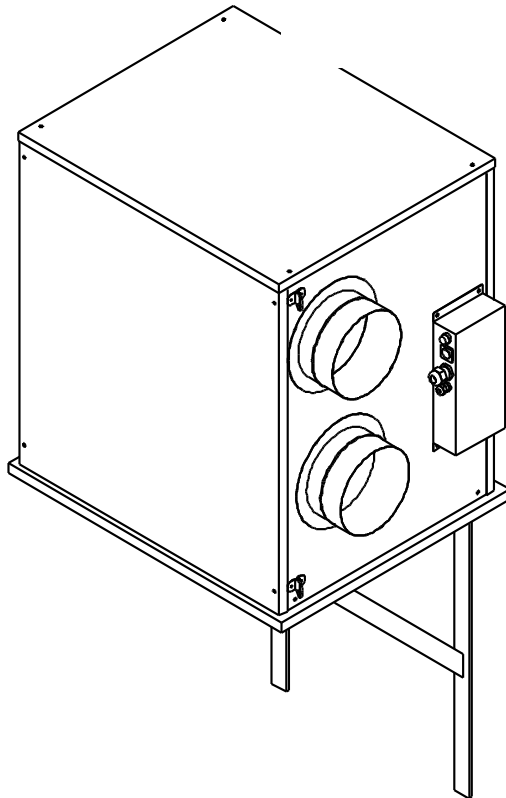

Vertical Floor Mount. The RecoupAerator rests on four rubber feet when mounted vertically. Set the machine on a flat, dry, level surface at least 20" x 24" which is able to support a minimum of 85 lbs. Allow 24" above for removal of the top cover and pre-filters so they may be easily lifted away for service of the heat recovery/filtration material. Allow 24" on the front side of the unit for service and cleaning.

Horizontal. Use a Ceiling Mounting Kit to suspend the RecoupAerator from the “D” rings located on the four corners. Allow adequate space (12”) between the ceiling and the unit to allow for servicing. Allow 24” below the unit for servicing. Allow 24” on the filter access side of the unit.

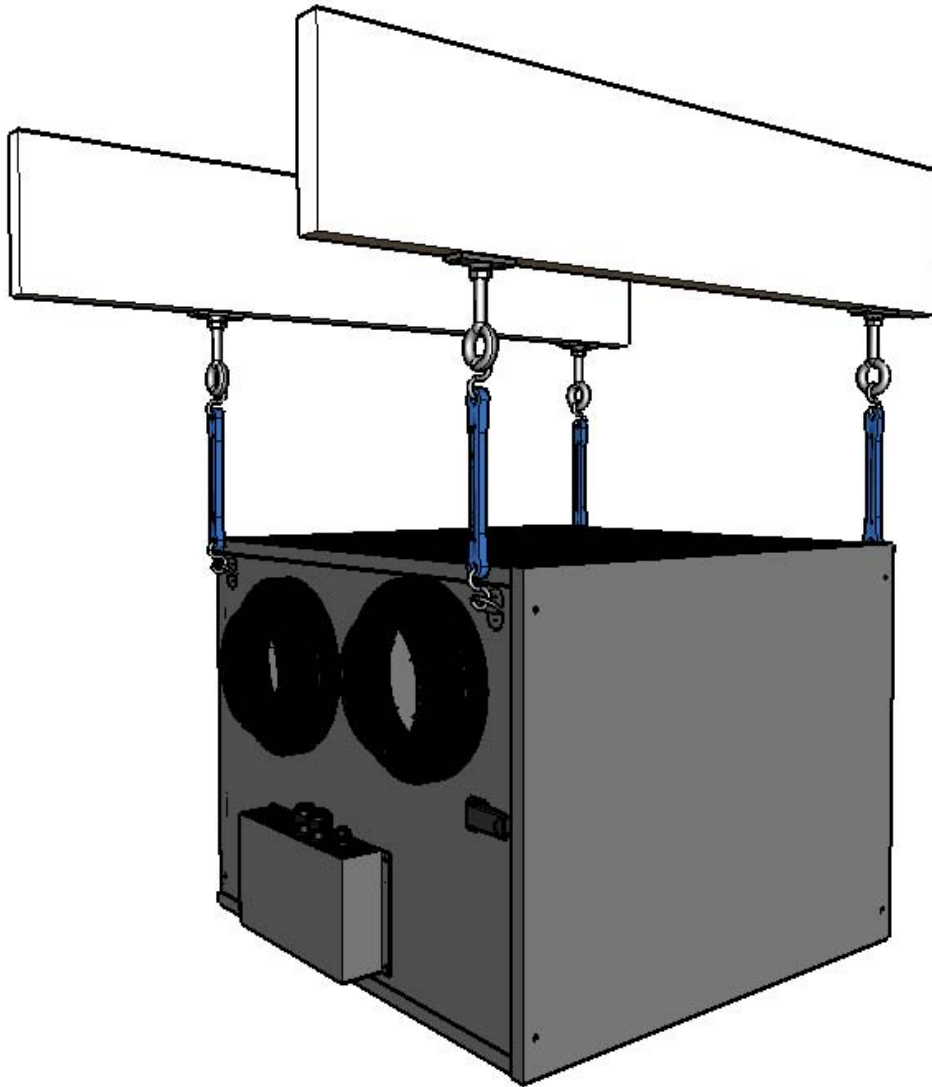

Planning the Duct Work

Ducting between the RecoupAerator and the outdoors must be insulated and sealed with a vapor barrier to prevent 'sweating'.

Locate all four collars and attach to the unit at each of the 6" duct holes. Peel the backing from the double-sided tape on the collars and then attach them to the unit with three self-drilling screws each (provided).

Two duct holes are labeled Connect to Outside. The other two duct holes are labeled Connect to Inside.

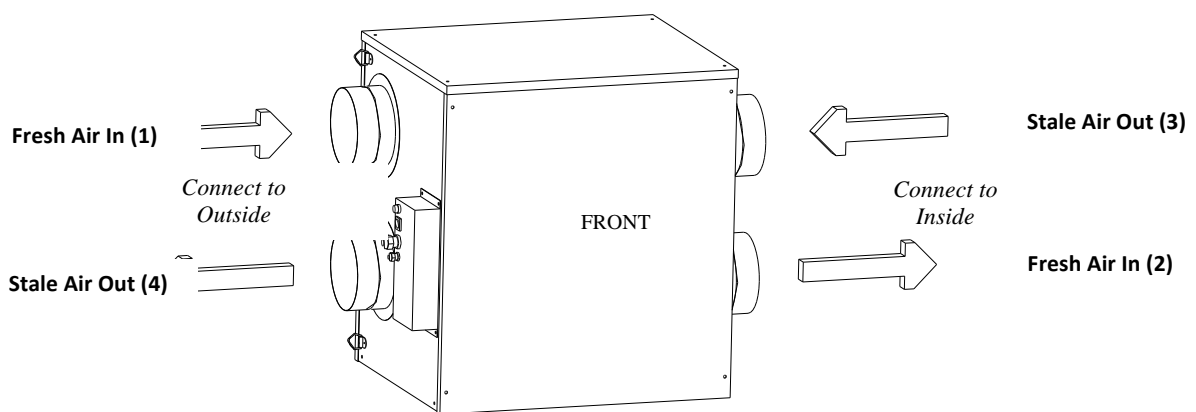

To ensure maximum airflow, use the largest practical duct for the installation. Design and installation of ductwork must be in accordance with HVAC standards and regulations to allow required quantities of fresh air to circulate through the building. Under no circumstances should the trunk duct size be less than six inches, as this will restrict the airflow considerably. Insulated flex ducts tend to reduce air noise levels but add airflow resistance, and galvanized ducts provide the least resistance to airflow, but may amplify noise. Duct connections inside each building will vary. The outside duct connections are the same for most installations and must be insulated.

General Ducting Guidelines

The duct installation should follow the following standards:

- a. **Mechanical integrity** The system will remain as built for the life of the building, without developing leaks, obstructions, or insulation failures.
- b. **Freedom from leaks** All air moved by the air handler will be drawn from and delivered to the intended conditioned spaces.
- c. **Proper insulation** Conditioned air should Not exchange heat with Unconditioned spaces.

A licensed HVAC contractor should do the duct design calculations. To minimize backpressure: Make the intake and exhaust duct runs as short and straight as possible. Use 45-degree elbows instead of 90-degree where practical. Where flex duct is used, make sure that no "crimping" or "collapsing" of the duct occurs. Stretch flex duct evenly to avoid air restriction. Use "Y" connections instead of "T" connections wherever possible. Size ductwork according to recognized industry standards such as Manuals D and J, published by the Air Conditioning Contractors of America (ACCA).

- Use the minimum length of flexible duct possible
- Minimize any noise transmission through the ducts by using a short run (2-3 ft) of insulated flex duct on duct trunks coming from the unit and going to the inside of the house.
- Position outdoor fresh air intakes away from known sources of pollution. A six-foot separation is the recommended distance between the Fresh air intake and stale air exhaust. Locate Intake and Exhaust 40 inches from the corner of the building, and above the projected snow plane.
- Position inside grill/register vents so that fresh air does not blow directly onto occupants or the thermostat.
- Fasten joints between duct components with screws, sealant, and/or rivets and wrap them with metal foil duct tape to ensure no leaks.

Making a Noisy Duct System Quiet

1. Run at the lowest flow setting necessary for fresh air requirements.
2. When installing the unit, allow for a three-foot section of insulated flexible duct to go from the starting collar on the unit to the rest of the ductwork (on all four collars).
3. Locate the unit farther away from the source of the noise pollution area (if the unit is close to a living room vent where the noise is too loud) This will allow the noise to dissipate in the longer duct length.

Tools to install non-metallic flexible duct:

Knife or Scissors/Wire Cutter: Use knife or scissors to cut duct wall. Use wire cutters to cut the spiral wire helix.

Foil Tape: Use only tapes that have been listed and labeled to Standard UL 181B and labeled "181B-FX". Use two wraps of 1½" minimum width.

Draw Band/Plastic Clamp/Clamp Tool: Use for low-pressure systems up to four-inch wg (diameters of three to 10") and up to two-inch wg (diameters of 12" and over). To achieve proper tensioning of clamp, set clamp to max tension setting.

- Support hardware (e.g., couplings, and fittings) independently of flexible duct using elbows or other devices.
- Repair damaged vapor barrier jacket. If internal core is penetrated, replace or splice flexible duct.
- Install duct fully extended along straightest path possible.
- Flexible duct shall be supported at manufacturer's recommended intervals, but at no greater distance than five feet, and the maximum permissible sag is ½" per foot of spacing between supports.
- In no case will the hanger or saddle material supporting the flexible duct be less than 1½" wide.

Flexible Duct

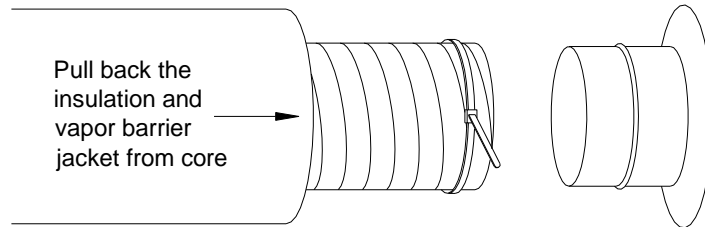

Apply mastic over the fitting and / or inside the duct core before pulling the inner lining at least 1-inch over the fitting.

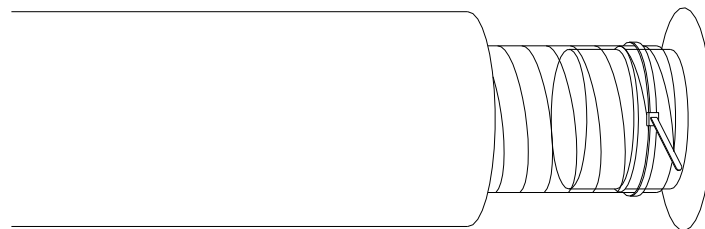

Secure the inner core to the fitting using a draw band or three wraps of pressure-sensitive tape - apply additional mastic over the connection.

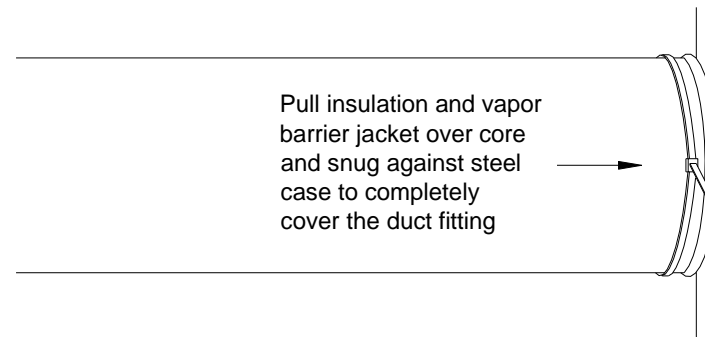

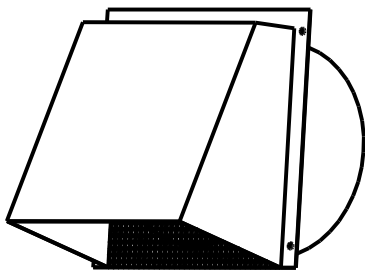

6' MINIMUM RECOMMENDED
SEPERATION

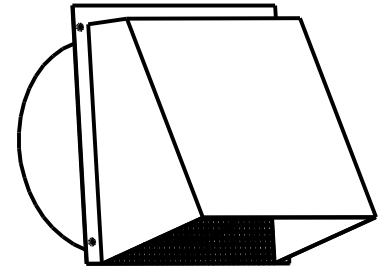

Ducting to Outside

Note: The ducts to the outside must be insulated. The collars labeled “to Outside” must be ducted through the exterior of the building, and the following precautions should be taken.

1. The ends of the two ducts should be as far apart as practical (at least six feet, either horizontally or vertically) to minimize re-circulation of the exhaust air.
2. Terminate the ducts using exterior weather hoods. Ensure that the exterior weather caps have wire mesh to keep out birds and debris. Angle the weather caps down and away from each other and place them away from exhaust vents for other appliances such as dryers or hot water heaters. Avoid placing air intake vents near exhaust vents from adjacent buildings or sources of automobile exhaust. Never place an air intake in a garage, for instance.
3. Make sure that the joints between the termination vents and the walls are weather sealed.

Wiring and Controls

CAUTION

Before performing any service to your RecoupAerator, switch off the unit and disconnect power from the unit. You must disconnect power by either unplugging the unit or by switching the applicable breaker in your breaker box to off. Otherwise, the main power to the unit will remain hot and could cause serious bodily injury.

Basic Electrical Wiring

The RecoupAerator Model 200DX is supplied with a wall mountable controller which may be mounted near the unit or in a remote location. Follow all applicable electrical codes.

The RecoupAerator can be wired to run in a number of different ways. This section of the manual describes each benefit option and shows the wiring procedure to accomplish them.

Factory Default Settings

Airflow. This unit contains two blower motors, each independently controlling the airflow coming into the building (Blower 1, supply), and leaving the building (Blower 2, exhaust). The unit has the capability of lowering the airflow from the building going to the outside by a selectable set of offset jumpers on the three-motor control board. Factory settings provide for “balanced” airflow, that is, equal airflow both coming into the building and exiting the building.

Input. The RecoupAerator comes equipped to handle several different types of control input. From the factory, The RecoupAerator is wired with the Wall Dial Control, unless otherwise specified at the time of order.

EconoCool. This unit comes with an economic ‘night’ flush feature. There is a small silver toggle switch mounted next to the Main Power switch to turn EconoCool ON and OFF. Please see the ‘econocool’ section in this manual for further detail.

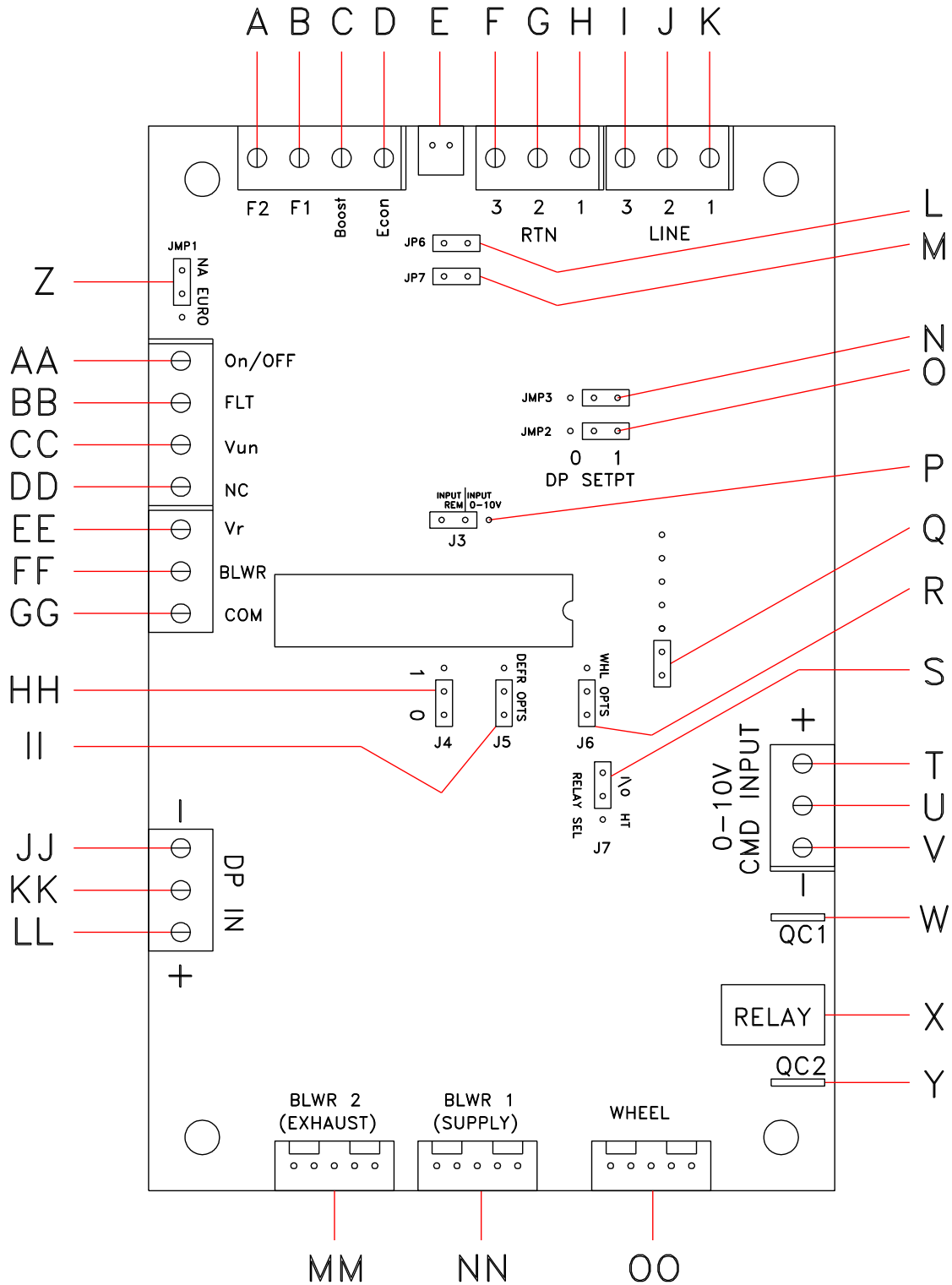

Three-Motor Main Control Board

Three-Motor Main Control Board Description

- A. **F2:** Wiring input from furnace. 24 VAC common. In some cases “C” post from thermostat wiring on the furnace. If wiring to furnace, REMOVE Jumpers at L and M (JP6 & JP7).
- B. **F1:** Wiring input from furnace. 24 VAC line. In some cases “G” post from thermostat wiring on the furnace. If wiring to furnace, REMOVE jumpers at L and M.
- C. **Boost input:** When this post receives a 24 VAC from I, J, or K, the unit will be turned on to high speed (max air flow).
- D. **EconoCool input:** When this post receives a 24 VAC signal from I, J, or K, the EconoCool function will be enabled.
- E. **Temperature input:** Temperature thermistor located at the incoming air stream (duct 1) connects through this input.
- F. RET 1: 24 VAC return post. Common from the internal transformer.
- G. RET 2: 24 VAC return post. Common from the internal transformer.
- H. RET 1: 24 VAC return post. Common from the internal transformer.
- I. LINE 3: 24 VAC line post. Line voltage from the internal transformer.
- J. LINE 2: 24 VAC line post. Line voltage from the internal transformer.
- K. LINE 1: 24 VAC line post. Line voltage from the internal transformer.
- L. **JP6:** Jumper connects 24 VAC Line from internal transformer to F1.
- M. **JP7:** Jumper connects 24 VAC return from internal transformer to F2.
- N. **JMP3:** Offset / DP Set point jumper. See Air Flow Offsets
- O. **JMP2:** Offset / DP Set point jumper. See Air Flow Offsets
- P. J3: When J3 is in the 0-10V position, JMP1 MUST be in the EU position. J3 Selects control input from either the Wall Dial Control, or a 0-10V DC input voltage (at T and V).
- Q. **Programming jumper.** Must be in place for to run RecoupAerator.
- R. **J6:** w/ furnace tie to set minimum airflow to 70CFM in 1 position
- S. **J7:** Relay selection. Jumper selects whether the normally open relay (X) closes when the unit turns on (position I/O), or when the temperature thermistor reads below 10°F (position HT). Default is position I/O.
- T. **0-10V DC input:** When J3(P) is in the 0-10V position, a positive line voltage 0-10V DC may be used to control the RecoupAerator operation. When J3 is in 0-10V position, JMP1 MUST be in EU position for the 0-10V input to work.
- U. Not connected. Empty socket.
- V. **0-10V DC input:** When J3 is in the 0-10V position, this post connects to the negative side of the 0-10V DC control.
- W. **QC1:** Quick Connect 1. Used as an auxiliary output control option. QC1 will be electrically connected to QC2 when the relay (X) is closed. Max rating: 1A@24VAC.

- X. **Low voltage pilot duty relay.** Normally open. Closes according to selection made at J7 (S). Default: closes when the ERV is turned on.
 - Y. **QC2:** Quick Connect 2. Used as an auxiliary output control option. QC2 will be electrically connected to QC1 when the relay (X) is closed. Max rating: 1A@24VAC.
 - Z. **JMP1:** Remote control input selection. Default wall controller in the North American remote wall control (NA position). J3 (P) must be in REM INPUT position. When J3 is in 0-10V position JMP1 MUST be in EU position for the 0-10V input to work.
 - AA. **On/Off** terminal. Wiring to mating terminal on NA wall controller.
 - BB. **FLT** terminal. Wiring to mating terminal on NA wall controller.
 - CC. **Vun** terminal. For wiring to mating terminal on NA wall controller.
 - DD. **NC** terminal. *Do not wire to this Empty terminal.*
 - EE. **Vr** terminal. For wiring to mating terminal on NA wall controller.
 - FF. **BLWR** terminal. For wiring to mating terminal on NA wall controller.
 - GG. **COM** terminal. For wiring to mating terminal on NA wall controller.
 - HH. **J4:** Blower control jumper. Default is '0' position for CFM control.
 - II. **J5:** DEFROPTS: Defrost Jumper. Default position is '0' The heat wheel slows between 18°F - 8°F to prevent frost accumulation then stops when outside temperature is below 8°F. The '1' position will simply turn OFF the machine below 8°F. Position '1' is intended for use with a fresh air pre-heater.
 - JJ. **DP IN:** Delta Pressure Control input, negative (-). Not functional without Pressure Control Transmitter option. Recoupaerator has air flow offset capabilities, see airflow Offsets in this manual
 - KK. Not connected. Empty socket.
- DP IN:** Delta Pressure Control input, positive(+0) side. Not functional without Pressure Control Transmitter option. Recoupaerator has airflow offset capabilities.

Low Voltage Accessories:

Your RecoupAerator is designed with the latest low voltage control technology. Equipped with a 20 volt-ampere (VA), 120 to 24 VAC transformer, this auxiliary low voltage power can be accessed at the three-motor Main Control board inside the power switch cover. Use the screw terminals labeled 24 Vac LINE (1, 2, or 3) and 24 Vac RETURN (1, 2, or 3) to power low voltage accessories.

Limitations: *Note that your RecoupAerator uses 4 VA under normal operating conditions, thus leaving 16 VA for optional accessories. When designing your control strategy, keep in mind that you can over draw the 20 VA.*

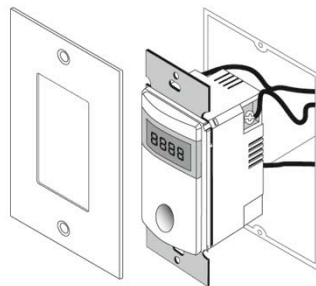
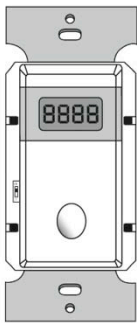

Bath Boost Timer 1.4 VA

CO2 Sensing Switch 3 VA



Pressure Transmitter 3 VA

Wall Dial Flow Control – Included



The 200DX comes equipped with this Wall Dial Flow Control pre-wired. Follow these steps to re-wire the dial control to a more convenient location.

1. Run the unit before un-wiring, to be sure that everything is working.
2. Following all applicable electrical codes, Determine the location where the Wall Dial will be mounted and the length of 6-conductor wire (20/22 gauge) necessary to run from the RecoupAerator to the Wall Dial

3. Be sure the RecoupAerator is switched OFF and unplugged. Using a flat screw driver or a 5/16 nut driver, remove the exterior electrical cover.
4. Un-wire the Wall Controller from the RecoupAerator, note the terminal labels.
5. After stripping 1/4" of insulation from each of the wire ends, complete the wiring by matching each labeled between the 3-Motor Main Control and the Wall Dial. Be sure all connections are secure by lightly pulling each wire.
6. If wiring to a furnace, you MUST REMOVE jumpers JP6 and JP7. If NOT wiring to a furnace, jumpers JP6 and JP7 MUST be in place. See furnace wiring for more detail in this manual.

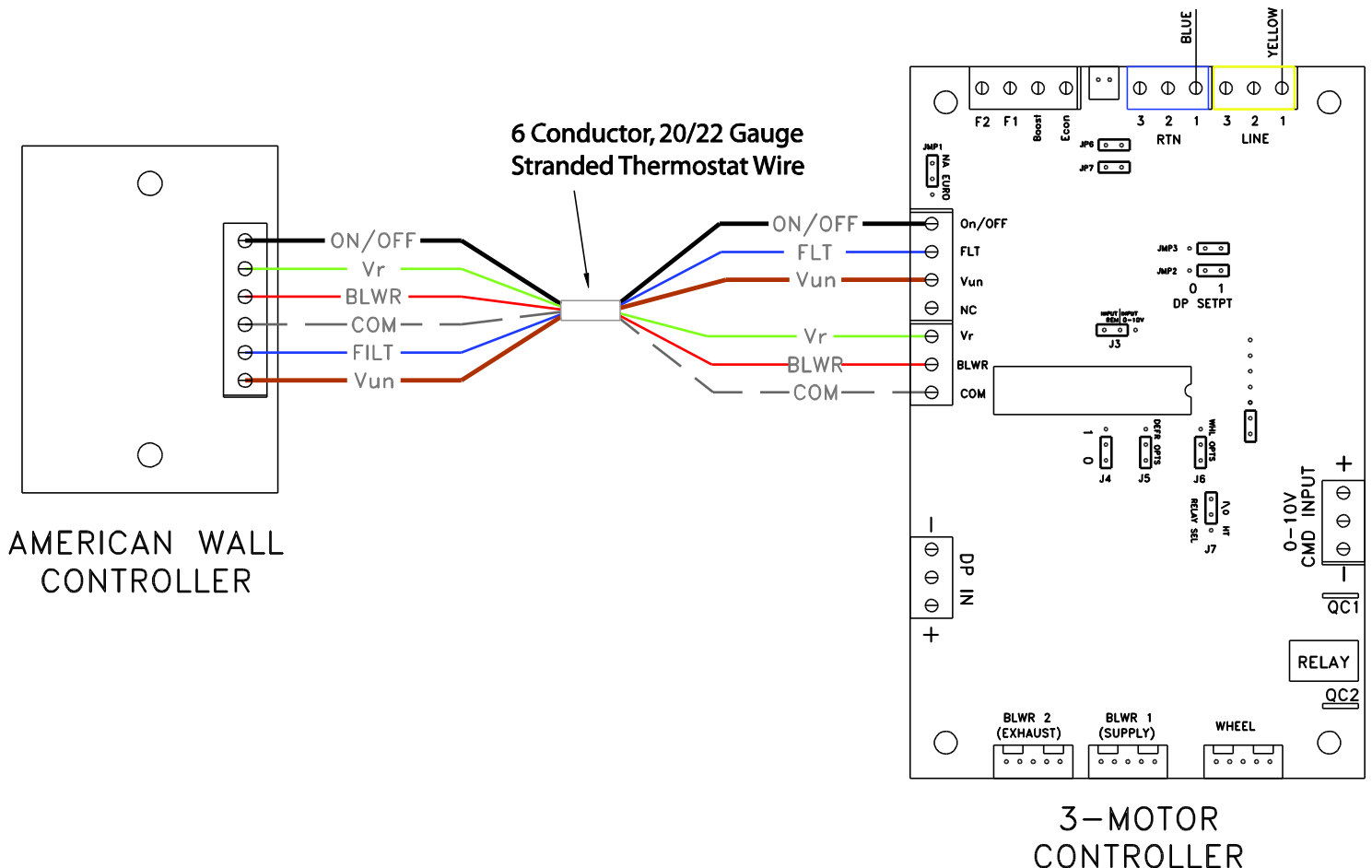

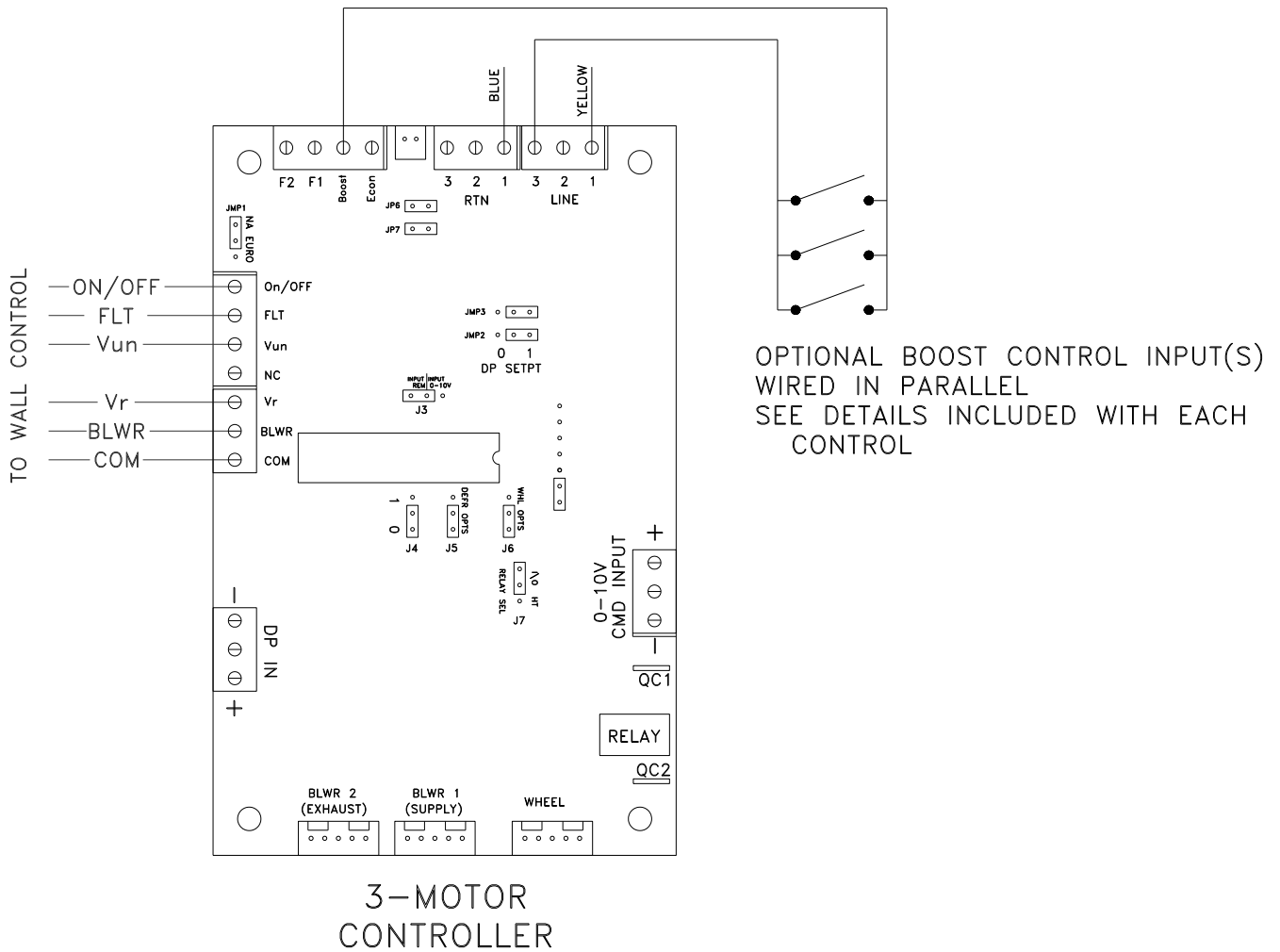

On the three-motor controller, there is one screw terminal specifically for **Boost** input. This feature allows for an override of the RecoupAerator's variable speed ability. Boost is useful for running at maximum airflow (200CFM) using a low-voltage signal input such as the optional Boost Timer. Typically, Boost inputs include bathroom timers, CO₂ monitors, and humidity monitors. Note that all Switch relays must be capable of switching LOW VOLTAGE (24vac). *High Voltage Contacts (110VAC) will often fail used with 24VAC because of the lack of required high voltage arcing to keep them clean and functional.*

EconoCool™

Each RecoupAerator is EconoCool™ equipped, so the outside air during summer months may be utilized to cool your home or business (e.g., during the night), thereby providing Energy Savings and Comfort. The built-in temperature sensor on the incoming air stream automatically stops energy recovery between 55° and 70° Fahrenheit. This feature would typically be turned ON when entering the cooling season (summer), and OFF when leaving the cooling season (winter).

The EconoCool™ toggle switch must be ON for this function to work.

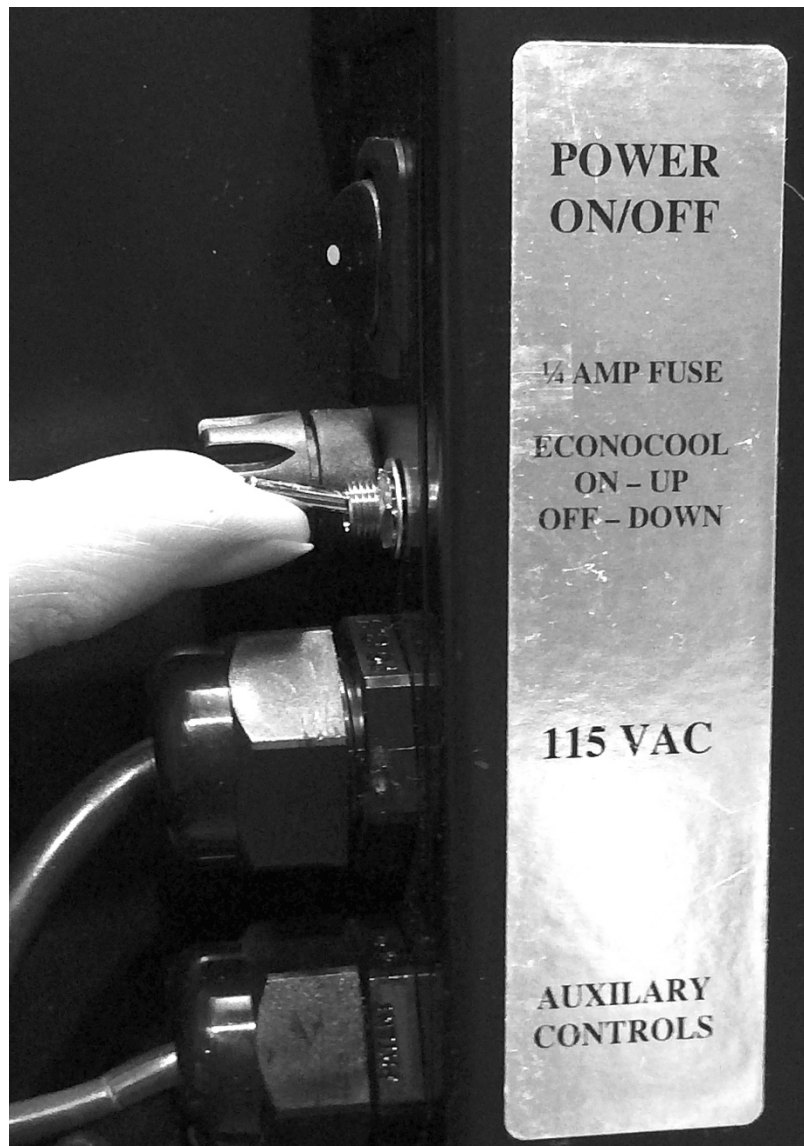

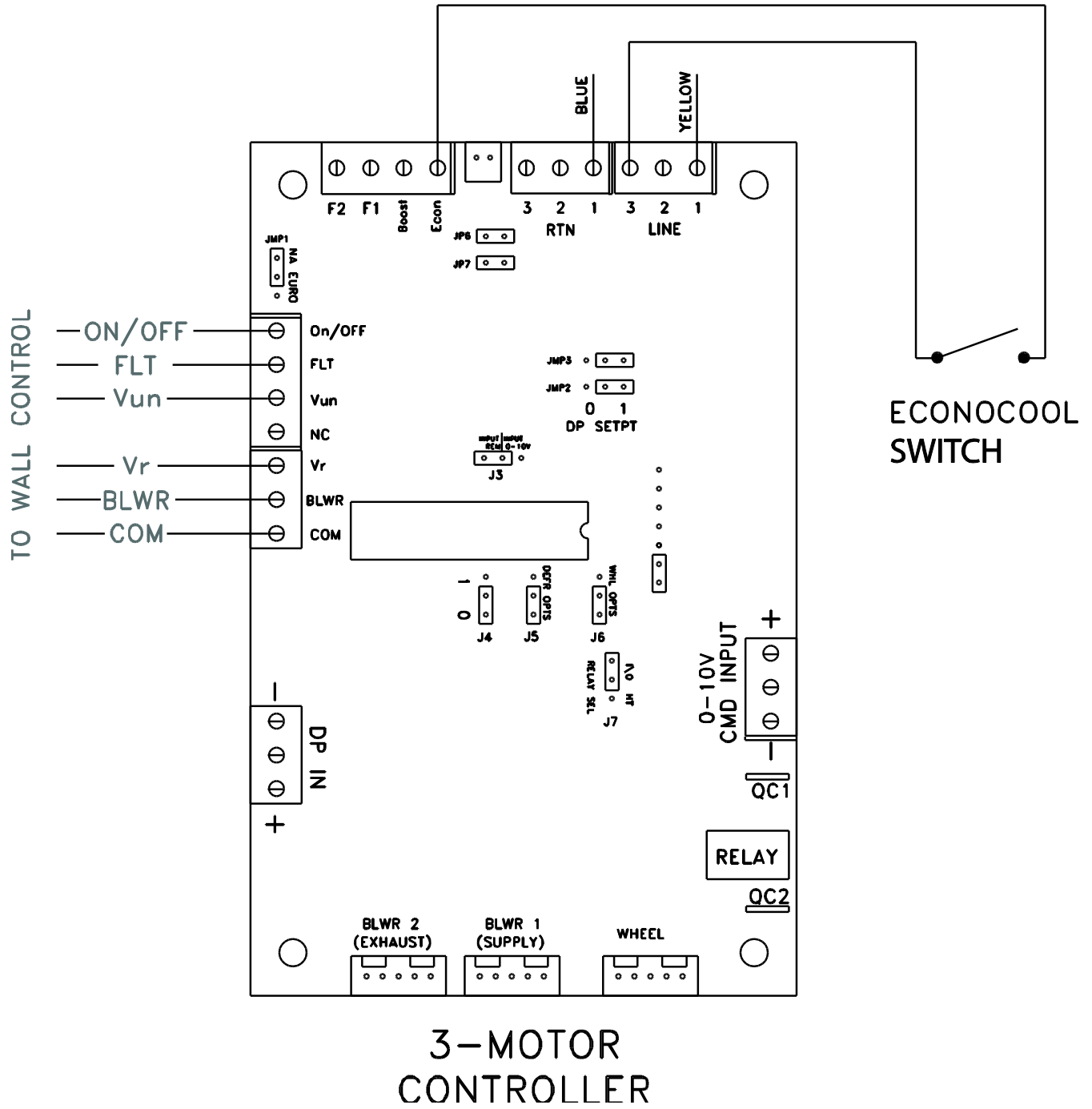

Wiring to a Furnace/ AC Air Handler

For this purpose, never use a device that cycles the main power to the UltimateAir 200DX. Cycling main power ON/OFF is detrimental to the system electronics and will void the warranty.

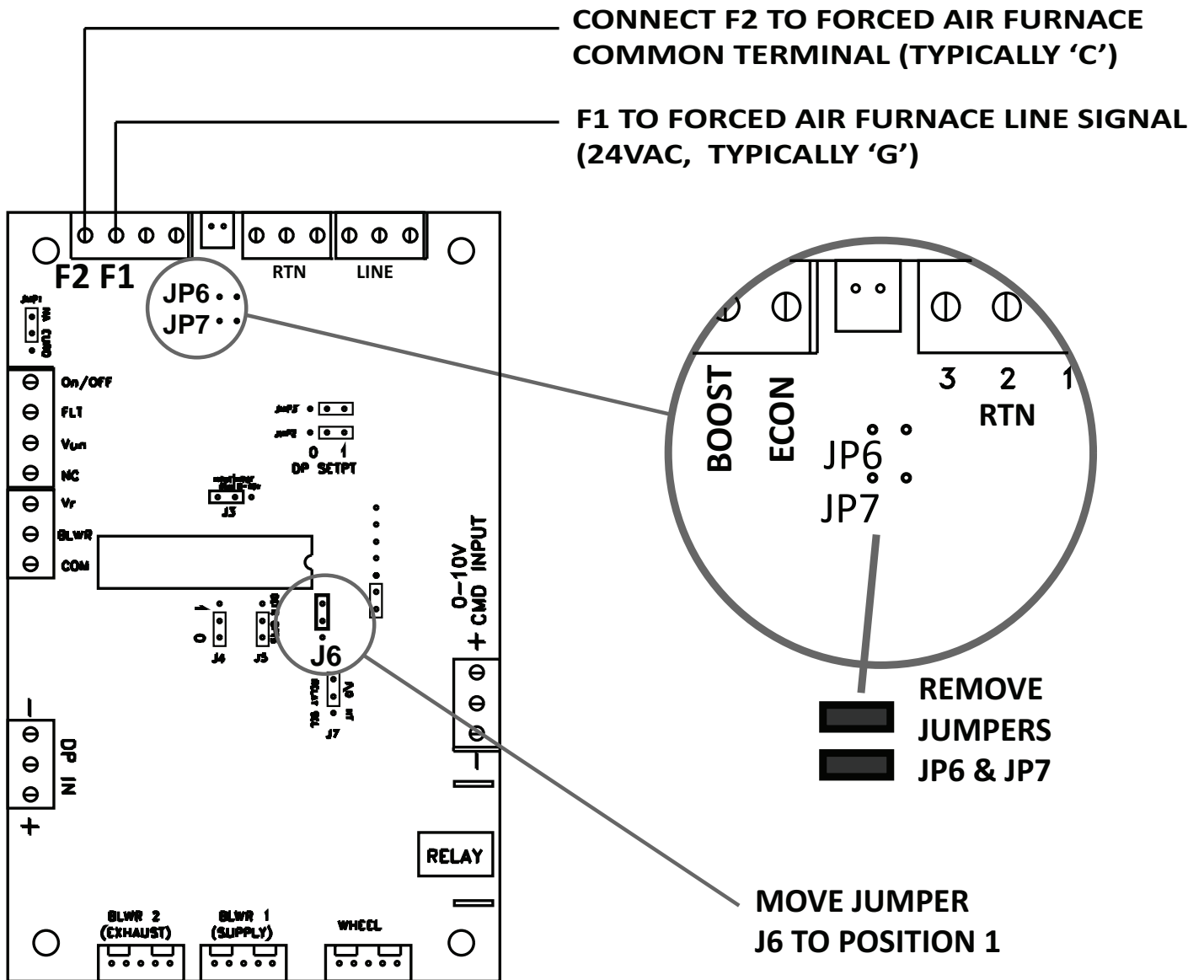

**THREE MOTOR CONTROL
ULTIMATEAIR 200DX**

Wiring to a Furnace/ AC Air Handler Continued...

When integrating the UltimateAir ERV with existing forced air systems, it may need to operate in conjunction with the furnace/AC air handler.

1. On the Furnace, locate the 24 VAC (low voltage) which activates when the Furnace blower is ON. Furnace outputs are generally marked G for “Go/Run” and C for Common; refer to the particular furnace manual for details.
2. **REMOVE jumpers JP6 and JP7**, located just under the furnace F1 & F2 input terminals on the UltimateAir main board.
3. **Run two wires** (20/22GA) from the furnace to the input terminals on the UltimateAir 200DX main control marked **F1** (24 VAC Line) and **F2** (24 VAC common). The UltimateAir 200DX will now run only when the furnace air handler is ON.
4. **Move Jumper J6** from its default position (‘0’) to position ‘1’. This sets the minimum airflow to 70 CFM. If the airflow range is left at the default settings, the 200DX may not be able to overcome the static pressure of the furnace or AC air handler.

Note- When wired to run with the furnace blower, the 200DX will run at the Flow Speed Set on the 200DX Wall Dial. The green light on the Wall Dial will flash when the furnace blower is not running.

Wiring to Thermostat or Dry Contact Switches

This control scenario will utilize the UltimateAir 200DX internal 24Vac transformer power for ON/OFF function via any external contact switch.

On the UltimateAir 200DX 3Motor Main Board, **REMOVE jumper JP6**, located just under the Furnace connections F1 &F2. Run one Wire from the LINE Terminal to the Dry Contact Device you want to use. Run a second wire back from the Dry Contact Device to the UltimateAir 200DX **F1** Terminal.

Flow Offset Pressurization

Implement the optional airflow offset only if you're a qualified specialist familiar with indoor pressure-related issues.

The RecoupAerator can affect your building indoor air pressure by allowing for an airflow offset between the incoming and outgoing air streams.

Offsetting Flow rates can discourage moisture and gases from entering the wall cavities.

The factory default setting is balanced airflow into and out of the space.

(Boost mode will over-ride offset pressurization)

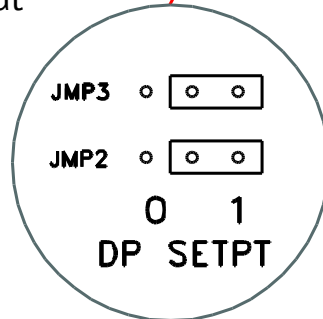
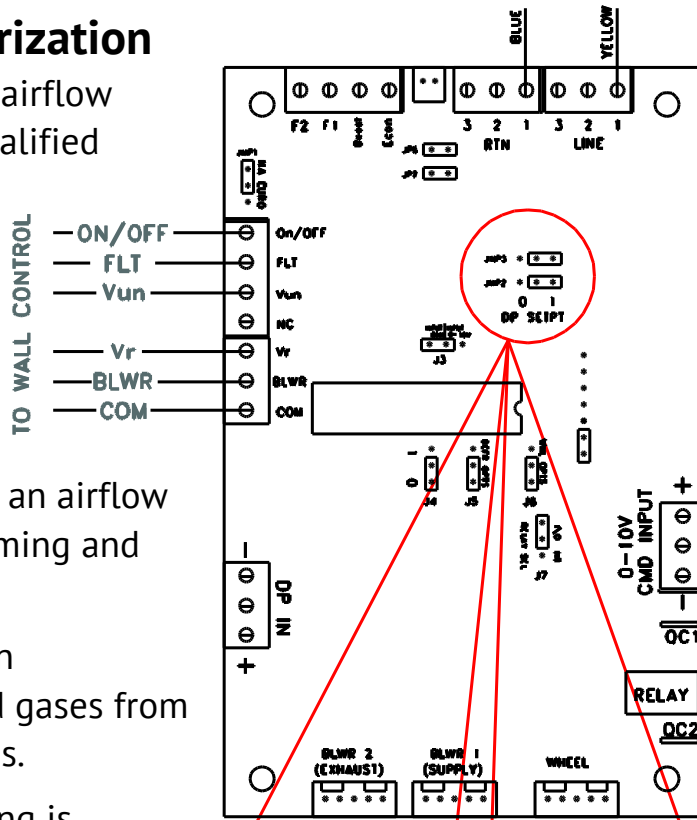

FLOW OFFSET = 0CFM

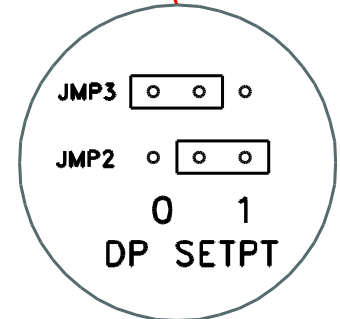

FLOW OFFSET = 20CFM

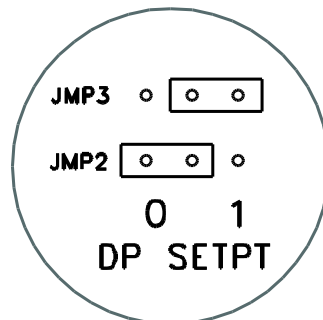

FLOW OFFSET = 40CFM

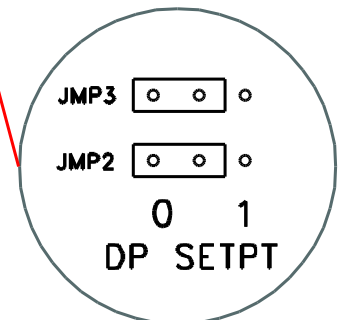

FLOW OFFSET = 60CFM

Flow Offset Pressurization ...

1. **Shut OFF the main power** switch and disconnect the 110vAC power source.
2. **Locate the Three-Motor Main Control Board** mounted under the power switch cover.
3. **Locate the jumpers labeled JMP2 and JMP3** which determine the offset between the two air streams at the highest air flow. Notice on the board directly beside these jumpers are the numbers “0” and “1”. These numbers refer to the position of the jumpers. The factory setting is: JMP2 & JMP3 = 1, which means no offset is in effect and the unit will provide a balanced & equal supply and exhaust flow.
4. **Move the jumpers** to their corresponding air flow offset as follows:

JMP2 & JMP3 = 1 No offset/ balanced flow default setting

JMP2= 1, JMP3 = 0 ~ 20 CFM Offset at HIGH flow

JMP2= 0, JMP3 = 1 ~ 40 CFM Offset at HIGH flow

JMP2= 0, JMP3 = 0 ~ 60 CFM Offset at HIGH flow

*Note: airflow is approximate

When dial is set at maximum high airflow, the unit will drop the exhaust airflow by the specified amount. At lower airflow settings the air streams will become proportionally closer together until they are equal at the minimum low airflow.

0-10 VDC Input Signal Control System

Your RecoupAerator can be programmed into a “smart house” control, so it may be controlled remotely or using any 0-10 VDC control signal.

To set up a 0-10 VDC input signal control system, **disconnect all power to the unit.**

1. Set jumpers JMP1 to the EU position, and J3 to the 0-10V INPUT position on the three-motor controller as shown in the drawing below to enable the 0-10 VDC control input.
2. If a Wall Dial Control is attached to the unit, remove it. You do not need a Wall Controller when operating the unit with a 0-10VDC input control signal.
3. Locate the two screw terminals labeled “0-10V CMD INPUT”, as shown above, and connect the signal control wires to these posts as indicated.

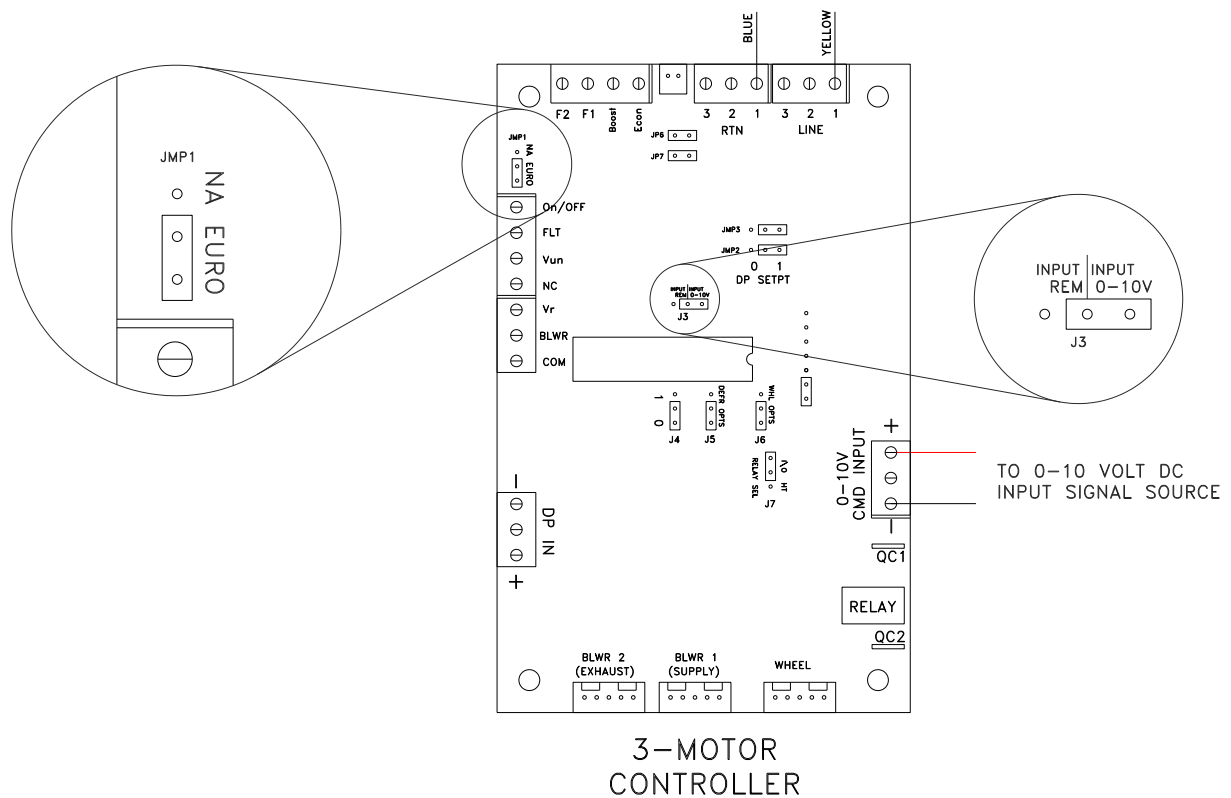

Using a 0-10 VDC Input Signal Control System...

Boost, EconoCool™, air flow offsets, and furnace input functions are still operational when using the 0-10vDC input signal to control blower speed. Review following table for the vDC input versus airflow relationship to help program your control.

Vin (0-10V)	CFM	POWER (watt)	Watt/CFM	
0.9	36	24	0.67	LOW
1.6	48	29	0.61	
2.2	59	36	0.61	
2.8	73	44	0.61	
3.4	84	55	0.65	
4.1	97	69	0.71	
4.7	111	87	0.78	MED
5.3	122	105	0.86	
5.9	135	125	0.93	
6.6	150	148	0.99	
7.2	161	174	1.08	
7.8	173	201	1.16	
8.4	184	230	1.25	HIGH
9.0	192	258	1.34	
9.7	195	267	1.37	

Note *0 – 0.5 vDC = OFF*
0.9 vDC = ON and lowest flow setting

Auxiliary Output (Optional)

Your RecoupAerator allows you to run auxiliary options, such as duct power dampers, fans, humidifiers, and dehumidifiers. For instance, you can use the auxiliary output to turn on a furnace fan. Your RecoupAerator is equipped with a low-voltage pilot-duty relay (normally open) on the three-motor controller. The relay controls any auxiliary options you may want to operate in conjunction with your ventilation unit. When the RecoupAerator is turned on by the Wall Dial Control or by other means (e.g., fan, furnace, boost, and building input), the relay switches from normally open to closed, completing the circuit between QC1 (1/4" quick-disconnect tab) and QC2 (1/4" quick-disconnect tab), denoted as “W” and “Y” on the 3 Motor Main Control description. Jumper J7 must be in the I/O position for this relay to activate on unit start.

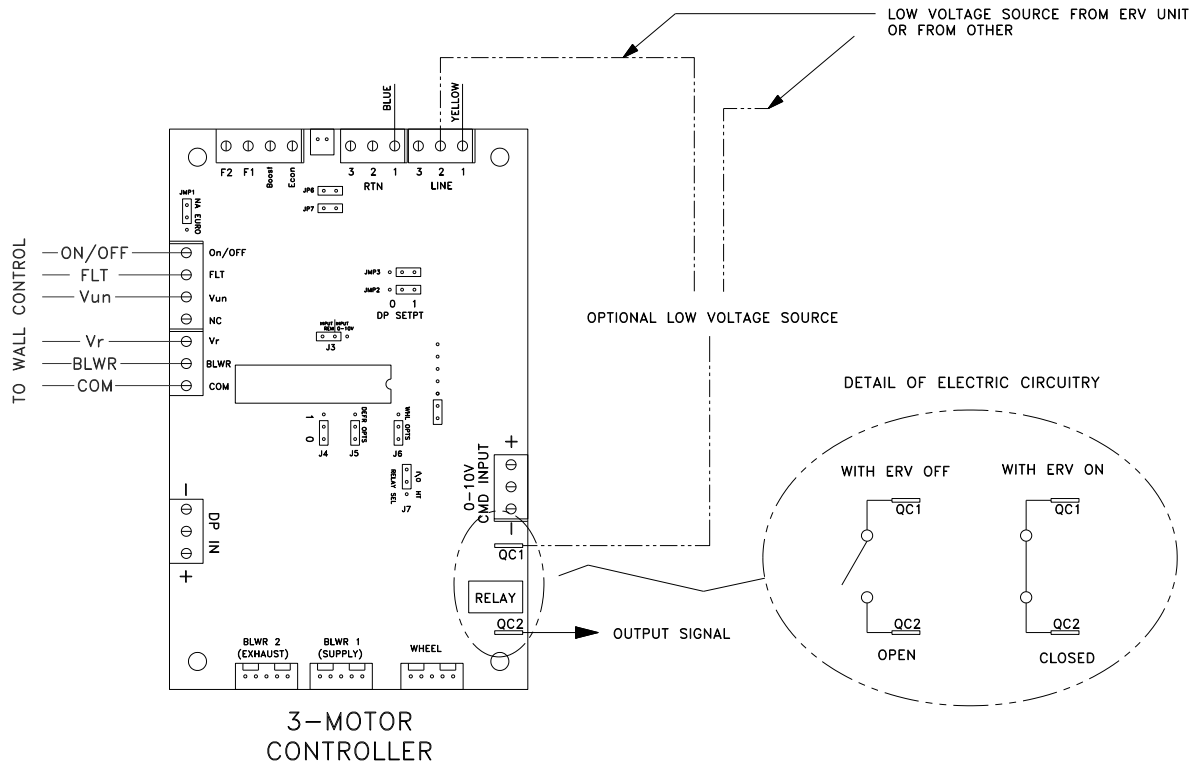

Max contact rating: 1A@24VAC
 Minimum permissible load: 1mA@5VDC

Service & Maintenance

Tech Videos @ <https://www.youtube.com/user/RecoupAerator/videos>

CAUTION

Before performing any service to RecoupAerator, disconnect power to the unit. You must disconnect power by either unplugging the unit or by switching the applicable breaker in your breaker box to OFF. Otherwise, the main power to the unit will remain hot and could cause serious bodily injury.

Maintenance Check List

- ✓ Check pre-filters and energy transfer/filtration material every six months or when the *Check Filter* light comes on. Which ever comes first.
- ✓ Clean or replace the filtration material at least once per year.
- ✓ Clean pre-filters every 3 to 4 months if continuously operated.
- ✓ Check exterior weather caps regularly.
- ✓ Lightly vacuum or dust the cabinet interior annually.



Reset the light thru the small hole in the faceplate just below the light. A small object such as a paper clip or the included Allen Wrench inserted in the hole of the faceplate and held for 2 seconds will turn the light OFF.

The Check Filter light comes on every 90 days of continuous operation. Because of differences in indoor and outdoor environments, the filters may or may not need cleaning every 90 days. The light is only a reminder to check the filtration material.

Exterior Weather Hoods

Check your exterior weather hoods periodically throughout the year to ensure that the fresh air inlet and stale air exhaust hoods mounted on the outside of the building do not become clogged with debris such as leaves, grass, snow, or nests. Remove any debris by hand or wipe out the caps with a dry cloth.



Aluminum Pre-filters

Clean the aluminum pre-filter at least once every six months. Clean more frequently if necessary.

1. Disconnect power to the RecoupAerator
2. Open the filter access cover and foam insert blocks
3. Pull pre-filters from slots.
4. Check the pre-filter for build-up which may be cleaned by soaking in warm water. If the filter is clogged, a new set can be purchase from UltimateAir. The pre-filter should be mostly dry before reinstalling.
5. Replace the filter cover foam insert blocks and access cover
6. Restore power to the unit.

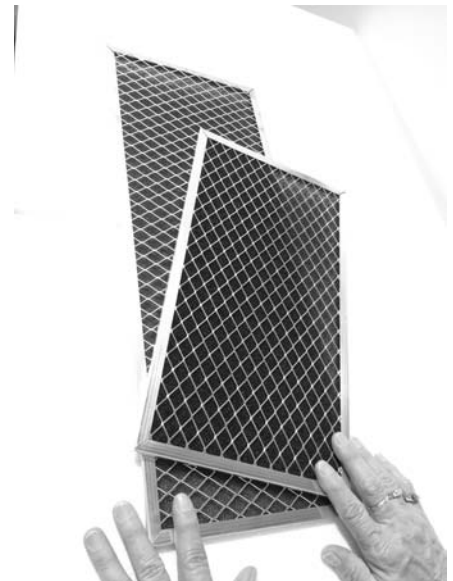

Energy Transfer/Filtration Material (Filter Pies)

To order replacement filtration materials, visit us online at:

www.ultimateair.com or call 800.535.3448

UltimateAir's patented energy transfer wheel contains six removable filter pie wedges, which require replacement after three to four cleanings. These pies are the 'energy transfer/filtration material'. They not only filter incoming air, they also transfer heat and moisture from one air stream to the other giving the machine the 98% Heat/Energy recovery rating.



1. **Disconnect Power**
2. **Open Latches to remove the Filter Access cover**
3. **Remove the aluminum pre-filter** as explained in the Aluminum Pre-Filter section on the previous page
4. **Inspect Filters** If the energy transfer/filtration material is dark gray or darker, it should be hand washed or replaced. Pull out the exposed filter material "pie wedges", manually rotating the wheel to access the remaining wedges
5. **Rotate the wheel by hand**, making sure the pieces are completely and evenly replaced below the level of the spokes so the filter wedges do not drag when the wheel rotates. Access both sides of the wheel to adjust the wedges to center of the wheel.
6. **Replace the aluminum pre-filter** and the filter access cover

Changing the Belt

1. **Disconnect Power**
2. **Open Latches to remove the filter access cover** then the Front Panel *See Illustration*
3. **Remove the two screws** mounting the motor/drive roller assembly in place. The 7mm Hex Head screws are visible and closest to you. The motor wiring may remain connected. The rear of the motor mount sits on two snap top posts.
4. **Carefully rock the motor/drive roller assembly** loose to remove.
5. **Replace Drive Roller Belt** by stretching the new belt onto the pulleys.
6. **Re-Install motor / drive roller assembly** into the unit by first aligning the rear posts, then replacing the two screws.
7. **Re-Install white foam board** with the metal front cover.
8. **Operate unit** with wheel visible through top door to verify rotation.
9. **Replace top Filter Access**

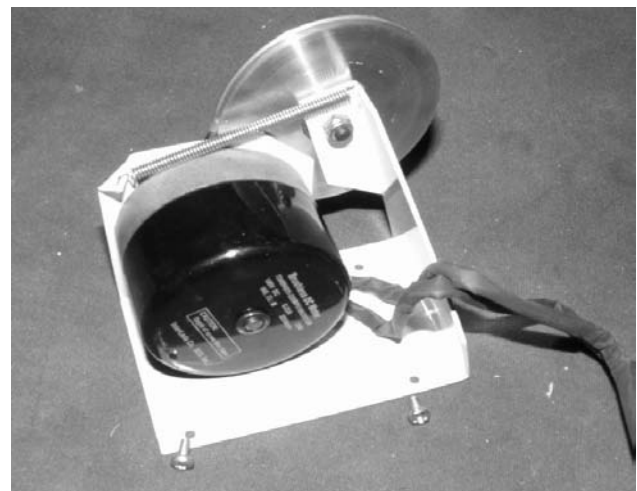
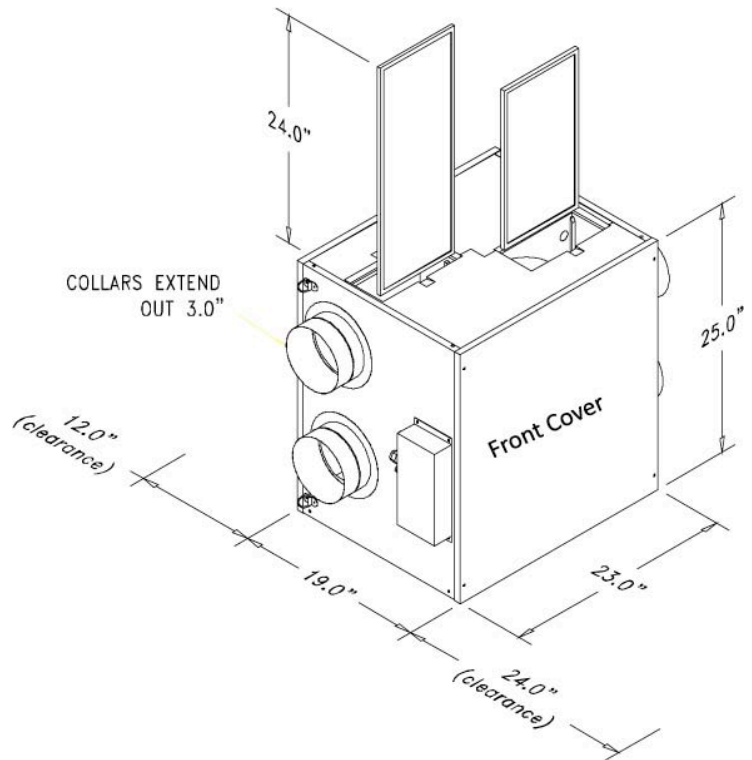

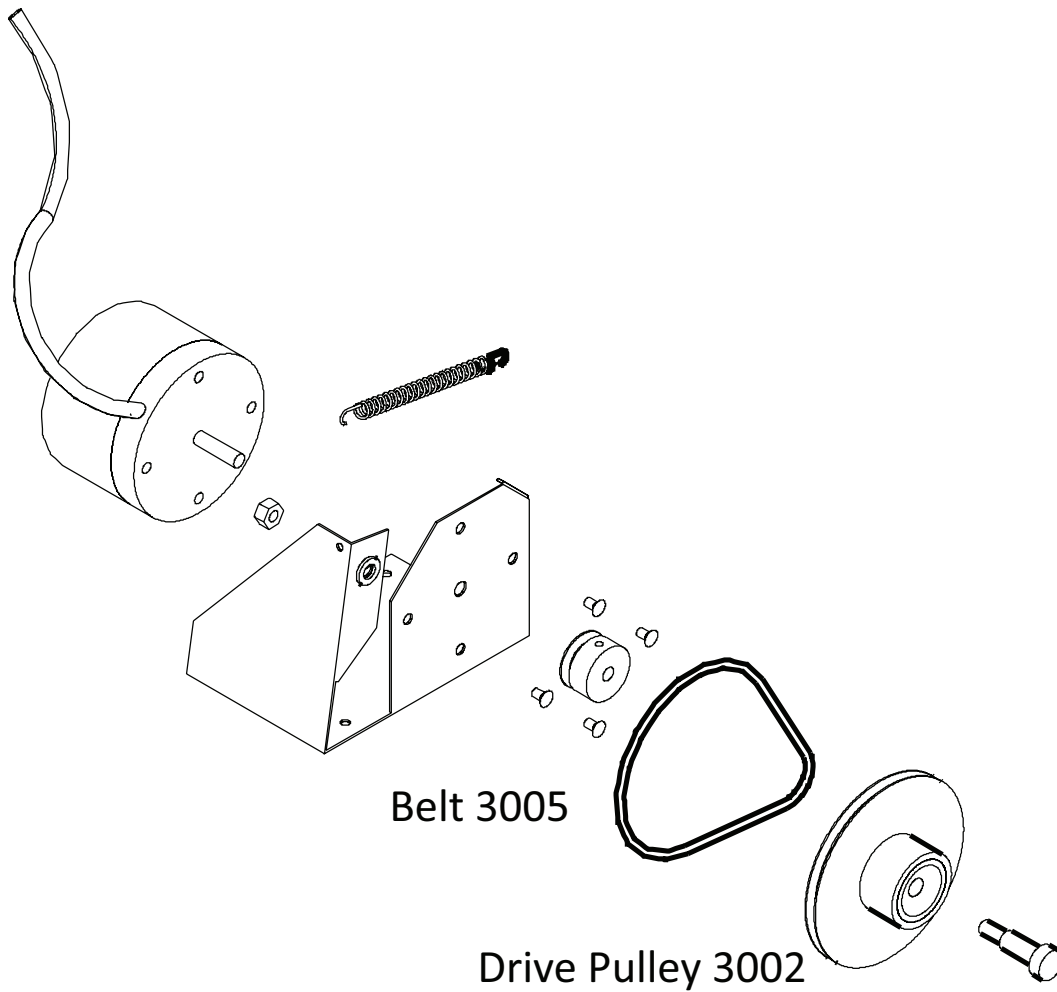

Filter Wheel Drive Motor Assembly 7000

Part No.	Part Description	Qty
2009	Drive Roller / Motor Mount	1
3001	Small Motor Pulley	1
5001	M6 Metric Washer	1
5002	Metric Shoulder Screw	1
5003	Metric Locknut	1
5009	Flat Head Machine Screw	4

Troubleshooting

(Tech Support 800.535.3448)

Problem	Possible Cause	Recommended Solution
Green Light on Wall Dial Control does not come on	Power switch mounted on machine is Off.....	Check that Main 110VAC switch
	Accessories connected to the unit are not powered or wired correctly	Use a jump wire from LINE 24V on the Main Board mounted inside the power switch cover to the boost BST terminal on the same board to see if machine responds by running at full flow. The problem may be in the Wall Dial if Boost works correctly.
	Blown fuse.....	Check and replace the main fuse. ¼ amp Verify all connections and replace any loose wiring
	At least 100 VAC may not be reaching the machine	Make sure that NA/EURO jumper is in the correct position on main board
	Wires from the Main Control Board to the wall Dial may be crossed, Notice order of wire labels	
Green Light on Wall Dial Flashing	Auto Frost Protection shuts Off Machine below 10° F (-12C) -Temperature Probe Problem. Machine electrically Tied To Furnace and is currently not Running	Wait for outside temperatures to rise above 10° F or Purchase an efficient UltimateAir pre-heater for operation below 10° F (-12C)

Excess humidity	<p>Flow speed set too low (during heating season)</p> <p>RecoupAerator not operating continuously (during heating season)</p> <p>Moisture-producing source (e.g., indoor pool, hot tub, or unvented crawl space)</p>	<p>Set speed higher at wall controller</p> <p>Operate RecoupAerator continuously</p> <p>Consider additional exhaust fans in moisture-producing areas (e.g., bathrooms and kitchens)</p>
What's that sound?	<p>Small noises in the system</p> <p>Obstructions in pre-filters and ducts</p> <p>Heat recovery wheel rubbing on insulation</p>	<p>Insulated Flexible duct connected to the machine for 3 feet will minimize noise transmission through hard duct</p> <p>Clear airways of any and all obstructions, including termination vents and pre-filters</p> <p>Make sure pies are flush with heat recovery wheel edge and not rubbing</p>
Poor air flow	<p>Leaves or similar may be obstructing vents</p> <p>Restrictions in ductwork</p> <p>Dirty energy filtration material</p> <p>Ductwork too long, too many bends/elbows</p> <p>Wall controller is not at the right setting</p>	<p>Remove obstructions from any and all airways</p> <p>Remove any duct obstructions, excessive bends, and improperly</p> <p>Contact your HVAC service professional to fix ducting</p> <p>Adjust wall controller setting</p>
Cold air	<p>Un-insulated duct in unconditioned air space</p> <p>Heat recovery wheel not rotating or one of the two blowers are not running</p>	<p>Insulate all duct work in unconditioned air spaces</p> <p>Check for broken or slipping wheel belt</p>

Warranty & Installation Record

Date of Purchase:		Model #:	200DX
Date of Install:		Serial #:	
Contractor Info			
Company		Contact Person	
Address			
City, State Zip		Phone	
Notes			

Warranty Information

Be sure to promptly return your warranty registration or online @ <http://www.ultimateair.com/warranty-reg>

The UltiamteAir 200DX RecoupAerator is guaranteed to be free from defects in materials or workmanship for Two (2) years from the date of purchase. See Warranty card included in original packaging for complete warranty information. If you have questions concerning your warranty email us: info@ultimateair.com