

## UltimateAir® ER80M

### 20-80 CFM



UltimateAir® RecoupAerator® ER80M

UltimateAir has created the Ideal solution to limited space ventilation. Engineered to be versatile, the duct port layouts allow this ERV to fit into any home, multi-unit, condo, hotel or space limited project in any orientation.

Controls and EC motors allow complete variable fresh air flow 20 - 80 CFM.

Independent Blowers

96% Energy Recovery ASE

Engineered and Made In the United States

Tested CAN/CSA-C439-09 - HVI Listing Equivalent

Less than 0.8 Watt/CFM

MERV 12 Filtration

UL Pending

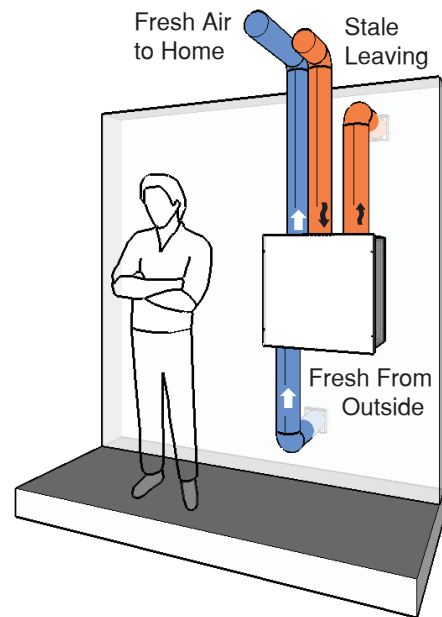
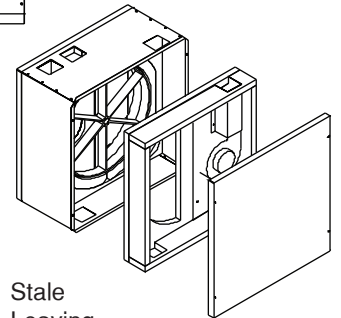
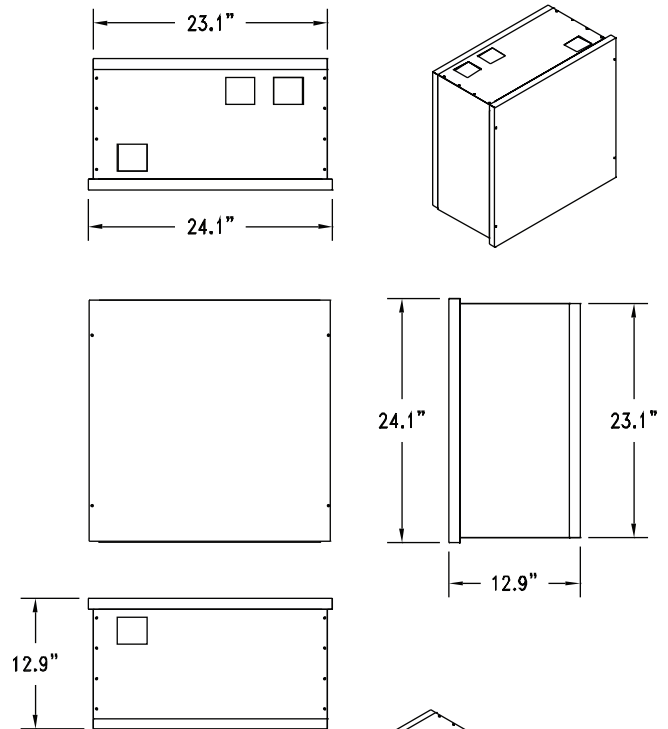

Energy Recovery PERFORMANCE					Tested CAN/CSA-C439-09		
	Supply Temperature		Net Airflow		Sensible Recovery Efficiency	Apparent Sensible Effectiveness	Net Moisture Transfer
	°C	°F	L/s	cfm			
HEATING	0	32	30	64	83	96	0.69
COOLING	35	95	30	64	53 TRE	85	0.43

