

Swagelok Coaxial Tube Fittings

Bulkhead Mounted Tees / Unions and Closure Unions Simplify the Installation of Coaxial Gas Delivery Systems

Swagelok® offers a comprehensive line of components designed for systems where coaxial assembly (tube within a tube) is required for safe gas delivery.

In addition to tube fittings a selection of weld fittings are also available. For more information on coaxial weld fittings, see Stainless Steel Tubular Fittings, MS-02-125-SCS.



SS-810-31-001

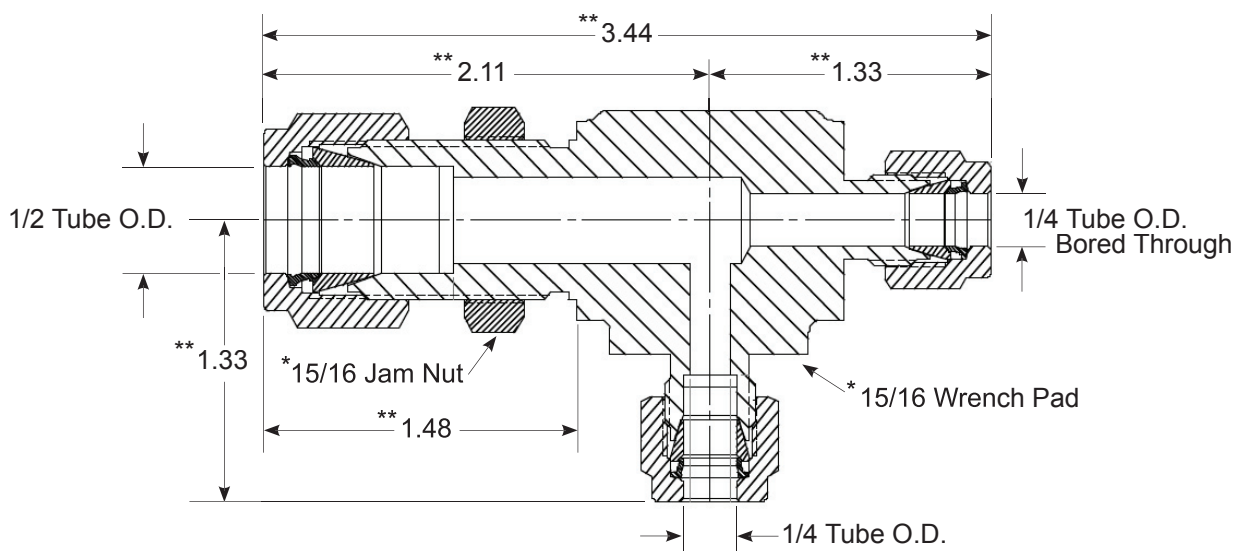

SS-810-3-0032

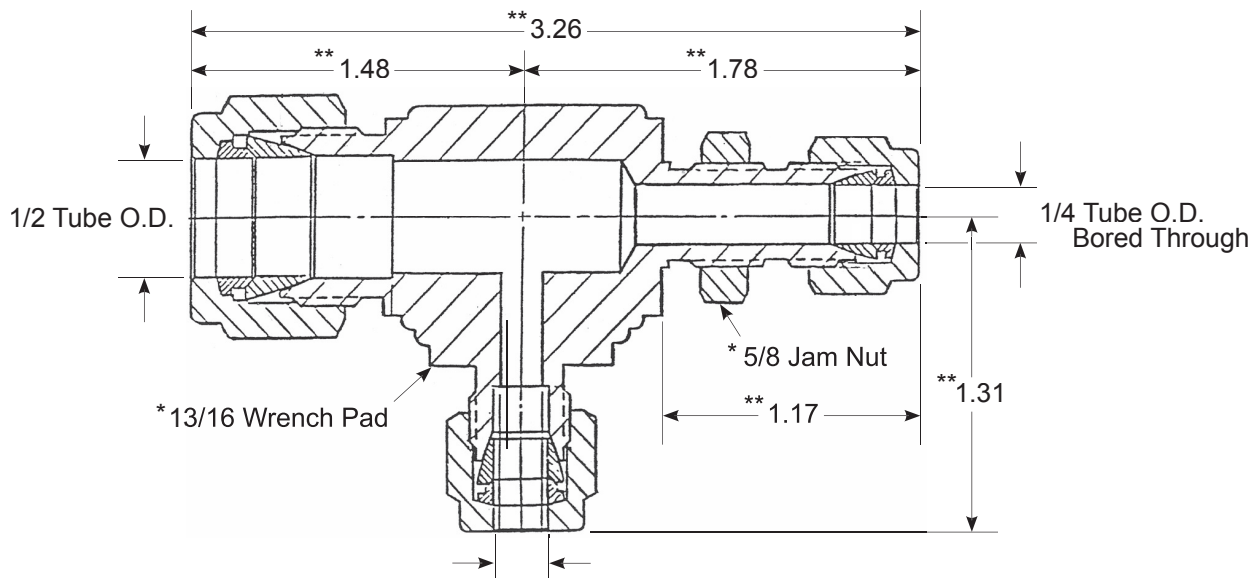

Coaxial Tee Tube Fittings

SS-810-3-0034

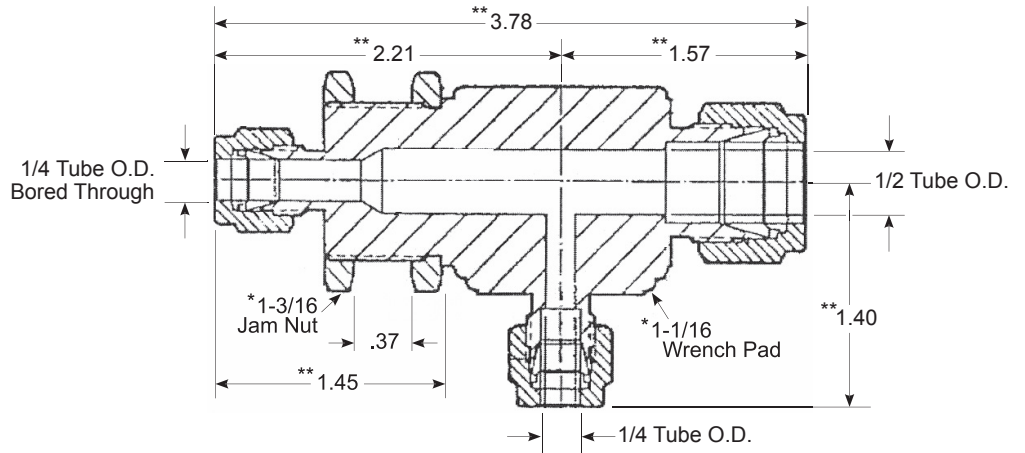

Bulkhead Reducing Union Tube Fittings

SS-810-61-4BT

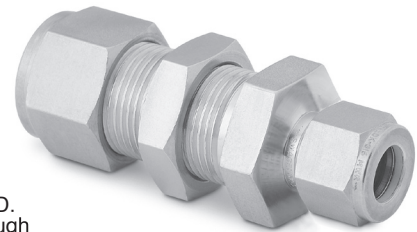
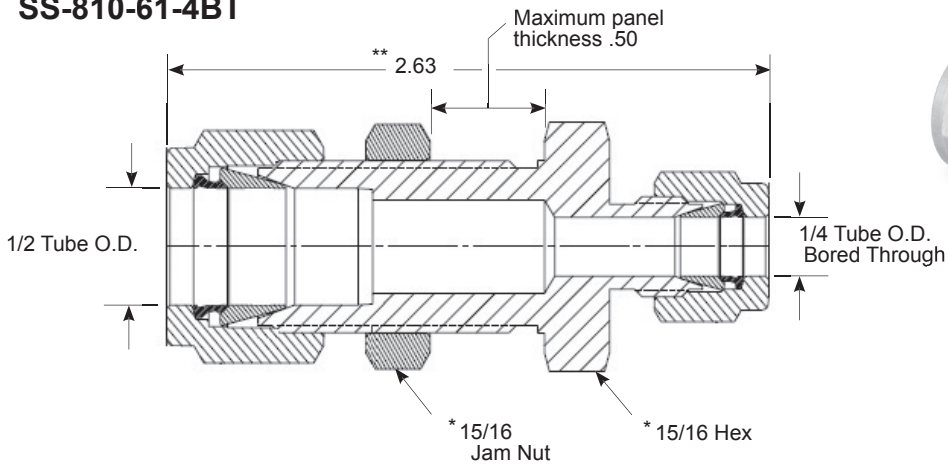

Coaxial Closure Tube Fittings

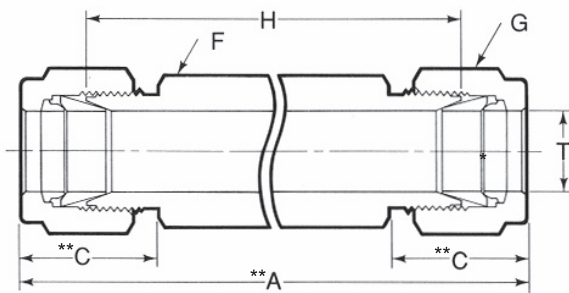

T Tube OD	Ordering Number	**A	**C	F Hex Flat	G Hex Flat	H
1/2	SS-810-6-0029	5.30	0.86	13/16	7/8	4.50
1/2	SS-810-6-0030	4.30	0.86	13/16	7/8	3.50
5/8	SS-1010-6-0016	4.42	0.86	15/16	1	3.62
3/4	SS-1210-6-0021	6.55	0.86	1 1/16	1 1/8	5.75

- NOTES:
- * Dimensions are across hex flats / wrench pad.
 - ** Are typical finger-tight dimensions.
 - All dimensions are in inches for reference only and subject to change.