

INCH-POUND

MIL-DTL-2845E(SH)

18 August 1999

SUPERSEDING

MIL-P-2845D(SH)

17 June 1991

DETAIL SPECIFICATION

PROPULSION SYSTEMS, BOAT AND SHIP; MAIN SHAFTING, PROPELLERS,
BEARINGS, GAUGES, SPECIAL TOOLS, AND ASSOCIATED REPAIR PARTS;
PRESERVATION, PACKAGING, PACKING AND STORAGE OF

This specification is approved for use by the Naval Sea Systems Command, Department of the Navy, and is available for use by all Departments and Agencies of the Department of Defense.

1. SCOPE

1.1 Scope. This specification covers the cleaning, drying, preservation, packing, marking, and storage of main propulsion shafting, line shaft bearings, stern tube and strut bearings, boat and ship propellers, propeller devices including controllable pitch propellers, shafting, and accessories thereto. It also covers repair parts, tools, and independently mounted main propulsion thrust bearings.

1.2 Levels of protection.

1.2.1 Preservation.

Level A (see 3.5.1.1 and 6.4.1.1).
Commercial (see 3.7.10 and 6.4.1.2).

1.2.2 Packing.

Level A (see 3.8.1 and 6.4.1.1).
Commercial (see 3.8.2.7 and 6.4.1.2).

2. APPLICABLE DOCUMENTS

2.1 General. The documents listed in this section are specified in sections 3 and 4 of this specification. This section does not include documents cited in other sections of this specification or recommended for additional information or as examples. While every effort has been made to ensure the completeness of this list, document users are cautioned that they must meet all specified requirements documents cited in sections 3 and 4 of this specification, whether or not they are listed.

Beneficial comments (recommendations, additions, deletions) and any pertinent data which may be of use in improving this document should be addressed to: Commander, SEA 03Q, Naval Sea Systems Command, 2531 Jefferson Davis Hwy, Arlington, VA 22242-5160 by using the Standardization Document Improvement Proposal (DD Form 1426) appearing at the end of this document or by letter.

2.2 Government documents.

2.2.1 Specifications, standards, and handbooks. The following specifications, standards, and handbooks form a part of this document to the extent specified herein. Unless otherwise specified, the issues of these documents are those listed in the issue of the Department of Defense Index of Specifications and Standards (DoDISS) and supplement thereto, cited in the solicitation (see 6.2).

SPECIFICATIONS

FEDERAL

A-A-203 - Paper, Kraft, Untreated.
 A-A-1894 - Paper, Kraft, Treated (Fire Resistant).
 A-A-1898 - Cushioning Material, Cellulosic, Packaging.
 P-D-680 - Dry Cleaning and Degreasing Solvent.
 VV-L-800 - Lubricating Oil, General Purpose, Preservative (Water-Displacing, Low Temperature).
 PPP-B-566 - Boxes, Folding, Paperboard.
 PPP-B-585 - Boxes, Wood, Wirebound.
 PPP-B-601 - Boxes, Wood, Cleated-Plywood.
 PPP-B-621 - Box, Wood, Nailed and Lock-Corner.
 PPP-B-665 - Boxes, Paperboard, Metal Edged and Components.
 PPP-B-676 - Boxes, Setup.
 PPP-B-1055 - Barrier Material, Waterproofed, Flexible.
 PPP-C-1120 - Cushioning Material, Uncompressed Bound Fiber for Packaging.

DEPARTMENT OF DEFENSE

MIL-C-104 - Crates, Wood; Lumber and Plywood Sheathed, Nailed and Bolted.
 MIL-B-121 - Barrier Material, Greaseproofed, Waterproofed, Flexible.
 MIL-S-196 - Support Items, Accessories, and Kits, Mechanical; Packaging of.
 MIL-P-197 - Packaging of Bearings, Antifriction; Associated Parts and Subassemblies.
 MIL-B-233 - Box, Repair Part, Storage.
 MIL-B-3106 - Board, Composition, Water-Resistant, Solid (for Filler or Cushioning Pads).
 MIL-P-3420 - Packaging Materials, Volatile Corrosion Inhibitor, Treated, Opaque.
 MIL-C-3774 - Crates, Wood; Open, 12,000- and 16,000-Pound Capacity.
 MIL-R-5001 - Rubber Cellular Sheet, Molded and Hand-Built Shapes; Latex Foam.
 MIL-R-6130 - Rubber, Cellular, Chemically Blown.
 MIL-C-6799 - Coatings, Sprayable, Strippable, Protective, Water Emulsion.
 MIL-C-9897 - Crates, Slotted Angle, Steel or Aluminum, for Lightweight Airframe Components and Bulky Items (for Maximum Loads of 1363 Kgs (3000 Pounds)).
 MIL-L-10547 - Liners, Case, and Sheet, Overwrap; Water-Vaporproof or Water-proof, Flexible.
 MIL-PRF-16173 - Corrosion Preventive Compound, Solvent Cutback, Cold-Application.
 MIL-P-16789 - Pumps (Including Prime Movers and Support Items); Packaging of.
 MIL-E-17555 - Electronic and Electrical Equipment, Accessories, and Provisioned Items (Repair Parts): Packaging of.
 MIL-PRF-20092 - Rubber or Plastic Sheets and Assembled and Molded Shapes,

- Synthetic, Foam or Sponge, Open Cell.
- MIL-B-22019 - Barrier Materials, Transparent, Flexible, Sealable, Volatile Corrosion Inhibitor Treated.
- MIL-B-22020 - Bags, Transparent, Flexible, Sealable, Volatile Corrosion Inhibitor Treated.
- MIL-T-22085 - Tapes, Pressure-Sensitive, Adhesive, Preservation and Sealing.
- MIL-I-22110 - Inhibitor, Corrosion, Volatile, Crystalline Powder.
- MIL-B-22191 - Barrier Material, Transparent, Flexible, Heat-Sealable.
- MIL-C-23760 - Coating, Sprayable, Strippable, Protective, for Packaging of Weapons Systems and eComponents: Application of.

DEPARTMENT OF DEFENSE

- MIL-STD-129 - Standard Practice for Military Marking.
- MIL-STD-758 - Packaging Procedures for Submarine Support Items.
- MIL-STD-2073-1C - Standard Practice for Military Packaging.

HANDBOOKS

DEPARTMENT OF DEFENSE

- MIL-HDBK-129 - Handbook for Military Marking.

(Unless otherwise indicated, copies of the above specifications, standards, and handbooks are available from the Standardization Document Order Desk, Defense Automated Printing Service (DAPS), 700 Robbins Avenue, Building 4D, Philadelphia, PA 19111-5094.)

2.2.2 Other Government documents, drawings, and publications. The following other Government documents, drawings, and publications form a part of this document to the extent specified herein. Unless otherwise specified, the issues are those cited in the solicitation.

DOCUMENTS

NAVAL SEA SYSTEMS COMMAND (NAVSEA)

- S9245-AR-TSM-010/PROP Technical Manual, Marine Propeller Inspection, Repair and Certification.

(Applications for copies should be addressed to the Standardization Documents Order Desk, Defense Automated Printing Service (DAPS), Building 4D, 700 Robbins Avenue, Philadelphia, PA 19111-5094.)

PUBLICATIONS

DEPARTMENT OF LABOR (OSHA)

- Code of Federal Regulations (CFR),
29 CFR, Part 1910, Sections 145
and 1001 - Hazard Communication Standards.

(Application for copies should be addressed to the Superintendent of Documents, US Government Printing Office, Washington, DC 20402.)

2.3 Non-Government publications. The following document(s) form a part of this document to the extent specified herein. Unless otherwise specified, the issues of the documents which are DoD adopted are those listed in the issue of the DoDISS cited in the solicitation. Unless otherwise specified, the issues of documents not listed in the DoDISS are the issues of the documents

cited in the solicitation (see 6.2).

AMERICAN NATIONAL STANDARDS INSTITUTE (ANSI)

- ANSI Z1.4 - Sampling Procedures and Tables for Inspection by Attributes. (DoD adopted)

(Application for copies should be addressed to the American National Standards Institute, Inc., 11 West 42nd Street, 13th Floor, New York, NY 10036.)

AMERICAN PLYWOOD ASSOCIATION (APA)

- APA PS-1 - Construction and Industrial Plywood.

(Application for copies should be addressed to the American Plywood Association, U.S. Headquarters and International Marketing Division, 7011 South 19th Street, PO Box 11700, Tacoma, WA 98411-0700.)

AMERICAN SOCIETY FOR TESTING AND MATERIALS (ASTM)

- ASTM D 1974 - Standard Practice for Methods of Closing, Sealing, and Reinforcing Fiberboard Boxes.
- ASTM D 3951 - Standard Practice for Commercial Packaging. (DOD adopted)
- ASTM D 4376 - Standard Specification for Vapor-Degreasing Grade Perchloroethylene.
- ASTM D 5118 - Standard Practice for Fabrication of Fiberboard Shipping Boxes.
- ASTM D 5168 - Standard Practice for Fabrication and Closure of Triple-Wall Corrugated Fiberboard Containers.
- ASTM D 5486 - Standard Specification for Pressure-Sensitive Tape for Packaging, Box Closure, and Sealing.
- ASTM D 6039 - Crates, Wood, Opened and Covered. (DoD adopted)
- ASTM D 6251 - Standard Specification for Wood-Cleated Panelboard Shipping Boxes.

(Application for copies should be addressed to the American Society for Testing and Materials, 100 Barr Harbor Drive, West Conshohocken, PA 19428-2959.)

AMERICAN WOOD PRESERVERS' ASSOCIATION (AWPA)

- AWPA C1 - All Timber Products, Pressure Treatment.
- AWPA C2 - Lumber, Timbers, Bridge Ties and Mine Ties, Pressure Treatment.
- AWPA C9 - Plywood, Pressure Treatment.

(Application for copies should be addressed to American Wood Preservers' Association, 3246 Fall Creek Highway, Suite 190, Granbury, TX 76049-7979.)

ASSOCIATION OF AMERICAN RAILROADS (AAR)

Association of American Railroads Rules.

(Application for copies should be addressed to the Association of American Railroads, American Railroads Building, 50 F Street, NW, Washington, DC 2001-1564.)

2.4 Order of precedence. In the event of a conflict between the text of this document and the references cited herein, the text of this document takes precedence. Nothing in this document, however, supersedes applicable laws and

regulations unless a specific exemption has been obtained.

3. REQUIREMENTS

3.1 First article. When specified (see 6.2), a sample shall be subjected to first article inspection in accordance with 4.2.

3.2 Definitions or explanation of packaging terms. Definitions or explanation of packaging terms applicable to this specification shall be as defined in the applicable referenced specification (see 6.4).

3.3 Materials. Packaging materials shall be as specified herein and in the applicable referenced specifications.

3.3.1 Recycled, recovered, or environmentally preferable materials. Recycled, recovered, or environmentally preferable materials should be used to the maximum extent possible provided that the material meets or exceeds the operational and maintenance requirements, and promotes economically advantageous life cycle costs.

3.3.2 New materials. The use of newly developed packaging materials or procedures is encouraged and recommended and will be permitted under the conditions specified herein, provided they are equal to or better than the specified materials or procedures.

3.3.2.1 Certification of new materials. Materials or procedures other than those specified herein shall equal or exceed the requirements specified herein. If, after a review of the material or procedure and the related documented evidence, or the witnessing of the stipulated tests, it is the opinion of the contracting activity that the material or procedure meets or exceeds the requirements specified herein, authorization for use will be granted.

3.3.3 Asbestos.

3.3.3.1 Packaging material. Asbestos or material and items containing asbestos shall not be used in the packaging of material covered by this specification (see 6.5).

3.3.3.2 Packaged items. Asbestos and separately packaged components containing asbestos shall be packaged in sealed, dust, and siftproof packages. Flexible packages shall be heat sealed.

3.3.3.3 Dusting material. Talc or talcum, when used in the packaging process, for example, dusting of items, shall be asbestos-free.

3.3.4 Cushioning and wrapping materials. The use of excelsior, newspaper, shredded paper (all types) and similar hygroscopic or nonneutral materials, and all types of loose fill materials for applications such as cushioning, fill, stuffing, and dunnage is prohibited.

3.4 Technical information. Complete descriptive packaging details on drawings, test results, and packaging, and transportation data requirements are not required when such were previously approved by the contracting activity.

3.5 Levels of protection.

3.5.1 Preservation. Unless otherwise specified (see 6.2), preservation shall be level A as specified in 3.5.1.1 (see 6.4.1).

3.5.1.1 Level A. Cleaning, drying, preservatives, preservative application criteria, and methods of preservation (unit protection) shall be in accordance with MIL-STD-2073-1C (military preservation), and as specified herein. Requirements in table I are assigned by item; methods of unit protection are assigned on the basis of the type of unit protection most commonly required for a specific component or item. The preservation activity may provide any additional protection that is considered necessary with the prior approval of the contracting activity.

TABLE I. Preservation.

| Item | Preservatives | Method of preservation (MIL-STD-2073-1C) | Remarks |
|--|---|--|-----------------------------|
| Accessories | | | See 3.7.2.7 and 3.14.3 |
| Sleeves shrunk on shaft | | | See 3.15.2 |
| Certification form for propeller | | | See 3.14.5 |
| Devices | | | See 3.14.8 |
| Electrical and electronic items | | | See 3.7.2.5 and MIL-E-17555 |
| Finished machined: | | | |
| Steel shaft surfaces | | | See 3.15.2 |
| Bronze shafts | | | See 3.15.2 |
| Nickel-copper alloy shafts | | | See 3.15.2 |
| Full molded rubber or laminated phenolic | None | Method 10 | |
| Line shaft and main thrust bearings | MIL-PRF-16173, GR 3 | Method 20 | See 3.7.2 and 3.7.3 |
| Technical manuals | None | Method 10 | See 3.10 |
| Miscellaneous finished bronze, brass, and nickel-copper alloy castings (stern tube stuffing box and gland) | None | Method 10 | |
| Miscellaneous finished forged and rolled brass, bronze and nickel-copper alloy parts (studs, rings, and keys) | None | Method 10 | See 3.7.2.3 |
| Miscellaneous finished forged and rolled steel parts (coupling bolts, nuts, washers, keys, and coupling flanges) | MIL-PRF-16173, GR 1 MIL-PRF-16173, GR 4 or MIL-P-3420 MIL-B-22019 MIL-B-22020 MIL-I-22110 | Method 20 or Method 30 | |
| Miscellaneous finished steel and iron castings bulkhead stuffing box | MIL-PRF-16173, GR 1 MIL-PRF-16173, GR 4 or MIL-P-3420 MIL-B-22019 MIL-B-22020 MIL-I-22110 | Method 20 or Method 30 | |

TABLE I. Preservation - Continued.

| | | | |
|--|--|--|---------------------------|
| Propeller fairwater caps | | | See 3.14.9 |
| Propeller gauges | | | See 3.17 & figure 18 |
| Item | Preservatives | Method of preservation (MIL-STD-2073-1C) | Remarks |
| Propellers, fixed pitch Ship | | | See 3.14 |
| Boat | | | See 3.14.1.3 |
| Propellers, controllable pitch | | | See 3.14 |
| Built up and controllable pitch propeller hubs | | | See 3.16 |
| Pumps | | | See 3.7.2.6 |
| Roller and ball bearings | | | See MIL-P-197 |
| Rough machined steel shaft forgings | MIL-PRF-16173, GR 1 MIL-PRF-16173, GR 4 | | |
| Repair parts (support items and accessories) | | | See 3.7.2.7 and MIL-S-196 |
| Fiberglass - covered shaft areas | | | See 3.15.4 |
| Stern tube and strut bearing bushings | None | Method 10 | |
| Stern tube and strut bearing staves: | | | ¹ - |
| Laminated phenolic | None | Method 10 | |
| Rubber, brass backed | None | Method 10 | |
| Tube from stern tube and strut bearings | None | Method 10 | |
| Plug and ring gauges | | | See 3.18 |

¹ Rubber items and surfaces covered with rubber shall be covered with an opaque or kraft wrapping paper in accordance with A-A-203 or A-A-1894, type and style optional, to prevent direct exposure to sunlight.

3.6 Disassembly, matchmarking, and lubrication.

3.6.1 Disassembly. System, equipment, or item disassembly shall be the minimum necessary to make accessible for cleaning, drying, and preservation of equipment and its critical surfaces. Removal of secondary assemblies, accessories, or projecting parts which will facilitate protection of the equipment or item from damage, pilferage, loss, or reduction of cube is permitted where such removal will not affect permanent settings or alignments, and where the removed items can be readily reassembled at the installation site without the need for special tools or gauges. Removed hardware (bolts, nuts, pins, screws, washers, and others) shall be reinstalled in the mating parts and secured to prevent loss. Removed items or parts shall be packaged to the same level of protection as the basic or prime equipment.

3.6.2 Matchmarking. Removed parts or items shall be matchmarked to facilitate reassembly. Removed parts or items shall be tagged and marked and the tags shall be attached to each mating part or item. The tags and printing thereon shall be resistant to water, oil, and fading.

3.6.3 Lubrication. Rotating joints, bearings, and similar moving parts shall be thoroughly lubricated. The lubricant shall be as specified in the equipment specification or as approved by the contracting activity. Excess lubricants shall be removed before packing operations.

3.7 Preservation. Preservation shall be level A or commercial, as specified (see 6.2).

3.7.1 Cleaning and drying. Unless otherwise specified herein, items shall be cleaned and dried by any suitable process or processes which are not injurious to the item or as specified herein.

3.7.2 Preservation. Immediately after product cleaning and drying, surfaces of the equipment or part shall be treated with a preservative as specified in table I, or as specified herein. During and after preservative application, the product shall be handled in such a manner as to produce a uniform protective film. The protective film shall remain untouched for a period of time to allow the film to set before wrapping and packing are undertaken. Preservative shall not be applied to items or surfaces which are vulnerable to damage by the preservative and in accordance with MIL-STD-2073-1C. Excessive use of preservatives shall be avoided.

3.7.2.1 External metal surfaces. Items shall be preserved as specified in table I. Preservatives for external metal surfaces shall be in accordance with MIL-STD-2073-1C. The use of preservatives in accordance with MIL-PRF-16173, grades 1 and 4 shall be limited to surfaces where it will not have to be removed to place the equipment in operation, or where its removal by scraping or solvent action would not damage the part or equipment.

3.7.2.2 Internal metal surfaces. Internal metal surfaces which normally are in contact with oil shall be coated with a preservative in accordance with MIL-PRF-16173, grade 2. Internal metal surfaces normally in contact with water shall be coated with a preservative in accordance with MIL-PRF-16173, grade 3 or MIL-PRF-16173, grade 5. The MIL-PRF-16173, grade 5 preservative shall be used when chemical boil-out cannot be used for compound removal, or where removal by hot water or steam is desired.

3.7.2.3 Finished machined surfaces. Unless otherwise specified herein, external finished machined steel surfaces protected with a preservative (see table I) shall be wrapped with barrier material in accordance with MIL-B-121, type I, grade A, class 2, followed by an overwrap with type I, grade C, class 1 or 2, with class selection at the activities option.

3.7.2.4 Closure of openings. Unless otherwise specified herein, openings shall be sealed with tape in accordance with ASTM D 5486, or a minimum 0.004 inch thick polyethylene film secured with tape as specified herein. When the covering is vulnerable to damage (puncture, tearing, and so forth) the covering shall be further protected by use of weather-resistant hardboard, wood, plywood, or metal covers. Pipe and fitting ends may be sealed with metal or plastic caps or plugs.

3.7.2.5 Electrical and electronic equipment. Preservation, packing, and marking shall be in accordance with MIL-E-17555.

3.7.2.6 Pumps and associated parts. Preservation, packing, and marking shall be in accordance with MIL-P-16789.

3.7.2.7 Accessories and detached parts. Unless otherwise specified herein, accessories and detached parts shall be preserved as specified in table I. Except as specified in table I, and in order to facilitate packaging, accessories such as thermometers, sight glasses, and route connectors shall be individually preserved in accordance with MIL-S-196 or the applicable component specification. Unless otherwise specified (see 6.2), accessories accompanying equipment, preserved as specified herein, shall be packed in separate containers and secured within the complete or main (number

one) equipment container. Consolidation of accessories and detached parts in common shipping containers shall be applied where feasible.

3.7.2.8 Incorporated equipment. For systems, assemblies, and components acquired for incorporation into a ship or assembly prior to delivery to the Government, the requirements of this specification do not apply. In lieu thereof, preservation, packing, and marking of these systems, assemblies, or components shall be sufficient to provide protection from damage and deterioration until incorporation.

3.7.3 Bearings. Ball or roller bearings shall be preserved in accordance with MIL-P-197. Lubricating systems, sleeve bearings (except prelubricated bearings), and housings shall be flushed with a preservative in accordance with MIL-PRF-16173, grade 2 and thoroughly drained. Surfaces of sleeve bearings and journals shall receive a preservative coating. Barrier material in accordance with type I, grade A, class 2 of MIL-B-121 shall be used between the upper half linings of split sleeve bearings and journal to prevent vertical movement of the shaft or rotor after the bearing caps have been seated and bolted in place. The barrier material shall be projected beyond the assembly to permit easy detection. Each journal so prepared shall be plainly marked with a suitable waterproof tag marked with the following:

"BEFORE OPERATING MACHINE, REMOVE BARRIER MATERIAL BETWEEN THE JOURNAL AND UPPER HALF LINING".

3.7.4 Repair parts and tools (accompanying equipment or for stock). Repair parts and tools shall be cleaned, preserved, and packaged as specified in table I, except as specified herein. Unless otherwise specified (see 6.2), repair parts and tools shall be packaged one part per unit package, except that all parts comprising a single set or assembly shall be packaged together. When unit is packaged as a set, assembly, or in quantities greater than one, each item shall be wrapped or cushioned to prevent direct surface contact with the surface of adjacent parts.

3.7.4.1 Other repair parts. Repair parts not specifically covered in table I shall be cleaned, preserved, and packaged as specified (see 6.2).

3.7.4.2 Submarine repair parts. Repair parts for submarine usage shall have special reduced cube packaging in accordance with MIL-STD-758.

3.7.4.3 Special tools. Special tools shall be cleaned, preserved, and packaged in accordance with MIL-STD-2073-1C as follows:

- (a) Tools made of ferrous metal with non-critical surfaces shall be cleaned as specified in 3.7.1, dried as required, coated with a preservative in accordance with MIL-PRF-16173, grade 2, and packaged in accordance with method 20 of MIL-STD-2073-1C. In lieu of the greaseproof wrap required, tools may be wrapped in transparent flexible greaseproof film in accordance with type II of MIL-B-22191.
- (b) Tools made of ferrous metal with critical surfaces shall be cleaned as specified in 3.7.1, dried as required, coated with a preservative in accordance with VV-L-800, and packaged in accordance with method 30 of MIL-STD-2073-1C. Selection of method 31, 32 and 33 shall be at the activity's option. Transparent flexible greaseproof film in accordance with type II of MIL-B-22191 may be used in lieu of wrapping material in accordance with MIL-B-121 for a preliminary wrap.
- (c) Tools fabricated completely of non-ferrous materials or ferrous materials that are plated or otherwise treated to resist corrosion shall be packaged in accordance with method 10 of MIL-STD-2073-1C.

3.7.5 Unit and intermediate containers. Unit containers, except those required in accordance with MIL-STD-2073-1C for the applicable method of preservation, and intermediate containers shall be folding paperboard, fiberboard, paperboard, metal stayed or set-up paperboard boxes in accordance with PPP-B-566, PPP-B-665, PPP-B-676, or ASTM D 5118 at the option of the preserving activity. The gross weight of paperboard boxes shall be not greater than 10 pounds. Fiberboard boxes shall be not greater than 20 pounds. Unless otherwise specified (see 6.2), box closure shall be as specified in the applicable box specification or appendix thereto except that box closure for ASTM D 5118 shall be in accordance with ASTM D 1974. When the gross weight is greater than 20 pounds, unit and intermediate containers shall conform to the containers specified in 3.8 for the level specified subject to the limitations specified herein.

3.7.6 Repair parts boxes. Unless otherwise specified (see 6.2), repair parts boxes shall not be required. When required, on board repair parts shall be packed in type M (steel) or type W (nonmagnetic) repair parts boxes in accordance with MIL-B-233, as specified (see 6.2).

3.7.7 Index listing of repair parts and tools. An index list of repair parts and tools shall be inserted in each shipping container containing repair parts. The list shall be inserted in the index list support located on the interior side of the repair parts box cover, or shall be placed within the box for quick accessibility. The list shall give a complete itemized list of the container contents including stock numbers, nomenclatures, and quantities. The list shall be enclosed in a waterproof bag or shall be so treated as to be resistant to water, oil, and fading.

3.7.8 Cushioning and wrapping materials. Equipment or parts shall be cushioned, as required, to prevent damage to the item as specified in MIL-STD-2073-1C, and to prevent puncture or tearing of the barrier materials used in packaging. Excessive use of cushioning within the unit package shall be avoided since an unnecessary increase in tare weight and cube will otherwise result. Cushioning materials which have not been chemically refined for noncorrosiveness shall only be used when contained in a sealed waterproof barrier in accordance with PPP-B-1055. Cushioning materials used within the unit pack shall conform to any of, or combination of, the following specifications, at the contractor's option, which will provide the required protection:

| <u>Specifications</u> | <u>Materials</u> | <u>Special requirements</u> |
|---------------------------|---|---|
| A-A-1898 PPP-C-1120 | Cellulosic Bound fiber | For Navy, use class A, grade 1, type optional |
| A-A-203 A-A-1894 | Paper, kraft, untreated Paper, kraft, treated (fire- resistant) | |
| MIL-B-3106 | Board, composition, water- resistant, solid | |
| MIL-R-5001 | Rubber, latex foam | For Navy, use grade A, type and class optional |
| MIL-R-6130 MIL-R-20092 | Rubber, cellular Rubber sheets and assembled and molded shapes, cellular, synthetic, open cell | For Navy, use grade A For Navy, use class 5 |

3.7.9 Barrier materials. When using barrier materials in accordance with MIL-B-121, the following precautions shall apply:

- (a) The greaseproof side of grade A materials shall be in contact with the part or surface.

- (b) Grade C material shall not be in contact with metal surfaces or be used as an intimate wrap.

3.7.10 Commercial. Commercial preservation of equipment, accessories, components, and repair parts shall be in accordance with ASTM D 3951.

3.8 Packing. Packing shall be level A or commercial, as specified (see 6.2).

3.8.1 Level A.

3.8.2 General requirements. Shipping containers shall be of similar construction, of uniform size, and of minimum cube and tare consistent with required protection. Special tools, when furnished, shall be packed with the equipment for which they are intended. Contents of the shipping container shall fit so the packed unit forms a compact, nonshifting load. Wood, plywood, or wood-cleated boxes shall be modified by the addition of skids. Unless otherwise specified herein, application of skids shall be in accordance with PPP-B-601, PPP-B-621, or the applicable crate specification when used. Except where otherwise specified herein, crates shall be used for the shipment of individual items exceeding the weight limitations of the wood, plywood, or wood-cleated boxes. Unless otherwise specified (see 6.2), selection of the shipping container shall be at the packaging activity's option. The reference preservation, packing, and car loading figures herein are intended for general guidance use. Wherever reference is made to wood, wood sheathing, or wood boxes, plywood sheathing (see 3.8.2.2) and plywood boxes in accordance with PPP-B-601 are acceptable alternates.

3.8.2.1 Anchoring, blocking, bracing, and cushioning. Except as otherwise specified herein, equipment, accessories, and repair parts shall be anchored, blocked, braced, and cushioned, as applicable, in accordance with the appendix to the applicable container specification. Cushioning materials shall conform to materials specified in 3.7.8.

3.8.2.2 Wood and plywood containers.

3.8.2.2.1 Plywood. Plywood sheathing, including container tops (crates), shall be in accordance with APA PS-1. Unless otherwise specified (see 6.2), plywood selection for container use shall be as follows:

- (a) Multiple trip containers. - Multiple-trip plywood containers (see 6.4.2) shall be in accordance with APA PS-1, minimum grade A-C, preserved as specified in 3.8.2.2.2.1, or in accordance with APA PS-1, marine grade.
- (b) Single trip containers. - Single-trip plywood containers shall be in accordance with APA PS-1, exposure 1, minimum grade C-D.

3.8.2.2.2 Multiple-trip containers. Containers including interior packing media shall be fabricated and assembled to certify re-use. Unless otherwise specified herein for wood or plywood boxes, the box cover (sides, ends, and top) may be assembled and fastened with nails; however, the assembled cover shall be fastened to the container platform or base by screws or bolts. Additional guidance for the application, selection, and spacing requirements for fasteners is contained in the applicable container specification.

3.8.2.2.2.1 Preservative treatment for multiple-trip containers. Unless otherwise specified (see 6.2), all multiple-trip (reusable) containers and all of the finished wood or plywood members and parts shall be preserved in accordance with AWPA C1 and C2 for lumber and AWPA C9 for plywood, for "above ground use". When containers are painted, preservation shall be accomplished

prior to the painting application. Fasteners (nails, bolts, screws, washers, nuts, and so forth) for containers treated as specified herein shall be galvanized or corrosion treated unless otherwise specified. Cut ends of lumber or plywood that are untreated shall be preserved by coating untreated ends with a copper-napthanate solution.

3.8.2.3 Stern tube and strut bearing. Bearings or bearing staves shall be packed in wood or wood-cleated plywood boxes in accordance with PPP-B-621, class 2, or PPP-B-601, overseas type, respectively, at the packaging activity's option. Full molded or stave bearings not greater than 90 pounds need not be strapped and shall be packed in wood-cleated panelboard boxes in accordance with ASTM D 6251, class II. Staves greater than 1000 pounds shall be packed in sheathed or covered crates in accordance with MIL-C-104, type I, class 1 or 2, or ASTM D 6039. Unless otherwise specified (see 6.2), selection of the crate type and style shall be at the packaging activity's option.

3.8.2.4 Line shaft and thrust bearings. Oil and grease lubricated line shaft and thrust bearings of the conventional roller, ball, or babbitt type shall be packed in containers as specified in 3.8.2.5.

3.8.2.5 Associated repair parts. Associated repair parts shall be packed in containers in accordance with any one of the following specifications at the option of the packaging activity:

| <u>Specification</u> | <u>Container</u> | <u>Type or class</u> |
|----------------------|--|-------------------------|
| PPP-B-585 | Wood, wirebound | Class 3 |
| ASTM D 6251 | Panelboard, wood-cleated | Class weather-resistant |
| ASTM D 5118 | Fiberboard | Weather-resistant |
| ASTM D 5168 | Fiberboard, corrugated, triple-wall | Class 2 |
| MIL-C-104 | Crates, wood, lumber, and plywood sheathed | |
| MIL-C-3774 | Crates, wood, open | |
| ASTM D 6039 | Crates, wood, open and covered | |

Shipping containers, except ASTM D 5118 fiberboard boxes, shall be closed and reinforced in accordance with the applicable container specification or appendix thereto. ASTM D 5118 fiberboard boxes shall be closed in accordance with sealing method B or C of ASTM D 1974. The gross weight of wood or wood-cleated boxes shall be not greater than 200 pounds, except when a single item exceeds 200 pounds. Fiberboard boxes shall not exceed the weight limitations of the applicable fiberboard box specifications. Shipping containers, except crates and ASTM D 5118 fiberboard boxes, shall have caseliners in accordance with MIL-L-10547. Caseliners shall be closed in accordance with MIL-L-10547. Barrier material in accordance with MIL-B-121 may be used to fabricate the caseliner. Caseliners are not required when boxes are packed with items or interior packages meeting the following:

- (a) Items which are completely painted and have no unprotected critical surfaces
- (b) Large items which are completely coated with a preservative in accordance with MIL-PRF-16173, grades 1 or 4, with critical interior item surfaces preserved and all openings sealed with authorized material
- (c) Method 30 or 40 packages, in accordance with MIL-STD-2073-1C
- (d) Interior packages which conform to weather-resistant types or classes and are waterproofed in accordance with the applicable interior package container specification.

3.8.2.6 Repair parts boxes. Repair parts boxes in accordance with MIL-B-233 (see 3.7.6) shall be overpacked in containers as specified in 3.8.2.5. The gross weight of parts shall be not greater than 200 pounds in any

one box. Where the combined weight of a set is greater than 200 pounds, such parts shall be grouped and packed in two or more boxes numbered consecutively to show the number of boxes in a complete set. Unless otherwise specified (see 6.2), an exception will be made when an individual part weight is greater than 200 pounds, in which case the part shall be packed in an individual repair parts box.

3.8.2.7 Commercial packing. Equipment preserved as specified in 3.7.10 shall be packed in accordance with ASTM D 3951.

3.9 Marking. In addition to any special marking required (see 6.2), level A interior (unit and intermediate) packages and exterior shipping containers shall be marked for shipment in accordance with MIL-STD-129 / MIL-HDBK-129 except that wood containers shall be stenciled in all capital letters. A contrasting color oil based paint shall be applied to the wood surface prior to stenciling. Commercial packages and shipping containers shall be marked in accordance with ASTM D 3951.

3.10 Technical manuals. Manuals which accompany shipments shall be packaged in transparent, waterproof, plastic bags not less than 4 mils thick and heat sealed. Manuals, when shipped in bulk quantities, shall not be individually wrapped, but shall be packed in accordance with the requirements of the applicable manual specification or packed in containers in accordance with the requirements for the level specified. Shipment of equipment which includes technical data shall have the location of the information annotated on the packing list. In addition, the shipping container housing the manuals shall be marked "MANUALS ENCLOSED".

3.11 Air shipment. Items required for movement by air shipment shall be handled for transportability in accordance with the procedures specified by the Air Mobility Command Air Base receiving the item for airlift.

3.12 Asbestos items. An asbestos caution label shall be affixed to each interior (unit and intermediate) and exterior pack. The caution label shall be in accordance with 29 CFR, part 1910, sections 145 and 1001 (yellow background with black letters). The caution label shall state the following:

"CAUTION
Contains Asbestos Fibers.
Avoid Creating Dust.
Breathing Asbestos Dust May
Cause Serious Bodily Harm".

3.13 Workmanship. Workmanship shall be so that, when the proper procedures are followed, materials and equipment being processed, cleaned, preserved, packed, and marked will receive protection against corrosion and deterioration during shipment and prolonged periods of storage, and will require minimum reprocessing for service for further storage.

3.14 Propellers.

3.14.1 Propeller preservation. Propellers are categorized as monobloc and built up blades. Built up blades may be of the controllable-pitch (CP) type. The requirements for ready for issue (RFI) propellers and not ready for issue (NRFI) propellers are identical except as specified herein. Preservation for propellers shall be level A as specified in this specification unless otherwise specified. Alternate methods for propeller preservation may be utilized with the prior approval of the contracting activity. Propellers shall be cleaned in accordance with NAVSEA S9245-AR-TSM-010/PROP. Prior to preservation, monobloc propellers shall have the forward and aft faces protected as specified below.

3.14.1.1 Air emission system. Prior to the application of strippable compound, ships' propellers incorporating an air emitter system shall have the air inlet and air emitter openings covered with minimum 3/4-inch wide pressure sensitive tape in accordance with MIL-T-22085, type II. The tape shall be centered over the air emitter holes. Acrylic or transparent protective coatings or coverings shall not be applied in lieu of tape.

3.14.1.2 Closure of hub openings. Monobloc propeller bore openings equal to or less than 12 inches shall be sealed with tape in accordance with MIL-T-22085, type II or a minimum 0.004 inch thick polyethylene film secured with tape as specified herein. When the covering is vulnerable to damage (puncture, tearing, and so forth.) the covering shall be further protected by use of weather-resistant hardboard, wood, plywood, or metal covers. Pipe and fitting ends shall be sealed with metal or plastic caps or plugs. Monobloc propellers with bore openings greater than 12 inches shall be closed as specified below.

3.14.1.2.1 Forward end closure. The forward end of the propeller hub shall be fitted with a 0.75-inch thick, marine grade plywood in accordance with APA PS-1, disk held in place with hex head bolts. Bolt heads shall be countersunk into the plywood disk. The outer diameter of the disk shall be equal to the outside diameter of the hub forward face. The inner diameter of the disk shall be 0.5 inches larger than the bore at the hub forward face. The forward end closure shall be reusable. A single layer of barrier material in accordance with MIL-B-121, type I, grade A, class 2 shall be placed between the wood disk and propeller.

3.14.1.2.2 Aft end closure. The aft end of the hub shall be fitted with a thick steel plate attached to the hub aft face with hex head bolts. The plate shall be machined with a step that will fit into the aft face counterbore. The plate thickness shall be a minimum of 0.375 inch thick but of suitable size to resist deflection during transportation of the propeller on a tilt-type fixture. The plate outer diameter shall be equal to the outside diameter of the hub aft face and the inner diameter shall be 6 inches. Cut outs shall be provided in the steel plate to permit shouldering the eyebolts. A minimum of two eyebolts shall be installed in the aft face, 180 degrees apart. The aft end closure shall be reusable. A single layer of barrier material in accordance with MIL-B-121, type I, grade A, class 2 shall be placed between the metal disk and propeller.

3.14.1.2.2.1 Long term protection. For storage longer than 60 days, the center holes in the plywood disk and steel plate shall be covered with 0.75-inch thick marine grade plywood in accordance with APA PS-1, of sufficient diameter to cover the hole. The plywood covers shall be bolted with hex head bolts to the plywood disk and steel plate. The bolts shall be countersunk into the plywood disk. The peripheral joints between the plywood disk, steel plate, plywood covers, and hub faces shall be covered with tape in accordance with MIL-T-22085, type II. The tape and center plywood covers may be removed at the time of shipment if the propeller is to be shipped utilizing a propeller shipping frame (see figure 1). After shipment, the tape and plywood covers shall be replaced.

3.14.1.2.2.2 Short term protection. For temporary protection of less than 60 days, the center hole in the plywood disk and steel plate shall be covered with tape in accordance with MIL-T-22085, type II. The tape may be removed at the time of shipment if the propeller is to be shipped utilizing a propeller shipping frame (see figure 1). After shipment, the tape shall be replaced.

3.14.1.2.3 CP blade palm protection. The bottom of CP blade palms shall be covered with barrier material in accordance with MIL-B-121, type I, grade A, class 2. A marine grade plywood disk of 3/8 thickness shall then be applied to the CP blade palm and secured by bolting with corrosion resistant (stainless steel) hex head bolts through the CP blade bolt holes. Marine grade plywood washers shall be inserted into the top of the corresponding CP blade bolt holes. Barrier material in

accordance with MIL-B-121, type I, grade A, class 2 shall be placed between the washers and the blade palm.

3.14.1.3 Preservative application. Screw slots, holes, other machined attributes, or sharp edges shall be covered with tape in accordance with MIL-T-22085, type II to prevent the preservative from spanning gaps. Monobloc and CP propellers shall be coated with a strippable compound which shall be in accordance with MIL-C-6799, type II, multi-coat system. The coating shall be applied directly, except as otherwise specified herein, to the propeller. The finished coat system shall consist of three separately applied coats in the following order: black, gray, and a white top coat, having a 12- to 15-mil total dry film thickness. The material can be sprayed, brushed, or rolled in passes to a 4- to 5-mil dry thickness per coat without sagging. The compound application shall be in accordance with MIL-C-23760. In no case shall a white coat be applied as the first coat. Unless otherwise specified (see 6.2), propellers less than 30 inches in diameter shall be preserved with material in accordance with MIL-PRF-16173, grade 4. NRFI propellers shall be coated with a single black coat of preservative. An acrylic or transparent protective coating or covering shall be applied over the stamped propeller identification markings to maintain these markings in a fully visible and readily readable condition after further preservation. Edges of the preservative adjacent to the stamped hub or palm data shall be sealed with an acrylic coating or tape conforming to MIL-T-22085, type II.

3.14.1.3.1 Alternate procedure - strippable compound. Screw slots, holes, other machined attributes, or sharp edges shall be covered with tape in accordance with MIL-T-22085, type II to prevent the preservative from spanning gaps. The strippable compound shall be in accordance with MIL-C-6799, type II, multi-coat system. Except as otherwise specified herein, the coating shall be applied directly to the propeller. The finished coat system shall consist of two separately applied coats in the following order: type II, class 1 black, and type II, class 5 white top coat, having a 12- to 25-mil total dry film thickness. The material may be sprayed or brushed on in passes to a 4- to 5-mil dry thickness per coat without sagging or runs. The compound application shall be in accordance with MIL-C-23760. In no case shall a white coat be applied as the first coat. NRFI propellers shall be coated with a single black coat of preservative. An acrylic or transparent protective coating or covering shall be applied over the stamped propeller identification markings to maintain these markings in a fully visible and readily readable condition after further preservation. Edges of the preservative adjacent to the stamped hub or palm data shall be sealed with an acrylic coating or tape conforming to MIL-T-22085, type II.

3.14.1.4 Propeller blade edge guards. Blade edge (including tips) guards shall be applied over the protective coating and be applicable only to propellers greater than 60 inches in diameter, and less than 60 inches in diameter when the propellers are not crated. Prior to edgeguard application, the edge of each propeller blade shall be completely covered with at least two thicknesses of not less than 8-ounce canvas, or cloth reinforced rubber of 0.187-inch thickness. Blade tips of class 1 propellers identified in accordance with NAVSEA S9245-AR-TSM-010/PROP shall have cloth reinforced 0.187-inch thick rubber applied over the canvas. Blade edge guards shall be preformed to conform to the blade shape and shall be placed over the canvas and rubber covering. The edge guard shall be fabricated of galvanized sheet metal, 18 gauge (0.048-inch), using figure 2 as a guide. Edge guard sections shall be joined by the use of stainless steel screws and double nuts to permit removal of damaged sections of edge guards. A minimum of two, but not more than four, corrosion-resistant steel (stainless steel) straps shall be secured to the metal edge protector. Attachment hardware for the straps shall be stainless steel. Strapping shall be applied on both sides of each blade following the blade surface contour, and positioned to prevent the edge protector from loosening or becoming dislodged during handling, shipment, and storage. The blade edge guard straps shall be protected from contacting the preserved propeller surface by covering the strap with not less than two thicknesses of 8-ounce canvas or cloth reinforced rubber of

0.187-inch thickness. The canvas or rubber shall be secured to the strap to prevent movement during transportation. Blade edge guards shall be free from damage or defects prior to installation. Propellers less than 30 inches in diameter and crated shall have the edges covered with a split heavy rubber hose or equivalent to protect the blade edges. The split rubber hose shall be secured to the propeller by any suitable means.

3.14.1.5 Repairs to preservation. When preservation is damaged, the damaged area shall be inspected in accordance with NAVSEA S9245-AR-TSM-010/PROP and the preservation repaired. Damage to the protective coating specified in 3.14.1.3 shall be repaired by removing an area surrounding the damage by 1 inch in all directions.

The preservative coating shall be re-applied as specified in 3.14.1.3. Damaged edge guards that may result in damage to the propeller shall be replaced. Damaged straps and hub end closures shall be replaced if inadequate protection of the propeller will result. Damaged areas shall be tagged or marked "DAMAGE INVESTIGATED" with the date and investigating activity noted on the tag.

3.14.2 Propeller packing.

3.14.2.1 Controllable-pitch and bolted-on blades. Controllable-pitch and bolted-on blades preserved as specified above shall be packed in hub sets. References to eye bolts and propeller diameters specified herein shall be disregarded. Multiple containers for a single hub set are required when the size and/or weight of the blades is too large to permit handling by forklift. Wood materials utilized for container construction shall be as specified in 3.8.2.2 for multiple trip use. Containers shall be assembled with corrosion resistant (stainless steel) screws. Viewing ports shall be added to two sides of the crate and shall be hinged with corrosion resistant (stainless steel) hinges to permit visual examination of the crate interior. The viewing ports shall be capable of being secured during transportation and storage. Controllable pitch and bolted on blades shall be positioned in crates with the blade serial number and stock number up. Crate tops shall be attached with corrosion resistant (stainless steel) hex head bolts to permit removal and reuse of the container top. The exterior of each container shall be marked as specified in 3.14.4.4. Packing of controllable-pitch and single bolted-on blades is shown on figure 3.

3.14.2.2 Monobloc. Propellers, 40 pounds and greater, shall be individually packed and provided with lifting eye bolts to facilitate propeller handling, including placement and removal from its shipping and storage container. Monobloc propellers shall be marked as specified in 3.14.4.2. Container figures applicable to propellers will require modification to accommodate propeller eye bolts.

3.14.2.2.1 Propellers, 30 inches in diameter and less. Propellers, 30 inches in diameter and less, shall be multiple or individually packed in multiple-trip containers (see 6.2) as follows:

- (a) Multiple pack. - Propellers shall be packed in wood boxes (see figure 4) in accordance with PPP-B-621, class 2, style 2, for type 3 load. Box components shall be joined by corrosion resistant (stainless steel) screws. Wood materials utilized for container construction shall be as specified in 3.8.2.2 for multiple trip use. Sheathing, ends, and cleats shall be not less than 1-inch lumber. A diagonal cleat to the same size as the regular cleats shall be used on each end of the box. One intermediate set of inside cleats or battens of not less than nominal 1- by 4-inch lumber shall be nailed and clinched to the sides, top, and bottom midway between the ends. Hubs of propellers shall be fitted with suitable wood cones with drilled centers to fit a suitable tie bolt on which propellers shall be strung. Tie bolts shall be

securely suspended between the ends of the box by use of nominal 2- by 10-inch members securely cleated to the inside of the box ends. The size of the box shall ensure not less than approximately 1 inch clearance on top, sides, and ends. Boxes greater than 48 inches long shall be provided with an intermediate saddle midway between the ends which firmly supports the tie bolt from all sides. The saddle support shall be securely attached to the sides, top, and bottom of the box. Suitable blocking which will not injure or mar the blades shall be provided to prevent propellers from turning on the tie bolt. Boxes shall be provided with skids in accordance with the applicable box specification. The gross weight of each box shall be not greater than 600 pounds.

- (b) Individual packs.
- (1) Propellers shall be packed in wood boxes in accordance with PPP-B-621, class 2, style 2 (reinforced), type 3 load as shown on figure 5. Wood materials utilized for container construction shall be as specified in 3.8.2.2 for multiple trip use. Box components shall be joined by corrosion-resistant (stainless steel) screws. Blocking shall be cut from nominal 2- by 6-inch or 2- by 8-inch lumber with a minimum 10-inch length. Blocking shall be cut in pairs with the angle of cut in conforming to the blade angles as shown on figure 6. Blocks shall be covered with at least three thicknesses of type 1, grade A, class 2 material in accordance with MIL-B-121 at areas of contact with the blades.
 - (2) When specified (see 6.2), propellers shall be individually packed in corrugated fiberboard boxes in accordance with ASTM D 5118, class weather-resistant, full overlap style as shown on figure 7. Blocking, bracing, and fillers shall be of the same material as the box except liners at blade contact area shall be solid fiberboard. Fillers, as required, shall be used under and over the hub areas and cut to fit snugly within the blocking sleeve. Propeller edges and finished faces of the hub shall be covered with barrier material in accordance with type I, grade A, class 2 of MIL-B-121. Interior blocking, bracing, and fillers as shown on figure 7 shall be used for two- and three-bladed propellers. Boxes shall be closed in accordance with sealing method B or C of ASTM D 1974.

3.14.2.2.2 Propellers, 30 to 60 inches in diameter. Propellers shall be individually packed in wood boxes in accordance with PPP-B-621, class 2, style 2, (reinforced), type 3 load as shown on figures 8 and 9. Wood materials utilized for container construction shall be as specified in 3.8.2.2 for multiple trip use. Box components shall be joined by corrosion-resistant (stainless steel) screws. Joists shall span the box width. Table II specifies joist sizes, as required, for various loads and spans. The joist supports shall be at least 2 inches wider than the depth of the joists, for example 2- by 4-inch joists require a 2- by 6-inch support.

TABLE II. Sizes of double joists require to support propellers in a wood box.

| Weight of propeller (pounds) | Size of joists ^{1/} required for span of: | | | | | |
|------------------------------|--|-------------|-------------|-------------|-------------|-------------|
| | 30 (inches) | 36 (inches) | 42 (inches) | 48 (inches) | 54 (inches) | 60 (inches) |
| Up to 400 | Two 2 by 4 | Two 2 by 4 | Two 2 by 4 | Two 2 by 4 | Two 2 by 4 | Two 2 by 6 |
| 400 to 600 | Two 2 by 4 | Two 2 by 4 | Two 2 by 4 | Two 2 by 6 | Two 2 by 6 | Two 2 by 6 |

^{1/} Joists are used in pairs as shown.

Propellers greater than 600 pounds shall be packed in a container consisting of a skid type base and a container cover as shown on figure 10. The skid base and member sizes shall conform to MIL-C-104. The container cover shall be a modified class 2, style 2 (reinforced), type 3 load box in accordance with PPP-B-621 consisting of ends, sides, and a top. The ends of the cover shall become the sides and shall be fastened to the base skids. The sides shall become the ends and shall be fastened to the base headers. The cover ends (sides) shall be reinforced on the interior with nominal 1- by 4-inch battens and diagonals. A blot spacing member supported by side bracing members of not less than nominal 2- by 10-inch lumber extending the full width of the box shall be screwed to the top and bottom of the box, midway between the ends. The cover shall be attached to the skid type base by hex-head, corrosion-resistant (stainless steel) screws to permit ready removal and installation. The hub of the propeller shall be fitted with a suitable wood cone with drilled centers to fit a suitable 3/4-inch tie bolt on which the propeller shall be strung. The 3/4-inch tie bolt shall be suspended between the 2- by 10-inch bolt spacing members. A hole shall be drilled in the sheathing, top, and bottom to accommodate the bolt head and nut, so that counter-sinking will not be necessary in the bolt spacing member. The size of the box shall ensure not less than approximately 2 inches clearance on top, sides, and ends. Blocking which will not injure or mar the blades shall be provided to prevent the propeller from turning on the tie bolt. Boxes shall be strapped in accordance with PPP-B-621.

3.14.2.2.3 Propellers, 60 to 108 inches in diameter. Propellers, 60 to 108 inches in diameter shall be individually packed in an open-type crate with a skid-type base as shown on figures 10, 11, and 12. Container (cover and base) member sizes, fastening, and assembly shall be in accordance with MIL-C-3774, MIL-C-104, or ASTM D 6039, as applicable, except all components shall be fastened with corrosion-resistant (stainless steel) screws. Wood materials utilized for crate construction shall be as specified in 3.8.2.2 for multiple trip use. The crate size shall allow not less than 4 inches of clearance between the propeller and the interior surfaces of the container top, sides, and ends. The maximum size propeller packed in a crate shall not exceed the common carriers' dimensions for such cargo. When crates exceed rail shipment limitations, propellers shall be shipped uncrated and in accordance with the requirements for propellers greater than 108 inches in diameter (see 3.14.2.2.4). The base of the crate shall be reinforced with at least 6- by 10-inch wood, load-bearing members. Blocking that will not mar or injure the blades, protective coating, or edge guards shall be provided to prevent propeller movement and shifting within the crate during handling, shipment, and storage.

3.14.2.2.4 Propellers greater than 108 inches in diameter. Propellers greater than 108 inches in diameter do not require packing.

3.14.3 Propeller accessories. Accessory parts for propellers do not require preservation. Items shall be individually packaged or wrapped to prevent contact with adjacent parts. Accessories shall be placed in a single wooden reusable box in such a manner as to prevent movement of the accessories during transportation (see 3.7.8). The accessory box shall be in accordance with MIL-B-233, type W, class 1. Materials for the accessory box shall be as specified in 3.8.2.2 for multiple trip use. An index list of accessories shall be as specified in 3.7.7. The use of dunnage as a filler material is prohibited. The box shall be assembled with corrosion resistant (stainless steel) screws. The top cover of the box shall be attached with hex-head corrosion resistant (stainless steel) screws to permit ready removal and installation. The accessory box shall be attached to the propeller blade by banding or strapping to prevent the box from movement during shipment. Accessories should not be placed in a manner to restrict the bore opening or interfere with handling. In some cases it may be desirable to place wood braces between adjacent blades and attach the accessory box to the brace. Cloth impregnated rubber shall be placed between the accessory box and the strippable coating to prevent damage. Accessory box skids may be cut to conform to the blade surface contour. The accessory box shall be painted white prior to marking.

3.14.4 Propeller marking.

3.14.4.1 All propellers. Propellers markings shall be stenciled on the outer layer of preservation. Markings shall be 1/2 inch in height for propellers 30 inches in diameter or less and 1 inch in height for propellers greater than 30 inches in diameter. Markings shall be applied in accordance with MIL-STD-129 / MIL-HDBK-129 except that wood containers shall be stenciled in all capital letters. A contrasting color oil based paint shall be applied to the wood surface prior to stenciling.

3.14.4.2 Monobloc propeller marking. The following markings shall be applied to each monobloc propeller blade; items in quotations shall be marked exactly as indicated:

- (a) Serial number (NAVSEA or customer assigned).
- (b) National Stock Number.
- (c) Level of preservation/packaging and date.
- (d) Ship class.
- (e) Condition code of the propeller.
- (f) Weight and cube.
- (g) "DO NOT REMOVE BLADE EDGE PROTECTORS UNTIL PROPELLER INSTALLATION IS COMPLETE".
- (h) "HANDLE BY EYEBOLTS".
- (i) "IF PRESERVATION OR PROPELLER IS DAMAGED, NOTIFY NAVICP 05824, MECHANICSBURG PA.".

3.14.4.3 Built-up and controllable-pitch propeller blade marking. The following markings shall be applied to each built up or controllable-pitch propeller blade; items in quotations shall be marked exactly as indicated:

- (a) Serial number (NAVSEA or customer assigned).
- (b) National Stock Number.
- (c) Level of preservation/packaging and date.
- (d) Ship class.
- (e) Condition code of the propeller.
- (f) Weight and cube.
- (g) "DO NOT REMOVE BLADE EDGE PROTECTORS UNTIL PROPELLER INSTALLATION IS COMPLETE".
- (h) "IF PRESERVATION OR PROPELLER IS DAMAGED, NOTIFY NAVICP 05824, MECHANICSBURG PA.".

- (i) "HANDLE WITH SPECIAL TOOLING ONLY".

3.14.4.4 Propeller or propeller blade container marking. The following markings shall be applied to each propeller or propeller blade container; items in quotations shall be marked exactly as indicated:

- (a) Serial number (NAVSEA or customer assigned).
- (b) National Stock Number.
- (c) Level of preservation/packaging and date.
- (d) Ship class.
- (e) Condition code of the propeller.
- (f) Weight and cube.
- (g) Crate number (1 of ____).
- (h) "IF CONTAINER IS DAMAGED, NOTIFY NAVICP 05824, MECHANICSBURG PA."
- (i) "REUSABLE CONTAINER".
- (j) "CENTER OF BALANCE".
- (k) "FORK HERE".
- (l) "DO NOT STACK".
- (m) "STOW FLAT ON CONTAINER SKIDS".
- (n) "CAUTION: THIS SIDE UP" (with arrows).

3.14.4.5 Propeller accessory box marking. The following markings shall be applied to each accessory box in accordance with MIL-STD-129 / MIL-HDBK-129 except that wood containers shall be stenciled in all capital letters 1 inch in height ; items in quotations shall be marked exactly as indicated:

- (a) Serial number of propeller (NAVSEA or customer assigned).
- (b) National Stock Number of propeller.
- (c) Level of preservation/packaging and date.
- (d) Ship class.
- (e) "IF CONTAINER IS DAMAGED, NOTIFY NAVICP 05824, MECHANICSBURG PA."
- (f) Weight (of accessory box only).
- (g) "REUSABLE CONTAINER".
- (h) "CENTER OF BALANCE".

3.14.5 Propeller certification form. The certification form shall be enclosed in a minimum 0.004-inch thick transparent, waterproof, greaseproof resealable bag (zip-lock or equivalent) to permit removal and replacement of the certification form. The bag shall be prominently marked "Certification Form". The bag shall be attached with tape in accordance with MIL-T-22085, type II, on a monobloc propeller hub or controllable pitch propeller blade adjacent to the stamped propeller identification data. On monobloc propellers, the resealable end of the bag shall be placed at the bottom to exclude water. The resealable end of the bag may be folded to provide an additional seal. The propeller certification form shall remain visible, readily available, and shall remain with the propeller until propeller use. When propellers are boxed or crated, an additional copy of the certification form shall be firmly affixed to the outside of the shipping container in a protected location, preferably between the cleats on the end of the container adjacent to the identification markings. For individually crated blades of a set, the certification form shall be placed on the first blade of each set. A copy of the certification form shall be placed in the monobloc accessory box for information. The certification form shall only be removed by personnel performing preservation inspections at the storage and installation activities.

3.14.6 Transportation requirements.

3.14.6.1 Rail and barge shipment of monobloc propellers. Propellers shall be blocked with timber cribbing and topped by a rounded timber shaft which shall support the propeller as shown on figure 13. The wood members

shall be of 10- by 10-inch or 12- by 12-inch timber. The support member shall be covered to prevent propeller hub damage. Cleats shall be used to align and fasten the crib members together. Steel rods, threaded at each end, shall be used to fasten the timbers to the car floor. Steel tie rods, not less than 1-inch diameter, shall be fastened to the timber shaft and to the car floor to provide longitudinal bracing. Blocking and bracing shall be applied between the crib walls to prevent side movement. To prevent propeller rotation, either blocking between the propeller blades and crib walls or holddown rods shall be installed. The propeller blades shall not be used to support the propeller weight or to block, brace or prevent shifting of the propeller and shall not extend through an orifice or any opening in the car floor. Loading on open cars shall meet the requirements of the Association of American Railroads Rules governing car loading.

3.14.6.2 Truck shipments of monobloc propellers. The carrier vehicle shall transport the propeller, forward face down, in a tilted position either on a separate shipping frame (see figure 1) or securely mounted on the carrier. The carrier shall contain a propeller centering and securing system consisting of, but not limited to:

- (a) A steel, threaded, centering shaft secured to the carrier.
- (b) A wood plug, padded clamps, or braces at the base of the propeller hub to center the propeller on the centering shaft.
- (c) A metal centering plate of not less than 1/2-inch thickness, predrilled, to accommodate the propeller centering shaft and lifting eyebolts (see 3.14.2.2).

Metal plates shall be provided by the activity shipping the propeller. A non-metallic gasket-type barrier shall be placed between the metal plate and the propeller hub. Chains or other metallic holddown devices that are added, when required for shipment and safety purposes, shall be covered with heavy duty chafing gear such as rubber or fire hose. Hold down devices shall be arranged and secured to the carrier and propeller in a manner so that no contact with the propeller blade and blade edges shall ensue during handling and shipment.

3.14.6.3 Shipments of built-up or controllable-pitch propellers. Crated built-up or controllable-pitch propellers shall be transported in accordance with federal and state trucking regulations. Crates shall be protected from exposure to the weather by a tarp or other suitable covering.

3.14.7 Storage of propellers. Each monobloc propeller or controllable pitch propeller crate shall be placed on wood skids of sufficient size to support the propeller or crate above the ground level. Alternatively, each propeller may be supported on a skid-type base. Storage shall be on a concrete slab with a weight bearing capacity greater than the weight of the propeller. Propellers shall be stored in an unheated warehouse when possible. When warehouse space is not available, propellers shall be stored in open covered storage. Open covered storage is defined as storage inside an open-type cover consisting of sides, ends, and top. The cover may be of the nailed or demountable type, and of wood or metal construction. Access areas such as a door shall be constructed to permit personnel entry into the covered storage for inspection of the propeller. A clearance of not less than 12 inches shall be allowed between the propeller and closest member of the container cover. When in open covered storage, a flexible, waterproof cover shall be placed over the container. Crated propeller blades shall not be stacked and shall be covered with a waterproof cover. Propellers shall not be stored where surface temperatures of the propeller will exceed 150 degrees Fahrenheit (°F). Monobloc propellers shall be stored on the forward face. The following specifications may be used for guidance in material selection, fabrication, and assembly of the skid-type base and cover:

Base - MIL-C-104.

Cover - MIL-C-3774, MIL-C-9897, or ASTM D 6039.

3.14.8 Propeller devices. Devices shall be cleaned in accordance with NAVSEA S9245-AR-TSM-010/PROP. Devices shall be individually preserved as specified in 3.14.1, 3.14.1.3, and 3.14.1.4. In addition, the device shall be unit protected in opaque packaging materials in accordance with MIL-S-196. Devices shall be secured to a skid-type base. Device boxes shall be in accordance with PPP-B-601 (overseas type) or PPP-B-621, class 2. Wood materials utilized for container construction shall be as specified in 3.8.2.2 for multiple trip use. The skid-type base shall be of a design and construction format similar to the skid bases in accordance with MIL-C-104. The container shall be assembled with corrosion resistant screws (stainless steel). Anchoring of the device shall be in accordance with the appendix to MIL-C-104. A neutral barrier material shall be applied to all wood surfaces that come in direct contact with the device. For devices mounted on skid-type bases, further protection shall be provided by a closed-type, bolted, wood constructed cover (sides, ends, and top) similar to MIL-C-3774, type II, except that MIL-C-104 shall be used for guidance in selection of sizes of members and hardware for the cover assembly and fastening to the skid-type base. Device attachment bolts and other attached components of cap assemblies shall be packed within the device container. Device certification documents shall be as specified in 3.14.5. Devices shall be stored as specified in 3.14.7. Device container markings shall be 1 inch high and applied in accordance with MIL-STD-129 / MIL-HDBK-129 except that wood containers shall be stenciled in all capital letters. A contrasting color oil based paint shall be applied to the wood surface prior to stenciling. Device container markings shall be as follows; items in quotations shall be marked exactly as indicated:

- (a) Serial number (NAVSEA or customer assigned).
- (b) National Stock Number.
- (c) Level of preservation/packaging and date.
- (d) Ship class.
- (e) Weight and cube.
- (f) Condition code of the device.
- (g) "IF CONTAINER IS DAMAGED, NOTIFY NAVICP 05824, MECHANICSBURG PA."
- (h) "REUSABLE CONTAINER".
- (i) "CENTER OF BALANCE".
- (j) "FORK HERE".
- (k) "DO NOT STACK".
- (l) "STOW FLAT ON CONTAINER SKIDS".
- (m) "CAUTION: THIS SIDE UP" (with arrows).
- (n) "SLING HERE".
- (o) "CONTAINER TO BE OPENED BY INSTALLING ACTIVITY ONLY".

3.14.9 Propeller fairwater caps. Propeller fairwater caps, also known as dunce caps, shall be cleaned in accordance with NAVSEA S9245-AR-TSM-010/PROP. Fairwater caps shall be individually preserved as specified in 3.14.1 and 3.14.1.3. Fairwater caps greater than 200 pounds shall be cradled and secured to a skid-type base. Other cap boxes shall be in accordance with PPP-B-601 (overseas type) or PPP-B-621, class 2. Wood materials utilized for container construction shall be as specified in 3.8.2.2 for multiple trip use. The skid-type base shall be of a design and construction format similar to the skid bases in accordance with MIL-C-104. Anchoring of the cap shall be in accordance with the appendix to MIL-C-104. A neutral barrier material shall be applied to all wood surfaces that come in direct contact with the cap. For caps mounted on skid-type bases, further protection shall be provided by an open-type, bolted, wood constructed cover (sides, ends, and top) similar to MIL-C-3774, type II, except that MIL-C-104 shall be used for guidance in selection of sizes of members and hardware for the cover assembly and

fastening to the skid-type base. Cap attachment bolts and other attached components of cap assemblies shall be packed within the cap container. Caps shall be stored as specified in 3.14.7. Fairwater cap container markings shall be 1 inch high and applied in accordance with MIL-STD-129 / MIL-HDBK-129 except that wood containers shall be stenciled in all capital letters. A contrasting color oil based paint shall be applied to the wood surface prior to stenciling. Fairwater cap container markings shall be as follows; items in quotations shall be marked exactly as indicated:

- (a) Serial number (NAVSEA or customer assigned).
- (b) National Stock Number.
- (c) Level of preservation/packaging and date.
- (d) Ship class.
- (e) Weight and cube.
- (f) Condition code of the cap.
- (g) "IF CONTAINER IS DAMAGED, NOTIFY NAVICP 05824, MECHANICSBURG PA."
- (h) "REUSABLE CONTAINER".
- (i) "CENTER OF BALANCE".
- (j) "FORK HERE".
- (k) "DO NOT STACK".
- (l) "STOW FLAT ON CONTAINER SKIDS".
- (m) "CAUTION: THIS SIDE UP" (with arrows).
- (n) "SLING HERE".

3.15 Shafting.

3.15.1 General. The requirements for ready for issue (RFI) and not ready for issue (NRFI) shafts are identical except as specified herein. Preservation for shafting shall be level A in accordance with this specification unless otherwise specified. Alternate methods for shafting preservation and packaging may be utilized with the prior approval of the cognizant technical authority through the contracting activity. Shafting accessories such as propeller nuts and keys shall not be installed on the shaft and shall be preserved as specified in 3.15.2. Wood materials utilized for container construction and packaging shall be as specified in 3.8.2.2 for multiple trip use.

3.15.2 Shafting preservation. Shafting surfaces shall be cleaned prior to preservation. Corrosion shall be removed from metal surfaces by wire brushing. The shaft shall then be cleaned with a petroleum based solvent such as P-D-680 or ASTM D 4376. The solvent may be sprayed, brushed, or wiped to ensure the shaft is clean of all foreign matter. As a final cleaning step, the shaft surfaces shall be wiped with lint-free cloths with solvent in accordance with P-D-680 or ASTM D 4376. For RFI shafts, shaft sleeves made from bronze, Inconel, or copper-nickel shall also be wiped. Used shaft sleeves on NRFI shafts do not require corrosion removal or cleaning. All shafting surfaces shall be dried by wiping with lint-free cloths and allowed to air dry prior to preservation. Preservation shall take place immediately after cleaning and drying. All metal unpainted shaft surfaces, including shaft sleeves, shall be preserved with two coats of preservative in accordance with MIL-PRF-16173, grade 1. Application may be made by dipping, flow coating, slushing, brushing, spraying, or other suitable process. During and after preservative application, the product shall be handled in such a manner as to produce a uniform protective film. The protective film shall remain untouched for a period of time to allow the film to set before application of the second coat or wrapping and packing are undertaken. Used sleeves on NRFI shafts do not require preservation.

3.15.3 Shaft bore preservation. Each end of hollow shafts shall be sealed to prevent entry of water and other foreign material. Hollow shaft bores previously sealed with watertight steel or other suitable metal plugs as

required on the applicable shafting drawing or technical repair standard do not require further preservation of the shaft bore. Finished and unfinished shaft bores not sealed by metal plugs shall be sealed with wood plugs or disks. The wood plugs shall be attached to the shaft and sealed with a commercial grade butyl rubber adhesive to provide a watertight seal. The exposed ends of prairie air piping installed in a shaft shall be sealed with plastic caps or plugs prior to the sealing of the shaft bore.

3.15.4 Shaft packaging. After preservation, external shaft surfaces including fiberglass areas shall be provided a preliminary wrap of greaseproof barrier material in accordance with MIL-B-121, type I, grade A, class 2 followed by an overwrap with type I, grade C, class 1 or 2 at the packaging activities option. After covering with the greaseproof material, all external shaft surfaces shall be securely wrapped with a minimum of three layers of not less than 8-ounces canvas or equivalent. Canvas seams shall be taped with heavy duty tape such as duct tape. The above protected surfaces shall then be provided physical protection as specified in 3.15.4.1 or 3.15.4.2 at the option of the packaging activity. The methods specified in 3.15.4.1 and 3.15.4.2 shall not be combined on the same shaft. NRFI shafts with used sleeves do not require packaging of the shaft sleeve areas.

3.15.4.1 Galvanized covering. Shafting shall be covered by application of approximately 0.0179 ± 0.005 -inch thick (26 gauge) galvanized steel wrap secured by means of flat, nailless type corrosion resistant (stainless steel) bands. The horizontal seams of the steel wrap shall be positioned on the bottom to prevent the entry of water or other foreign matter under the steel wrap. There shall be a minimum of two stainless steel bands per sheet of galvanized steel wrap placed 6 inches in from each end of the wrap. Additional sections of galvanized steel wrap shall overlap the adjoining section by a minimum of 2 inches. All seams shall be covered with a double layer of tape in accordance with MIL-T-22085, type II or type IV.

3.15.4.2 Wood lagging. Shafting shall be covered by application of nominal 1- by 2-inch wood strip lagging (as shown on figure 14) running the entire length of the protected surface. Wood materials utilized for wood lagging shall be as specified in 3.8.2.2 for multiple trip use. Lagging strips shall be spaced a maximum of 1 inch apart and shall be secured in place by means of flat, nailless type corrosion resistant (stainless steel) bands. The bands shall extend around the circumference of the shaft and shall be clamped with stainless steel cleats. There shall be a minimum of two straps for each section of wood lagging. Identified sling points of the shaft shall have an additional layer of wood lagging, 2 feet long, centered on the sling point.

3.15.5 Shaft flanges. Shaft flange faces shall be protected by means of a 2-inch nominal thick wood disk of greater diameter than the flange, which shall be secured to the flange faces. Wood materials utilized for flange faces shall be as specified in 3.8.2.2 for multiple trip use. A layer of barrier material in accordance with MIL-B-121, type I, grade A, class 2, shall be placed between the wood disks and metal surfaces. Flange peripheries shall be protected by the use of wood lagging as specified in 3.15.4.2.

3.15.6 Shaft packing.

3.15.6.1 Three inches in diameter and less. Shafting, 3 inches in diameter and less, shall be packed in wood boxes in accordance with PPP-B-621, style 1, modified as shown on figure 15 herein. Wood materials utilized for container construction shall be as specified in 3.8.2.2 for multiple trip use. Table III specifies sizes of members for boxes depending on shaft diameter, shaft length, and shaft weight. Container sides, ends, top, and bottom shall be one piece or Linderman jointed and without end butt joints for lengths up

to 16 feet. For lengths greater than 16 feet, end butt joints are acceptable. Butt joints shall be alternated and located only in the end one-third area of the length.

TABLE III. Size of members for wood containers, shafting
3 inches in diameter and less.^{1/,2/}

| Shafting | | | Member sizes | | | Maximum Spacing of Cradles (inches) |
|---------------------------|-----------------------|-------------------------|----------------|---------------|----------------------|-------------------------------------|
| Maximum diameter (inches) | Maximum length (feet) | Maximum weight (pounds) | Sides (inches) | Ends (inches) | Cross skids (inches) | |
| 1-1/2 | 12 | 100 | 1 by 4 | Two 2 by 4 | 2 by 3 | 16 |
| 1-1/2 | 14 | 200 | 2 by 4 | Two 2 by 4 | 2 by 3 | 16 |
| 2 | 20 | 200 | 2 by 6 | Two 2 by 6 | 2 by 3 | 18 |
| 3 | 25 | 300 | 2 by 8 | Three 2 by 8 | 2 by 4 | 20 |
| 3 | 16 | 400 | 2 by 6 | Three 2 by 6 | 2 by 4 | 20 |
| 3 | 20 | 400 | 2 by 8 | Three 2 by 8 | 2 by 4 | 20 |

^{1/} For tops and bottoms, nominal 1-inch lumber shall be used. When the width of top and bottom is greater than 7-1/2 inches, 1- by 2-inch battens spaced approximately 3 feet apart shall be used; or 3/4-inch plywood, end spliced when required, shall be used in place of lumber.

^{2/} Cradles shall be of 2-inch material with 1/4-inch plywood backing when shafts exceed 2-inch diameter.

3.15.6.2 Finished shafting and rough machined shaft forgings, greater than 3 inches in diameter. One shaft complete with accessory parts, when applicable, shall be cradled on a skid-type base (see figures 14 and 16 and MIL-C-104 for construction guidance). Unless otherwise specified (see 6.2), table IV shall apply for skid base size members. Wood materials utilized for container construction shall be as specified in 3.8.2.2 for multiple trip use.

Shafts and accessory parts where applicable shall be so cradled, mounted, and secured on the skid base to prevent shaft deflection, shifting, and damage that may result from storage, handling, and shipment. Skids less than 16 feet in length shall not be spliced. Laminating and splicing of skids shall be in accordance with MIL-C-104. End headers shall be placed flush with skid ends and bolted in place. Flanges shall be enclosed within a box as shown on figure 14. The flange box shall be of sufficient size to enclose the packaging specified in 3.15.4.1 or 3.15.4.2. To protect the bottom of the flange, a nominal 2-inch thick wood member the width of the flange box shall be secured to the skids directly beneath the flange box.

TABLE IV. Sizes of members in skid assemblies for shipment of propulsion shafting greater than 3 inches in diameter.

| Item | Size of members for shafts with diameters of: | | | |
|--|---|--|---|---|
| | Greater than 3 inches but less than 8 inches (inches) | 8 inches to less than 16 inches (inches) | 16 to 24 inches (inches) | Greater than 24 Inches (inches) |
| Skids | 4 by 4 or two 2 by 3's (flat) | 4 by 6 (flat) or two 2 by 6's (flat) | 4 by 8 (flat) | 6 by 8 |
| End headers | 4 by 4 | 4 by 6 (flat) | 4 by 8 (flat) | 4 by 8 (flat) |
| Cross skids ^{3/} | 3 by 4 (flat) | 4 by 4 | 4 by 4 | 4 by 4 |
| Cradles ^{1/} (cutout) | Two 4 by 6's to 4 by 8 | Two 4 by 8's to 4 by 12 | Two 4 by 12's to 4 by 16 laminate with 3/4-inch plywood | Two 4 by 16's and larger laminate with 3/4-inch plywood |
| Cradle ^{2/} spacing (maximum) | 20 | 36 | 2-1/2 times diameter | 2 times diameter |
| Lagging | 1 by 2 | 2 by 2 | 2 by 2 | 2 by 2 |

^{1/} Cradles shall be fabricated in two equal parts, the bottom and top halves cut to fit the shaft snugly with allowance for preservation, wrapping, lagging, or other protection. Laminated cradles shall be used for shafts exceeding 16 inches in diameter.

^{2/} The number and location of cradles shall be adjusted so that they are located at the quarter points for sling lifting. The maximum spacing between cradles is limited to 4 feet.

^{3/} Cross skids shall be located at each cradle and shall be bolted to the skids with the same bolts used to fasten the cradle.

3.15.7 Shaft accessories. Shaft accessories such as keys and propeller nuts shall be cleaned and preserved as specified for shafting in 3.15.2. Shaft accessories shall be individually wrapped with a barrier material in accordance with MIL-B-121, type 1, grade A, class 2. Accessories shall be packed in a single wood or metal box braced to prevent movement during transportation. Wood materials utilized for container construction shall be as specified in 3.8.2.2 for multiple trip use. The accessory box shall be permanently attached to the shaft skid base. The use of dunnage as a filler material is prohibited. The box shall be assembled with corrosion resistant (stainless steel) screws. The top cover of the box shall be attached with hex head corrosion resistant (stainless steel) screws to permit ready removal and installation of accessories.

3.15.8 Technical reports. When the item specification requires the technical report be included with the shipment, technical reports shall be enclosed in a minimum 0.004-inch thick transparent, waterproof, greaseproof resealable bag (zip-lock or equivalent) to permit removal and replacement of the technical report. The bag shall be prominently marked "Technical Report". The technical report shall be placed in a wood box of suitable size for the report. The wood box shall be permanently affixed to the shaft skid type base. Wood materials utilized for the technical report box shall be as specified in 3.8.2.2 for multiple trip use. The top of the technical report box shall be attached with corrosion resistant hex-head screws to permit removal and replacement of the report.

3.15.9 Shaft marking. Shaft markings shall be stenciled on the outer layer of packing or container. Marking shall be 1 inch in height. Markings shall be applied in accordance with MIL-STD-129 / MIL-HDBK-129 except that wood containers shall be stenciled in all capital letters. A contrasting color oil based paint shall be applied to the wood surface prior to

stenciling. The following markings shall be applied to each shaft package or container; items in quotations shall be marked exactly as indicated:

- (a) Serial number (NAVSEA or customer assigned).
- (b) National Stock Number.
- (c) Level of preservation/packaging and date.
- (d) Ship class.
- (e) Weight & cube.
- (f) Condition code of the shaft.
- (g) "REUSABLE CONTAINER".
- (h) "SLING HERE".
- (i) "CENTER OF BALANCE".
- (j) "DO NOT STACK".
- (k) "STOW FLAT ON CONTAINER SKIDS".
- (l) "FORK HERE" (as applicable for small shafting).
- (m) "CONTAINER/PACKAGING TO BE OPENED ONLY BY THE INSTALLATION ACTIVITY".
- (n) "CAUTION: STORE ON LEVEL CONCRETE OR STEEL SURFACE ONLY. TRANSPORT BY RAIL OR VEHICLE IN A MANNER THAT THE SKID SYSTEM IS FULLY SUPPORTED. OVERHANG IS NOT PERMITTED. FOR OCEAN TRANSPORT, THE CONTAINER MUST BE STOWED IN/ON FLAT LEVEL HOLD OR DECK. LIFT CONTAINER AT SLING POINTS ONLY. DO NOT LIFT FROM ONE END."
- (o) "TECHNICAL REPORT ENCLOSED" (on technical report box).

3.15.9.1 Surface craft shafting. In addition to the markings specified in 3.15.9, the following additional markings shall be applied to surface craft shafting if the shaft is a NAVICP managed shaft:

"IF PACKAGING/PRESERVATION IS DAMAGED, NOTIFY NAVICP 05824, MECHANICSBURG PA."

3.15.9.2 Submarine shafting. In addition to the markings specified in 3.15.9, the following additional markings shall be applied to submarine shafting if the shaft is a NAVICP managed shaft:

- (a) "IF PACKAGING/PRESERVATION IS DAMAGED, NOTIFY NAVICP 84211H, MECHANICSBURG PA."
- (b) ITEM DESCRIPTION.
- (c) QUANTITY AND UNIT OF ISSUE.
- (d) CONTRACT NUMBER.
- (e) MATERIAL IDENTIFICATION AND CONTROL (MIC) NUMBER.
- (f) "SUBSAFE", Marked in red and placed on all sides of the container.

3.15.10. Transportation requirements. Shafts shall be handled by identified sling points only. The skid base shall be fully supported along its length during transportation. Overhang of the skid base is not permitted during transportation. Shafts shall be transported in the horizontal position. Strap or cable tie downs shall be padded and located at the sling points when placed across the shaft, and at any point on the skid base. Care shall be taken not to remove or damage the shaft packaging or skid base. Shafts shall be covered with a heavy duty tarp during transportation. When transporting by truck, flat bed trailers shall be utilized to provide full length support for the shaft skid base. Step bed trailers and cribbing under the skid base is not permitted. When transporting shafts by rail, shafts shall be placed in a flat bottom gondola car whenever possible. When a gondola car is not used due to shaft length, a flat car may be utilized. The shaft and skid base shall be braced and blocked to prevent movement in any direction. Shafts transported over water via barge or ship shall be transported in a similar manner to truck and rail shipments.

3.15.11 Shaft storage. Steel shafting shall be stored in an east-west direction to avoid build up of residual magnetism. Temporary storage of semi-finished or finished shafting prior to preservation or packaging shall be on a flat concrete or steel surface with cradles spaced at a maximum of every 4 feet for shafts greater than 15 feet in length with adequate weight bearing capacity. Storage of preserved and packaged shafting shall be on a flat concrete or steel slab with a weight bearing capacity greater than the weight of the shaft with packaging. Shafting shall be stored in a warehouse when possible. When warehouse space is not available, shafting shall be stored in open covered storage. Open covered storage is defined as storage inside an open-type cover consisting of sides, ends, and top. The cover may be of the nailed or demountable type, and of wood or metal construction. The enclosure shall provide for impact and weather protection. Access areas such as a door shall be constructed to permit personnel entry into the covered storage for inspection of the shaft. A clearance of not less than 12 inches shall be allowed between the shaft and closest member of the container cover. When in open covered storage, a flexible, waterproof cover shall be placed over the container. Packaged shafts shall not be stacked. The following specifications shall be used for guidance in material selection, fabrication, and assembly of the cover:

Cover - MIL-C-3774, MIL-C-9897, or ASTM D 6039.

3.16 Built-up and controllable-pitch propeller hubs. Preservation for built-up and controllable-pitch propeller hubs shall be Level A in accordance with this specification unless otherwise specified. Alternate methods for controllable-pitch propeller hub preservation may be utilized with the prior approval of the contracting activity.

3.16.1 Preservation of internal surfaces. Each hub shall be filled with the system's normal operating hydraulic fluid, if applicable. An expansion tank with a sight glass to determine the expansion tank fluid level shall be provided to protect the hub against temperature changes and to ensure that the fluid completely fills the hub at all times. Hub openings shall be sealed to prevent leakage during handling, shipment, and storage. Moving parts shall be secured or cushioned in a manner to prevent damage during handling, shipment, and storage. Each hub shall be tagged stating that the hub is filled with the normal operating lubricant, its identification (for example, specification type), including precautionary information necessary for hub handling, shipment, and storage.

3.16.2 Preservation of external surfaces. Built-up and controllable-pitch propeller hubs shall be cleaned in accordance with NAVSEA S9245-AR-TSM-010/PROP, utilizing the same cleaning process for propellers. External surfaces, including hub opening blanks, shall be covered with a transparent preservative in accordance with MIL-PRF-16173, grade 4.

3.16.3 Built-up and controllable-pitch hub packing. Built-up and controllable-pitch propeller hubs shall be packaged as shown on figure 17. Each hub greater than 200 pounds shall be cradled and secured to a skid-type base. Other hub boxes shall be in accordance with PPP-B-601 (overseas type) or PPP-B-621, class 2. The skid-type base shall be of a design and construction format similar to the skid bases specified in MIL-C-104. Wood materials utilized for container construction shall be as specified in 3.8.2.2 for multiple trip use. Anchoring of the hub shall be in accordance with the appendix to MIL-C-104. A neutral barrier material shall be applied to all wood surfaces that come in direct contact with the hub or cap. For hubs mounted on skid-type bases, further protection shall be provided by an open-type, bolted, wood cover (sides, ends, and top) constructed similar to MIL-C-3774, type II, except that MIL-C-104 shall be used for guidance in selection of sizes of members and hardware for the cover assembly and fastening to the skid-type

base. Provisions shall be made in the container for viewing the fluid level sight glass and to access the hydraulic fluid reservoir for the addition of fluid, if required, without opening the container.

3.16.4 Accessory parts for built-up and controllable-pitch propeller hubs. Accessory parts for built-up and controllable-pitch propeller hubs shall be cleaned prior to preservation as specified in 3.7.1. Metal accessories shall be preserved with a transparent preservative in accordance with MIL-PRF-16173, grade 4. Accessories shall be packed within the hub container and secured to prevent movement during handling and transportation.

3.16.5 Built-up and controllable-pitch propeller hub marking. Built-up and controllable-pitch propeller hub container markings shall be 1 inch in height and applied in accordance with MIL-STD-129 / MIL-HDBK-129 except that wood containers shall be stenciled in all capital letters. A contrasting color oil based paint shall be applied to the wood surface prior to stenciling. Container markings shall be as follows; items within parenthesis shall be marked exactly as indicated:

- (a) Serial number (NAVSEA or customer assigned).
- (b) National Stock Number.
- (c) Level of preservation/packaging and date.
- (d) Ship class.
- (e) Weight and cube.
- (f) Condition code of the hub.
- (g) "IF CONTAINER IS DAMAGED, NOTIFY NAVICP 05824, MECHANICSBURG PA."
- (h) "REUSABLE CONTAINER".
- (i) "CENTER OF BALANCE".
- (j) "FORK HERE".
- (k) "DO NOT STACK".
- (l) "STOW FLAT ON CONTAINER SKIDS".
- (m) "CAUTION: THIS SIDE UP" (with arrows).
- (n) "WARNING, INSPECT HYDRAULIC FLUID LEVEL EVERY THREE MONTHS".
- (o) "WARNING, FILL ONLY WITH _____ HYDRAULIC FLUID" (fill in blank, as applicable).
- (p) "FILL HERE", (with arrow indicating hydraulic reservoir filler cap).

3.17 Propeller blade gauges. Propeller blade gauges shall not be coated with a preservative and shall be packed vertically in a laminated (partitioned) container (see figure 18). Unless otherwise specified (see 6.2), containers for blade gauges shall be in accordance with MIL-B-233, type W, class 1. Wood materials utilized for container construction shall be as specified in 3.8.2.2 for multiple trip use. During storage, gauges shall be kept separated from adjacent gauges. Previously manufactured propeller gauge boxes that do not have provision for vertical storage may continue to be utilized. Gauges stored in these containers shall be kept separated and packaged by placing a single sheet of greaseproof material in accordance with MIL-B-121, type I, grade A, class 2 between individual gauges. A copy of the gauge certification form and visual inspection report shall be enclosed in a not less than 0.004-inch thick transparent, waterproof, greaseproof resealable bag (zip-lock or equivalent) to permit removal and replacement of the certification and visual inspection form. The bag shall be prominently marked "Certification Form" and placed inside of the container. Gauges shall be stored in an unheated warehouse. Gauge containers shall be marked in 1-inch letters in accordance with MIL-STD-129 / MIL-HDBK-129 except that wood containers shall be stenciled in all capital letters. A contrasting color oil based paint shall be applied to the wood surface prior to stenciling. Gauge container markings shall be as follows; items in quotations shall be marked exactly as indicated:

- (a) Serial number (NAVSEA or customer assigned).
- (b) National Stock Number.
- (c) Ship class.
- (d) Weight and cube.
- (e) Condition code of the blade gauges.
- (f) "IF CONTAINER IS DAMAGED, NOTIFY NAVICP 05824, MECHANICSBURG PA."
- (g) "REUSABLE CONTAINER".
- (h) "CENTER OF BALANCE".
- (i) "FORK HERE".
- (j) "DO NOT STACK".
- (k) "STOW FLAT ON CONTAINER SKIDS".
- (l) "CAUTION: THIS SIDE UP" (with arrows).
- (m) "SLING HERE".

3.18 Taper plug and ring gauges. Taper plug and ring gauges shall be thoroughly cleaned with a petroleum based solvent in accordance with P-D-680 or ASTM D 4376. Gauges shall be completely covered with a preservative in accordance with MIL-PRF-16173, grade 4. Gauges shall be placed upright in a box with the centerline of the gauge vertical and the box attached to a skid-type base. The boxes shall be in accordance with PPP-B-601 (overseas type) or PPP-B-621, class 2. The skid-type base shall be of a design and construction format similar to the skid bases specified in MIL-C-104 except that the skid base will be square and dimensions of the base shall exceed the height of the container by 6 inches. Wood materials utilized for container and skid construction shall be as specified in 3.8.2.2 for multiple trip use. Gauge containers shall be assembled with corrosion resistant (stainless steel) screws. The container box top shall be attached with hex head corrosion resistant (stainless steel) screws. The gauge shall be blocked and braced with reusable, removable partitions to prevent gauge movement during handling and transportation. A neutral barrier material in accordance with MIL-B-121, type 1, grade A, class 2, shall be applied to all wood surfaces that come in direct contact with the gauge. A copy of the gauge certification form and visual inspection report shall be enclosed in a minimum 0.004-inch thick transparent, waterproof, greaseproof resealable bag (zip-lock or equivalent) to permit removal and replacement of the certification and visual inspection form. The bag shall be prominently marked "Certification Form" and placed inside the gauge container. Gauges shall be stored upright in a warehouse. Gauge containers shall be marked in 1-inch letters in accordance with MIL-STD-129 / MIL-HDBK-129 except that wood containers shall be stenciled in all capital letters. A contrasting color oil based paint shall be applied to the wood surface prior to stenciling. Gauge container markings shall be as follows; items in quotations shall be marked exactly as indicated:

- (a) Serial number (NAVSEA or customer assigned).
- (b) National Stock Number.
- (c) Type of gauge (propeller taper plug, shaft taper ring, etc.).
- (d) Ship class.
- (e) Weight and cube.
- (f) "IF CONTAINER IS DAMAGED, NOTIFY NAVICP 05824, MECHANICSBURG PA."
- (g) "REUSABLE CONTAINER".
- (h) "CENTER OF BALANCE".
- (i) "FORK HERE".
- (j) "DO NOT STACK".
- (k) "STOW FLAT ON CONTAINER SKIDS".
- (l) "CAUTION: THIS SIDE UP" (with arrows).
- (m) "SLING HERE".

4.1 Classification of inspections. The inspection requirements specified herein are classified as follows:

- (a) First article inspection(see 4.2).
- (b) Conformance inspection (see 4.3).

4.2 First article.

4.2.1 First article inspection. The contractor shall inspect one complete package, packed for shipment, to ascertain the cleaning, drying, preservation, packaging, packing, and marking of the equipment or item conform to this specification. The first article sample will not be required when such a pack has previously been inspected and accepted for the same method for an identical or similar item by the same contractor and satisfactory evidence can be furnished to the Government that the equipment or items have been prepared identically with the previously approved pack. First article inspection shall be repeated when changes in preservation, packaging, and packing materials, or processes or designs are made.

4.2.2 First article testing. When specified (see 6.2), the sample first article pack of the equipment or item shall be subjected to the examination and tests in accordance with MIL-STD-2073-1C and the tests as specified herein. A first article test will not be required when one of the following applies:

- (a) Commercial packaging is specified.
- (b) Commercial packing is specified.
- (c) Detailed packing instructions are furnished by the contracting activity.

4.2.2.1 Rough-handling tests. When specified (see 6.2), rough-handling tests shall be conducted. Tests shall be as specified in MIL-STD-2073-1C. For packs greater than 200 pounds (or 100 pounds where equipment is secured to the base of the container) the railroad car test method as specified in 4.2.2.1.1 may be used in place of the pendulum-impact test or incline-impact test in accordance with MIL-STD-2073-1C at the option of the packaging activity.

4.2.2.1.1 Railroad car test method. The pack shall be securely blocked to prevent movement on the car. Anti-skip plates shall not be used for this test. The car shall be impacted at approximately 10 miles per hour.

4.3 Conformance inspection.

4.3.1 Sampling for quality conformance inspection. Sample items, packages, and packs shall be selected and inspected to determine conformance to the requirements of section 3 herein and with MIL-STD-2073-1C.

4.4 Examination.

4.4.1 Preservation. Examination of the preservation and marking requirements not covered by referenced specifications shall be performed on the basis of the sampling procedures and inspection levels being used to determine examination requirements in accordance with MIL-STD-2073-1C.

4.4.1.1 Packing and marking. Examination of packing and marking requirements not covered by MIL-STD-2073-1C or any specification referenced herein shall be performed on sample packs selected in accordance with ANSI Z1.4 at inspection level I. Any pack having one or more defects shall be cause for rejection (see 6.7).

5. PACKAGING

This section is not applicable to this specification.

6. NOTES

(This section contains information of a general or explanatory nature that may be helpful, but is not mandatory.)

6.1 Intended use. The cleaning, drying, preservation, packing, and marking requirements specified herein are intended to ensure proper and safe transportation and storage of equipments and associated repair parts and tools, and for use in preparing packaging requirements in contracts or orders.

6.2 Acquisition requirements. Acquisition documents must specify the following:

- (a) Title, number, and date of the specification.
- (b) Issue of DoDISS to be cited in the solicitation, and if required, the specific issue of individual documents referenced (see 2.2.1 and 2.3).
- (c) When first article inspection is required (see 3.1).
- (d) Level of preservation and packing required (see 3.5.1, 3.7 and 3.8).
- (e) When accessories are not included in equipment container(see 3.7.2.7).
- (f) Quantity of repair parts in each pack (see 3.7.4).
- (g) Preservation requirements of repair parts not covered (see 3.7.4.1).
- (h) Box closure if other than as specified (see 3.7.5).
- (i) Type of repair parts boxes, if required (see 3.7.6).
- (j) Shipping container required if other than packaging activity's option (see 3.8.2).
- (k) Plywood selection if other than as specified (see 3.8.2.2.1).
- (l) Wood preservative if other than as specified (see 3.8.2.2.1).
- (m) Crate type and style if other than packaging activity's option (see 3.8.2.3).
- (n) Gross weight exception for repair parts boxes (see 3.8.2.6).
- (o) Special marking, if required (see 3.9).
- (p) Preservation of boat propellers if other than as specified (see 3.14.1.3)
- (q) Required packing quantity (see 3.14.2.2.1).
- (r) When fiberboard box is required (see 3.14.2.2.1(b)(2)).
- (s) If table IV applies to skid base size members (see 3.15.6.2).
- (t) Propeller gauge boxes, if other than type W (see 3.17).
- (u) When the sample first article pack or item is to be subjected to the examination and tests of MIL-STD-2073-1C or this specification (see 4.2.2).
- (v) When rough handling tests are required (see 4.2.2.1).
- (w) If Material Safety Data Sheet required for preservation (see 6.8).

6.3 First article. When first article inspection is required, the contracting officer should provide specific guidance to offerors whether the items should be a first production item and the number of items to be tested as specified in 4.32. The contracting officer should also include specific instructions in acquisition documents regarding arrangements for examinations, approval of first article test results, and disposition of first articles. Invitations for bids should provide that the Government reserves the right to waive the requirement for samples for first article inspection to those bidders offering a product which has been previously acquired or tested by the Government, and that bidders offering such products, who wish to rely on such production or test, must furnish evidence with the bid that prior Government approval is presently appropriate for the pending contract. Bidders should not submit alternate bids unless specifically requested to do so in the solicitation.

6.4 Definitions. Definitions of preservation, packaging, and packing terms, including materials, processes, methods, and equipment will be found in MIL-STD-2073-1C.

6.4.1 Levels of protection. To help determine the extent of preservation required to protect an item against specific hazards of storage, transportation, and handling, the Department of Defense (DOD) has established two levels of protection whose main objectives are to provide uniform, efficient, and economical protection to supplies and equipment. The levels of protection are based upon the performance expected of the package. The performance criteria are summarized as follows.

6.4.1.1 Level A. This package provides maximum protection. It is needed to protect material under the most severe worldwide shipment, handling, and storage conditions. Preservation and packing will be designed to protect material against direct exposure to extremes of climate, terrain, and operational and transportation environments, without protection other than that provided by the pack. The conditions to be considered include, but are not limited to, the following:

- (a) Multiple handling during transportation and in transit storage from point of origin to final user.
- (b) Shock, vibration, and static loading during shipment
- (c) Loading on shipdeck, transfer at sea, helicopter delivery, and offshore or over-the-beach discharge to final user.
- (d) Environmental exposure during shipment or during in transit operations where port and warehouse facilities are limited or nonexistent.
- (e) Outdoor storage in all climatic conditions for a minimum of 1 year.
- (f) Static loads imposed by stacking.

For packing (exterior containers), it has been determined and agreed upon by the joint DOD packaging administrators that fiberboard and paperboard are not an acceptable material for use under level A packing for O-CONUS shipments.

6.4.1.2 Commercial. Although not specifically defined by any Government regulation or instruction, commercial packaging (preservation and packing) is understood to be those practices by manufacturers and suppliers to protect and identify material and items packaged for retail and wholesale distribution purposes. ASTM D 3951 provides guidance in the application of commercial packaging. It has been determined by joint DOD instructions that commercial (also in some areas addressed as industrial packaging) should only be used or specified when such packaging is known to satisfy the DOD needs. Such use should be determined before a contract for supplies is awarded or within the life cycle of the contract when substantial savings to the Government may result. Commercial (industrial) packaging should not be specified where multiple shipments and handling, long-term storage, or when such packaging is known to be insufficient to meet DoD needs are anticipated or desired.

6.4.2 Multiple-trip container. The design features of a multiple trip container are, subject to simple replacement of components, the container can be employed for more than one round trip from initial supply source to the consumer and return. A typical example is a demountable wooden box or crate equipped with fasteners permitting ready assembly, disassembly, and reassembly.

6.5 Asbestos. It is the intent of the Government to eliminate the use of asbestos except in those cases that a suitable alternative material cannot be used to obtain the desired results. In those cases in which components or

materials being packaged contain asbestos predominantly in their make-up, such items are to be separately packaged and marked (see 3.3.3 and 3.12).

6.6 Detailed information. Supplemental information on preservation and packing may be found in the following manuals:

FM38-700/MCO P4030.31D/NAVSUP PUB 502/AFJPAM 24-237/ DLAI 4145.14,
Packaging of Materiel, Preservation.

TM38-230-2/NAVSUP PUB 503/AFP 71-16/MCO P4030.21C, DLAI 4145.2, Packing
of Materiel

TM38-250/NAVSUP PUB 505/AFJMAN 24-204/MCO 4030.19G/DLAI 4145.3,
Preparing Hazardous Materials for Military Shipment

(Copies of these manuals may be obtained upon application to the Superintendent of Documents, US Government Printing Office, Washington, DC 20402.)

6.7 Packing and marking. Lots may be accepted or rejected in accordance with an acceptable quality level (AQL) of 2.5 percent defective.

6.8 Material safety data sheet (MSDS). Contracting officers will identify those activities requiring copies of MSDS's. Additional required Government information is contained in FED-STD-313. In order to obtain the MSDS, FAR clause 52.223-3 must be in the contract.

6.9 Subject term (key word) listing.

Controllable-pitch propeller
Monobloc
Multiple-trip container
Packing, commercial
Packing, level A
Preservation, commercial
Preservation, level A

6.10 Changes from previous issue. Marginal notations are not used in this revision to identify changes with respect to the previous issue due to the extent of the changes.



FIGURE 1. Propeller shipping frame (see 3.14.1.2.2.2 and 3.14.6.2).

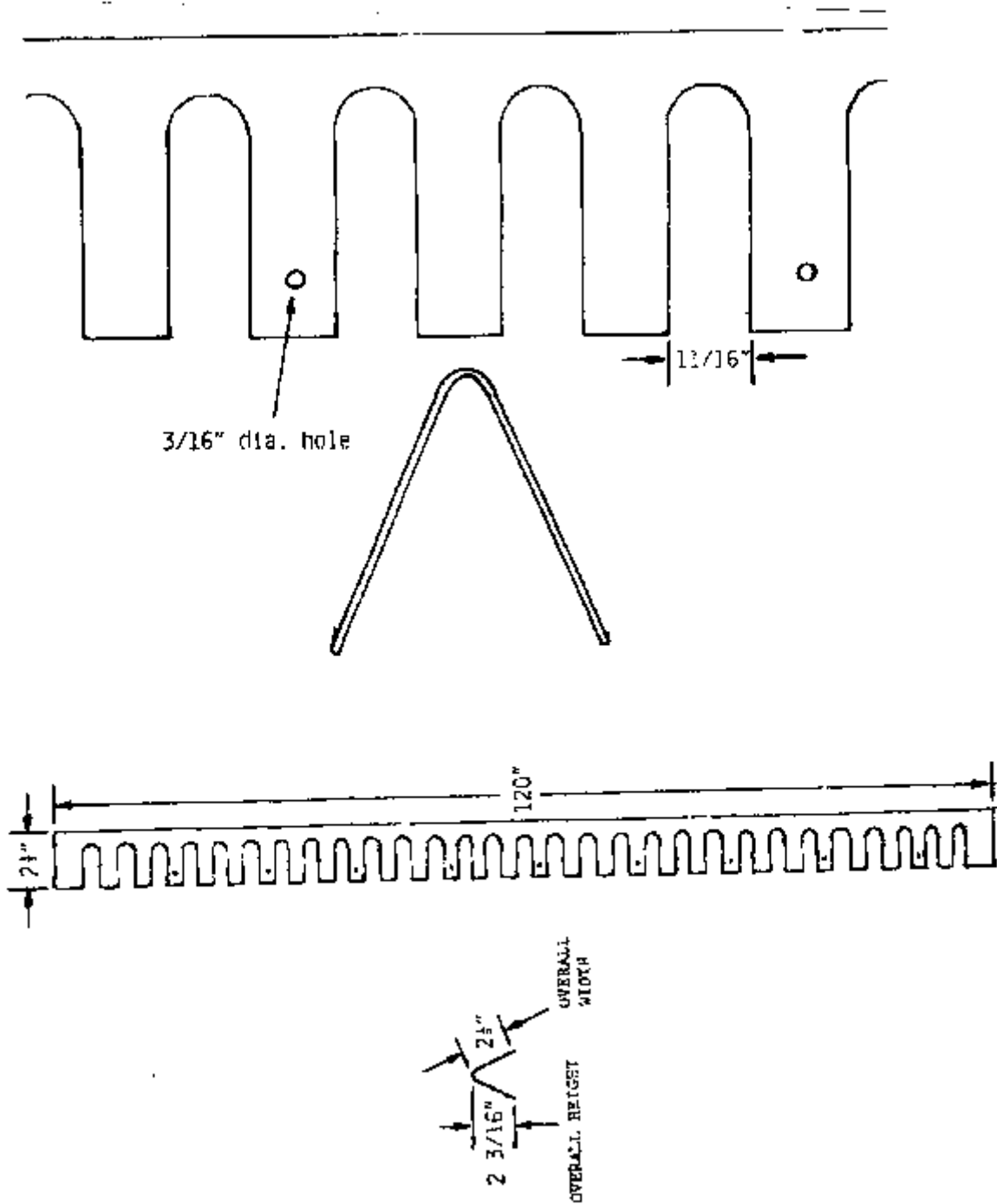
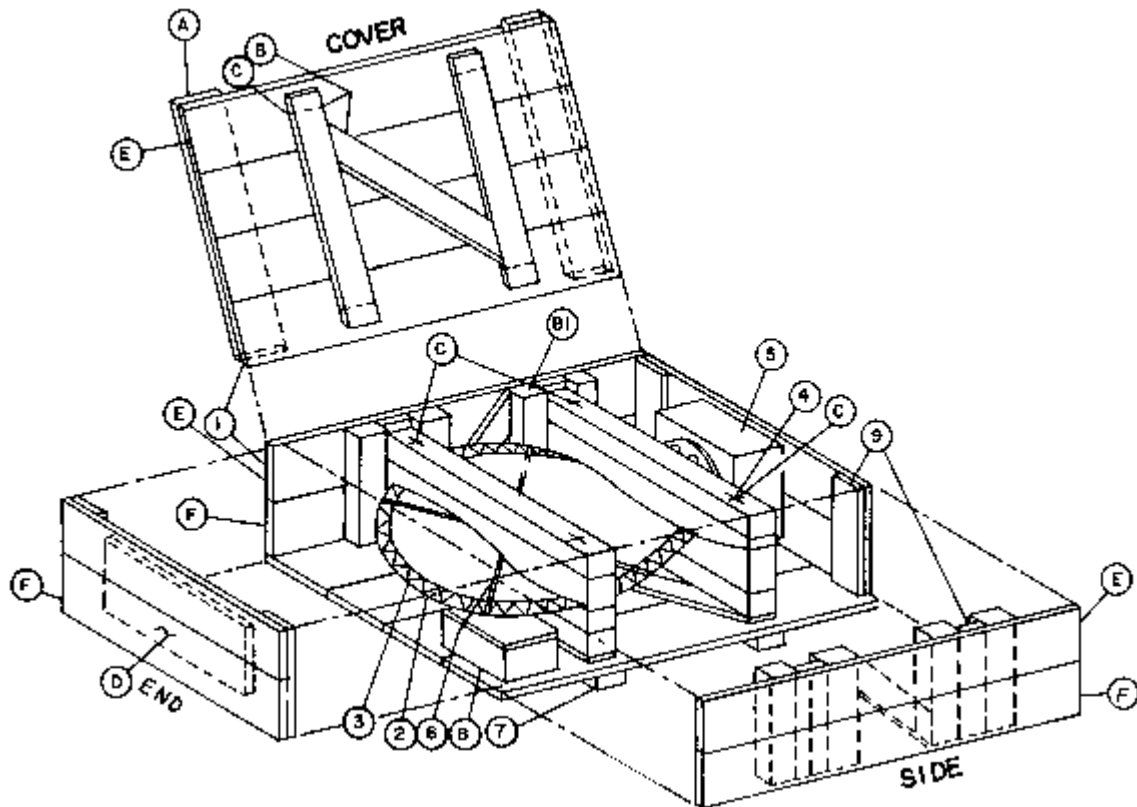

FIGURE 2. Propeller edge guards (see 3.14.1.4).

- A. Exterior cleats to prevent splitting of the ends of the cover members.
- B. Detail 4 is held in place by screwing through the sides and by pressure fit from the lid. End grain screwing is not recommended, hence the use of pocket cleats - B1 and the relocation of the diagonal on the lid.
- C. Another alternate to the pocket cleats - B1 would be the use of tie down bolts running from under the skid to the top block holding the contoured saddle. To make clearance for the bolts the cross member under the top must be cut back.
- D. To prevent severe end impact and give additional protection to the blade edge, a piece of minimum 3/4" plywood should be fastened on the inside of the end panel.



1. Box, type I, class I, style A, lengthwise sheathing 1-1/8" (30mm) wood planks.
2. Edge guards according to 3.14.1.4.
3. Canvas according to 3.14.1.4.
4. Contoured saddle, cushioned, 4-23/32" * 4-23/32" (120 * 120mm) wood beams.
5. Blocking device, wood piece.
6. Edge guard fastening (steel strap).
7. Skids 1-31/32" * 4-23/32" (50 * 120mm) wood beams.
8. Wood case for accessories, bolted to bottom.
9. Wood cleats, 1-3/16" * 4-23/32" (30 * 120mm).

FIGURE 3. Propeller blade packing (see 3.14.2.1).

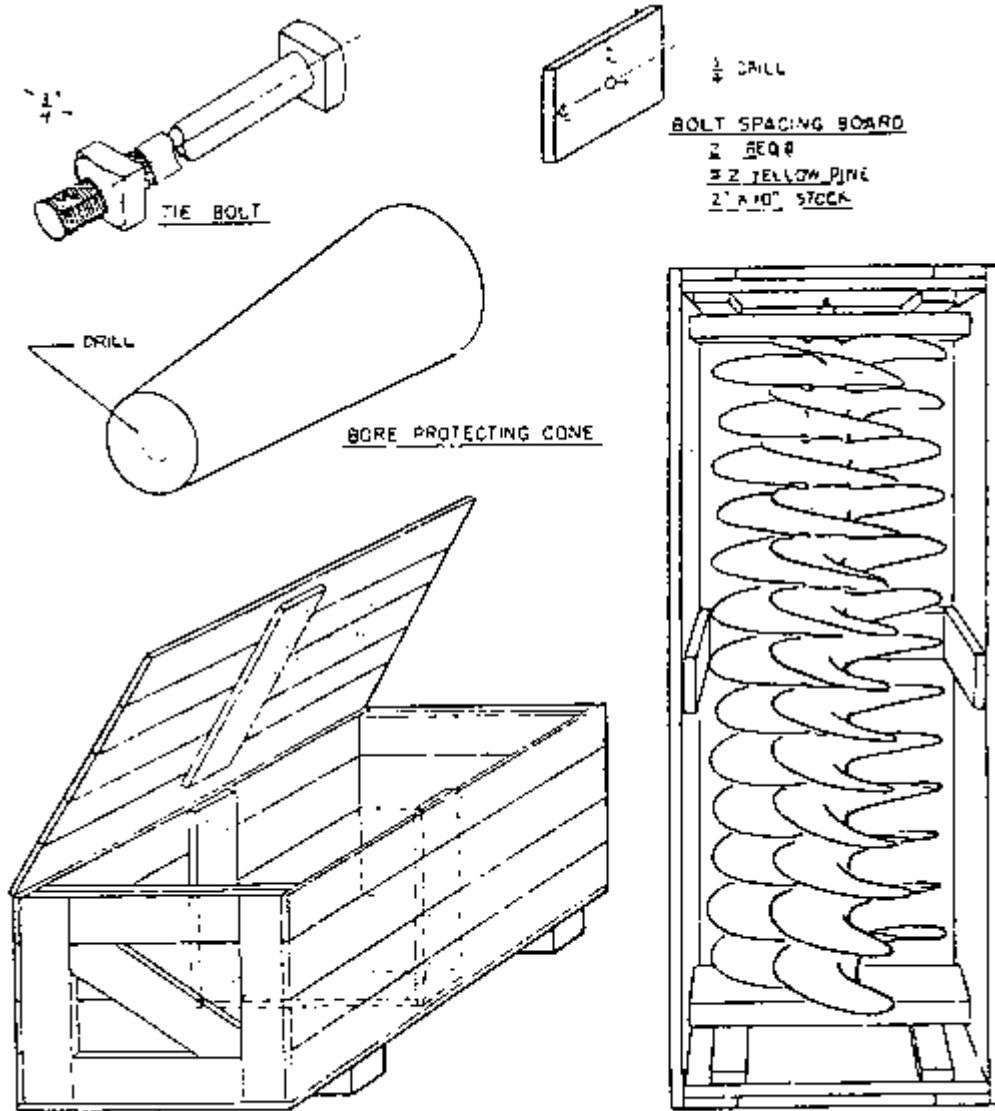

FIGURE 4. Box for boat propellers 30 inches in diameter and less (see 3.14.2.2.1).

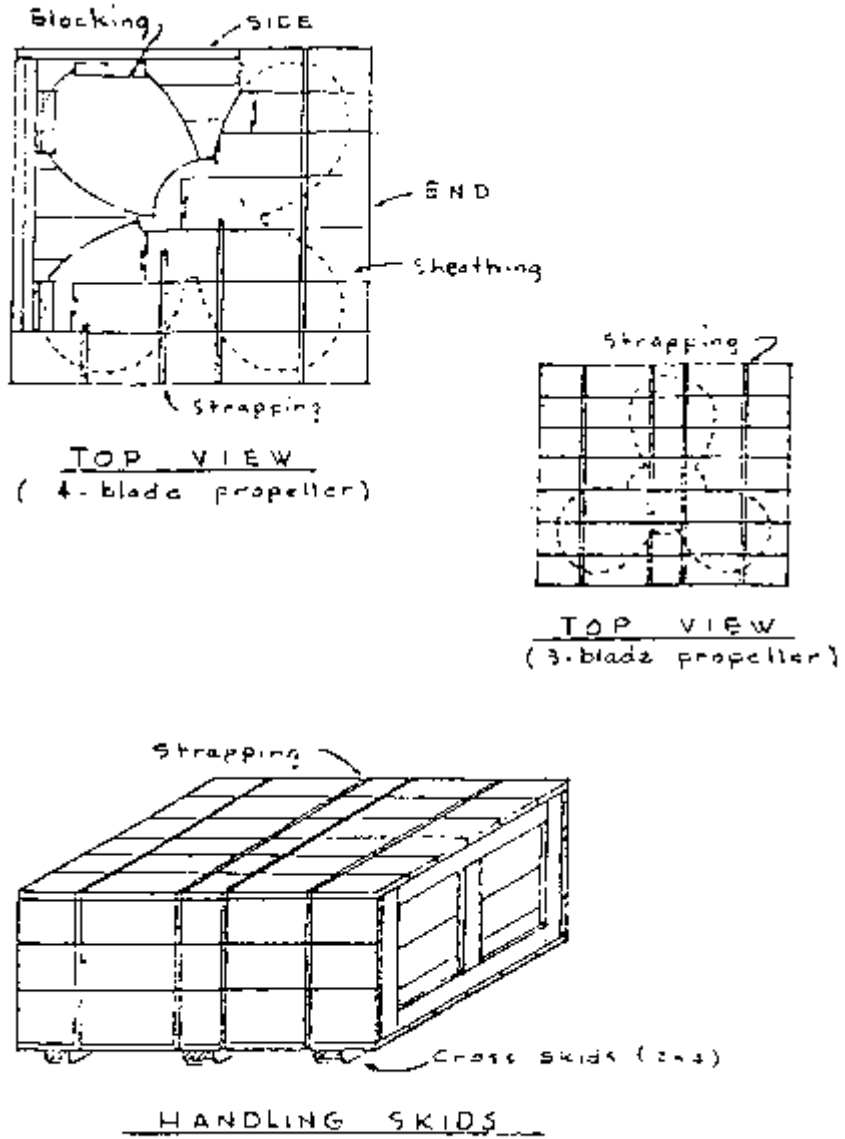

FIGURE 5. Wood box for propellers 30 inches in diameter and less (see 3.14.2.2.1).

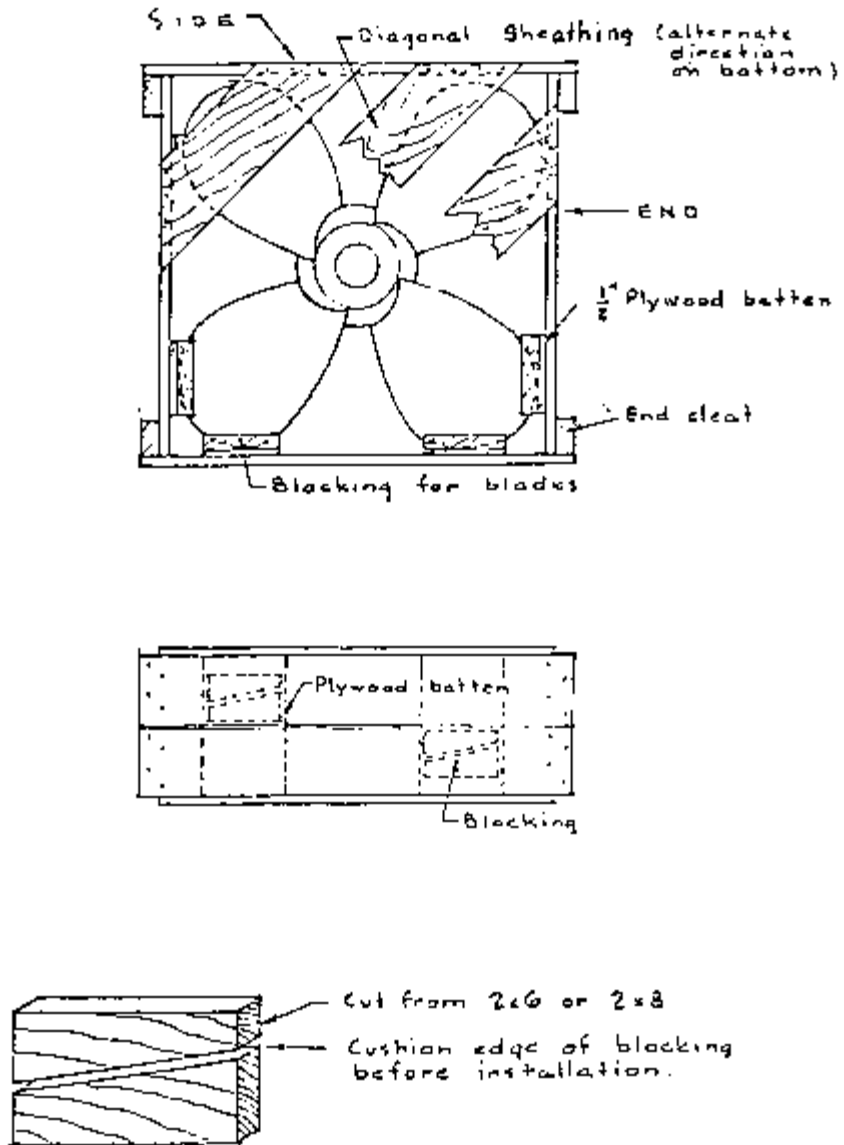

FIGURE 6. Blocking for propellers 30 inches in diameter and less(see 3.14.2.2.1).

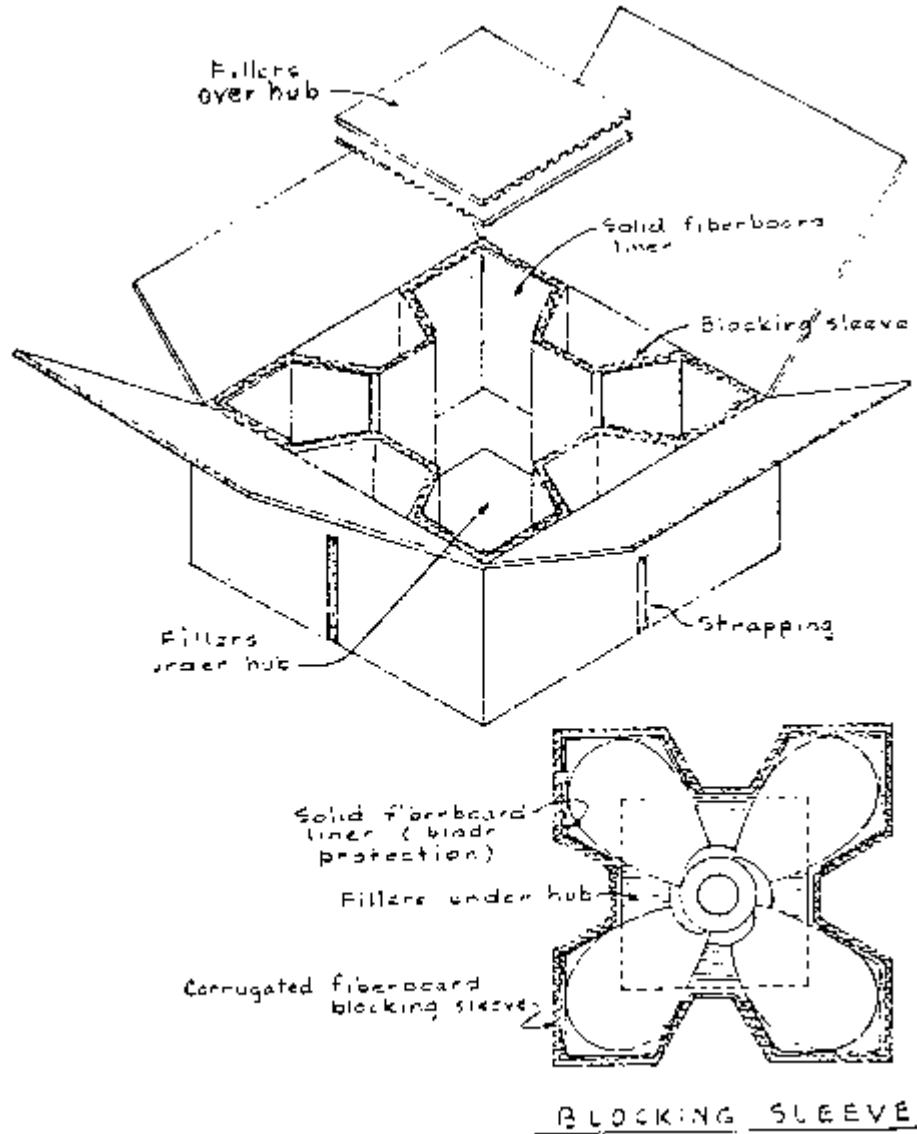

FIGURE 7. Fiberboard pack for propellers 30 inches in diameter and less (see 3.14.2.2.1).

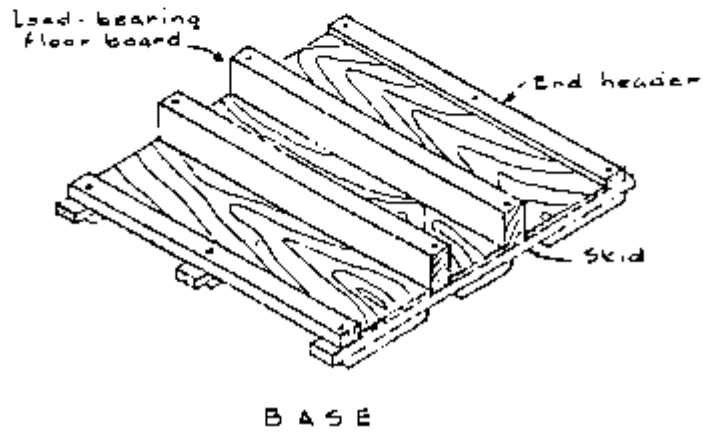
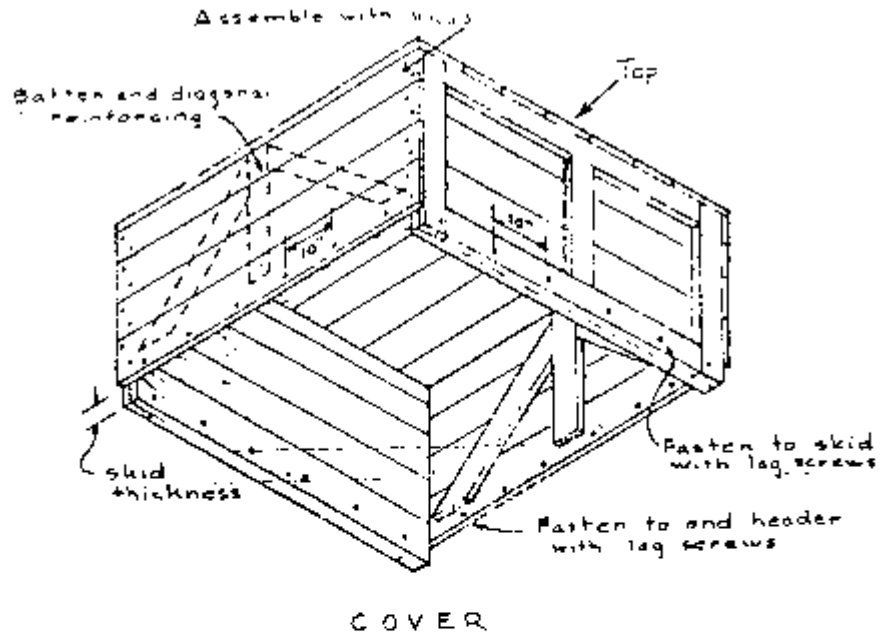

FIGURE 8. Cover and base (modified screwed-wood box) for propellers 30 to 60 inches in diameter (see 3.14.2.2.2).

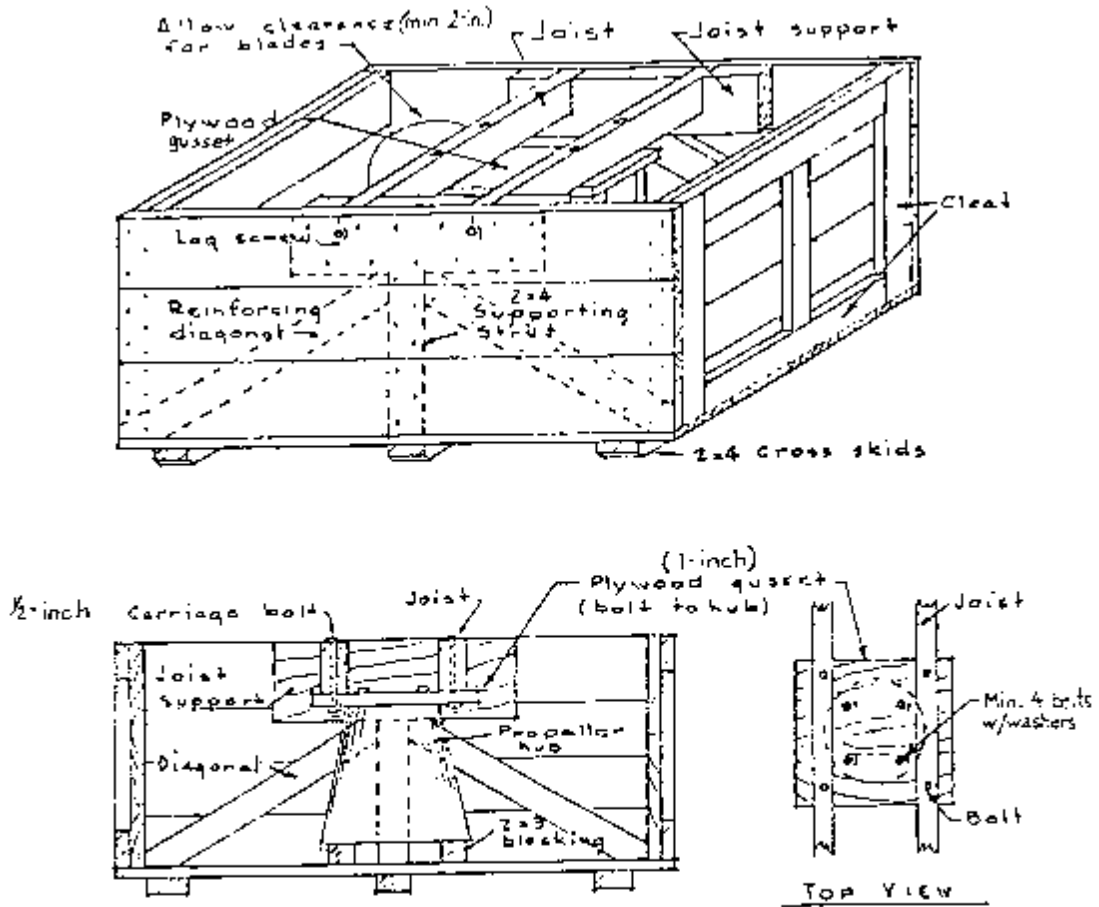

FIGURE 9. Wood box for propellers 30 to 60 inches in diameter, not greater than 600 pounds (see 3.14.2.2.2).

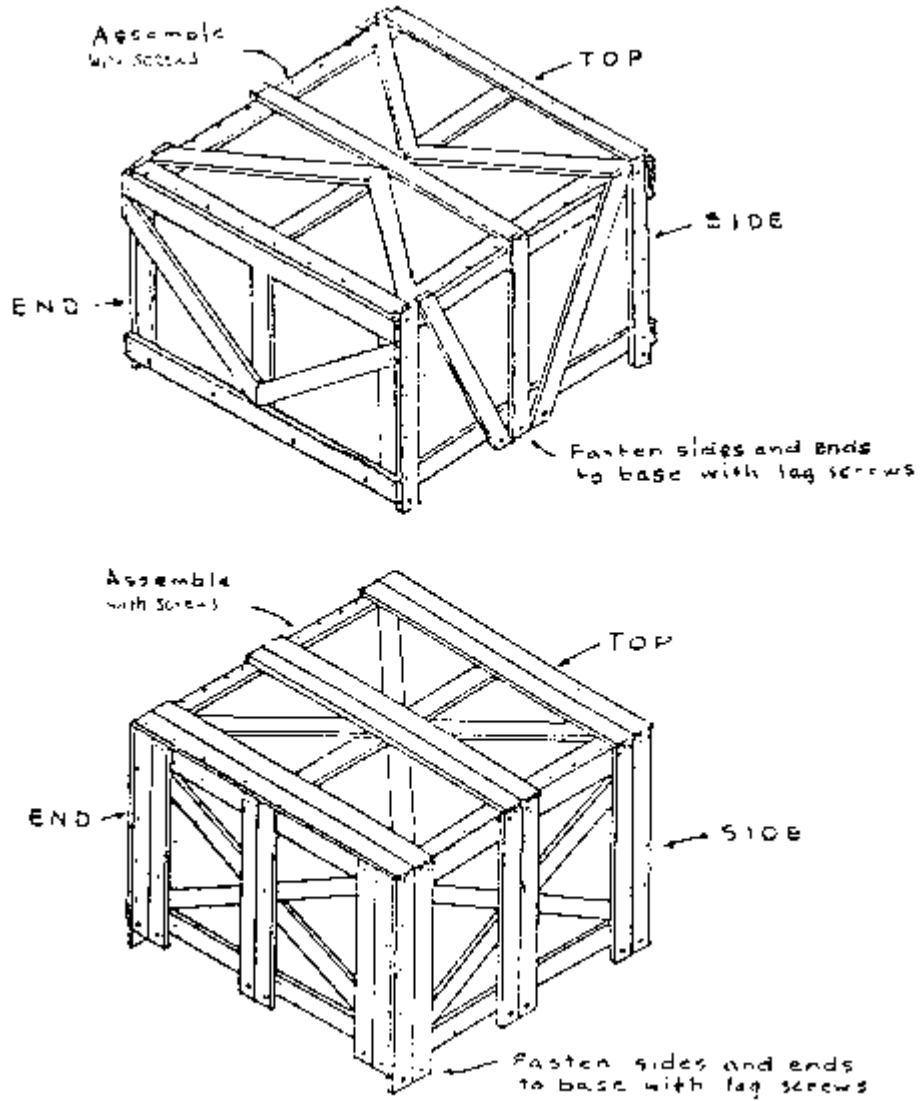

FIGURE 10. Open type crate covers for propellers 60 to 108 inches in diameter (see 3.14.2.2.2. and 3.14.2.2.3).

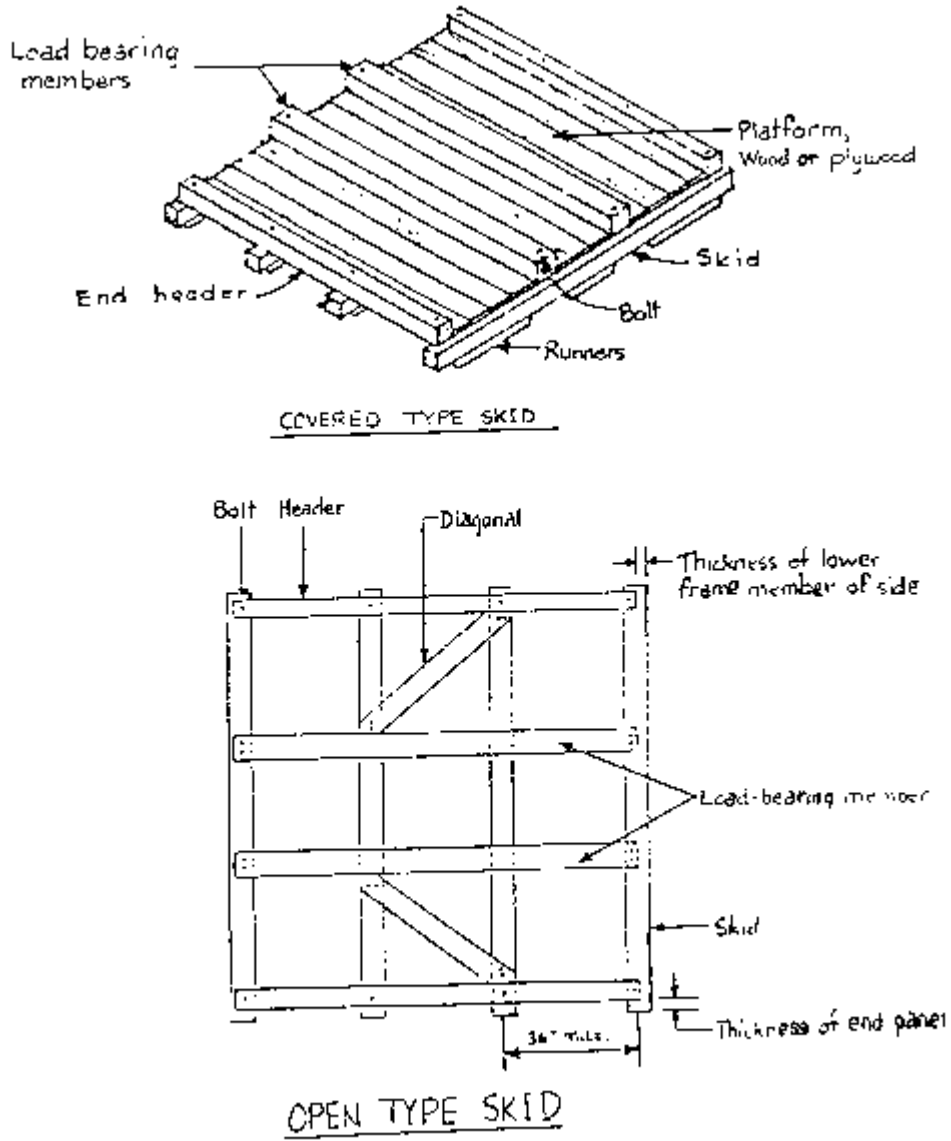

FIGURE 11. Skid-type bases for propellers 60 to 108 inches in diameter (see 3.14.2.2.3).

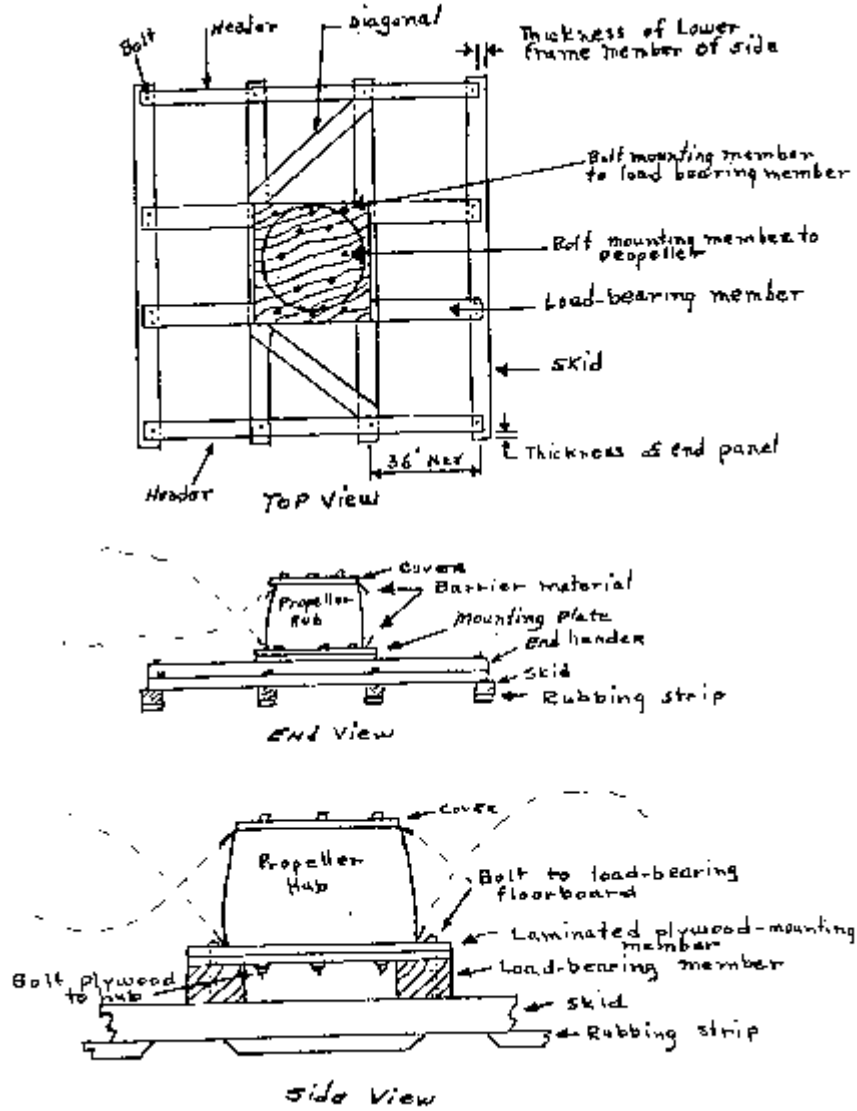

FIGURE 12. Propeller anchoring (see 3.14.2.2.3).

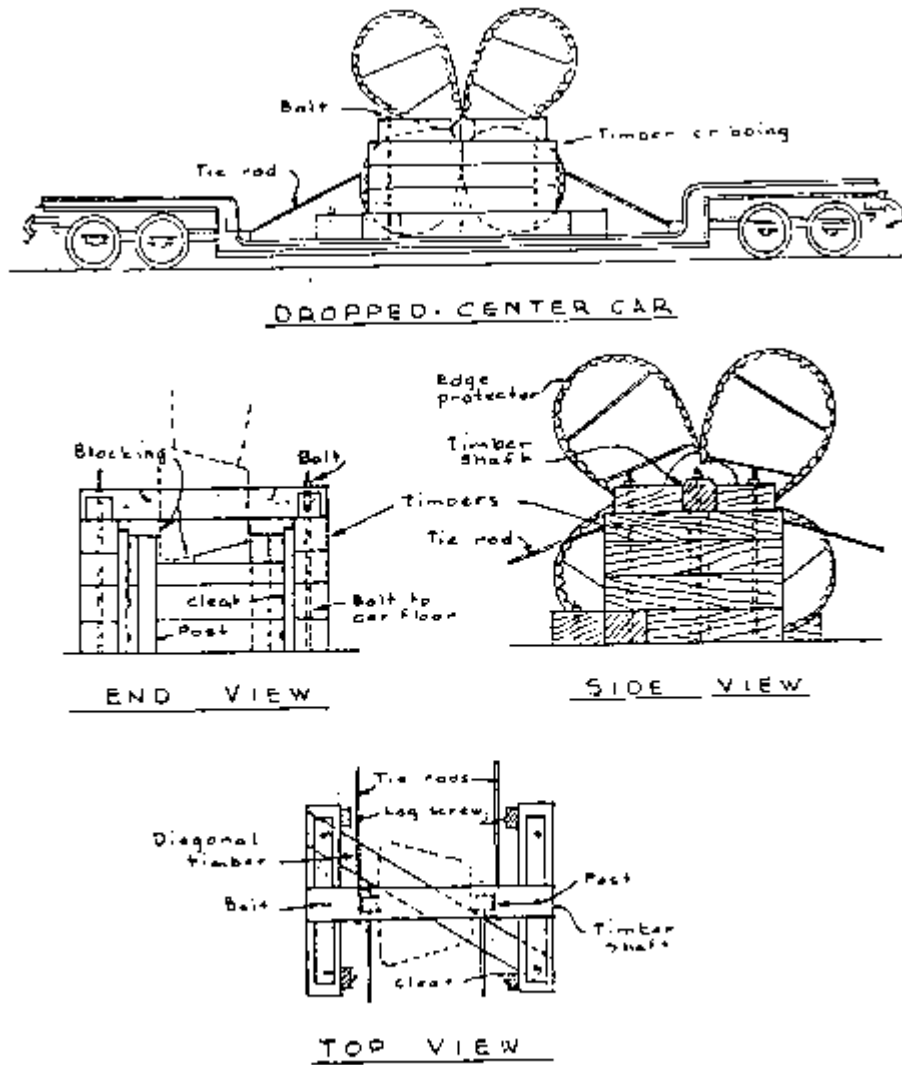

FIGURE 13. Blocking of large propeller (see 3.14.6.1).

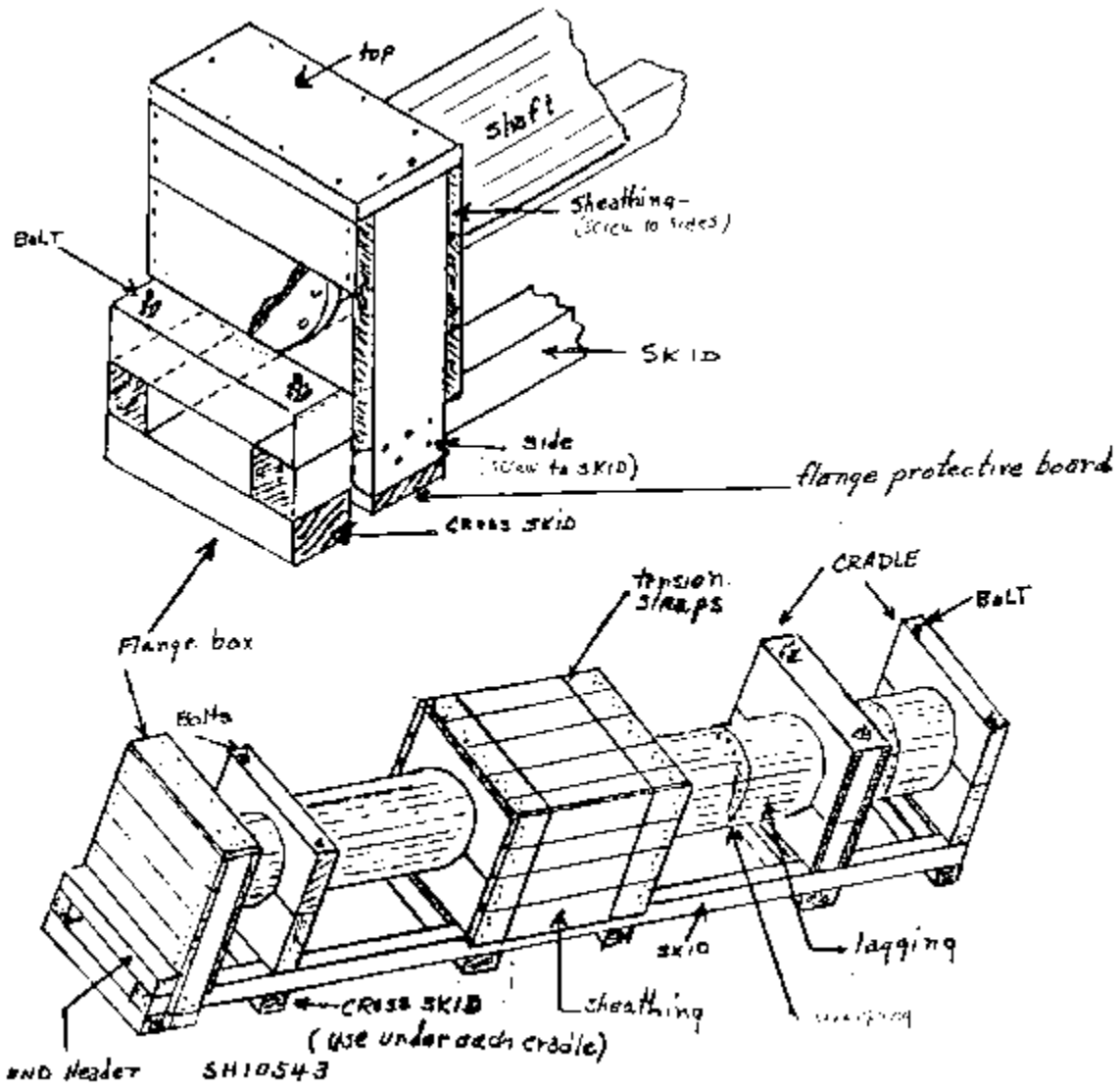

FIGURE 14. Skid assembly (composite view) for shafts greater than 3 inches in diameter (see 3.15.4.2 and 3.15.6.2).

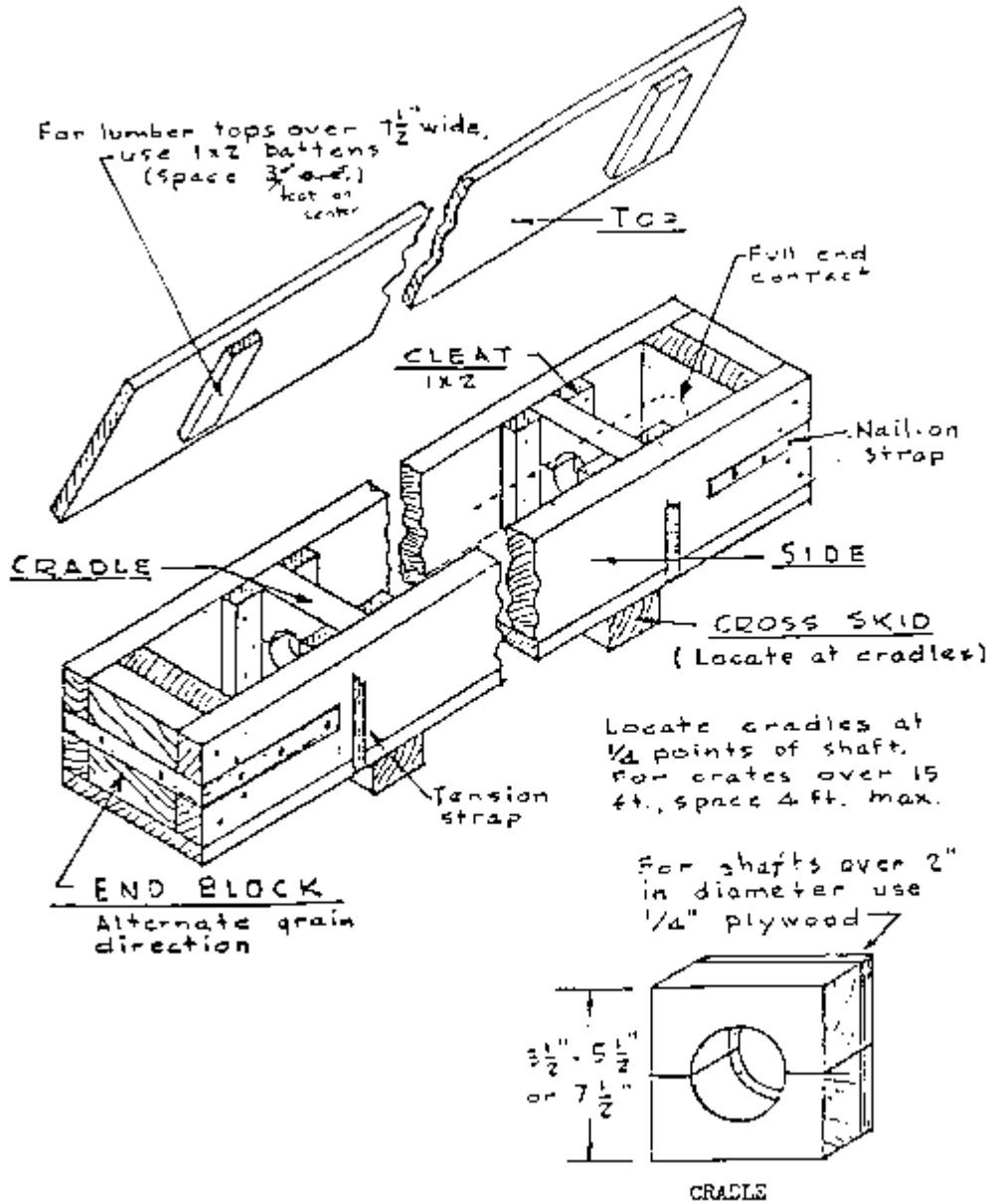

FIGURE 15. Wood box for shafting 3 inches in diameter and less (see 3.15.6.1).

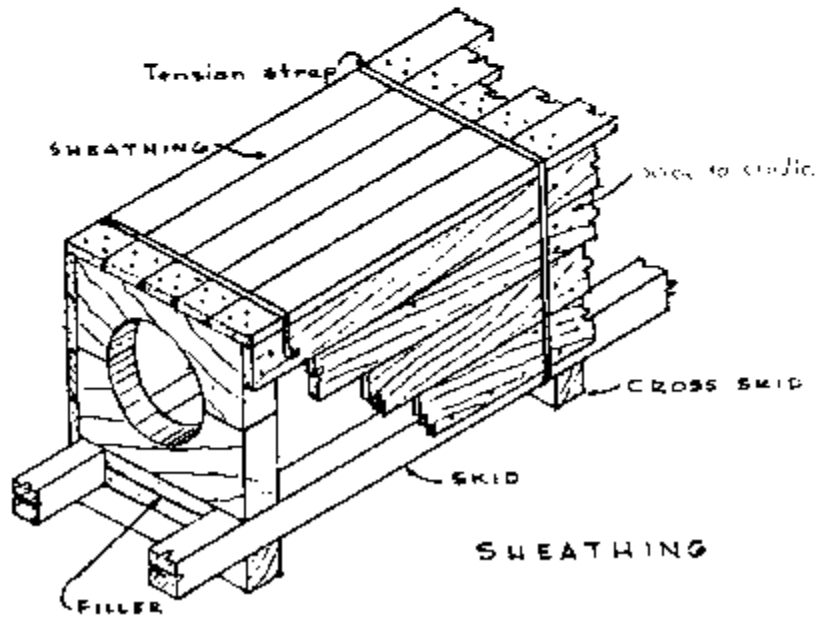
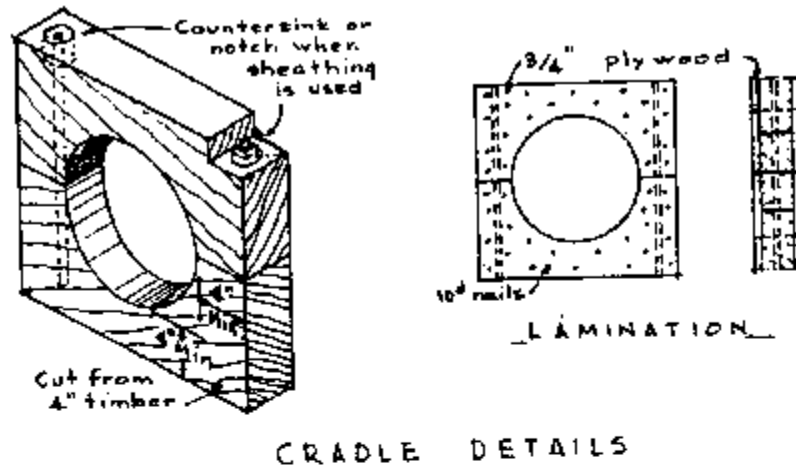

FIGURE 16. Skid assembly details (see 3.15.6.2).

1. Oil reservoir (expansion chamber).
2. Inspection window for checking oil level.
3. Flexible plastic pipe, clear.
4. Blocking device, 3-5/32" * 3 5/32" (80 * 80mm) wood beams.
5. Lengthwise sheathing 1-1/8" (30mm) wood planks.
6. Diagonal 3-5/32" * 3-5/32" (80 * 80mm) wood beams.
7. Oil-tight cover.
8. Flooring 1-1/8" (30mm) wood planks.
9. Cross-beams 5-33/64" * 5-33/64" (140 * 140mm).
10. Exterior battens 1-3/16" * 4-23/32" (30 * 120mm).

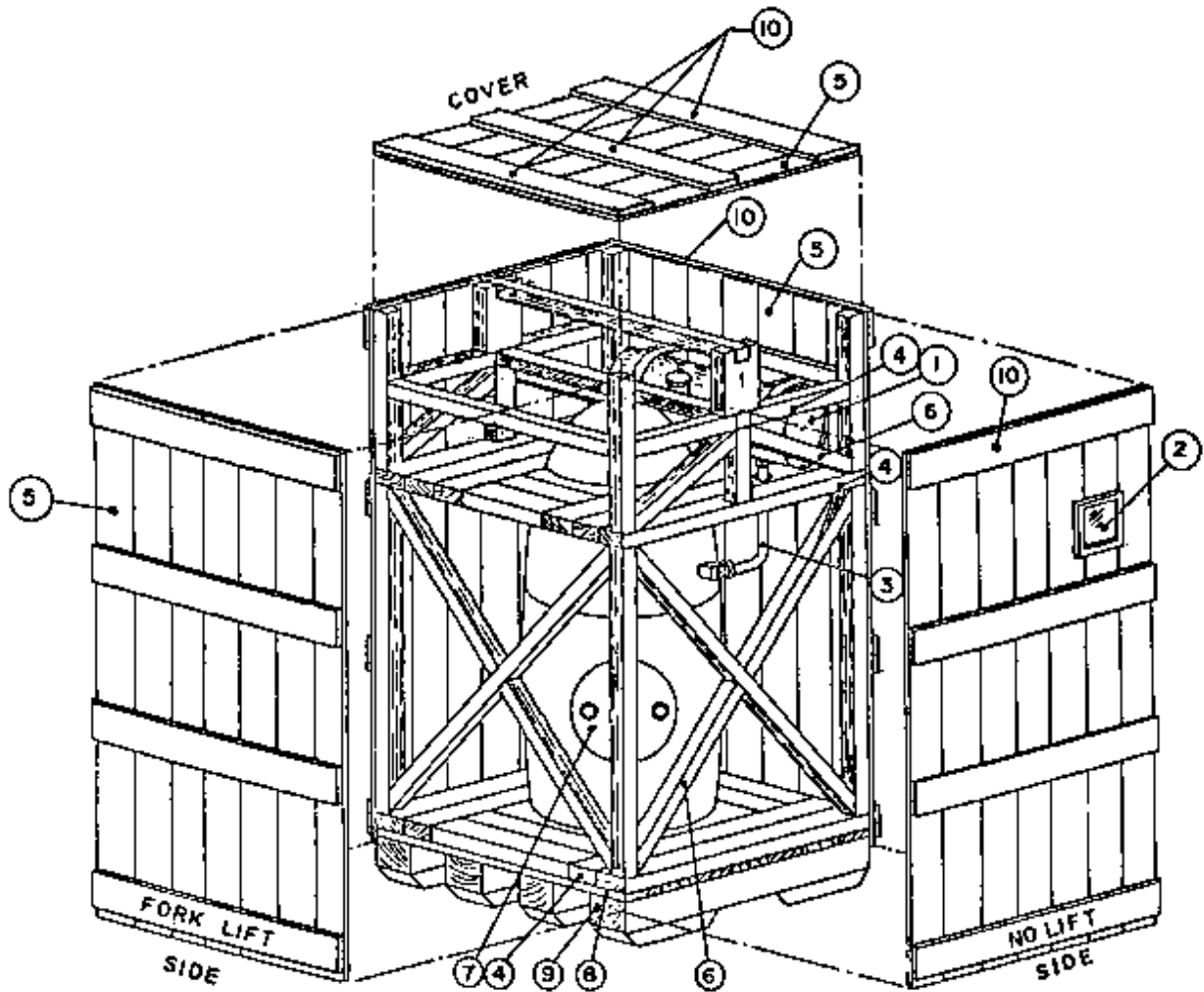
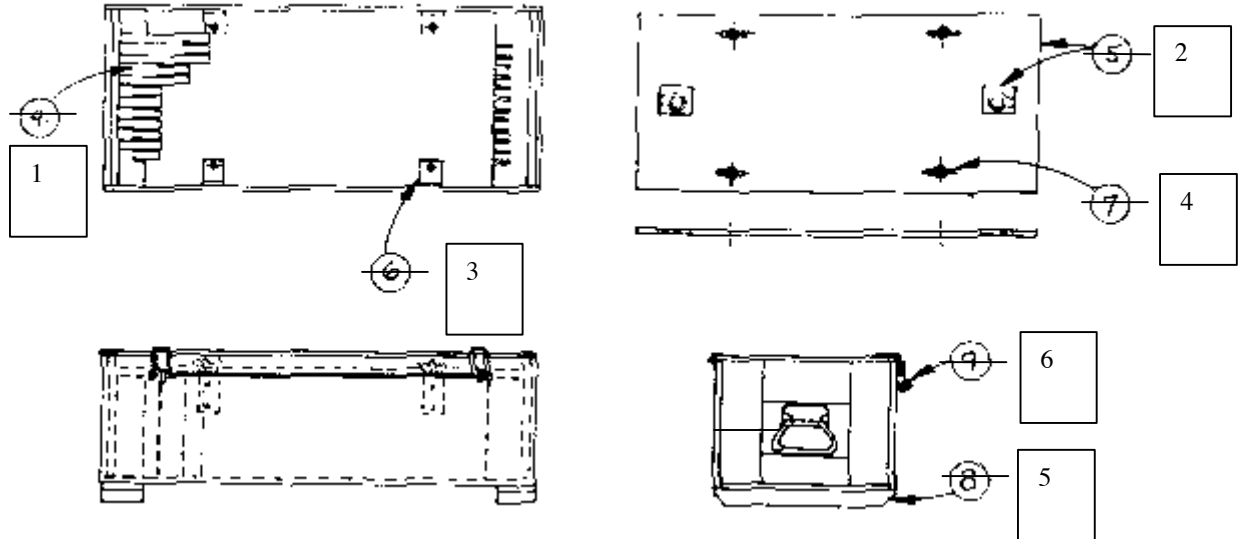

FIGURE 17. Hub packing (see 3.16.3).



41. Blade separator guides. Clearance between gauges shall permit ease of gauge removal
2. Trays, when included, shall be provided with lifting provision, handles, lift rings, or drilled holes for finger access.
3. Shelf brackets depicted are of metal "L" angles. Wood interior battens (framing) are also acceptable. See MIL-B-233 covering accessory framing and trays.
4. Shelf wing nut (4) locking device shown. Battens (framing) secured to the underside of the container cover to hold the shelf in place are also acceptable.
5. Wood skids in accordance with PPP-B-621 shall be included.
6. Snap-type trunk shown with locking bar.

NOTES:

1. Construction and materials in accordance with MIL-B-233, type W₇; wood container in accordance with PPP-B-621, style 2, 2-1/2, or 3 with style optional.
2. Rope handles not permitted.

FIGURE 18. Propeller gauge reusable container (see 3.17).

MIL-DTL-2845E (SH)

CONCLUDING MATERIAL

Preparing activity:
Navy - SH
(Project PACK-N060)

STANDARDIZATION DOCUMENT IMPROVEMENT PROPOSAL

INSTRUCTIONS

1. The preparing activity must complete blocks 1, 2, 3, and 8. In block 1, both the document number and revision letter should be given.
2. The submitter of this form must complete blocks 4,5,6, and 7 and send to preparing activity.
3. The preparing activity must provide a reply within 30 days from receipt of the form.

NOTE: This form may not be used to request copies of documents, nor to request waivers, or clarification of requirements on current contracts. Comments submitted on this form do not constitute or imply authorization to waive any portion of the referenced document(s) or to amend contractual requirements.

I RECOMMEND A CHANGE:

1. DOCUMENT NUMBER
MIL-DTL-2845

2. DOCUMENT DATE (YYYYMMDD)
19990818

3. DOCUMENT TITLE: PROPULSION SYSTEMS, BOAT AND SHIP; MAIN SHAFTING, PROPELLERS, BEARINGS, GAUGES, SPECIAL TOOLS, AND ASSOCIATED REPAIR PARTS; PRESERVATION, PACKAGING, PACKING AND STORAGE OF

4. NATURE OF CHANGE (*Identify paragraph number and include proposed rewrite, if possible. Attach extra sheets as needed*)

5. REASON FOR RECOMMENDATION

6. SUBMITTER

a. NAME (*Last, First, Middle Initial*)

b. ORGANIZATION

c. ADDRESS (*Include Zip Code*)

d. TELEPHONE (*Include Area Code*)
(1) Commercial
(2) DSN
(*if applicable*)

7. DATE SUBMITTED
(YYYYMMDD)

8. PREPARING ACTIVITY

a. NAME
SEA O3Q

b. TELEPHONE (*Include Area Code*)
(1) Commercial (703) 602-1828x114
(2) DSN 332-1828

c. ADDRESS (*Include Zip Code*)
Commander, Naval Sea Systems Command
ATTN: SEA O3Q, 2531 Jefferson Davis Hwy
Arlington, VA 22242-5160

IF YOU DO NOT RECEIVE A REPLY WITHIN 45 DAYS, CONTACT:
Defense Standardization Program Office (DLSC-LM)
8725 John J. Kingman Road, Suite 2533,
Fort Belvoir, VA 22060-6221
Telephone (703) 767-6888 DSN 427-6888