



Standard Practice for Silt Fence Installation¹

This standard is issued under the fixed designation D 6462; the number immediately following the designation indicates the year of original adoption or, in the case of revision, the year of last revision. A number in parentheses indicates the year of last reapproval. A superscript epsilon (ϵ) indicates an editorial change since the last revision or reapproval.

1. Scope*

1.1 This practice covers common installation requirements for temporary silt fence applications. This practice is based on AASHTO M288.

1.2 This practice is applicable to the use of silt fence as a vertical permeable interceptor designed to remove suspended soil from overland, nonconcentrated water flow. The function of a temporary silt fence is to trap and allow settlement of soil particles from sediment laden water. The purpose is to greatly limit the transport of eroded soil from the construction site by water runoff.

1.3 The practices presented herein are intended to ensure good workmanship and quality and are not necessarily adequate for all purposes in view of the wide variety of possible sediments and performance objectives.

1.4 The values stated in SI units are to be regarded as the standard. The values in inch-pound units are provided for information only.

1.5 *This practice offers an organized collection of information or a series of options and does not recommend a specific course of action. This document cannot replace education or experience and should be used in conjunction with professional judgment. Not all aspects of this guide may be applicable in all circumstances. This ASTM standard is not intended to represent or replace the standard of care by which the adequacy of a given professional service must be judged, nor should this document be applied without consideration of a project's many unique aspects. The word "Standard" in the title of this document means only that the document has been approved through the ASTM consensus process.*

1.6 *This standard does not purport to address all of the safety concerns, if any, associated with its use. It is the responsibility of the user of this standard to establish appropriate safety and health practices and determine the applicability of regulatory limitations prior to use.*

2. Referenced Documents

2.1 ASTM Standards:

D 653 Terminology Relating to Soil, Rock, and Contained Fluids²

D 3740 Practice for Minimum Requirements for Agencies Engaged in the Testing and/or Inspection of Soil and Rock as Used in Engineering Design and Construction²

D 4632 Test Method for Grab Breaking Load and Elongation of Geotextiles³

D 6461 Specification For Silt Fence Materials⁴

2.2 AASHTO Standard:

M288-96 Standard Specification for Geotextile Specification for Highway Applications⁵

3. Terminology

3.1 For definitions of terms used in this practice, see Terminology D 653.

4. Significance and Use

4.1 Proper installation is critical to effective performance of silt fence. This practice presents procedures for installing silt fence that have been shown to result in silt fence installations that effectively redirect and impound surface runoff and, thereby, provide effective sediment control.

5. Controlling Material Specifications

5.1 All materials used for temporary silt fence shall conform with the specification requirements of ASTM Specification D 6461 unless otherwise specified in the controlling project specifications.

6. Certification

6.1 The contractor shall provide to the engineer all certifications required by the controlling material specification.

¹ This practice is under the jurisdiction of ASTM Committee D18 on Soil and Rock and is the direct responsibility of Subcommittee D18.25 on Erosion and Sediment Control Technology.

Current edition approved July 10, 2003. Published September 2003. Originally approved in 1999. Last previous edition approved in 1999 as D 6462-99.

² *Annual Book of ASTM Standards*, Vol 04.08.

³ *Annual Book of ASTM Standards*, Vol 04.13.

⁴ *Annual Book of ASTM Standards*, Vol 04.09.

⁵ Available from AASHTO.

*A Summary of Changes section appears at the end of this standard.

7. Sampling, Testing, and Acceptance

7.1 Silt fence materials shall be subject to sampling and testing in accordance with and to verify conformance with the controlling material specification.

8. Silt Fence Installation

8.1 *Materials*—Silt fence materials shall conform to the requirements of Section 5. Unless otherwise specified, the silt fence installation shall conform to the following:

8.1.1 The geotextile used for temporary silt fence may or may not be supported between posts with wire or polymeric mesh.

8.1.2 The minimum height above ground for the silt fence shall be 600 mm (2.0 ft). Minimum embedment depth shall be 150 mm (0.5 ft).

8.1.3 Maximum post spacing shall be based on the fabric support or, if unsupported, on elongation as measured in accordance with Test Method D 4632. Supported silt fence shall have a maximum post spacing of 1.2 m (4 ft). Unsupported silt fence with elongation $\geq 50\%$ shall also have a maximum post spacing of 1.2 m (4 ft). Unsupported silt fence with elongation $< 50\%$ shall have a maximum post spacing of 2 m (6.5 ft).

8.1.4 Wood, steel, or synthetic support posts having a minimum length of 1 m (3.3 ft) plus the burial depth may be used. They shall be of sufficient strength to resist damage during installation and to support the applied loads due to material build up behind the silt fence.

NOTE 1—It has been found that hardwood posts having dimensions of at least 30 × 30 mm (1.2 × 1.2 in.), No. 2 Southern Pine at least 65 × 65 mm (2.5 × 2.5 in.) or steel posts of UTL or C shape, weighing 600 g per 300 mm (1.3 lb/ft) have performed satisfactorily.

8.1.5 Wire or polymer support fence shall be at least 750 mm (2.5 ft) high and strong enough to support applied loads. Polymer support fences shall meet the same ultraviolet degradation requirements as the geotextile.

NOTE 2—Wire support fence having at least 6 horizontal wires, and being at least 14 gage wire have performed satisfactorily. Vertical wires should be a maximum of 150 mm (0.5 ft) apart.

8.2 Construction:

8.2.1 *Trench Construction*—The bottom of the silt fence geotextile shall be buried in a “J” configuration to a minimum depth of 150 mm (6 in.) in a trench so that no flow can pass under the silt fence. Backfill the trench and compact the soil over the geotextile so that the compacted soil completely fills the trench. (See Fig. 1.)

8.2.2 *Soil Slicing Construction*—Insert the geotextile in a slit in the soil 0.2 to 0.3 m (8 to 12 in.) deep so that no flow can pass under the silt fence. Create the slit such that a horizontal chisel point (approx. 76 mm/3 in. wide) at the base of a soil slicing blade (approx. 18 mm/0.75 in. wide) slightly disrupts soil upward as the blade slices through the soil. This upward disruption minimizes horizontal compaction and creates an optimal soil condition for mechanical compaction against the geotextile. Mechanically insert the geotextile directly behind the soil slicing blade in a simultaneous operation, achieving consistent placement and depth. (See Fig. 2.)

8.2.3 Splice the geotextile together only at support posts. Two sections of fence may be overlapped or alternatively spliced as long as there are no gaps, voids, or other loss of integrity of the barrier.

8.2.4 Place the posts at spacing as shown on the project plans. Drive posts or place a minimum of 500 mm (1.65 ft) into the ground. Increase depth to 600 mm (2 ft) if fence is placed on a slope of 3H:1V or greater.

NOTE 3—Where 500 mm (1.65 ft) depth is impossible to attain, the posts should be adequately secured to prevent overturning of the fence due to sediment loading.

8.2.5 Fasten the support fence securely to the upslope side of the fence post. The support fence shall extend from the ground surface to the top of the geotextile.

8.2.6 When self-supported fence is used, securely fasten the geotextile to fence posts.

8.2.7 Silt fences should be continuous and transverse to the flow. The silt fence should follow the contours of the site as closely as possible. Place the fence such that the water cannot runoff around the end of the fence.

NOTE 4—Commonly, silt fence is limited to handle an area equivalent to 90 m²/3 m (100 ft²/10 ft) of fence. Caution is used where the site slope

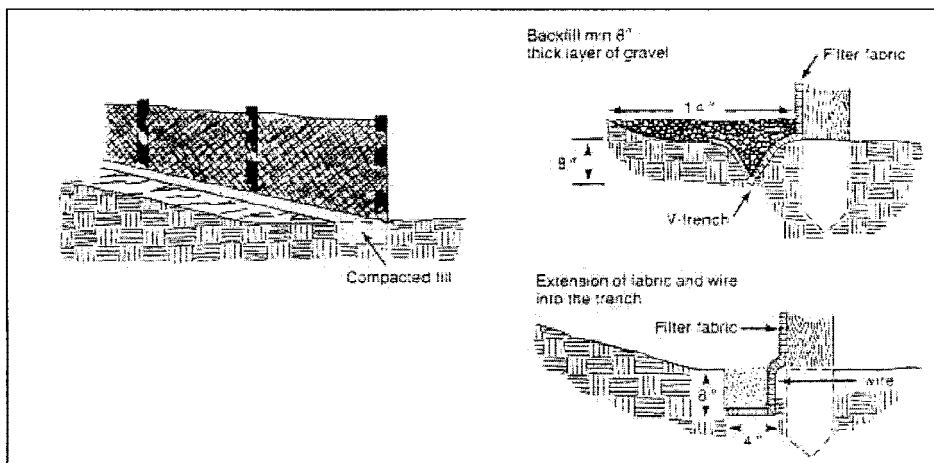

FIG. 1 Typical Silt Fence Installation Detail

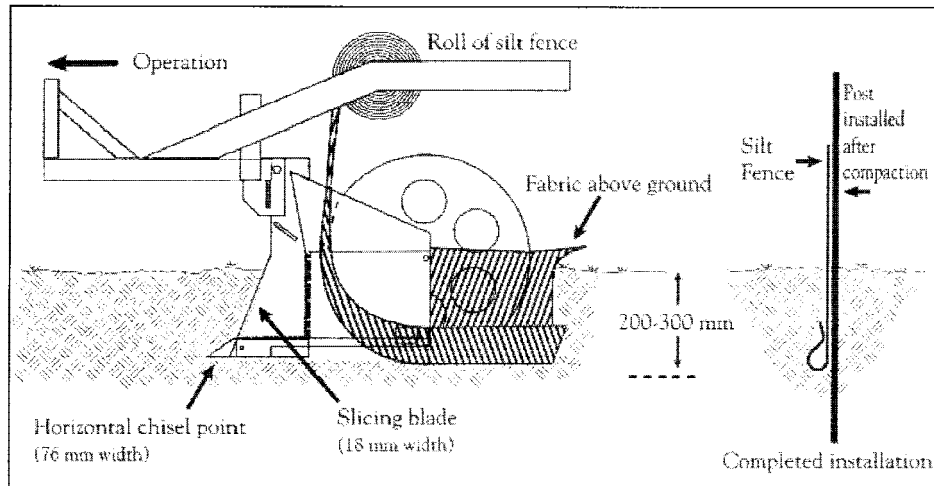

FIG. 2 Typical Silt Fence Installation Using Soil Slicing

is greater than 1H: 1V, and water flow rates exceed 3 L/s/3 m (50 gal/min/10 ft) of fence.

8.2.8 *Compaction*—When assembling silt fence on-site, compaction prior to installing posts is recommended. Compact the backfill soil immediately next to the silt fence geotextile. Compact the upstream side first, and then the downstream side. When installing pre-assembled silt fence, care shall be taken to sufficiently compact soil adjacent to the installed geotextile and posts. The soil adjacent to the buried silt fence geotextile shall be compacted to achieve no less than 50% of its original insitu strength when measured using a suitably calibrated hand-held penetrometer or shear vane, unless a more appropriate compaction measurement technique and associated compaction criteria is directed by the engineer.

NOTE 5—Installed posts may interfere with compaction by large equipment adjacent to the silt fence. Compaction is commonly accomplished with the front wheel of a tractor, skid steer, roller or other device, as well as with manual tamping or other manual means.

8.3 *Maintenance:*

8.3.1 The contractor shall inspect all temporary silt fences immediately after each rainfall, and at least daily during prolonged rainfall. Any deficiencies shall be immediately corrected by the contractor.

8.3.1.1 The contractor shall also make a daily review of the location of silt fences in areas where construction activities have altered the natural contour and drainage runoff to ensure that the silt fences are properly located for effectiveness. Where deficiencies exist as determined by the engineer, additional silt fence shall be installed as directed by the engineer.

8.3.1.2 Repair damaged or otherwise ineffective silt fences or replace promptly.

8.3.2 Either remove sediment deposits when the deposit reaches half the height of the fence, or install a second silt fence as directed by the engineer.

8.3.3 The silt fence shall remain in place until the engineer directs it be removed. Upon removal the contractor shall remove and dispose of any excess sediment accumulations, dress the area to give it a pleasing appearance, and vegetate all bare areas in accordance with contract requirements.

8.3.3.1 Removed silt fence may be used at other locations provided the geotextile and other material requirements continue to be met to the satisfaction of the engineer.

9. **Keywords**

9.1 geotextile; silt fence; sediment control

SUMMARY OF CHANGES

In accordance with Committee D18 policy, this section identifies the location of changes tot his standard since the last edition (99) that may impact the sue of this standard.

- (1) Added the professional judgement caveat to Scope Section.
- (2) Added Terminology D 653 and Practice D 3740 to Referenced Documents Section.
- (3) Added Terminology Section and included Terminology D 653.
- (4) Added Significance and Use Section.
- (5) Renumbered subsequent sections.
- (6) Corrected Specification reference to D 6461 in 5.1.
- (7) Changed heights in 8.1.2.
- (8) Clarified trench construction in 8.2.3.
- (9) Added spicing details to 8.2.3.
- (10) Expanded compaction requirements in 8.2.8.
- (11) Added to Note 5.
- (12) Added Keyword Section.
- (13) Added Summary of Changes Section.

ASTM International takes no position respecting the validity of any patent rights asserted in connection with any item mentioned in this standard. Users of this standard are expressly advised that determination of the validity of any such patent rights, and the risk of infringement of such rights, are entirely their own responsibility.

This standard is subject to revision at any time by the responsible technical committee and must be reviewed every five years and if not revised, either reapproved or withdrawn. Your comments are invited either for revision of this standard or for additional standards and should be addressed to ASTM International Headquarters. Your comments will receive careful consideration at a meeting of the responsible technical committee, which you may attend. If you feel that your comments have not received a fair hearing you should make your views known to the ASTM Committee on Standards, at the address shown below.

This standard is copyrighted by ASTM International, 100 Barr Harbor Drive, PO Box C700, West Conshohocken, PA 19428-2959, United States. Individual reprints (single or multiple copies) of this standard may be obtained by contacting ASTM at the above address or at 610-832-9585 (phone), 610-832-9555 (fax), or service@astm.org (e-mail); or through the ASTM website (www.astm.org).