

Complete Guide to **MEASURING MOISTURE** IN FLOORING SYSTEMS



DELMHORST.
INSTRUMENT CO.
WHEN ACCURACY IS THE POINT.™

DELMHORST E-GUIDE

Table of Contents

What is the Right Type of Moisture Meter for You?	5
Moisture Measurement in Concrete	9
ASTM F2170-11 (for Concrete Slabs) At a Glance	11
Moisture Measurement for Wood Flooring	13
Moisture Measurement in Restoration	14
Conclusion	16

Introduction

Who Benefits from Using Moisture Meters

A vast number of industries across America routinely rely upon moisture meters to conduct their daily operations and ensure job quality and success. Undesirable levels of moisture in a flooring system which include surface material, sub floors, underlayment, and concrete slab can undermine an entire new construction or restoration project. Getting an accurate moisture reading can make or break a job and profits. Nothing but accuracy will do and using the right tool on the right job is an important component for success.



Delmhorst Instrument Co. is a private US company dedicated to manufacturing all of our moisture meters in the United States. Our dedication to durability, high quality and exceptional service has made us a leader in this field for over 65 years. We have provided this guide for an overview of what moisture meter to use and why – when **moisture measuring is required**.

General Contractors

As concrete is a primary building material, measuring the moisture content when installing a concrete subfloor is a critical factor in the construction of office buildings, big box stores, residential structures, medical centers and more. Excessive moisture in the subfloor can cause overlay and finished flooring to warp or buckle. Often this occurs after tenants occupy the building, resulting in an expensive, unwanted and reputation-damaging need for remediation.

Other contractors work with hardwoods, softwoods, air-dried or kiln-dried and hybrid wood products. Moisture levels in these raw materials are equally as important as in the sub-floors and incorrect levels can impact the structural integrity, performance and aesthetics of a job long after you have left the site.

Finally, since builders and contractors must rely on accurate moisture readings every day, day in and day out, meter durability is equally as important. These meters get a workout on active construction sites. For a contractor working on multiple complex projects, quick access to top notch technical support can factor into which moisture measuring equipment to buy.

Restoration Specialists

When disaster strikes, the structural, financial and emotional damage can be devastating. That's why moisture meters are so critical in restoration work. Floods, fires, and even remodels or restoration of older homes require special attention to measuring moisture levels. Some water intrusion damage will be permanent, some of it is repairable. Moisture meters are the most cost effective way to measure moisture for restoration specialists. Many restoration contractors use an infrared or thermal imaging

camera in conjunction with moisture meters to identify high moisture areas. Thermal imaging doesn't actually measure moisture. It measures temperature, and there is a strong correlation between elevated temperatures and elevated moisture spots. Delmhorst moisture meters have saved contractors and their homeowner clients thousands of dollars and countless hours in finding the extent of and precise location of water damage.



Restoration specialists trust Delmhorst's **American made moisture meters** to give them the most accurate readings possible.

Flooring Contractors

Flooring is the foundation of every project and wood is the ideal flooring raw material. It is structurally sound, beautiful in appearance, and a pleasure to work with. Flooring manufacturers, distributors, and contractors rely on **moisture measuring instruments** to maintain both the quality of their materials and the strength, longevity and resilience of their finished work. Saw millers, dry kiln operators, furniture and cabinet makers, and even serious home do-it-yourselfers and craftsman all know that moisture content is the single most important factor affecting the quality of their wood. Years of experience, high-tech tools and controls, and premium grade lumber won't make a difference to any professional if moisture content goes unchecked.

Whether these installations are taking place on subfloors in an industrial, commercial, or residential setting, it is important that the woods, laminates, and/or adhesives being placed upon the subfloor are adequately dry. This helps prevent floor cupping, buckling, warping, shrinking, cracks and splits that are easily noticeable. A moisture meter is the reliable way to minimize defects like shrinkage, cracks, and splits. Whether your quality control program is a one-man show or a whole flooring installation department applying world class standards, a moisture meter- especially one with data analysis capabilities is essential to successful floor installs.

DIY'ers

While excessive moisture is not a significant problem in desert climates, people in coastal areas and regions that receive considerable wind driven rainfall or are living in extreme humidity need to be extra vigilant about **moisture intrusion**. After a high water or extensive driving rain event, checking wooden beams, flooring, drywall, insulation, and other components of the structure for excessive moisture levels may be done with a portable handheld device. If the presence of moisture or mold is detected, it might be a good time to call a qualified remediation and restoration specialist.



What is the Right Type of Moisture Meter for You?

At Delmhorst, our Made in America **meters** are designed to perform accurately and consistently regardless of the climate, altitude, or existing weather conditions. Because every construction project requires different features and functions, we have developed a broad range of moisture meters. Regardless of which meter you choose, you will always be able to rely on our products to return accurate results each and every time you pull them out of your toolbox.

Here is a summary of moisture meter types, measuring capabilities and their uses.

Pinless Moisture Meters

Pinless moisture [meters](#) are used for measuring moisture content within materials that you either can't physically penetrate, or would rather not because of aesthetic reasons. When a capacitance-type pinless moisture meter is placed against the surface of a material, a capacitor is formed by the meter's sensor plate and the material being measured. This capacitance depends on the dielectric properties of the material and is measured by an electromagnetic wave that penetrates the material. The meter's circuit convert's the signal to a moisture reading.

There are many advantages to using a pinless measuring device such as:

- Scan large areas quickly.
- No pin holes.
- Quickly discover water pockets.
- Average multiple measurements for more accurate results.
- Ideal for rapid home inspection.
- Measurements are available instantly.

The following diagram illustrates that pin-type meters and surface meters provide different information about the moisture content in a board. Each technology may be appropriate for different applications. Before choosing a meter, it is important to understand these differences in readings and choose the type of meter best suited for your particular application.

There are some disadvantages to pinless meters:

- Require a flat measuring surface
- Require sufficient material beneath the sensor for an accurate reading
- Chemically treated woods may affect meter readings

Pin Meters

Pin meters are the most commonly used moisture measuring devices on the market. They are a surefire way to obtain three key pieces of information quickly and accurately:

- moisture gradient (the difference between the shell and core moisture)
- an estimate of the average moisture content
- the range of moisture content

Pin-type meters operate on the principle of electrical resistance; they use the wood as an element in a circuit by driving two pins or electrodes into it.

The electrical resistance method for determining moisture content had been around for years but became fully accepted by industry in the late 1940's, when Delmhorst introduced its ram-type electrode with two insulated pins. These pins operate as electrodes; one generates an electrical current, and the other records how long that it takes for the current to travel between through the material. This is known as a resistance measurement. This method works because moisture is an excellent conductor of electricity and dry wood is an effective insulator. Pin Meters are highly accurate when used in [wood](#), gypsum, insulation, or concrete.

The most important feature of resistance type meters with insulated pins is that they measure only at the depth pins have been driven and in a line between the non-insulated portion of the pins. So the user can drive pins into the wood in as little as 1/8" increments to read the moisture content (M.C.) at different depths, leaving no question as to actual moisture content, distribution and range.

The advantages to using a pin meter include:

- Precise and accurate readings on wood, gypsum, insulation, and concrete
- Surface texture does not affect readings
- A maximum measuring depth of approximately 2", depending on length of contact pins
- Measurements are available instantly

The disadvantages of pin moisture meters include:

- They leave two small holes in the surface of the object
- Material temperature can distort readings

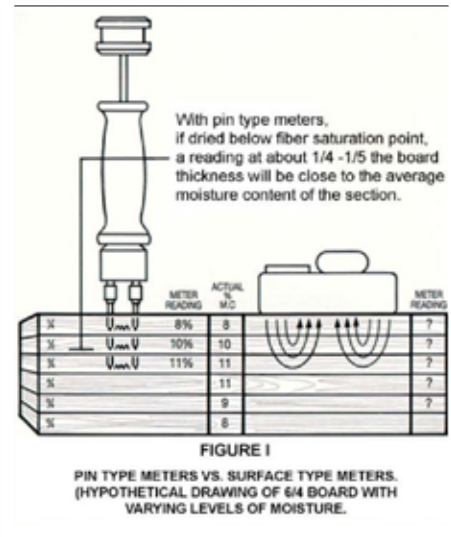

Relative Humidity (RH) Moisture Meters for Concrete

Set concrete can't be penetrated by a pin meter, and pinless moisture meters can return varying data due to rebar, concrete causticity, and subsurface composition. As a result, it is best to measure concrete with an RH meter. RH meters comply with the global measurement 'gold' standard known as ASTM F-2170-11.

Every contractor appreciates accurate, rugged and reliable tools that ensure their projects run smoothly and results in high quality work. Delmhorst's extensive product research, design and testing to conform to the new ASTM F-2170-11 standards have resulted in an outstanding, easy to use, durable RH moisture meter. The [HT-4000 meter](#) provides quantitative measurements in concrete. Its unique plug in sensor is inserted into a sleeve designed for easy adherence to the ASTM F-2170-11 Standard.

It is important to remember that the inside of a concrete slab is an inherently caustic environment. The HT-4000 sensor sleeve design assures you're not leaving your sensor in a caustic concrete environment. Anything exposed in a caustic environment for prolonged periods of time are likely to be affected and therefore results can be compromised. It's a good idea to be conscious of the surrounding conditions your sensors are in, and check to see that your readings are consistent and make sense. If not, check the meter's calibration or contact the manufacturer.



Top things to look for in an RH meter for accuracy and functionality:

- Intuitive user interface
- Ability to remove sensor from caustic concrete environment protects sensor and allows for verification of sensor calibration
- Built in battery checks

The advantages of RH meters include:

- Quantitative measurement
- Provides a long-term average of the relative humidity
- Measure moisture at depths of up to 40% of the thickness of the slab.
- Best available predictor of how slab is going to behave.

The disadvantages of RH meters include:

- ❑ Sensor that is out of calibration can provide wildly inaccurate and discrepant results
- ❑ Contamination of the reading site (boring) may lead to an inaccurate reading

Our complete [Guide for RH Sensor Behavior and Care](#) offers specifics on how to maintain optimal quality for your RH meter including:

- ❑ Explanation of Relative Humidity
- ❑ Critical Factors to be aware of when comparing relative humidity readings
- ❑ Response time of your meter
- ❑ How to Avoid rapid degradation of calibration
- ❑ Optimal operating and storage conditions
- ❑ In-field Calibration



Moisture Measurement in Concrete

Builders and **flooring contractors** sometimes rely on calcium chloride testing for monitoring the moisture content of a concrete slab. Calcium chloride testing provides a measurement in a quantitative number, however there is much debate as to whether or not it truly measures what is going on beneath the surface of the slab.

To help improve the process of improving accurate **measuring moisture within concrete**, the Association of Standards and Testing Measurements (ASTM) developed the 2170F-11 Standard. The ASTM F-2170-11 standard is a test method with some distinct advantages over calcium chloride. These changes have been designed to provide more accurate, uniform results and the ability to test for moisture further into the slab.

Concrete is permeable, and it can take upwards of 30 days for a 4-5" thick slab to cure. Once the concrete has cured for at least 30 days, testing for moisture can begin. Moisture measurements in concrete need to be taken prior to the application of adhesives, floor coverings, or other structural elements. If accurate measurements to assess the slabs' moisture content aren't properly taken, adhesives, wood floors, linoleum, tile, or spray-on resilient flooring will ultimately fail.

Therefore, it is preferable to rectify any moisture problems as soon as possible.

Whether the concrete is intended for a healthcare facility, school, warehouse, or multi-level building, ASTM F-2170-11 should be strictly adhered to in order to prevent both structural and cosmetic damage to the finished structure.

Whether your concrete is to be installed in a residential, commercial, or industrial structure, Delmhorst Instrument has designed several moisture meters with moisture sensors that will give you a high degree of accuracy in your measurements. Among them, the following two are some of Delmhorst's most popular devices and both have been used extensively in the construction of homes, office buildings, warehouses, and factories.

Total Check

[TotalCheck](#) 3-in-1 meter measures moisture by both pin and scan modes, and features a removable thermo-hygrometer attachment that measures ambient temperature and RH, and calculates dew point and GPP. High levels of ambient humidity can be warning sign at inspection jobs, and RH is also a major concern when installing a floor over a concrete sub-floor. To address this concern, the TotalCheck



was designed to conform to the ASTM F2170-11 standard to determine RH in a concrete slab, using in-situ probes.

HT-4000

Ideal for flooring installers and restoration specialists, Delmhorst's [HT-4000](#) is designed to make testing concrete and flooring materials as simple as pushing a button. It uses our highly accurate RH/T **moisture sensor** to obtain measurements that you can rely on. Furthermore, the fully detachable electronic sensor makes it easy to adhere to ASTM F2170-11 standards when measuring concrete slabs with the device.

At Delmhorst, we know that lurking beneath the seemingly solid surface of the concrete could be moisture that may one day cause **floor cupping**, cracking, and buckling if it is not properly dried. For that reason, our meters are designed and built to be the most accurate, reliable moisture meters on the market.



ASTM F2170-11 (for Concrete Slabs) At a Glance

The American Society for Testing and Materials has recently revised ASTM F-2170-11 to help minimize damage that excessive moisture can cause to floor slabs both during and after installation. Since moisture can permeate slabs and cause deterioration and de-bonding of finished flooring and coatings, it is important for construction professionals to carefully measure and monitor the moisture content in concrete throughout every stage of the construction process.

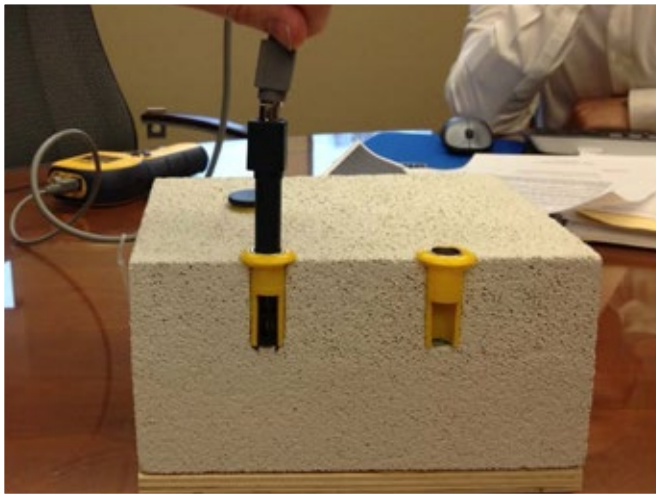
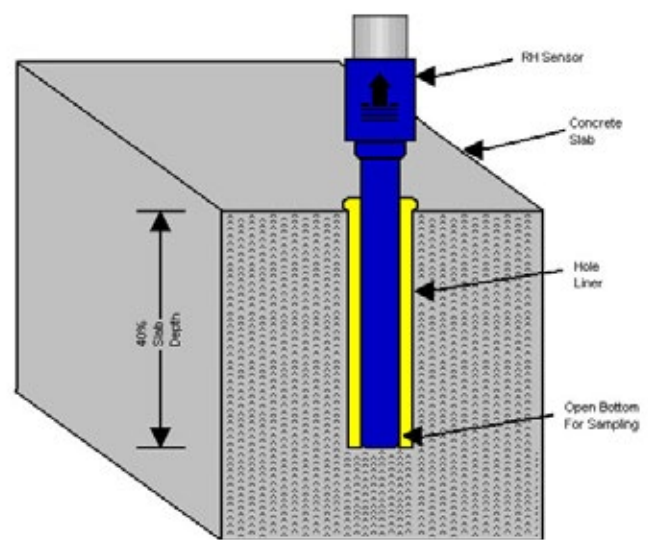

To that end, ASTM F2170-11 recommends the use of in situ probes to obtain accurate relative humidity measurements. This is a big improvement over the calcium chloride testing which is less reliable in that calcium chloride testing only indicates moisture in the top 1/8", and are prone to false positives.

The in situ method outlined by the standard relies on sensors (probes) that are placed within the slab itself. These sensors are able to detect the following:

- How much moisture remains in the slab
- Where in the slab the moisture is located
- The estimated time it will take for the moisture levels to reach equilibrium

Essentially, this standard allows for a deeper, more complete, accurate and detailed analysis than calcium chloride testing. By relying on a comprehensive set of measurements, the in situ method is a more effective and reliable form of testing. Furthermore, it is very easy to conduct and requires only a few steps to set up :

- ❑ Drill a 5/8" hole to a depth equal to 40% of the slab thickness, while making sure that the hole is smooth.
- ❑ Thoroughly vacuum debris from the hole and remove any loose concrete with a wire brush. Repeat this process as necessary until the hole is completely smooth and free of debris.
- ❑ Insert the testing sleeve into the hole while using a sealant (either silicone or water based) to insure that the hole is fully sealed.
- ❑ Cover the sleeve with a cap and allow the hole to acclimate for 72 hours.
- ❑ Once acclimated, remove the cap and insert the sensor to the full depth of the hole. Allow this sensor to rest and collect readings for a minimum of 1 hour before taking any RH and temperature readings.

Ultimately, the purpose of this testing standard is to make it much easier to determine when and how flooring installations should take place. This testing method is highly effective at reducing problems caused by excessive slab moisture content.



Moisture Measurement for Wood Flooring

Wood floors add a touch of class and elegance to homes, offices, and commercial spaces around the world. Thus, it is not surprising that property owners cherish their wood floors as valuable investments that need to be installed and maintained with an excruciating level of care.

To help achieve this, professional craftsman across America choose Delmhorst for their **moisture measuring** needs. Because the vast majority of problems with wood floors can be traced directly to excessive moisture in either the subfloor or the wood itself, flooring contractors trust our [moisture meters](#) to give them easily obtainable data that they can rely on and base their installation decisions upon. After all, skilled craftsman want their handiwork to look beautiful for generations to come, and no flooring contractor ever wants to receive a phone call notifying them that their floors are cupping, cracking, or buckling.



Given the permeability of wood, the relative humidity of its environment and other environmental factors make moisture in wood flooring an issue that **flooring contractors** pay particular attention to throughout any flooring project. Since it is best to mitigate and resolve problems before any installation takes place, our moisture meters are designed to provide accurate results that can be easily tracked and monitored. Whether you need to check the RH within the concrete subfloor and/or the moisture content within the flooring wood itself, Delmhorst has a wide variety of moisture meters for your every wood flooring moisture measurement need.

With the information provided by quality moisture meters, **flooring contractors** can take steps to prevent the following issues from occurring:

Floor Cracking: As moisture levels rise and fall throughout the year, the floor will swell and shrink accordingly. This can cause unsightly cracks to develop between the planks and allow for even greater moisture intrusion.

Floor Cupping: If a wood floor swells too much, the boards will push out around the edges of the boards. This creates an indentation running the length of the board, and if more than one board is affected, it creates a “wavy” appearance to the floor.

Floor Warping: If the concrete subfloor is improperly dried, then the wood floor on top of it can eventually pull away from as it absorbs excess moisture coming from the concrete.

Ultimately, **floor cracking, floor cupping, and floor warping** in hardwood floors installed over concrete can be avoided by adhering to the ASTM F2170-11 guidelines. This guideline is designed to help prepare a concrete subfloor and make sure that is dry enough for flooring contractors to lay that first piece of wood down.

To that end, Delmhorst’s [TotalCheck](#) meter is one of the most popular gizmos in the tool box. This 3 in 1 device allows flooring contractors to measure ambient temperature and RH, as well as calculate dew point and GPP. Effectively, the [TotalCheck](#) provides professionals with **measurements** they can rely on to ensure the longevity of their craftsmanship.

Moisture Measurement in Restoration

If you are engaged in **flood restoration** or fire restoration, you need a **moisture meter** that you can rely on. Following these disasters, measuring the **moisture content of wood** and other structural elements is critical throughout every stage of the restoration effort. Not only will excessive moisture levels cause significant structural damage, they can cause adhesives to de-bond, and facilitate the growth of mold.

For these and many other reasons, it is necessary for restoration specialists to take adequate steps to [monitor and remove moisture](#) from any water damaged structure as quickly as possible. While standing water following a disaster is easy to locate and remove, it's the water that cannot be seen that is often most concerning.



Steps to take when tackling a restoration project:

1. It's a no brainer that any standing water needs to be removed first by using water extraction equipment. If you can see it, you need to remove it before proceeding any further.
2. Once the standing water is removed, inspect the remaining structural elements. In the case of a **flood restoration** or fire restoration, common sense dictates that the structure has been saturated by water. Next, it is a good idea to reach into your tool box for both a pin and pinless meter to measure concrete subfloors, walls, and ceiling elements. [Navigator Pro](#) can be used to check moisture in drywall, insulation, wood, concrete, and plaster. It traces leaks to find exterior moisture and dry rot.
3. These easy to use devices allow **restoration** specialists to quickly and accurately measure the **moisture content of wood**, concrete, and gypsum. The measurements that are returned help identify areas where further testing might be required.
4. Finally, if any of these measurements indicate that an area has been saturated with moisture, it can be marked and tracked closely throughout the remaining stages of the restoration process.

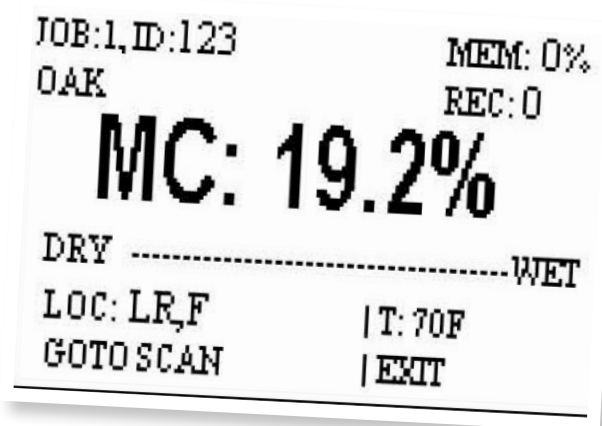

Of course, not every restoration professional is involved in post-disaster recovery. Delmhorst's **American made [moisture meters](#)** are designed to work in virtually any condition and environment needed.



Conclusion

Now that you have an understanding of how and why these moisture measurement devices are routinely used in just about every construction, renovation or restoration project that involves flooring, you may have more questions such as:

1. What about measuring moisture in [walls and ceilings](#)?
2. Is moisture a concern in wood for [furniture and cabinetry making](#)?
3. What about measuring moisture in [industrial and mill](#) applications?

The overall answer is yes. In every case, moisture content can mean the difference between perfection and disaster. We hope you put your new knowledge to good use.

As a family run business, DelmhorstInstruments has built a reputation for designing and manufacturing the highest quality moisture meters available on the market. Our commitment to unparalleled product excellence and superior service began as a mission. Now, over 65 years later it is our hallmark. Today, we serve more industries than all of our competitors combined, and are recognized as the market leader in each of those industries.

Feel free to give us a call 1 **877 DELMHORST** or email info@delmhorst.com for answers to your questions about what kind of meter to use for your project, and where to purchase. And remember, we value our customers and look forward to your feedback. For more information on these and other topics related to the industry, follow our blog at www.info.delmhorst.com.



Feel free to give us a call or email for answers to your questions about what kind of meter to use for your project, and where to purchase. And remember, we value our customers and look forward to your feedback.

CONNECT WITH US:

 <http://www.delmhorst.com>

877-335-6467

877-DELMHORST

877-335-6467

