

**25HBB3
Base 13 Heat Pump
with Puron® Refrigerant
1 – 1/2 to 5 Nominal Tons (Sizes 18 to 60)**



Turn to the Experts.™

Product Data



Carrier heat pumps with Puron® refrigerant provide a collection of features unmatched by any other family of equipment. The 25HBB has been designed utilizing Carrier's Puron refrigerant. The environmentally sound refrigerant allows consumers to make a responsible decision in the protection of the earth's ozone layer.

As an Energy Star® Partner, Carrier Corporation has determined that this product meets the Energy Star® guidelines for energy efficiency. Refer to the combination ratings in the Product Data for system combinations that meet Energy Star® guidelines.

NOTE: Ratings contained in this document are subject to change at any time. Always refer to the AHRI directory (www.ahridirectory.org) for the most up-to-date ratings information.

INDUSTRY LEADING FEATURES / BENEFITS

Efficiency

- 13 SEER/ 10.1 - 10.8 EER/ 7.7 - 8.3 HSPF (nominal)
- Microtube Technology™ refrigeration system
- Indoor air quality accessories available

Sound

- Sound level as low as 72 dBA
- Sound levels as low as 70 dBA with accessory sound blanket

Comfort

- System supports Edge® Thermidistat™ or standard thermostat controls

Reliability

- Puron® refrigerant - environmentally sound, won't deplete the ozone layer and low lifetime service cost.
- Scroll compressor
- Internal pressure relief valve
- Internal thermal overload
- High pressure switch
- Loss of charge switch
- Filter drier
- Balanced refrigeration system for maximum reliability

Durability

WeatherArmor™ protection package:

- Solid, durable sheet metal construction
- Dense wire coil guard available
- Baked-on powder paint

Applications

- Long-line - up to 250 feet (76.20 m) total equivalent length, up to 200 feet (60.96 m) condenser above evaporator, or up to 80 ft. (24.38 m) evaporator above condenser (See Longline Guide for more information.)
- Low ambient (down to -20°F/-28.9°C) with accessory kit

MODEL NUMBER NOMENCLATURE

1	2	3	4	5	6	7	8	9	10	11	12	13
N	N	A	A	A/N	N	N	N	A/N	A/N	A/N	N	N
2	5	H	B	B	3	3	6	A	0	0	3	0
Product Series	Product Family	Tier	Major Series	SEER	Cooling Capacity	Grille Variations	Open	Open	Voltage	Minor Series		
25 = HP	H = RES HP	B=Base	B = Puron	3=13 SEER		A = Dense W = Standard	0=Not Defined	0=Not Defined	3=208/230-1	0, 1, 2...		



This product has been designed and manufactured to meet Energy Star® criteria for energy efficiency when matched with appropriate coil components. However, proper refrigerant charge and proper air flow are critical to achieve rated capacity and efficiency. Installation of this product should follow all manufacturing refrigerant charging and air flow instructions. **Failure to confirm proper charge and air flow may reduce energy efficiency and shorten equipment life.**

25HBB3

STANDARD FEATURES

Feature	18	24	30	36	42	48	60
Puron Refrigerant	X	X	X	X	X	X	X
Maximum SEER Rating	14	14	14	14.5	14	14	13.5
Scroll Compressor	X	X	X	X	X	X	X
Field Installed Filter Drier	X	X	X	X	X	X	X
Front Seating Service Valves	X	X	X	X	X	X	X
Internal Pressure Relief Valve	X	X	X	X	X	X	X
Internal Thermal Overload	X	X	X	X	X	X	X
Long Line capability	X	X	X	X	X	X	X
Low Ambient capability with Kit	X	X	X	X	X	X	X
Suction Line Accumulator	X	X	X	X	X	X	X
High Pressure Switch	X	X	X	X	X	X	X
Loss of Charge Switch	X	X	X	X	X	X	X

X = Standard

PHYSICAL DATA

UNIT SIZE SERIES	18-30	24-30	30-30	36-30	42-30	48-30	60-30
Operating Weight lb (kg)	148 (67.13)	162 (73.48)	186 (84.37)	172 (78.02)	246 (111.58)	240 (108.86)	250 (113.40)
Shipping Weight lb (kg)	174 (78.93)	189 (85.73)	215 (97.52)	207 (93.89)	278 (126.10)	274 (124.28)	282 (127.91)
Compressor Type	Scroll						
REFRIGERANT	Puron® (R-410A)						
Control	TXV (Puron Hard Shutoff)						
Charge lb (kg)	4.89 (2.22)	5.50 (2.49)	7.45 (3.38)	6.49 (2.94)	8.40 (3.81)	11.40 (5.17)	11.00 (4.99)
Outdoor Heating Piston #	42	46	55	57	61	63	76
COND FAN	Propeller Type, Direct Drive						
Air Discharge	Vertical						
Air Qty (CFM)	2196	2614	2614	3472	3810	4046	4046
Motor HP	1/10	1/10	1/10	1/8	1/5	1/4	1/4
Motor RPM	1100	1100	1100	800	800	800	800
COND COIL							
Face Area (Sq ft)	14.77	15.09	21.56	17.60	25.15	17.60	17.60
Fins per In.	25	20	20	20	20	20	20
Rows	1	1	1	1	1	2	2
Circuits	4	5	5	6	6	8	8
VALVE CONNECT. (In.) ID							
Vapor	5/8	5/8	3/4	3/4	7/8	7/8	7/8
Liquid	3/8						
REFRIGERANT TUBES* (In.) OD							
Rated Vapor*	5/8	5/8	3/4	3/4	7/8	7/8	1-1/8
Liquid	3/8"						

*Units are rated with 25 ft (7.6 m) of lineset length. See Vapor Line Sizing and Cooling Capacity Loss table when using other sizes and lengths of lineset.

Note: See unit Installation Instruction for proper installation.

25HBB3

VAPOR LINE SIZING AND COOLING CAPACITY LOSS

Acceptable vapor line diameters provide adequate oil return to the compressor while avoiding excessive capacity loss. The suction line diameters shown in the chart below are acceptable for HP systems with Puron refrigerant:

Vapor Line Sizing and Cooling Capacity Losses - Puron® Refrigerant 1- Stage Heat Pump Applications

Unit Nominal Size (Btuh)	Maximum Liquid Line Diameters (In. OD)	Vapor Line Diameters (In.) OD	Cooling Capacity Loss (%) Total Equivalent Line Length ft. (m)								
			Standard Application		Long Line Application Requires Accessories						
			26-50 (7.9-15.2)	51-80 (15.5-24.4)	81-100 (24.7-30.5)	101-125 (30.8-38.1)	126-150 (38.4-45.7)	151-175 (46.0-50.3)	176-200 (53.6-60.0)	201-225 (61.3-68.6)	226-250 (68.9-76.2)
18,000 1-Stage HP with Puron	3/8	1/2	1	2	3	4	6	7	8	9	10
		5/8	0	0	1	1	1	2	2	3	3
24,000 1-Stage HP with Puron	3/8	5/8	0	1	1	2	3	3	4	4	5
		3/4	0	0	0	0	1	1	1	1	1
30,000 1-Stage HP with Puron	3/8	5/8	1	2	3	3	4	5	6	7	8
		3/4	0	0	1	1	1	2	2	2	3
		7/8	0	0	0	0	1	1	1	1	1
36,000 1-Stage HP with Puron	3/8	5/8	1	2	4	5	6	7	9	10	11
		3/4	0	0	1	1	2	2	3	3	4
		7/8	0	0	0	0	1	1	1	1	2
42,000 1-Stage HP with Puron	3/8	3/4	0	1	2	2	3	4	4	5	6
		7/8	0	0	1	1	1	2	2	2	3
48,000 1-Stage HP with Puron	3/8	3/4	0	1	2	3	4	5	5	6	7
		7/8	0	0	1	1	2	2	2	3	3
60,000 1-Stage HP with Puron	3/8	3/4	1	2	4	5	6	7	9	10	11
		7/8	0	1	2	2	3	4	4	5	5
		1-1/8	0	0	0	1	1	1	1	1	1

Standard Length = 80 ft. (24.4 m) or less total equivalent length

Applications in this area are long line. Accessories are required as shown recommended on Long Line Application Guidelines

Applications in this area may have height restrictions that limit allowable total equivalent length, when outdoor unit is below indoor unit. See Long Line Application Guidelines

REFRIGERANT PIPING LENGTH LIMITATIONS

Maximum Line Lengths:

The maximum allowable total equivalent length for heat pumps varies depending on the vertical separation. See the tables below for allowable lengths depending on whether the outdoor unit is on the same level, above or below the indoor unit.

Maximum Line Lengths for Heat Pump Applications

	MAXIMUM ACTUAL LENGTH ft (m)	MAXIMUM EQUIVALENT LENGTH† ft (m)	MAXIMUM VERTICAL SEPARATION ft (m)
Units on equal level	200 (61)	250 (76.2)	N/A
Outdoor unit ABOVE indoor unit	200 (61)	250 (76.2)	200 (61)
Outdoor unit BELOW indoor unit	See Table 'Maximum Total Equivalent Length: Outdoor Unit BELOW Indoor Unit'		

† Total equivalent length accounts for losses due to elbows or fitting. See the Long Line Guideline for details.

Maximum Total Equivalent Length† - Outdoor Unit BELOW Indoor Unit

Size	Liquid Line Diameter w/ TXV	HP with Puron® Refrigerant – Maximum Total Equivalent Length† Vertical Separation ft (m) Outdoor unit BELOW indoor unit;						
		0–20 (0 – 6.1)	21–30 (6.4 – 9.1)	31–40 (9.4 – 12.2)	41–50 (12.5 – 15.2)	51–60 (15.5 – 18.3)	61–70 (18.6 – 21.3)	71–80 (21.6 – 24.4)
18000 HP with Puron	3/8	250*	250*	250*	250*	250*	250*	250*
24000 HP with Puron	3/8	250*	250*	250*	250*	250*	250*	250*
30000 HP with Puron	3/8	250*	250*	250*	250*	250*	250*	250*
36000 HP with Puron	3/8	250*	250*	250*	250*	250*	250*	250*
42000 HP with Puron	3/8	250*	250*	250*	250*	250*	250*	150
48000 HP with Puron	3/8	250*	250*	250*	250*	230	160	--
60000 HP with Puron	3/8	250*	225*	190	150	110	--	--

* Maximum actual length not to exceed 200 ft (61 m)

† Total equivalent length accounts for losses due to elbows or fitting. See the Long Line Guideline for details.

-- = outside acceptable range

LONG LINE APPLICATIONS

An application is considered Long Line when the refrigerant level in the system requires the use of accessories to maintain acceptable refrigerant management for systems reliability. Defining a system as long line depends on the liquid line diameter, actual length of the tubing, and vertical separation between the indoor and outdoor units.

For Heat Pump systems, the chart below shows when an application is considered Long Line. Beyond these lengths, long line accessories are required:

HP WITH PURON® REFRIGERANT LONG LINE DESCRIPTION ft (m) Beyond these lengths, long line accessories are required

Liquid Line Size	Units On Same Level	Outdoor Below Indoor	Outdoor Above Indoor
3/8	80 (24.4)	20 (6.1) vertical or 80 (24.4) total	80 (24.4)

Note: See Long Line Guideline for details

ACCESSORIES

ORDER NUMBER	DESCRIPTION	18-30	24-30	30-30	36-30	42-30	48-30	60-30
HC34GE240	BALL BEARING MOTOR	X	X	X				
HC36GE232	BALL BEARING MOTOR				X			
HC38GE228	BALL BEARING MOTOR					X		
HC40GE228	BALL BEARING MOTOR						X	X
KAACH1701AAA	CRANKCASE HTR	X	X	X	X			
KAACH1601AAA	CRANKCASE HTR					X		
STANDARD	CRANKCASE HTR						S	S
KSACY0101AAA	CYCLE PROTECTOR	X	X	X	X	X	X	X
KAAFT0101AAA	FREEZE THERMOSTAT	X	X	X	X	X	X	X
KSAHS1701AAA	HARD START	X	X	X	X	X	X	X
KHAIR0101AAA	ISOLATION RELAY	X	X	X	X	X	X	X
KSALA0301410	LOW AMBIENT PSW	X	X	X	X	X	X	X
KSALA0601AAA†	MOTORMASTER 230V	X	X	X	X	X	X	X
KHAOT0201SEC	OUTDOOR THERMOSTAT	X	X	X	X	X	X	X
KHAOT0301FST	OUTDOOR THERMOSTAT	X	X	X	X	X	X	X
KHALS0401LLS	SOLENOID VALVE	X	X	X	X	X	X	X
KHASS0606MPK*	SNOW STAND RACK		X	X	X	X	X	X
KSASH0601COP	SOUND BLKT	X	X	X	X	X	X	
KSASH2101COP	SOUND BLKT							X
KAACS0201PTC	START ASSIST PTC	X	X	X	X	X	X	X
KSASF0101AAA	SUPPORT FEET	X	X	X	X	X	X	X
KAATD0101TDR	TIME DELAY RELAY	X	X	X	X	X	X	X
KSATX0201PUR	TXV PURON HSO	X	X	X				
KSATX0301PUR	TXV PURON HSO				X	X		
KSATX0401PUR	TXV PURON HSO						X	
KSATX0501PUR	TXV PURON HSO							X

x = Accessory S = Standard

* Available through RCD

† Required accessories include ball bearing fan motor, compressor start assist (CAP / Relay), crankcase heater, evaporator freeze stat, isolation relay, hard shut-off TXV or liquid line solenoid valve.

25HBB3

ACCESSORY THERMOSTATS

THERMOSTAT / SUBBASE PKG.	DESCRIPTION
TP-PRH01-A	Programmable Thermidistat
TP-NRH01-A	Non-programmable Thermidistat
TP-PHP01	Performance Series Programmable HP Stat
TP-NHP01	Performance Series Non-programmable HP Stat
TC-PHP01	Comfort Series Programmable HP Stat
TC-NHP01	Comfort Series Non-programmable HP Stat
TB-PHP01	Base Series Programmable HP Stat
TB-NHP01	Base Series Non-programmable HP Stat
TSTATXXSEN01-B*	Outdoor Air Temperature Sensor
TSTATXXNBP01	Backplate for Non-Programmable Thermostat
TSTATXXBP01	Backplate for Programmable Thermostat and Thermidistat™ Control
TSTATXXSBP01	Backplate for Standard Programmable Thermostat
TSTATXXBBP01	Backplate for Builder's Thermostat
TSTATXXCNV10†	Thermostat Conversion Kit (4 to 5 Wire) — 10 Pack

* Outdoor temperature sensor is an accessory for all Carrier electronic thermostats, except the non-programmable air conditioner version and builders thermostats. It allows the temperature at a remote location (outdoors) to be displayed on the thermostat. The outdoor air temperature sensor must be used with the HybridHeat™ (dual fuel) thermostat.

† Thermostat conversion kit is a 24-vac accessory that can turn a 4-wire thermostat application into a 5-wire application. This kit can also be used to replace a broken thermostat wire, or add an extra wire when needed.

The outdoor air temperature sensor is included with the Thermidistat Control and HybridHeat™ (dual fuel) thermostat.

ACCESSORY USAGE GUIDELINE

Accessory	REQUIRED FOR LOW-AMBIENT COOLING APPLICATIONS (Below 55°F / 12.8°C)	REQUIRED FOR LONG LINE APPLICATIONS* (Over 80 ft. / 24.38 m)	REQUIRED FOR SEA COAST APPLICATIONS (Within 2 miles / 3.22 km)
Accumulator	Standard	Standard	Standard
Ball Bearing Fan Motor	Yes†	No	No
Compressor Start Assist Capacitor and Relay	Yes	Yes	No
Crankcase Heater	Yes	Yes	No
Evaporator Freeze Thermostat	Yes	No	No
Hard Shutoff TXV	Yes	Yes	Yes
Isolation Relay	Yes	No	No
Liquid Line Solenoid Valve	No	See Long-Line Application Guideline	No
Motor Master® Control or Low Ambient Switch	Yes	No	No
Support Feet	Recommended	No	Recommended

* For tubing line sets between 80 and 200 ft. (24.38 and 60.96 m) and/or 20 ft. (6.09 m) vertical differential, refer to Residential Split-System Longline Application Guideline.

† Additional requirement for Low-Ambient Controller (full modulation feature) MotorMaster® Control.

Accessory Description and Usage (Listed Alphabetically)

1. Ball-Bearing Fan Motor

A fan motor with ball bearings which permits speed reduction while maintaining bearing lubrication.

Usage Guideline:

Required on all units when using MotorMaster®

2. Compressor Start Assist - Capacitor and Relay

Start capacitor and relay gives a "hard" boost to compressor motor at each start up.

Usage Guideline:

Required for reciprocating compressors in the following applications:

- Long line
- Low ambient cooling
- Hard shut off expansion valve on indoor coil
- Liquid line solenoid on indoor coil

Required for single-phase scroll compressors in the following applications:

- Long line
- Low ambient cooling

Suggested for all compressors in areas with a history of low voltage problems.

3. Compressor Start Assist — PTC Type

Solid state electrical device which gives a "soft" boost to the compressor at each start-up.

Usage Guideline:

Suggested in installations with marginal power supply.

4. Crankcase Heater

An electric resistance heater which mounts to the base of the compressor to keep the lubricant warm during off cycles. Improves compressor lubrication on restart and minimizes the chance of liquid slugging.

Usage Guideline:

- Required in low ambient cooling applications.
- Required in long line applications.
- Suggested in all commercial applications.

5. Evaporator Freeze Thermostat

An SPST temperature-actuated switch that stops unit operation when evaporator reaches freeze-up conditions.

Usage Guideline:

Required when low ambient kit has been added.

6. Isolation Relay

An SPDT relay which switches the low-ambient controller out of the outdoor fan motor circuit when the heat pump switches to heating mode.

Usage Guideline:

Required in all heat pumps where low ambient kit has been added.

7. Liquid-Line Solenoid Valve (LLS)

An electrically operated shutoff valve which stops and starts refrigerant liquid flow in response to compressor operation. It is to be installed at the outdoor unit to control refrigerant off cycle migration in the heating mode.

Usage Guideline:

An LLS is required in all long line heat pump applications to control refrigerant off cycle migration in the heating mode. See Long Line Guideline.

8. Low-Ambient Pressure Switch Kit

A long life pressure switch which is mounted to outdoor unit service valve. It is designed to cycle the outdoor fan motor in order to maintain head pressure within normal operating limits. The control will maintain working head pressure at low-ambient temperatures down to 0°F (-18°C) when properly installed.

Usage Guideline:

A Low-Ambient Pressure Switch or MotorMaster® Low-Ambient Controller must be used when cooling operation is used at outdoor temperatures below 55°F (12.8°C).

9. MotorMaster® Low-Ambient Controller

A fan-speed control device activated by a temperature sensor, designed to control condenser fan motor speed in response to the saturated, condensing temperature during operation in cooling mode only. For outdoor temperatures down to -20°F (-28.9°C), it maintains condensing temperature at 100°F ±10°F (37.8°C ± 6.5°C).

Usage Guideline:

A MotorMaster® Low Ambient Controller or Low-Ambient Pressure Switch must be used when cooling operation is used at outdoor temperatures below 55°F (12.8°C).

Suggested for all commercial applications.

Accessory Description and Usage (Listed Alphabetically) - CONTINUED

10. Outdoor Air Temperature Sensor

Designed for use with Carrier Thermostats listed in this publication. This device enables the thermostat to display the outdoor temperature. This device also is required to enable special thermostat features such as auxiliary heat lock out.

Usage Guideline:

Suggested for all Carrier thermostats listed in this publication.

11. Outdoor Thermostat

An SPDT temperature-actuated switch which turns on supplemental electric heaters when outdoor air temperature drops below a user-selected set point.

Usage Guideline:

Electric supplemental heat applications in non-variable speed indoor units when electric heat staging is desired.

12. Secondary Outdoor Thermostat

An SPDT temperature-actuated switch which turns on third-stage of supplemental electric heaters when outdoor air temperature drops below the second-stage set point.

Usage Guideline:

Outdoor thermostat applications where electric heater is capable of 3-stage operation.

13. Snow Stand Rack

Coated wire rack which supports unit 18 in. (457.2 mm) above mounting pad to allow for drainage from unit base.

Usage Guideline:

Suggested in the following applications:

Heat pump installations in heavy snowfall areas.

Heat pump installations in snow drift locations.

Heat pump installations in areas of prolonged subfreezing temperatures.

All commercial installations.

14. Sound Hood

Wraparound sound reducing cover for the compressor. Reduces the sound level by about 2 dBA.

Usage Guideline:

Suggested when unit is installed closer than 15 ft. (4.577 m) to quiet areas, bedrooms, etc.

Suggested when unit is installed between two houses less than 10 ft. (3.05 m) apart.

15. Thermostatic Expansion Valve (TXV) Bi-Flow

A modulating flow-control valve which meters refrigerant liquid flow rate into the evaporator in response to the superheat of the refrigerant gas leaving the evaporator.

Usage Guideline:

Accessory required to meet ARI rating and system reliability, where indoor not equipped.

Required in all heat pump applications designed with Puron refrigerant.

16. Time-Delay Relay

An SPST delay relay which briefly continues operation of indoor blower motor to provide additional cooling after the compressor cycles off.

Note: Most indoor unit controls include this feature. For those that do not, use the guideline below.

Usage Guideline:

Accessory required to meet ARI rating, where indoor not equipped.

ELECTRICAL DATA

UNIT SIZE	V/PH	OPER VOLTS*		COMPR		FAN	MCA	MIN WIRE SIZE†	MIN WIRE SIZE†	MAX LENGTH ft (m)‡	MAX LENGTH ft (m)‡	MAX FUSE** or CKT BRK AMPS
		MAX	MIN	LRA	RLA	FLA		60° C	75° C	60° C	75° C	
18-30	208/230/1	253	197	48.0	9.0	0.77	12.0	14	14	66 (20.1)	62 (18.9)	20
24-30				58.3	12.8	0.75	16.8	14	14	47 (14.3)	45 (13.7)	25
30-30				77.0	16.0	0.8	20.8	12	12	58 (17.7)	56 (17.1)	30
36-30				79.0	16.7	0.9	21.7	12	12	58 (17.7)	55 (16.8)	35
42-30				109.0	19.9	1.2	26.0	10	10	77 (23.5)	73 (22.3)	40
48-30				117.0	21.8	1.2	28.4	8	8	109 (33.2)	104 (31.7)	50
60-30				134.0	26.3	1.2	34.1	8	8	91 (27.7)	87 (26.5)	50

* Permissible limits of the voltage range at which the unit will operate satisfactorily

† If wire is applied at ambient greater than 30°C, consult table 310-16 of the NEC (NFPA 70). The ampacity of non-metallic-sheathed cable (NM), trade name ROMEX, shall be that of 60°C conditions, per the NEC (NFPA 70) Article 336-26. If other than uncoated (no-plated), 60 or 75°C insulation, copper wire (solid wire for 10 AWG or smaller, stranded wire for larger than 10 AWG) is used, consult applicable tables of the NEC (NFPA 70).

‡ Length shown is as measured 1 way along wire path between unit and service panel for voltage drop not to exceed 2%.

** Time-Delay fuse.

FLA - Full Load Amps

LRA - Locked Rotor Amps

MCA - Minimum Circuit Amps

RLA - Rated Load Amps

NOTE: Control circuit is 24-V on all units and requires external power source. Copper wire must be used from service disconnect to unit.

All motors/compressors contain internal overload protection.

Complies with 2007 requirements of ASHRAE Standards 90.1

25HBB3

A-WEIGHTED SOUND POWER

UNIT SIZE	STANDARD RATING (dBA)	TYPICAL OCTAVE BAND SPECTRUM (dBA, without tone adjustment)						
		125	250	500	1000	2000	4000	8000
18-30	74	52.0	63.5	68.0	70.5	66.5	62.0	57.5
24-30	75	54.5	64.0	69.0	69.5	67.5	64.0	58.0
30-30	74	52.0	62.5	66.5	68.5	65.0	63.5	59.0
36-30	72	55.0	62.0	63.5	66.0	64.0	61.5	54.0
42-30	77	55.5	60.0	63.5	71.5	65.0	62.5	59.0
48-30	77	58.0	65.5	68.5	72.0	66.5	60.5	53.0
60-30	77	55.0	63.0	67.5	71.5	68.0	64.0	60.5

NOTE: Tested in accordance with ARI Standard 270-08 (not listed in ARI).

A-WEIGHTED SOUND POWER WITH SOUND HOOD

UNIT SIZE	STANDARD RATING (dBA)	TYPICAL OCTAVE BAND SPECTRUM (dBA, without tone adjustment)						
		125	250	500	1000	2000	4000	8000
18-30	73	52.5	63.0	67.5	69.0	66.0	62.0	55.5
24-30	74	54.0	63.5	69.0	69.0	67.5	63.5	57.5
30-30	74	51.5	62.0	66.5	67.5	64.5	62.0	57.5
36-30	70	54.5	62.0	63.5	64.5	63.0	60.0	51.5
42-30	75	55.0	60.5	63.5	69.0	64.5	61.5	56.0
48-30	74	58.0	64.5	69.0	68.5	66.0	60.0	53.0
60-30	74	55.0	63.5	67.0	69.0	66.5	62.0	57.0

NOTE: Tested in accordance with ARI Standard 270-08 (not listed in ARI).

CHARGING SUBCOOLING (TXV-TYPE EXPANSION DEVICE)

UNIT SIZE-SERIES	REQUIRED SUBCOOLING °F (°C)
18-30	10 (5.6)
24-30	12 (6.7)
30-30	12 (6.7)
36-30	9 (5.0)
42-30	11 (6.1)
48-30	11 (6.1)
60-30	12 (6.7)

DIMENSIONS - ENGLISH

UNIT	SERIES	ELECTRICAL CHARACTERISTICS		A	B	C	D	E	F	G	K	L	M	N	P	OPERATING WEIGHT (lbs)	SHIPPING WEIGHT (lbs)	SHIPPING DIMENSIONS (L x W x H)
25HBB318	0	X	0	0	25 3/4"	3 3/4"	3 3/4"	5/8"	4 7/16"	21 1/4"	9 1/8"	2 13/16"	13 1/2"	14 1/2"	14"	148	174	26 7/8" x 30 1/16" x 39 3/8"
25HBB324	0	X	0	0	31 3/16"	3 3/4"	3 3/4"	5/8"	6 9/16"	24 11/16"	9 1/8"	1 1/2"	15 5/8"	16 3/4"	14 1/2"	162	189	32 3/8" x 35 1/2" x 32 9/16"
25HBB330	0	X	0	0	31 3/16"	3 3/4"	3 3/4"	3/4"	6 9/16"	24 11/16"	9 1/8"	1 1/2"	16 1/2"	15 1/2"	17"	186	215	32 3/8" x 35 1/2" x 42 3/4"
25HBB336	0	X	0	0	35"	3 3/4"	3 3/4"	3/4"	6 9/16"	28 7/16"	9 1/8"	1 1/2"	15 1/2"	15 3/4"	12 1/2"	207	246	36 1/8" x 39 5/16" x 32 9/16"
25HBB342	0	X	0	0	35"	3 3/4"	3 3/4"	7/8"	6 9/16"	28 7/16"	9 1/8"	5/8"	17 1/4"	19 1/8"	15 3/4"	246	278	36 1/8" x 39 5/16" x 42 3/4"
25HBB348	0	X	0	0	35"	3 3/4"	3 3/4"	7/8"	6 9/16"	28 7/16"	9 1/8"	5/8"	17"	16"	12"	240	273	36 1/8" x 39 5/16" x 32 9/16"
25HBB360	0, 1	X	0	0	35"	3 3/4"	3 3/4"	7/8"	6 9/16"	28 7/16"	9 1/8"	5/8"	17"	16"	12"	250	282	36 1/8" x 39 5/16" x 32 9/16"

X = YES
0 = NO

- NOTES:**
1. ALLOW 24" CLEARANCE TO SERVICE END OF UNIT. 48" ABOVE UNIT. 6" ON ONE SIDE, 12" ON REMAINING SIDE, AND 24" BETWEEN UNITS FOR PROPER AIRFLOW.
 2. MINIMUM OUTDOOR OPERATING AMBIENT IN COOLING MODE IS 55°F, 125°F MAX.
 3. SERIES DESIGNATION IS THE 13TH POSITION OF THE UNIT MODEL NUMBER.
 4. CENTER OF GRAVITY 
 5. ALL DIMENSIONS ARE IN "INCHES" UNLESS OTHERWISE NOTED.

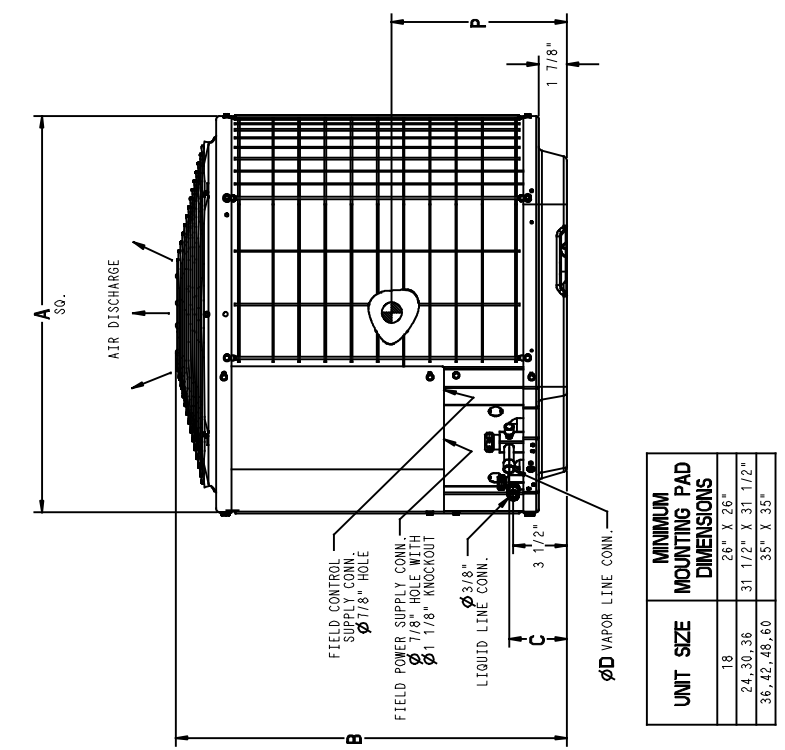
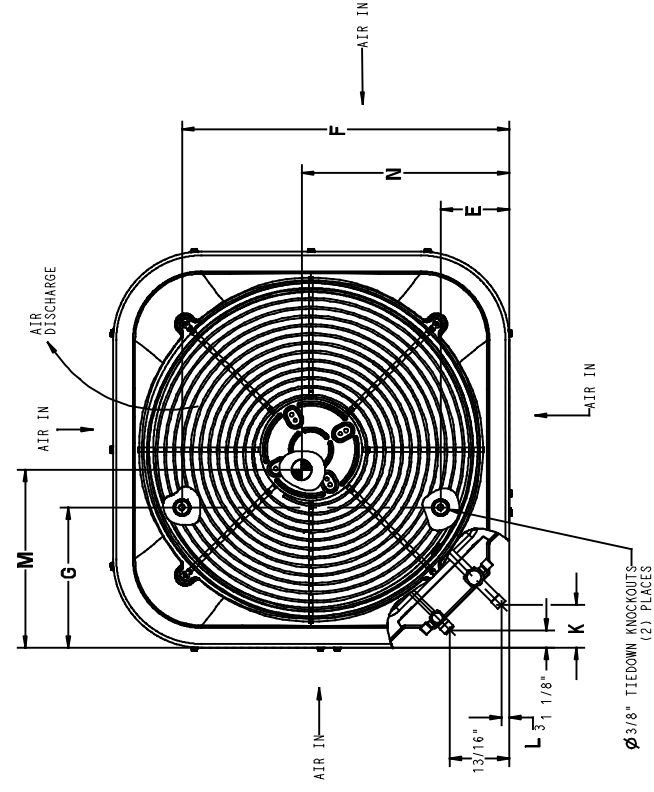

UNIT SIZE	MINIMUM MOUNTING PAD DIMENSIONS
18	26" X 26"
24, 30, 36	31 1/2" X 31 1/2"
36, 42, 48, 60	35" X 35"

25HBB3

25HBB3

DIMENSIONS - SI

UNIT	SERIES	ELECTRICAL CHARACTERISTICS		A	B	C	D	E	F	G	K	L	M	N	P	OPERATING WEIGHT (Kgs)	SHIPPING WEIGHT (Kgs)	SHIPPING DIMENSIONS (L x W x H)
25HBB318	0	X	0	0	654.0	895.4	95.2	15.9	112.7	539.8	231.8	71.4	342.9	368.3	355.6	67.1	78.9	682.6 X 763.6 X 1000.1
25HBB324	0	X	0	0	792.2	735.0	95.2	15.9	166.7	627.1	231.8	71.4	396.9	425.4	388.3	73.5	85.7	822.3 X 901.7 X 827.1
25HBB330	0	X	0	0	792.2	993.8	95.2	19.0	166.7	627.1	231.8	71.4	419.1	393.7	431.8	84.4	97.5	822.3 X 901.7 X 1085.8
25HBB336	0	X	0	0	889.0	735.0	95.2	19.0	166.7	722.3	231.8	71.4	393.7	400.0	371.5	78.0	93.9	917.6 X 998.6 X 827.1
25HBB342	0	X	0	0	889.0	993.8	98.4	22.2	166.7	722.3	231.8	74.6	438.2	485.8	400.0	111.6	126.1	917.6 X 998.6 X 1085.8
25HBB348	0	X	0	0	889.0	735.0	98.4	22.2	166.7	722.3	231.8	74.6	431.8	406.4	304.8	108.9	123.8	917.6 X 998.6 X 827.1
25HBB360	0, 1	X	0	0	889.0	735.0	98.4	22.2	166.7	722.3	231.8	74.6	431.8	406.4	304.8	113.4	127.9	917.6 X 998.6 X 827.1

X = YES
0 = NO

208-230-160	230-160	460-3-60
208/230-3-60		

NOTES:

1. ALLOW 609.6 CLEARANCE TO SERVICE END OF UNIT. 1219.2 ABOVE UNIT. 152.4 ON ONE SIDE. 304.8 ON REMAINING SIDE. AND 609.6 BETWEEN UNITS FOR PROPER AIRFLOW.
2. MINIMUM OUTDOOR OPERATING AMBIENT IN COOLING MODE IS 12.8°C. 51.7°C MAX.
3. SERIES DESIGNATION IS THE 13TH POSITION OF THE UNIT MODEL NUMBER.
4. CENTER OF GRAVITY
5. ALL DIMENSIONS ARE IN "MM" UNLESS OTHERWISE NOTED.

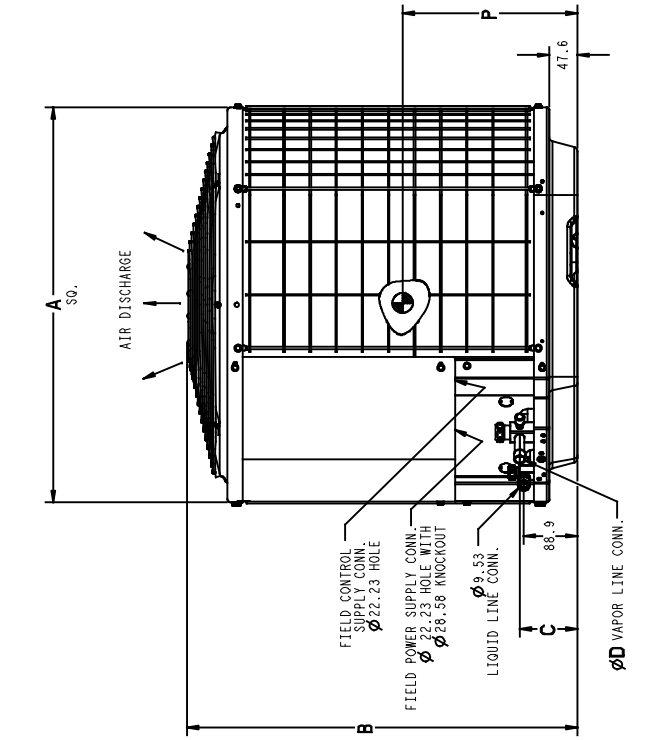
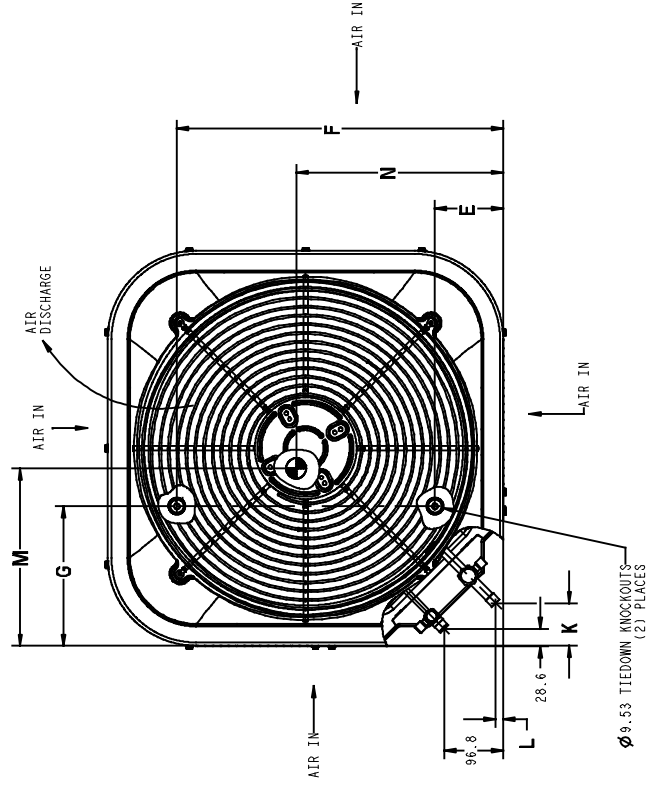

UNIT SIZE	MINIMUM MOUNTING PAD DIMENSIONS
18	660.4 X 660.4
24, 30, 36	800.1 X 800.1
36, 42, 48, 60	889.0 X 889.0

25HBB3 BALANCE POINT WORKSHEET

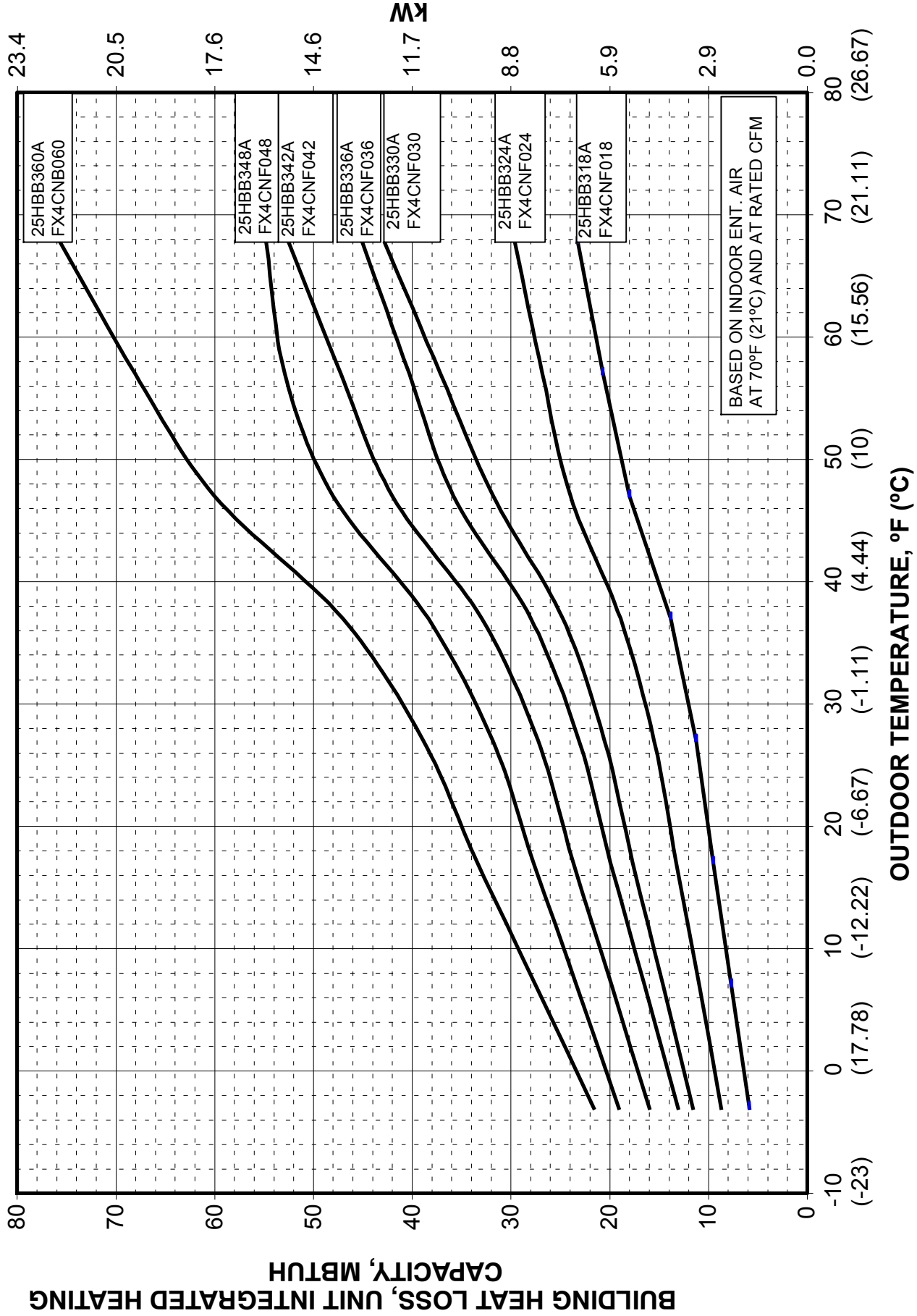

CLEARANCES

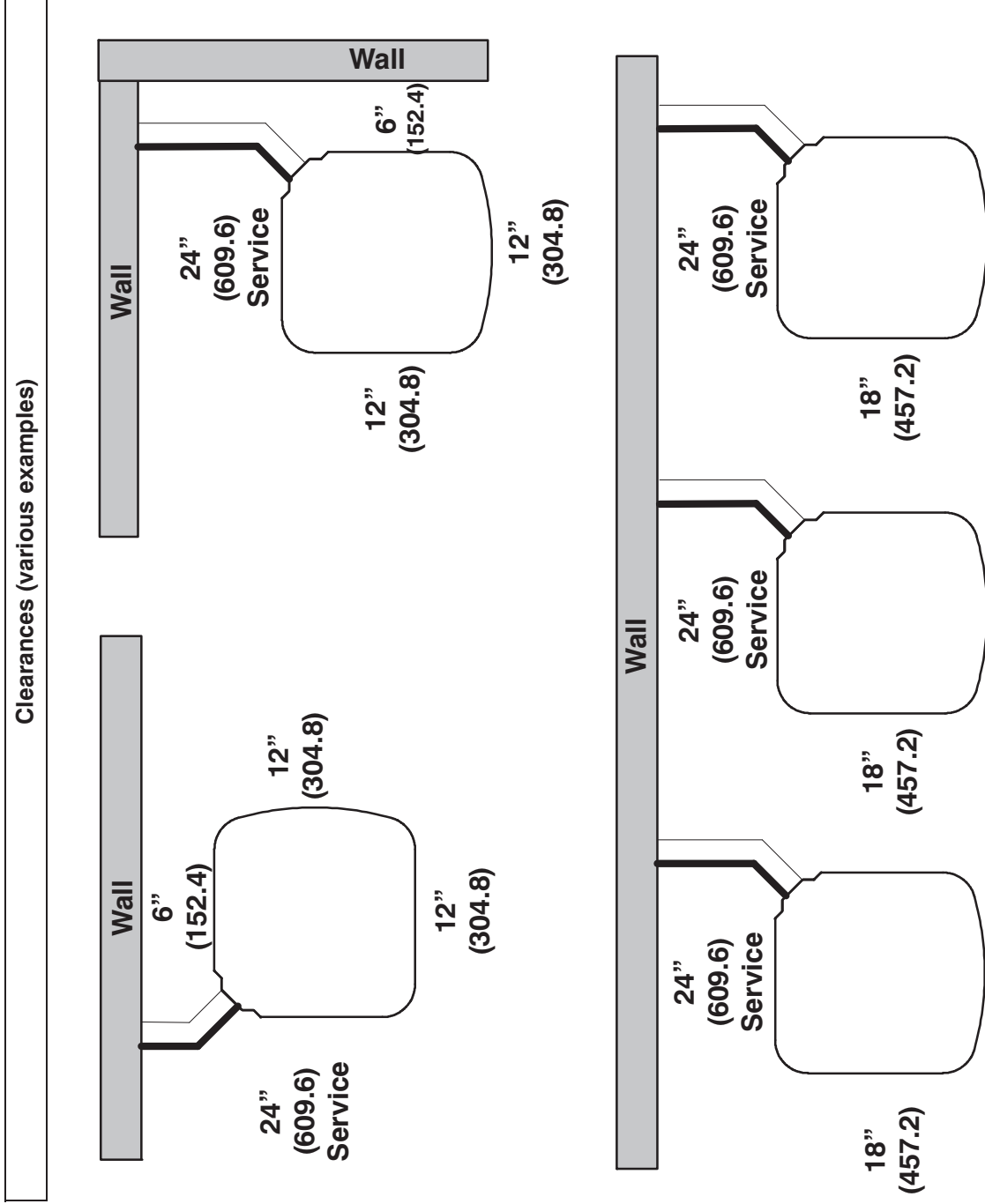

Note: Numbers in () = mm

IMPORTANT: When installing multiple units in an alcove, roof well, or partially enclosed area, ensure there is adequate ventilation to prevent re-circulation of discharge air.

COMBINATION RATINGS CONTINUED

ARI Ref. No.	Model Number	Coil Model Number	Furnace Model Number	Cooling Capacity	EER	SEER	High Temp		HSPF	Low Temp	
							E Capacity	E COP		H Capacity	H COP
3253529	25HBB348(A,W)30	CSPH*6012A**	58CV(A,X)110-20	47,500	12.0	14.00	47,500	3.72	8.2	29,200	2.64
3253530	25HBB348(A,W)30	CSPH*6012A**	58CV(A,X)135-22	48,000	12.0	14.00	47,000	3.74	8.2	29,000	2.66
3253531	25HBB348(A,W)30	CSPH*6012A**	58CV(A,X)155-22	48,000	12.0	14.00	47,000	3.76	8.2	29,000	2.68
3253466	25HBB348(A,W)30	CSPH*6012A**	58MEB080-16	48,000	12.0	14.00	47,500	3.72	8.1	29,600	2.64
3253467	25HBB348(A,W)30	CSPH*6012A**	58MEB100-20	48,000	12.5	14.50	47,000	3.76	8.2	29,200	2.68
3253468	25HBB348(A,W)30	CSPH*6012A**	58MEB120-20	48,500	12.5	14.50	47,000	3.78	8.2	29,200	2.68
3253525	25HBB348(A,W)30	CSPH*6012A**	58MV(B,C)080-20	47,500	12.0	14.00	47,500	3.66	8.0	29,400	2.62
3253526	25HBB348(A,W)30	CSPH*6012A**	58MV(B,C)100-20	47,500	12.0	14.00	47,500	3.68	8.0	29,200	2.62
3253527	25HBB348(A,W)30	CSPH*6012A**	58MV(B,C)120-20	47,500	12.0	14.00	47,500	3.68	8.0	29,200	2.62
3253443	25HBB348(A,W)30	CSPH*6012A**	58PH*090-16	48,000	12.0	14.50	47,500	3.74	8.2	29,400	2.66
3253444	25HBB348(A,W)30	CSPH*6012A**	58PH*110-20	48,000	12.0	14.75	47,000	3.76	8.2	29,200	2.68
3253445	25HBB348(A,W)30	CSPH*6012A**	58PH*135-20	48,000	12.0	14.50	47,500	3.76	8.2	29,200	2.66
3253524	25HBB348(A,W)30	CSPH*6012A**+TDR		48,000	11.5	13.50	48,000	3.68	8.2	30,200	2.62
3253537	25HBB360(A,W)30	†FY4ANB060		58,500	10.8	13.00	58,000	3.52	7.7	37,000	2.50
3253580	25HBB360(A,W)30	FE4ANB006+UI		59,500	11.2	13.50	57,000	3.68	8.0	36,000	2.60
3253581	25HBB360(A,W)30	FV4BNB006		59,500	11.5	14.00	57,000	3.68	8.0	36,000	2.60
3253548	25HBB360(A,W)30	FX4CN(B,F)060		59,000	11.2	13.50	57,500	3.66	7.7	36,200	2.58
3253560	25HBB360(A,W)30	CAP**6021A**	58CV(A,X)110-20	58,000	11.0	13.20	57,500	3.52	7.7	36,400	2.52
3253549	25HBB360(A,W)30	CAP**6021A**	58MEB100-20	58,000	11.0	13.00	57,000	3.52	7.7	36,000	2.52
3253559	25HBB360(A,W)30	CAP**6021A**	58MV(B,C)100-20	57,500	10.8	13.00	57,500	3.46	7.7	36,600	2.48
3253538	25HBB360(A,W)30	CAP**6021A**	58PH*090-16	58,000	11.0	13.00	57,000	3.50	7.7	36,200	2.50
3253539	25HBB360(A,W)30	CAP**6021A**	58PH*110-20	58,500	11.0	13.50	57,000	3.56	7.7	36,200	2.54
3253558	25HBB360(A,W)30	CAP**6021A**+TDR		58,000	10.8	13.00	57,500	3.52	7.7	36,600	2.50
3253563	25HBB360(A,W)30	CAP**6024A**	58CV(A,X)135-22	58,000	11.0	13.20	57,000	3.54	7.7	36,200	2.54
3253564	25HBB360(A,W)30	CAP**6024A**	58CV(A,X)155-22	58,500	11.2	13.50	57,000	3.58	7.7	36,000	2.56
3253550	25HBB360(A,W)30	CAP**6024A**	58MEB120-20	58,000	11.0	13.50	57,000	3.52	7.7	36,000	2.54
3253562	25HBB360(A,W)30	CAP**6024A**	58MV(B,C)120-20	57,500	10.8	13.00	57,500	3.46	7.7	36,600	2.48
3253540	25HBB360(A,W)30	CAP**6024A**	58PH*135-20	58,000	11.0	13.00	57,000	3.50	7.7	36,200	2.52
3253561	25HBB360(A,W)30	CAP**6024A**+TDR		58,000	10.8	13.00	57,500	3.52	7.7	36,600	2.50
3253571	25HBB360(A,W)30	CNPV*6024A**	58CV(A,X)110-20	58,000	11.0	13.20	57,500	3.48	7.7	36,200	2.50
3253572	25HBB360(A,W)30	CNPV*6024A**	58CV(A,X)135-22	58,000	11.0	13.20	57,500	3.52	7.7	36,000	2.54
3253573	25HBB360(A,W)30	CNPV*6024A**	58CV(A,X)155-22	58,000	11.2	13.50	57,500	3.54	7.7	36,000	2.56
3253552	25HBB360(A,W)30	CNPV*6024A**	58MEB080-16	57,500	10.5	13.00	57,500	3.38	7.7	36,200	2.48
3253553	25HBB360(A,W)30	CNPV*6024A**	58MEB100-20	58,000	11.0	13.00	57,500	3.46	7.7	36,000	2.52
3253554	25HBB360(A,W)30	CNPV*6024A**	58MEB120-20	58,000	11.0	13.50	57,000	3.50	7.7	36,000	2.54
3253570	25HBB360(A,W)30	CNPV*6024A**	58MV(B,C)120-20	57,500	10.8	13.00	58,000	3.44	7.7	36,400	2.48
3253542	25HBB360(A,W)30	CNPV*6024A**	58PH*090-16	57,500	11.0	13.00	57,500	3.44	7.7	36,200	2.50
3253543	25HBB360(A,W)30	CNPV*6024A**	58PH*110-20	58,000	11.0	13.50	57,500	3.50	7.7	36,000	2.54
3253544	25HBB360(A,W)30	CNPV*6024A**	58PH*135-20	58,000	11.0	13.00	57,500	3.48	7.7	36,200	2.52
3253569	25HBB360(A,W)30	CNPV*6024A**+TDR		58,000	10.8	13.00	58,000	3.48	7.7	36,600	2.50
3253567	25HBB360(A,W)30	CNPV*6024A**	58CV(A,X)135-22	58,000	11.0	13.20	57,500	3.52	7.7	36,000	2.54
3253568	25HBB360(A,W)30	CNPV*6024A**	58CV(A,X)155-22	58,000	11.2	13.50	57,500	3.54	7.7	36,000	2.56
3253551	25HBB360(A,W)30	CNPV*6024A**	58MEB120-20	58,000	11.0	13.50	57,000	3.50	7.7	36,000	2.54
3253566	25HBB360(A,W)30	CNPV*6024A**	58MV(B,C)120-20	57,500	10.8	13.00	58,000	3.44	7.7	36,400	2.48
3253541	25HBB360(A,W)30	CNPV*6024A**	58PH*135-20	58,000	11.0	13.00	57,500	3.48	7.7	36,200	2.52
3253565	25HBB360(A,W)30	CNPV*6024A**+TDR		58,000	10.8	13.00	58,000	3.48	7.7	36,600	2.50
3253577	25HBB360(A,W)30	CSPH*6012A**	58CV(A,X)110-20	58,500	11.0	13.20	58,000	3.56	7.7	36,400	2.54
3253578	25HBB360(A,W)30	CSPH*6012A**	58CV(A,X)135-22	58,500	11.2	13.50	57,500	3.58	7.7	36,200	2.56
3253579	25HBB360(A,W)30	CSPH*6012A**	58CV(A,X)155-22	58,500	11.2	13.50	57,500	3.62	7.7	36,000	2.58
3253555	25HBB360(A,W)30	CSPH*6012A**	58MEB080-16	57,500	10.5	13.00	57,500	3.46	7.7	36,200	2.50
3253556	25HBB360(A,W)30	CSPH*6012A**	58MEB100-20	58,000	11.0	13.50	57,500	3.54	7.7	36,200	2.54
3253557	25HBB360(A,W)30	CSPH*6012A**	58MEB120-20	58,500	11.0	13.50	57,500	3.58	7.8	36,000	2.56
3253575	25HBB360(A,W)30	CSPH*6012A**	58MV(B,C)100-20	58,000	10.8	13.00	58,000	3.48	7.7	36,600	2.48
3253576	25HBB360(A,W)30	CSPH*6012A**	58MV(B,C)120-20	58,000	10.8	13.00	58,000	3.50	7.7	36,400	2.50
3253545	25HBB360(A,W)30	CSPH*6012A**	58PH*090-16	58,000	11.0	13.00	57,500	3.52	7.7	36,200	2.52
3253546	25HBB360(A,W)30	CSPH*6012A**	58PH*110-20	58,500	11.0	13.50	57,500	3.60	7.7	36,200	2.56
3253547	25HBB360(A,W)30	CSPH*6012A**	58PH*135-20	58,500	11.0	13.00	57,500	3.56	7.7	36,200	2.54
3253574	25HBB360(A,W)30	CSPH*6012A**+TDR		58,500	10.8	13.00	58,000	3.56	7.7	36,600	2.52

* Ratings are net values reflecting the effects of circulating fan heat. Supplemental electric heat is not included. Ratings are based on:
Cooling Standard: 80°F (27°C) db 67°F (19°C) wb indoor entering air temperature and 95°F (35°C) db air entering outdoor unit.
High-Temp Heating Standard: 70°F (21°C) db indoor entering air temperature and 47°F (8°C) db 43°F (6°C) wb air entering outdoor unit.
Low-Temp Heating Standard: 70°F (21°C) db indoor entering air temperature and 17°F (-8°C) db 15°F (-9°C) wb air entering outdoor unit.

COP — Coefficient of Performance
EER — Energy Efficiency Ratio
HSPF — Heating Seasonal Performance Factor
SEER — Seasonal Energy Efficiency Ratio
TDR — Time-Delay Relay
UI — User Interface

25HBB3

DETAILED COOLING CAPACITIES#

EVAPORATOR AIR		CONDENSER ENTERING AIR TEMPERATURES ° F (° C)																	
		75 (23.9)		85 (29.4)		95 (35)		105 (40.6)		115 (46.1)		125 (51.7)							
CFM	EWB ° F (° C)	Capacity MBtuh		Total System KW**	Capacity MBtuh		Total System KW**	Capacity MBtuh		Total System KW**	Capacity MBtuh		Total System KW**						
		Total	Sens†		Total	Sens†		Total	Sens†		Total	Sens†							
25HBB318(A)W30 Outdoor Section With FY4ANF018 Indoor Section																			
	72 (22.2)	20.67	10.45	1.27	19.67	10.06	1.41	18.62	9.67	1.57	17.52	9.26	1.75	16.35	8.83	1.95	15.07	8.36	2.16
	67 (19.4)	18.85	12.98	1.27	17.92	12.58	1.42	16.94	12.17	1.58	15.91	11.74	1.76	14.81	11.29	1.96	13.62	10.80	2.17
525	63 (17.2)††	17.51	12.54	1.26	16.63	12.14	1.42	15.71	11.73	1.59	14.73	11.29	1.76	13.69	10.83	1.96	12.57	10.34	2.17
	62 (16.7)	17.17	15.48	1.28	16.31	15.06	1.43	15.42	14.61	1.59	14.49	14.12	1.77	13.59	13.59	1.96	12.88	12.88	2.17
	57 (13.9)	16.59	16.59	1.28	15.91	15.91	1.43	15.18	15.18	1.59	14.41	14.41	1.77	13.59	13.59	1.96	12.68	12.68	2.17
	72 (22.2)	21.03	10.92	1.29	19.99	10.53	1.44	18.89	10.13	1.60	17.76	9.71	1.78	16.55	9.28	1.98	15.23	8.81	2.19
600	67 (19.4)	19.19	13.77	1.30	18.22	13.37	1.45	17.20	12.95	1.61	16.13	12.51	1.79	15.01	12.06	1.98	13.78	11.56	2.20
	63 (17.2)††	17.84	13.29	1.30	16.93	12.89	1.45	15.96	12.46	1.61	14.95	12.02	1.79	13.88	11.55	1.99	12.72	11.05	2.20
	62 (16.7)	17.53	16.55	1.31	16.65	16.09	1.45	15.76	15.76	1.61	14.93	14.93	1.79	14.06	14.06	1.99	13.10	13.10	2.20
	57 (13.9)	17.25	17.25	1.31	16.52	16.52	1.45	15.75	15.75	1.61	14.94	14.94	1.79	14.06	14.06	1.99	13.10	13.10	2.20
	72 (22.2)	21.29	11.37	1.32	20.22	10.97	1.47	19.09	10.57	1.63	17.93	10.15	1.81	16.69	9.71	2.00	15.34	9.24	2.22
675	67 (19.4)	19.44	14.53	1.33	18.44	14.12	1.47	17.39	13.70	1.63	16.30	13.25	1.81	15.14	12.78	2.01	13.89	12.27	2.22
	63 (17.2)††	18.09	14.01	1.33	17.14	13.59	1.48	16.15	13.16	1.64	15.12	12.71	1.82	14.02	12.22	2.02	12.84	11.70	2.23
	62 (16.7)	17.84	17.70	1.33	17.02	17.02	1.48	16.21	16.21	1.64	15.36	15.36	1.82	14.45	14.45	2.01	13.44	13.44	2.23
	57 (13.9)	17.79	17.79	1.33	17.02	17.02	1.48	16.22	16.22	1.64	15.36	15.36	1.82	14.45	14.45	2.01	13.44	13.44	2.23

COOLING INDOOR MODEL	CAPACITY	POWER	FURNACE MODEL
CNPV*2417A**	1.01	0.90	58MV(B.C)040-14
CSPH*2412A**	1.02	0.91	58MV(B.C)040-14
CAP**2417A**	1.01	0.90	58MV(B.C)060-14
CNPV*2417A**	1.01	0.90	58MV(B.C)060-14
CNPV*2417A**	1.01	0.90	58MV(B.C)060-14
CSPH*2412A**	1.02	0.91	58MV(B.C)060-14
CNPV*2417A**	1.01	0.90	58MV(B.C)060-14
CSPH*2412A**	1.02	0.91	58MV(B.C)060-14
CAP**1814A**	1.00	0.93	58PH*045-08
CAP**2414A**	1.01	0.90	58PH*045-08
CNPV*2417A**	1.01	0.90	58PH*045-08
CNPV*1814A**	1.00	0.93	58PH*045-08
CNPV*2414A**	1.01	0.90	58PH*045-08
CSPH*2412A**	1.01	0.90	58PH*045-08

COOLING INDOOR MODEL	CAPACITY	POWER	FURNACE MODEL
*FY4ANF018	1.00	1.00	
FE4ANF002	1.03	0.92	
FF1ENP018	1.00	1.01	
FF1ENP024	1.01	1.00	
FV4BNF002	1.03	0.92	
FX4CNF018	1.01	0.94	
FX4CNF024	1.02	0.91	
FY4ANF024	1.01	1.02	
CAP**2414A**	1.02	1.01	
CAP**2417A**	1.02	1.01	
CNPF*2418A**	1.02	1.01	
CNPV*2417A**	1.02	1.01	
CNPV*1814A**	1.01	1.00	
CNPV*2414A**	1.02	1.01	
CNPV*2417A**	1.02	1.01	
CSPH*2412A**	1.03	1.02	
CAP**1814A**	0.99	0.93	58CV(A.X)070-12
CAP**2414A**	1.01	0.90	58CV(A.X)070-12
CNPV*2417A**	1.01	0.90	58CV(A.X)070-12
CNPV*1814A**	1.01	0.94	58CV(A.X)070-12
CNPV*2414A**	1.01	0.90	58CV(A.X)070-12
CSPH*2412A**	1.02	0.91	58CV(A.X)070-12
CAP**2417A**	1.01	0.90	58CV(A.X)090-16
CNPV*2417A**	1.02	0.91	58CV(A.X)090-16
CNPV*2417A**	1.02	0.91	58CV(A.X)090-16
CSPH*2412A**	1.02	0.91	58CV(A.X)090-16
CAP**2417A**	1.05	0.93	58MEB040-12
CNPV*2417A**	1.04	0.93	58MEB040-12
CNPV*2417A**	1.04	0.93	58MEB040-12
CSPH*2412A**	1.04	0.93	58MEB040-12
CAP**2417A**	1.04	0.93	58MEB060-12
CNPV*2417A**	1.02	0.91	58MEB060-12
CNPV*2417A**	1.02	0.91	58MEB060-12
CSPH*2412A**	1.02	0.91	58MEB060-12

See notes on page 33



DETAILED COOLING CAPACITIES# CONTINUED

25HBB330(A,W)30 Outdoor Section With F14ANF030 Indoor Section

COOLING INDOOR MODEL	CAPACITY	POWER	FURNACE MODEL
CSPH*3612A**	1.00	0.94	58MV(B,C)080-14
CAP**3621A**	1.00	0.94	58MV(B,C)080-20
CNPV*3017A**	1.00	0.94	58MV(B,C)080-20
CNPV*3617A**	1.00	0.94	58MV(B,C)080-20
CNPV*3621A**	1.00	0.94	58MV(B,C)080-20
CSPH*3012A**	1.00	0.94	58MV(B,C)080-20
CAP**3621A**	1.00	0.94	58MV(B,C)100-20
CNPV*3017A**	1.00	0.94	58MV(B,C)100-20
CNPV*3617A**	1.00	0.94	58MV(B,C)100-20
CNPV*3621A**	1.00	0.94	58MV(B,C)100-20
CSPH*3012A**	1.00	0.94	58MV(B,C)100-20
CAP**3617A**	1.00	0.94	58PH*070-16
CNPV*3617A**	1.00	0.94	58PH*070-16
CNPV*3017A**	1.00	0.94	58PH*070-16
CNPV*3617A**	1.00	0.94	58PH*070-16
CNPV*3621A**	1.00	0.94	58PH*070-16
CSPH*3012A**	1.00	0.94	58PH*070-16
CAP**3621A**	1.00	0.94	58PH*070-16
CNPV*3017A**	1.00	0.94	58PH*090-16
CNPV*3617A**	1.00	0.94	58PH*090-16
CNPV*3621A**	1.00	0.94	58PH*090-16
CSPH*3012A**	1.00	0.94	58PH*090-16
CSPH*3612A**	1.00	0.90	58PH*090-16

See notes on page 33

DETAILED COOLING CAPACITIES# CONTINUED

25HBB336(A,W)30 Outdoor Section With FY4ANF036 Indoor Section

COOLING INDOOR MODEL	CAPACITY	POWER	FURNACE MODEL
CAP**4224A**	1.00	0.91	58MV(B,C)120-20
CNPH*3617A**	0.99	0.90	58MV(B,C)120-20
CNPH*4221A**	1.00	0.91	58MV(B,C)120-20
CSPH*3612A**	1.01	0.92	58MV(B,C)120-20
CSPH*4212A**	1.02	0.91	58MV(B,C)120-20
CAP**3614A**	0.98	0.95	58PH*045-08
CNPH*3617A**	0.98	0.95	58PH*045-08
CNPH*4221A**	1.00	0.95	58PH*045-08
CSPH*3612A**	1.01	0.97	58PH*045-08
CSPH*4212A**	1.02	0.97	58PH*045-08
CAP**3617A**	0.99	0.93	58PH*070-16
CNPH*3617A**	0.99	0.93	58PH*070-16
CNPH*4221A**	1.00	0.95	58PH*070-16
CNPV*3617A**	0.99	0.93	58PH*070-16
CNPV*4217A**	1.01	0.94	58PH*070-16
CSPH*3612A**	1.01	0.95	58PH*070-16
CSPH*4212A**	1.02	0.93	58PH*070-16
CAP**3621A**	1.01	0.92	58PH*090-16
CAP**4221A**	1.01	0.92	58PH*090-16
CNPH*3617A**	0.99	0.91	58PH*090-16
CNPH*4221A**	1.01	0.92	58PH*090-16
CNPV*3621A**	1.00	0.91	58PH*090-16
CNPV*4221A**	1.01	0.92	58PH*090-16
CSPH*3612A**	1.02	0.93	58PH*090-16
CSPH*4212A**	1.03	0.94	58PH*090-16
CAP**3621A**	1.01	0.92	58PH*110-20
CAP**4221A**	1.02	0.93	58PH*110-20
CNPH*3617A**	1.00	0.91	58PH*110-20
CNPH*4221A**	1.01	0.92	58PH*110-20
CNPV*3621A**	1.00	0.91	58PH*110-20
CNPV*4221A**	1.01	0.92	58PH*110-20
CSPH*3612A**	1.02	0.93	58PH*110-20
CSPH*4212A**	1.03	0.94	58PH*110-20

See notes on page 33

DETAILED COOLING CAPACITIES# CONTINUED

25HBB342(A,W)30 Outdoor Section With FY4ANF042 Indoor Section

COOLING INDOOR MODEL	CAPACITY	POWER	FURNACE MODEL
CSPH*4812A**	1.01	0.92	58PH*135-20

See notes on page 33

COOLING INDOOR MODEL	CAPACITY	POWER	FURNACE MODEL
CAP**4821A**	1.00	0.91	58MV(B,C)080-14
CNPH*4221A**	0.99	0.93	58MV(B,C)080-14
CNPH*4821A**	1.00	0.94	58MV(B,C)080-14
CNPV*4221A**	0.99	0.93	58MV(B,C)080-14
CNPV*4821A**	1.00	0.94	58MV(B,C)080-14
CSPH*4212A**	0.98	0.91	58MV(B,C)080-14
CSPH*4812A**	1.00	0.94	58MV(B,C)080-14
CAP**4221A**	0.99	0.93	58MV(B,C)080-20
CAP**4821A**	1.00	0.93	58MV(B,C)080-20
CNPH*4221A**	0.99	0.92	58MV(B,C)080-20
CNPH*4821A**	1.00	0.93	58MV(B,C)080-20
CNPV*4221A**	0.98	0.91	58MV(B,C)080-20
CNPV*4821A**	1.00	0.93	58MV(B,C)080-20
CSPH*4212A**	0.99	0.92	58MV(B,C)080-20
CSPH*4812A**	1.00	0.92	58MV(B,C)080-20
CAP**4221A**	0.99	0.92	58MV(B,C)100-20
CAP**4821A**	1.00	0.92	58MV(B,C)100-20
CNPH*4221A**	0.99	0.90	58MV(B,C)100-20
CNPH*4821A**	1.00	0.91	58MV(B,C)100-20
CNPV*4221A**	0.99	0.90	58MV(B,C)100-20
CNPV*4821A**	1.00	0.91	58MV(B,C)100-20
CSPH*4212A**	0.99	0.91	58MV(B,C)100-20
CSPH*4812A**	1.00	0.92	58MV(B,C)100-20
CAP**4224A**	0.99	0.92	58MV(B,C)120-20
CAP**4824A**	1.00	0.91	58MV(B,C)120-20
CNPH*4221A**	0.99	0.90	58MV(B,C)120-20
CNPH*4821A**	1.00	0.91	58MV(B,C)120-20
CNPV*4824A**	1.00	0.91	58MV(B,C)120-20
CSPH*4212A**	0.99	0.90	58MV(B,C)120-20
CSPH*4812A**	1.00	0.91	58MV(B,C)120-20
CAP**4817A**	1.01	0.96	58PH*070-16
CNPH*4221A**	0.99	0.98	58PH*070-16
CNPH*4821A**	1.01	0.96	58PH*070-16
CNPV*4217A**	0.99	0.98	58PH*070-16
CNPV*4817A**	1.01	0.96	58PH*070-16
CSPH*4212A**	1.01	0.96	58PH*070-16
CSPH*4812A**	1.01	0.96	58PH*070-16
CAP**4221A**	0.99	0.89	58PH*090-16
CAP**4821A**	1.01	0.92	58PH*090-16
CNPH*4221A**	0.99	0.93	58PH*090-16
CNPH*4821A**	1.01	0.92	58PH*090-16
CNPV*4221A**	0.99	0.93	58PH*090-16
CNPV*4821A**	1.01	0.92	58PH*090-16
CSPH*4212A**	1.01	0.92	58PH*090-16
CSPH*4812A**	1.01	0.92	58PH*090-16
CAP**4221A**	1.00	0.90	58PH*110-20
CAP**4821A**	1.01	0.92	58PH*110-20
CNPH*4221A**	0.99	0.89	58PH*110-20
CNPH*4821A**	1.01	0.92	58PH*110-20
CNPV*4221A**	0.99	0.93	58PH*110-20
CNPV*4821A**	1.01	0.92	58PH*110-20
CSPH*4212A**	1.01	0.92	58PH*110-20
CSPH*4812A**	1.02	0.93	58PH*110-20
CAP**4224A**	1.00	0.90	58PH*135-20
CAP**4824A**	1.01	0.92	58PH*135-20
CNPH*4221A**	0.99	0.93	58PH*135-20
CNPH*4821A**	1.01	0.92	58PH*135-20
CNPV*4824A**	1.01	0.92	58PH*135-20
CSPH*4212A**	1.01	0.92	58PH*135-20

DETAILED COOLING CAPACITIES# CONTINUED

EVAPORATOR AIR	CONDENSER ENTERING AIR TEMPERATURES ° F (° C)																							
	75 (23.9)				85 (29.4)				95 (35)				105 (40.6)				115 (46.1)				125 (51.7)			
	CFM	EWB ° F (° C)	Capacity MBtuh		Total System KW**	Capacity MBtuh		Total System KW**	Capacity MBtuh		Total System KW**	Capacity MBtuh		Total System KW**	Capacity MBtuh		Total System KW**	Capacity MBtuh		Total System KW**				
			Total	Sens†		Total	Sens†		Total	Sens†		Total	Sens†		Total	Sens†								
	72 (22.2)	56.99	28.50	3.33	54.20	27.43	3.76	51.28	26.33	4.22	48.25	25.21	4.72	45.04	24.03	5.25	41.55	22.77	5.82					
1400	67 (19.4)	52.08	35.47	3.36	49.50	34.38	3.78	46.83	33.26	4.23	44.04	32.10	4.72	41.11	30.90	5.25	37.92	29.61	5.81					
	63 (17.2)††	48.43	34.32	3.37	46.02	33.22	3.79	43.52	32.10	4.24	40.92	30.94	4.72	38.19	29.75	5.24	35.23	28.46	5.80					
1600	62 (16.7)	47.48	42.35	3.37	45.13	41.21	3.79	42.72	40.01	4.24	40.24	38.73	4.72	37.77	37.77	5.24	35.36	35.36	5.80					
	57 (13.9)	45.85	45.85	3.38	43.97	43.97	3.79	42.02	42.02	4.24	39.96	39.96	4.72	37.77	37.77	5.24	35.36	35.36	5.80					
	72 (22.2)	57.89	29.74	3.41	55.00	28.67	3.84	51.96	27.55	4.30	48.74	26.41	4.80	45.51	25.22	5.34	41.89	23.95	5.90					
	67 (19.4)	52.98	37.62	3.44	50.29	36.51	3.86	47.50	35.36	4.32	44.61	34.19	4.81	41.57	32.96	5.33	38.27	31.63	5.90					
	63 (17.2)††	49.31	36.34	3.45	46.79	35.22	3.87	44.18	34.07	4.32	41.48	32.89	4.81	38.66	31.66	5.33	35.60	30.34	5.89					
	62 (16.7)	48.44	45.27	3.46	46.03	44.02	3.87	43.55	43.55	4.32	41.33	41.33	4.81	39.00	39.00	5.33	36.43	36.43	5.89					
	57 (13.9)	47.61	47.61	3.46	45.61	45.61	3.87	43.52	43.52	4.32	41.33	41.33	4.81	39.01	39.01	5.33	36.44	36.44	5.89					
1800	72 (22.2)	58.54	30.92	3.49	55.56	29.83	3.92	52.43	28.71	4.39	49.21	27.56	4.89	45.80	26.36	5.42	42.10	25.07	5.99					
	67 (19.4)	53.62	39.66	3.52	50.84	38.53	3.95	47.96	37.36	4.40	44.99	36.17	4.90	41.88	34.91	5.42	38.50	33.54	5.99					
	63 (17.2)††	49.95	38.25	3.54	47.35	37.12	3.96	44.66	35.95	4.41	41.88	34.74	4.90	38.98	33.48	5.42	35.85	32.10	5.98					
	62 (16.7)	49.26	47.81	3.54	46.95	46.95	3.96	44.75	44.75	4.41	42.44	42.44	4.90	39.99	39.99	5.42	37.27	37.27	5.98					
	57 (13.9)	49.06	49.06	3.54	46.96	46.96	3.96	44.75	44.75	4.41	42.44	42.44	4.90	39.99	39.99	5.42	37.28	37.28	5.98					

COOLING INDOOR MODEL	CAPACITY	POWER	FURNACE MODEL
*FYAANF048	1.00	1.00	58CV(A,X)135-22
FE4AN(B,F)005	1.00	0.92	58CV(A,X)135-22
FE4AN(B)006	1.01	0.93	58CV(A,X)135-22
FV4BN(B,F)005	1.00	0.92	58CV(A,X)135-22
FV4BN(B)006	1.01	0.93	58CV(A,X)135-22
FX4CN(B,F)048	1.01	0.93	58CV(A,X)155-22
FX4CN(B,F)060	1.02	0.94	58CV(A,X)155-22
FY4AN(B)060	1.01	0.97	58CV(A,X)155-22
CAP**4817A**	0.98	0.98	58CV(A,X)155-22
CAP**4821A**	0.99	0.99	58CV(A,X)155-22
CAP**4824A**	0.99	0.99	58CV(A,X)155-22
CAP**6021A**	1.01	0.97	58CV(A,X)155-22
CAP**6024A**	1.01	0.97	58CV(A,X)155-22
CNP**4818A**	0.97	0.97	58MEB080-16
CNP**4821A**	0.99	0.99	58MEB080-16
CNP**6024A**	0.99	0.97	58MEB080-16
CNP**4821A**	0.99	0.99	58MEB080-16
CNP**4824A**	0.99	0.99	58MEB080-16
CNP**6024A**	1.01	0.97	58MEB100-20
CNP**4817A**	0.98	0.90	58CV(A,X)090-16
CNP**4821A**	0.98	0.90	58CV(A,X)090-16
CNP**6024A**	1.00	0.92	58CV(A,X)090-16
CNP**4817A**	0.99	0.91	58CV(A,X)110-20
CNP**4821A**	0.99	0.92	58CV(A,X)110-20
CNP**6024A**	1.00	0.92	58CV(A,X)110-20
CNP**4817A**	0.99	0.91	58CV(A,X)110-20
CNP**4821A**	0.99	0.92	58CV(A,X)110-20
CNP**6024A**	1.00	0.92	58CV(A,X)135-22
CNP**4817A**	0.98	0.90	58CV(A,X)135-22
CNP**4821A**	0.98	0.90	58CV(A,X)135-22
CNP**6024A**	1.00	0.92	58CV(A,X)135-22

25HBB3

DETAILED COOLING CAPACITIES# CONTINUED

25HBB348(A,W)30 Outdoor Section With F4ANF048 Indoor Section

COOLING INDOOR MODEL	CAPACITY	POWER	FURNACE MODEL
CNPH*4821A**	0.99	0.91	58PH*135-20
CNPH*4821A**	0.99	0.91	58PH*135-20
CNPH*6024A**	1.01	0.93	58PH*135-20
CNPV*4824A**	0.99	0.91	58PH*135-20
CNPV*6024A**	1.01	0.93	58PH*135-20
CSPH*4812A**	0.99	0.91	58PH*135-20
CSPH*6012A**	1.01	0.93	58PH*135-20

See notes on page 33

DETAILED COOLING CAPACITIES# CONTINUED

EVAPORATOR AIR		CONDENSER ENTERING AIR TEMPERATURES °F (°C)																					
		75 (23.9)				85 (29.4)				95 (35)				105 (40.6)				115 (46.1)				125 (51.7)	
		CFM	EWB °F (°C)	Capacity MBtuh		Total System KW**	Capacity MBtuh		Total System KW**	Capacity MBtuh		Total System KW**	Capacity MBtuh		Total System KW**	Capacity MBtuh		Total System KW**	Capacity MBtuh		Total System KW**		
Total	Sens†			Total	Sens†		Total	Sens†		Total	Sens†		Total	Sens†		Total	Sens†		Total	Sens†			
25HBB360(A,W)30 Outdoor Section With FV4ANB060 Indoor Section																							
	72 (22.2)	70.34	35.38	4.52	67.10	34.14	4.98	63.63	32.83	5.48	60.01	31.48	6.03	56.06	30.03	6.63	51.70	28.45	7.27				
	67 (19.4)	64.72	44.25	4.46	61.72	42.98	4.92	58.50	41.62	5.42	55.15	40.23	5.97	51.50	38.73	6.52	47.50	37.11	7.21				
1750	63 (17.2)††	60.52	42.98	4.41	57.88	41.67	4.87	54.66	40.31	5.37	51.50	38.90	5.92	48.09	37.40	6.52	44.37	35.78	7.17				
	62 (16.7)	59.39	53.03	4.40	56.60	51.67	4.86	53.67	50.23	5.36	50.63	48.68	5.91	47.46	47.46	6.51	44.40	44.40	7.17				
	57 (13.9)	57.36	37.96	4.38	55.12	35.64	4.84	52.73	34.31	5.35	50.21	32.95	5.90	47.45	47.45	6.51	44.40	44.40	7.17				
	72 (22.2)	71.28	36.87	4.64	67.97	35.64	5.09	64.37	34.31	5.59	60.64	32.95	6.14	56.56	31.48	6.74	52.07	29.88	7.39				
	67 (19.4)	65.71	46.88	4.58	62.80	45.59	5.03	59.26	44.22	5.53	55.79	42.80	6.08	52.01	41.28	6.69	47.89	39.62	7.33				
2000	63 (17.2)††	61.54	45.45	4.53	58.58	44.14	4.99	55.44	42.75	5.49	52.17	41.32	6.04	48.63	39.78	6.64	44.80	38.11	7.28				
	62 (16.7)	60.48	56.64	4.52	57.63	55.18	4.98	54.66	54.31	5.48	51.85	51.85	6.03	48.91	48.91	6.64	45.66	45.66	7.30				
	57 (13.9)	59.46	59.46	4.51	57.07	57.07	4.97	54.53	54.53	5.48	51.85	51.85	6.03	48.92	48.92	6.64	45.67	45.67	7.30				
	72 (22.2)	71.96	36.30	4.75	68.56	37.06	5.21	64.87	35.72	5.71	61.04	34.35	6.26	56.86	32.67	6.86	52.26	31.26	7.50				
	67 (19.4)	66.40	49.38	4.70	63.21	48.09	5.15	59.77	46.69	5.65	56.21	45.25	6.20	52.34	43.69	6.80	48.13	41.98	7.44				
2250	63 (17.2)††	62.26	47.81	4.65	59.21	46.48	5.10	55.98	45.06	5.60	52.62	43.60	6.15	49.00	42.02	6.75	45.07	40.30	7.40				
	62 (16.7)	61.41	58.80	4.64	58.65	58.65	5.10	55.97	55.97	5.61	53.15	53.15	6.16	50.06	50.06	6.77	46.64	46.64	7.42				
	57 (13.9)	61.16	61.16	4.64	58.65	58.65	5.10	55.97	55.97	5.61	53.16	53.16	6.16	50.07	50.07	6.77	46.65	46.65	7.42				

COOLING INDOOR MODEL	CAPACITY	POWER	FURNACE MODEL	COOLING INDOOR MODEL		POWER	FURNACE MODEL	COOLING INDOOR MODEL		POWER	FURNACE MODEL	COOLING INDOOR MODEL		POWER	FURNACE MODEL
				INDOOR MODEL	POWER			INDOOR MODEL	POWER			INDOOR MODEL	POWER		
*FY4ANB060	1.00	1.00		CSPH*6012A**	1.00	0.96	58CV(A,X)135-22	CSPH*6012A**	0.99	0.99	58MV(B,C)100-20	CSPH*6012A**	0.99	0.99	58MV(B,C)100-20
FV4ANB006	1.02	0.98		CAP**6024A**	1.00	0.96	58CV(A,X)155-22	CAP**6024A**	0.99	0.98	58MV(B,C)120-20	CAP**6024A**	0.98	0.98	58MV(B,C)120-20
FV4ANB006	1.02	0.98		CNPV*6024A**	0.99	0.96	58CV(A,X)155-22	CNPV*6024A**	0.99	0.98	58MV(B,C)120-20	CNPV*6024A**	0.98	0.98	58MV(B,C)120-20
FX4CN(B,F)060	1.01	0.97		CSPH*6012A**	1.00	0.96	58CV(A,X)155-22	CSPH*6012A**	0.99	0.99	58MV(B,C)120-20	CSPH*6012A**	0.99	0.99	58MV(B,C)120-20
CAP**6021A**	0.99	0.99		CNPV*6024A**	0.98	1.01	58MEB080-16	CNPV*6024A**	0.99	0.97	58PH*090-16	CNPV*6024A**	0.97	0.97	58PH*090-16
CNPV*6024A**	0.99	0.99		CAP**6021A**	0.98	1.01	58MEB080-16	CAP**6021A**	0.99	0.97	58PH*090-16	CAP**6021A**	0.97	0.97	58PH*090-16
CNPV*6024A**	0.99	0.99		CNPV*6012A**	0.99	0.97	58MEB100-20	CNPV*6012A**	0.99	0.97	58PH*110-20	CNPV*6012A**	0.99	0.97	58PH*110-20
CNPV*6024A**	0.99	0.99		CAP**6024A**	0.99	0.97	58MEB100-20	CAP**6024A**	0.99	0.97	58PH*110-20	CAP**6024A**	0.99	0.97	58PH*110-20
CNPV*6024A**	0.99	0.97	58CV(A,X)110-20	CNPV*6012A**	0.99	0.97	58MEB120-20	CNPV*6012A**	0.99	0.97	58PH*135-20	CNPV*6012A**	0.99	0.97	58PH*135-20
CNPV*6024A**	0.99	0.97	58CV(A,X)110-20	CAP**6024A**	0.99	0.97	58MEB120-20	CAP**6024A**	0.99	0.97	58PH*135-20	CAP**6024A**	0.99	0.97	58PH*135-20
CNPV*6024A**	0.99	0.97	58CV(A,X)135-22	CNPV*6012A**	1.00	0.98	58MEB120-20	CNPV*6012A**	1.00	0.98	58PH*135-20	CNPV*6012A**	1.00	0.98	58PH*135-20
CNPV*6024A**	0.99	0.97	58CV(A,X)135-22	CAP**6021A**	0.98	0.98	58MV(B,C)100-20	CAP**6021A**	0.98	0.98	58PH*135-20	CAP**6021A**	1.00	0.98	58PH*135-20

* Tested combination.

† Total and sensible capacities are net capacities. Blower motor heat has been subtracted.

‡ Sensible capacities shown are based on 80°F (27°C) entering air at the indoor coil. For sensible capacities at other than 80°F (27°C), deduct 835 Btuh (245 kW) per 1000 CFM (480 L/S) of indoor coil air for each degree below 80°F (27°C), or add 835 Btuh (245 kW) per 1000 CFM (480 L/S) of indoor coil air per degree above 80°F (27°C).

Detailed cooling capacities are based on indoor and outdoor unit at the same elevation per ARI standard 210/240--2008. If additional tubing length and/or indoor unit is located above outdoor unit, a slight variation in capacity may occur.

** System kw is total of indoor and outdoor unit kilowatts.

†† At TVA rating indoor condition (75°F edb/63°F ewb). All other indoor air temperatures are at 80°F edb.

NOTE: When the required data falls between the published data, interpolation may be performed. Extrapolation is not an acceptable practice.

EWB — Entering Wet Bulb



25HBB3

HEAT PUMP HEATING PERFORMANCE

INDOOR AIR		OUTDOOR COIL ENTERING AIR TEMPERATURES °F (°C)																							
EDB °F (°C)	CFM	-3 (-19.4)		7 (-13.9)		17 (-8.3)		27 (-2.8)		37 (2.8)		47 (8.3)		57 (13.9)		67 (19.4)									
		Capacity MBtuh Total	Integ*	Capacity MBtuh Total	Integ*	Capacity MBtuh Total	Integ*	Capacity MBtuh Total	Integ*	Capacity MBtuh Total	Integ*	Capacity MBtuh Total	Integ*	Capacity MBtuh Total	Integ*	Capacity MBtuh Total	Integ*								
65 (18.3)	525	6.57	6.04	1.23	8.48	7.79	1.28	10.53	9.60	1.33	12.74	11.31	1.39	15.25	13.88	1.46	18.04	16.55	1.55	20.79	18.04	1.63	23.40	20.79	1.72
	600	6.72	6.19	1.25	8.66	7.95	1.29	10.71	9.77	1.34	12.99	11.53	1.39	15.57	14.17	1.45	18.34	15.53	1.53	20.88	18.34	1.59	23.48	20.88	1.67
	675	6.87	6.32	1.26	8.81	8.10	1.31	10.89	9.93	1.35	13.20	11.72	1.39	15.81	14.39	1.45	18.61	15.81	1.51	20.94	18.61	1.57	23.41	20.94	1.64
70 (21.1)	525	6.23	5.74	1.28	8.18	7.52	1.33	10.24	9.34	1.39	12.44	11.05	1.45	14.90	13.56	1.53	17.66	14.90	1.62	20.52	17.66	1.71	23.10	20.52	1.80
	600	6.39	5.88	1.29	8.36	7.68	1.34	10.42	9.50	1.40	12.66	11.25	1.45	15.19	13.83	1.52	18.00	15.19	1.60	20.69	18.00	1.67	23.24	20.69	1.75
	675	6.52	6.00	1.31	8.52	7.83	1.36	10.60	9.66	1.40	12.88	11.44	1.45	15.45	14.06	1.51	18.28	15.45	1.58	20.73	18.28	1.64	23.25	20.73	1.72
75 (23.9)	525	5.89	5.42	1.32	7.86	7.23	1.39	9.94	9.06	1.45	12.15	10.79	1.52	14.55	13.24	1.59	17.31	14.55	1.69	20.20	17.31	1.79	22.78	20.20	1.88
	600	6.05	5.56	1.34	8.02	7.37	1.40	10.11	9.22	1.46	12.38	10.99	1.51	14.85	13.51	1.58	17.63	14.85	1.67	20.45	17.63	1.75	22.97	20.45	1.83
	675	6.19	5.69	1.36	8.20	7.54	1.41	10.29	9.39	1.46	12.58	11.17	1.52	15.09	13.73	1.58	17.92	15.09	1.66	20.55	17.92	1.72	23.03	20.55	1.80

25HBB318(A,W)30 Outdoor Section With FY4ANF018 Indoor Section

HEATING INDOOR MODEL	HEATING INDOOR MODEL	CAPACITY	POWER	FURNACE MODEL
FY4ANF018	CNPH*2417A**	0.97	0.89	58PH*045-08
FE4ANF002	CNPV*1814A**	0.97	0.92	58PH*045-08
FF1ENP018	CNPV*2414A**	0.97	0.89	58PH*045-08
FF1ENP024	CSPH*2412A**	0.96	0.89	58PH*045-08

See notes on page 43

HEATING INDOOR MODEL	CAPACITY	POWER	FURNACE MODEL
FY4ANF018	1.00	1.00	
FE4ANF002	0.96	0.89	
FF1ENP018	1.00	1.00	
FF1ENP024	1.00	0.98	
FV4BNF002	0.96	0.89	
FY4CNF018	0.97	0.91	
FY4CNF024	0.96	0.89	
FY4ANF024	1.00	1.00	
CAP**2414A**	1.00	0.97	
CAP**2417A**	1.00	0.97	
CNPF*2418A**	1.00	0.96	
CNPH*2417A**	1.00	0.96	
CNPV*1814A**	1.00	0.97	
CNPV*2414A**	1.00	0.96	
CNPV*2417A**	1.00	0.96	
CSPH*2412A**	1.00	0.96	
CAP**1814A**	0.95	0.96	58CV(A,X)070-12
CAP**2414A**	0.97	0.94	58CV(A,X)070-12
CNPH*2417A**	0.97	0.92	58CV(A,X)070-12
CNPV*1814A**	0.97	0.94	58CV(A,X)070-12
CNPV*2414A**	0.97	0.92	58CV(A,X)070-12
CNPH*2412A**	0.97	0.92	58CV(A,X)090-16
CAP**2417A**	0.96	0.92	58CV(A,X)090-16
CNPH*2417A**	0.97	0.92	58CV(A,X)090-16
CSPH*2412A**	0.97	0.92	58CV(A,X)090-16
CAP**2417A**	0.98	0.87	58MEB040-12
CNPH*2417A**	0.98	0.88	58MEB040-12
CNPV*2417A**	0.98	0.88	58MEB040-12
CSPH*2412A**	0.97	0.88	58MEB040-12
CAP**2417A**	0.97	0.88	58MEB060-12
CNPH*2417A**	0.97	0.89	58MEB060-12
CNPV*2417A**	0.97	0.89	58MEB060-12
CSPH*2412A**	0.96	0.91	58MEB060-12
CNPH*2417A**	0.97	0.92	58MV(B,C)040-14
CSPH*2412A**	0.97	0.92	58MV(B,C)060-14
CAP**2417A**	0.97	0.93	58MV(B,C)060-14
CNPH*2417A**	0.97	0.92	58MV(B,C)060-14
CSPH*2412A**	0.97	0.91	58MV(B,C)060-14
CNPH*2417A**	0.97	0.92	58MV(B,C)080-14
CSPH*2412A**	0.97	0.92	58MV(B,C)080-14
CAP**1814A**	0.96	0.94	58PH*045-08
CAP**2414A**	0.97	0.90	58PH*045-08

HEAT PUMP HEATING PERFORMANCE CONTINUED

INDOOR AIR		OUTDOOR COIL ENTERING AIR TEMPERATURES °F (°C)																													
		-3 (-19.4)				7 (-13.9)				17 (-8.3)				27 (-2.8)				37 (2.8)				47 (8.3)				57 (13.9)				67 (19.4)	
EDB °F (°C)	CFM	Capacity MBtu/h		Total Syst. KWt	Capacity MBtu/h		Total Syst. KWt	Capacity MBtu/h		Total Syst. KWt	Capacity MBtu/h		Total Syst. KWt	Capacity MBtu/h		Total Syst. KWt	Capacity MBtu/h		Total Syst. KWt	Capacity MBtu/h		Total Syst. KWt	Capacity MBtu/h		Total Syst. KWt						
		Total	Integ*		Total	Integ*		Total	Integ*		Total	Integ*		Total	Integ*		Total	Integ*		Total	Integ*		Total	Integ*		Total	Integ*	Total	Integ*	Total	Integ*
65 (18.3)	875	12.02	11.06	1.89	15.08	13.85	1.97	18.33	16.72	2.07	21.82	19.38	2.18	25.66	23.35	2.31	29.99	29.99	2.47	34.77	34.77	2.64	39.32	39.32	2.79						
	1000	12.26	11.28	1.90	15.33	14.09	1.98	18.61	16.97	2.06	22.12	19.64	2.16	26.04	23.69	2.28	30.47	30.47	2.42	35.11	35.11	2.55	39.58	39.58	2.69						
	1125	12.47	11.47	1.92	15.56	14.30	1.99	18.86	17.19	2.07	22.38	19.88	2.15	28.41	24.04	2.26	30.87	30.87	2.39	35.28	35.28	2.49	39.69	39.69	2.63						
70 (21.1)	875	11.62	10.69	1.98	14.71	13.52	2.08	17.98	16.40	2.18	21.49	19.08	2.30	25.25	22.98	2.43	29.55	29.55	2.60	34.31	34.31	2.79	38.81	38.81	2.94						
	1000	11.85	10.91	2.00	14.97	13.76	2.08	18.26	16.65	2.17	21.79	19.35	2.28	25.64	23.38	2.40	30.00	30.00	2.55	34.70	34.70	2.69	39.17	39.17	2.83						
	1125	12.07	11.10	2.02	15.20	13.97	2.10	18.51	16.88	2.18	22.05	19.59	2.27	25.97	23.63	2.38	30.39	30.39	2.52	34.94	34.94	2.63	39.35	39.35	2.77						
75 (23.9)	875	11.19	10.29	2.07	14.32	13.16	2.18	17.61	16.06	2.29	21.13	18.77	2.42	24.86	22.62	2.56	29.13	29.13	2.74	33.84	33.84	2.95	38.33	38.33	3.09						
	1000	11.42	10.51	2.09	14.58	13.40	2.19	17.90	16.32	2.29	21.44	19.04	2.40	25.23	22.95	2.52	29.56	29.56	2.68	34.25	34.25	2.84	38.72	38.72	2.98						
	1125	11.64	10.70	2.12	14.82	13.61	2.20	18.15	16.55	2.29	21.72	19.29	2.39	25.55	23.25	2.50	29.93	29.93	2.65	34.55	34.55	2.78	38.96	38.96	2.91						

25HBB330(A,W)30 Outdoor Section With F44ANF030 Indoor Section

HEATING INDOOR MODEL	CAPACITY	POWER	FURNACE MODEL	
			HEATING INDOOR MODEL	POWER
*F44ANF030	1.00	1.00	58CV(A,X)110-20	0.96
FE4AN(B,F)003	0.99	0.96	58CV(A,X)110-20	0.96
FE4ANF002	1.00	0.97	58CV(A,X)110-20	0.96
FF1ENP030	1.00	1.01	58CV(A,X)110-20	0.99
FF1ENP036	1.00	0.99	58CV(A,X)110-20	0.95
FV4BN(B,F)003	0.99	0.96	58CV(A,X)135-22	0.98
FV4CN(B,F)036	1.00	0.96	58CV(A,X)135-22	0.98
FV4CNF030	1.00	0.96	58CV(A,X)135-22	0.99
FV4BNF002	1.00	0.97	58CV(A,X)135-22	0.95
FV4ANF036	1.00	1.00	58CV(A,X)155-22	0.98
CAP**3017A**	1.00	1.00	58CV(A,X)155-22	0.98
CAP**3017A**	1.00	1.00	58CV(A,X)155-22	0.99
CAP**3614A**	1.00	0.99	58CV(A,X)155-22	0.95
CAP**3017A**	1.00	0.99	58MEB040-12	0.97
CAP**3621A**	1.00	0.99	58MEB040-12	0.96
CNP**3618A**	1.00	0.99	58MEB040-12	0.97
CNP**3017A**	1.00	0.99	58MEB040-12	0.97
CNP**3617A**	1.00	0.99	58MEB040-12	0.97
CNP**3014A**	1.00	0.99	58MEB040-12	0.97
CNP**3017A**	1.00	0.99	58MEB040-12	0.97
CNP**3617A**	1.00	0.99	58MEB040-12	0.97
CNP**3617A**	1.00	0.99	58MEB040-12	0.96
CNP**3012A**	1.00	0.99	58MEB040-12	0.96
CSPH**3012A**	1.00	0.99	58MEB040-12	0.96
CSPH**3612A**	1.00	0.95	58MEB040-12	0.97
CAP**3014A**	1.00	1.01	58CV(A,X)070-12	0.99
CAP**3614A**	1.00	1.00	58CV(A,X)070-12	0.99
CNP**3017A**	1.00	1.00	58CV(A,X)070-12	1.00
CNP**3617A**	1.00	1.00	58CV(A,X)070-12	1.00
CNP**3014A**	1.00	1.01	58CV(A,X)070-12	0.99
CSPH**3012A**	1.00	1.00	58CV(A,X)070-12	0.96
CSPH**3612A**	1.00	0.96	58CV(A,X)070-12	0.96
CAP**3017A**	0.99	0.99	58CV(A,X)090-16	0.99
CAP**3617A**	0.99	0.98	58CV(A,X)090-16	0.98
CNP**3017A**	0.99	0.99	58CV(A,X)090-16	0.99
CNP**3617A**	0.99	0.99	58CV(A,X)090-16	0.99
CNP**3017A**	0.99	0.99	58CV(A,X)090-16	0.99
CNP**3617A**	0.99	0.99	58CV(A,X)090-16	0.99
CNP**3012A**	0.99	0.99	58CV(A,X)090-16	0.99
CSPH**3012A**	1.00	0.96	58CV(A,X)090-16	0.96
CSPH**3612A**	1.00	0.96	58CV(A,X)090-16	0.96
CAP**3017A**	1.00	0.99	58CV(A,X)110-20	0.99
CAP**3621A**	0.99	0.98	58CV(A,X)110-20	0.98
CNP**3017A**	1.00	0.99	58PH*3617A**	0.99
CNP**3617A**	1.00	0.99	58PH*3617A**	0.99
CNP**3017A**	1.00	1.00	58PH*3617A**	1.00
CNP**3617A**	1.00	1.00	58PH*3617A**	1.00
CNP**3017A**	1.00	1.00	58PH*3617A**	1.00
CNP**3617A**	1.00	1.00	58PH*3617A**	1.00
CNP**3017A**	1.00	1.00	58PH*3617A**	1.00
CNP**3617A**	1.00	1.00	58PH*3617A**	1.00
CNP**3017A**	1.00	1.00	58PH*3617A**	1.00
CNP**3617A**	1.00	1.00	58PH*3617A**	1.00
CNP**3017A**	1.00	1.00	58PH*3617A**	1.00
CNP**3617A**	1.00	1.00	58PH*3617A**	1.00
CNP**3017A**	1.00	1.00	58PH*3617A**	1.00
CNP**3617A**	1.00	1.00	58PH*3617A**	1.00
CNP**3017A**	1.00	1.00	58PH*3617A**	1.00
CNP**3617A**	1.00	1.00	58PH*3617A**	1.00
CNP**3017A**	1.00	1.00	58PH*3617A**	1.00
CNP**3617A**	1.00	1.00	58PH*3617A**	1.00
CNP**3017A**	1.00	1.00	58PH*3617A**	1.00
CNP**3617A**	1.00	1.00	58PH*3617A**	1.00

HEAT PUMP HEATING PERFORMANCE CONTINUED

25HBB30(A,W)30 Outdoor Section With FY4ANF030 Indoor Section

HEATING INDOOR MODEL	CAPACITY	POWER	FURNACE MODEL
CAP**3617A**	1.00	0.98	58PH*070-16
CNPH*3017A**	1.00	0.99	58PH*070-16
CNPH*3617A**	1.00	0.99	58PH*070-16
CNPV*3017A**	1.00	0.99	58PH*070-16
CNPV*3617A**	1.00	0.99	58PH*070-16
CSPH*3012A**	1.00	0.99	58PH*070-16
CSPH*3612A**	1.00	0.94	58PH*070-16
CAP**3621A**	1.00	0.96	58PH*090-16
CNPH*3017A**	1.00	0.98	58PH*090-16
CNPH*3617A**	1.00	0.98	58PH*090-16
CNPV*3621A**	1.00	0.98	58PH*090-16
CSPH*3012A**	1.00	0.99	58PH*090-16
CSPH*3612A**	1.00	0.93	58PH*090-16

See notes on page 43

HEAT PUMP HEATING PERFORMANCE CONTINUED

25HBB336 (A, W)30 Outdoor Section With FY4ANF036 Indoor Section

HEATING INDOOR MODEL	CAPACITY	POWER	FURNACE MODEL
CAP**3617A**	0.98	0.97	58PH*070-16
CNPH*3617A**	0.98	0.98	58PH*070-16
CNPH*4221A**	0.98	0.95	58PH*070-16
CNPV*3617A**	0.98	0.98	58PH*070-16
CNPV*4217A**	0.96	0.93	58PH*070-16
CSPH*3612A**	0.97	0.93	58PH*070-16
CSPH*4212A**	0.95	0.91	58PH*070-16
CAP**3621A**	0.97	0.93	58PH*090-16
CAP**4221A**	0.97	0.92	58PH*090-16
CNPH*3617A**	0.98	0.96	58PH*090-16
CNPH*4221A**	0.97	0.93	58PH*090-16
CNPV*3621A**	0.98	0.95	58PH*090-16
CNPV*4221A**	0.97	0.93	58PH*090-16
CSPH*3612A**	0.96	0.90	58PH*090-16
CSPH*4212A**	0.95	0.88	58PH*090-16
CAP**3621A**	0.97	0.92	58PH*110-20
CAP**4221A**	0.97	0.91	58PH*110-20
CNPH*3617A**	0.98	0.95	58PH*110-20
CNPH*4221A**	0.97	0.91	58PH*110-20
CNPV*3621A**	0.98	0.95	58PH*110-20
CNPV*4221A**	0.97	0.91	58PH*110-20
CSPH*3612A**	0.96	0.90	58PH*110-20
CSPH*4212A**	0.95	0.88	58PH*110-20

See notes on page 43

HEAT PUMP HEATING PERFORMANCE CONTINUED

25HBB34Z(A, W)S0 Outdoor Section With FY4ANF042 Indoor Section

HEATING INDOOR MODEL	CAPACITY	POWER	FURNACE MODEL
CSPH*4812A**	0.98	0.94	58MV(B,C)100-20
CAP**4224A**	0.98	0.99	58MV(B,C)120-20
CAP**4824A**	0.98	0.95	58MV(B,C)120-20
CNPH*4221A**	0.98	0.98	58MV(B,C)120-20
CNPH*4821A**	0.98	0.95	58MV(B,C)120-20
CNPV*4824A**	0.98	0.95	58MV(B,C)120-20
CSPH*4212A**	0.99	0.96	58MV(B,C)120-20
CSPH*4812A**	0.98	0.94	58MV(B,C)120-20
CAP**4817A**	0.99	0.97	58PH*070-16
CNPH*4221A**	1.01	1.04	58PH*070-16
CNPH*4821A**	1.00	0.98	58PH*070-16
CNPV*4217A**	1.01	1.02	58PH*070-16
CSPH*4212A**	1.00	0.98	58PH*070-16
CSPH*4812A**	1.00	0.97	58PH*070-16
CAP**4221A**	0.99	0.99	58PH*090-16
CAP**4821A**	0.99	0.95	58PH*090-16
CNPH*4221A**	0.99	0.99	58PH*090-16
CNPH*4821A**	0.99	0.94	58PH*090-16
CNPV*4221A**	0.99	0.99	58PH*090-16
CNPV*4821A**	1.00	0.95	58PH*090-16
CSPH*4212A**	0.99	0.95	58PH*090-16
CSPH*4812A**	0.99	0.94	58PH*090-16
CAP**4221A**	0.99	0.98	58PH*110-20
CAP**4821A**	0.99	0.94	58PH*110-20
CNPH*4221A**	0.99	0.99	58PH*110-20
CNPH*4821A**	0.99	0.94	58PH*110-20
CNPV*4221A**	0.99	0.99	58PH*110-20
CNPV*4821A**	1.00	0.95	58PH*110-20
CSPH*4212A**	0.99	0.94	58PH*110-20
CSPH*4812A**	0.99	0.94	58PH*110-20
CAP**4224A**	0.99	0.98	58PH*135-20
CAP**4824A**	0.99	0.94	58PH*135-20
CNPH*4221A**	0.99	1.00	58PH*135-20
CNPH*4821A**	0.99	0.94	58PH*135-20
CNPV*4824A**	1.00	0.95	58PH*135-20
CSPH*4212A**	0.99	0.95	58PH*135-20
CSPH*4812A**	0.99	0.94	58PH*135-20

See notes on page 43

HEAT PUMP HEATING PERFORMANCE CONTINUED

INDOOR AIR		OUTDOOR COIL ENTERING AIR TEMPERATURES ° F (° C)																					
		-3 (-19.4)		7 (-13.9)		17 (-8.3)		27 (-2.8)		37 (2.8)		47 (8.3)		57 (13.9)		67 (19.4)							
EDB ° F (° C)	CFM	Capacity MBtuh		Total Sys. KWT		Capacity MBtuh		Total Sys. KWT		Capacity MBtuh		Total Sys. KWT		Capacity MBtuh		Total Sys. KWT							
		Total	Integ*	Total	Integ*	Total	Integ*	Total	Integ*	Total	Integ*	Total	Integ*	Total	Integ*	Total	Integ*						
25HBB360(A,W)30 Outdoor Section With FY4ANB060 Indoor Section																							
65 (18.3)	1750	24.06	22.14	2.98	30.37	27.90	3.14	33.74	3.31	44.09	39.16	3.49	51.99	47.31	3.70	60.58	60.58	3.88					
	2000	24.32	22.37	2.95	30.63	28.14	3.10	37.33	3.24	44.47	39.50	3.41	52.57	47.84	3.59	60.71	60.71	3.75					
	2250	24.52	22.56	2.93	30.87	28.37	3.06	37.59	34.27	44.78	39.77	3.35	53.02	48.24	3.50	60.66	60.66	3.65					
70 (21.1)	1750	23.20	21.34	3.13	29.59	27.19	3.31	36.29	33.09	43.39	38.54	3.68	51.21	46.80	3.91	59.77	59.77	4.10					
	2000	23.45	21.58	3.10	29.88	27.46	3.27	36.63	33.40	43.77	38.87	3.60	51.69	47.04	3.80	60.02	60.02	3.96					
	2250	23.66	21.77	3.08	30.11	27.67	3.23	36.88	33.62	44.07	39.14	3.54	52.16	47.47	3.70	60.03	60.03	3.86					
75 (23.9)	1750	22.27	20.49	3.29	28.76	26.42	3.48	35.52	32.36	42.68	37.91	3.88	50.42	45.89	4.12	58.93	58.93	4.32					
	2000	22.53	20.73	3.26	29.05	26.70	3.44	35.84	32.66	43.07	38.25	3.80	50.92	46.34	4.01	59.25	59.25	4.18					
	2250	22.74	20.92	3.24	29.29	26.92	3.41	36.12	32.93	43.36	38.51	3.74	51.40	46.77	3.92	59.39	59.39	4.07					
HEATING INDOOR MODEL		CAPACITY		POWER		FURNACE MODEL		HEATING INDOOR MODEL		CAPACITY		POWER		FURNACE MODEL		HEATING INDOOR MODEL		CAPACITY		POWER		FURNACE MODEL	
*FY4ANB060		1.00		1.00				CSPH*6012A**		0.99		0.97		58CV(A,X)135-22		CSPH*6012A**		1.00		1.01		58MV(B,C)100-20	
FE4ANB006		0.98		0.94				CAP**6024A**		0.98		0.97		58CV(A,X)155-22		CAP**6024A**		0.99		1.01		58MV(B,C)120-20	
FX4CNB F060		0.99		0.96				CNPV*6024A**		0.99		0.99		58CV(A,X)155-22		CNPV*6024A**		1.00		1.03		58MV(B,C)120-20	
CAP**6021A**		0.99		0.99				CSPH*6012A**		0.99		0.97		58CV(A,X)155-22		CSPH*6012A**		1.00		1.01		58MV(B,C)120-20	
CAP**6024A**		1.00		1.01				CNPV*6024A**		0.99		1.03		58MEB080-16		CAP**6024A**		0.99		0.99		58PH*090-16	
CNPV*6024A**		1.00		1.01				CSPH*6012A**		0.99		1.01		58MEB080-16		CNPV*6024A**		0.99		1.01		58PH*090-16	
CSPH*6012A**		1.00		0.99				CAP**6021A**		0.98		0.99		58MEB100-20		CSPH*6012A**		0.99		0.99		58PH*090-16	
CAP**6021A**		0.99		0.99				CNPV*6024A**		0.99		1.01		58MEB100-20		CAP**6021A**		0.98		0.98		58PH*110-20	
CNPV*6024A**		0.99		0.99				CSPH*6012A**		0.99		0.99		58MEB100-20		CNPV*6024A**		0.99		1.00		58PH*110-20	
CNPV*6024A**		0.99		1.00				CAP**6024A**		0.98		0.98		58MEB120-20		CAP**6024A**		0.99		0.97		58PH*110-20	
CSPH*6012A**		1.00		0.99				CNPV*6024A**		0.98		0.99		58MEB120-20		CNPV*6024A**		0.98		0.99		58PH*135-20	
CAP**6024A**		0.98		0.98				CSPH*6012A**		0.99		0.98		58MEB120-20		CAP**6024A**		0.99		1.01		58PH*135-20	
CNPV*6024A**		0.99		1.00				CAP**6021A**		0.99		1.01		58MV(B,C)100-20		CNPV*6024A**		0.99		0.98		58PH*135-20	

NOTE: When the required data falls between the published data, interpolation may be performed. Extrapolation is not an acceptable practice.

* The Btuh heating capacity values shown are net integrated values from which the defrost effect has been subtracted. The Btuh heating from supplement heaters should be added to those values to obtain total system capacity.

† The kW values include the compressor, outdoor fan motor, and indoor blower motor. The kW from supplement heaters should be added to these values to obtain total system kilowatts.

EDB — Entering Dry Bulb

System Description

Outdoor-mounted, air-cooled, split-system heat pump unit suitable for ground or rooftop installation. Unit consists of a hermetic compressor, an air-cooled coil, propeller-type condenser fan, and a control box. Unit will discharge supply air upward as shown on contract drawings. Unit will be used in a refrigeration circuit to match up to a packaged fan coil or coil unit.

Quality Assurance

- Unit will be rated in accordance with the latest edition of AHRI Standard 240.
- Unit will be certified for capacity and efficiency, and listed in the latest AHRI directory.
- Unit construction will comply with latest edition of ANSI/ASHRAE and with NEC.
- Unit will be constructed in accordance with UL standards and will carry the UL label of approval. Unit will have C-UL approval.
- Unit cabinet will be capable of withstanding Federal Test Method Standard No. 141 (Method 6061) 500-hr salt spray test.
- Air-cooled condenser coils are pressure tested and the outdoor unit is leak tested.
- Unit constructed in ISO9001 approved facility.

Delivery, Storage, and Handling

- Unit will be shipped as single package only and is stored and handled per unit manufacturer's recommendations.

Warranty (for inclusion by specifying engineer)

- U.S. and Canada only.

PRODUCTS

Equipment

- Factory assembled, single piece, air-cooled heat pump unit. Contained within the unit enclosure is all factory wiring, piping, controls, compressor, refrigerant charge Puron® (R-410A), and special features required prior to field start-up.

Unit Cabinet

- Unit cabinet will be constructed of galvanized steel, bonderized, and coated with a powder coat paint.

Fans

- Condenser fan will be direct-drive propeller type, discharging air upward.
- Condenser fan motors will be totally enclosed, 1-phase type with class B insulation and permanently lubricated bearings.
- Shafts will be corrosion resistant.
- Fan blades will be statically and dynamically balanced.
- Condenser fan openings will be equipped with steel wire safety guards.

Compressor

- Compressor will be hermetically sealed.
- Compressor will be mounted on rubber vibration isolators.

Condenser Coil

- Condenser coil will be air cooled.
- Coil will be constructed of aluminum fins mechanically bonded to copper tubes which are then cleaned, dehydrated, and sealed.

Refrigeration Components

- Refrigeration circuit components will include liquid-line shutoff valve with sweat connections, vapor-line shutoff valve with sweat connections, system charge of Puron® (R-410A) refrigerant, POE compressor oil, accumulator, and reversing valve.

Operating Characteristics

- The capacity of the unit will meet or exceed _____ Btuh at a suction temperature of _____ °F/°C. The power consumption at full load will not exceed _____ kW.
- Combination of the unit and the evaporator or fan coil unit will have a total net cooling capacity of _____ Btuh or greater at conditions of _____ CFM entering air temperature at the evaporator at _____ °F wet bulb and _____ °F/°C dry bulb, and air entering the unit at _____ °F/°C.
- The system will have a SEER of _____ Btuh/watt or greater at DOE conditions.

Electrical Requirements

- Nominal unit electrical characteristics will be _____ v, single phase, 60 hz. The unit will be capable of satisfactory operation within voltage limits of _____ v to _____ v.
- Unit electrical power will be single point connection.
- Control circuit will be 24v.

Special Features

- Refer to section of this literature identifying accessories and descriptions for specific features and available enhancements.