

## MODEL 106/206-PR-S

### Pressure Reducing Valve with Downstream Surge Control Schematic A-0336D Installation, Operating and Maintenance Instructions

#### DESCRIPTION:

Model 106/206-PR-S is a pilot operated pressure reducing valve designed to automatically reduce a high inlet pressure into a lower outlet pressure. The valve will maintain a relatively steady downstream pressure regardless of fluctuations in the supply pressure or flow rate.

The downstream surge control increases the closing speed of the valve to help the valve maintain control when the demand is reduced suddenly.

Unless otherwise specified, the valve will be assembled for service temperatures to 180°F (60°C). Higher temperature ratings are available - consult SINGER VALVE for details.

#### DESCRIPTION OF OPERATION:

Main Valve (1) is normally open when pressure is applied to the valve inlet. When the same pressure is applied to the bonnet, the valve closes tight. Refer to 106/206-PG 'Description of Operation'. By controlling the pressure in the bonnet, the Main Valve can be made to open fully, close tight or open partially.

The bonnet pressure (and therefore the position of the Main Valve) is controlled by a pilot circuit consisting of Fixed Restriction (5) and Pressure Reducing Pilot (7).

When there is no demand (and the downstream pressure is at the setting of Pilot [7]), Pressure Reducing Pilot (7) is closed. Pressure from the inlet side of the Main Valve is directed to the bonnet through Fixed Restriction (5) and Flow Stabilizer (4), if so equipped. Main Valve (1) closes. When flow is required, Pilot (7) senses a drop in the downstream pressure and opens. Flow through Pilot (7) is greater than flow through Fixed Restriction (5). Bonnet pressure is reduced and Main Valve (1) opens to supply the demand. Speed of opening is determined by the setting of Flow Stabilizer (4), if so equipped.

Under flowing conditions, Pilot (7) reacts to small changes in pressure to modulate the bonnet pressure (and valve position) as required to keep the downstream pressure constant. Note that the Main Valve position follows the position of Pilot (7). When Pilot (7) closes, the Main Valve closes. When Pilot (7) opens, the Main Valve opens.

Surge Pilot (9) senses the downstream pressure. If the downstream pressure rises above the setting of Pressure Reducing Pilot (7) and reaches the setting of Surge Pilot (9), Surge Pilot (9) opens to close the Main Valve rapidly.

#### INSTALLATION:

1. Refer to 106/206-PG "Installation".
2. Installation where there is loosely held piping and/or elbows close to the valve may cause the valve to pulsate.

#### ADJUSTING PROCEDURE:

1. Open Isolating Valve (8) and Isolating Valves (2) and (6) if so equipped.
2. Crack outlet stop valve and slowly open inlet stop valve wide.
3. Bleed air from Main Valve bonnet. See 106/206-PG 'INSTALLATION'.
4. Open outlet stop valve wide.
5. Set reduced (downstream) pressure by turning Pilot (7) adjusting screw:
  - To increase pressure, turn adjusting screw clockwise.
  - To reduce pressure, turn adjusting screw counterclockwise.
  - **NOTE THAT THERE MUST BE FLOW THROUGH THE VALVE WHEN PRESSURE IS ADJUSTED AND SURGE PILOT (9) MUST BE SET HIGHER THAN PRESSURE REDUCING PILOT (7).**
6. Turn the adjusting screw of Surge Pilot (9) counterclockwise until the downstream pressure just begins to drop and then turn the adjusting screw clockwise 1/4 turn.
7. **IF THE VALVE DOES NOT OPEN** (downstream pressure remains low), check the adjustment of Flow Stabilizer (4), if so equipped. See Model 26 instructions.
8. **IF THE VALVE BEGINS TO OSCILLATE OR HUNT:**
  - Bleed air from Main Valve bonnet. SEE 106/206-PG 'INSTALLATION'.
  - Adjust Flow Stabilizer (4), if so equipped.. See Model 26 Instructions.

#### SERVICE SUGGESTIONS:

In addition to service suggestions listed in the 106/206-PG instructions, we suggest the following:

##### IF THE VALVE FAILS TO CLOSE:

Close Isolating Valve (8). If the Main Valve closes, Pilot (7) is defective. If the Main Valve does not close, remove the pilot tubing between Pilot (7) and Flow Stabilizer (4). If there is no flow from Flow Stabilizer (4), upstream pilot piping is obstructed. Also check Strainer (3). Close Isolating Valve (2). Remove the copper tube between Strainer (3) and Flow Stabilizer (4), if so equipped. If there is flow from Flow Stabilizer (4), the diaphragm is ruptured. If there is no flow from Flow Stabilizer (4), open Isolating Valve (2) slowly. If there is no flow, Strainer (3) is plugged.

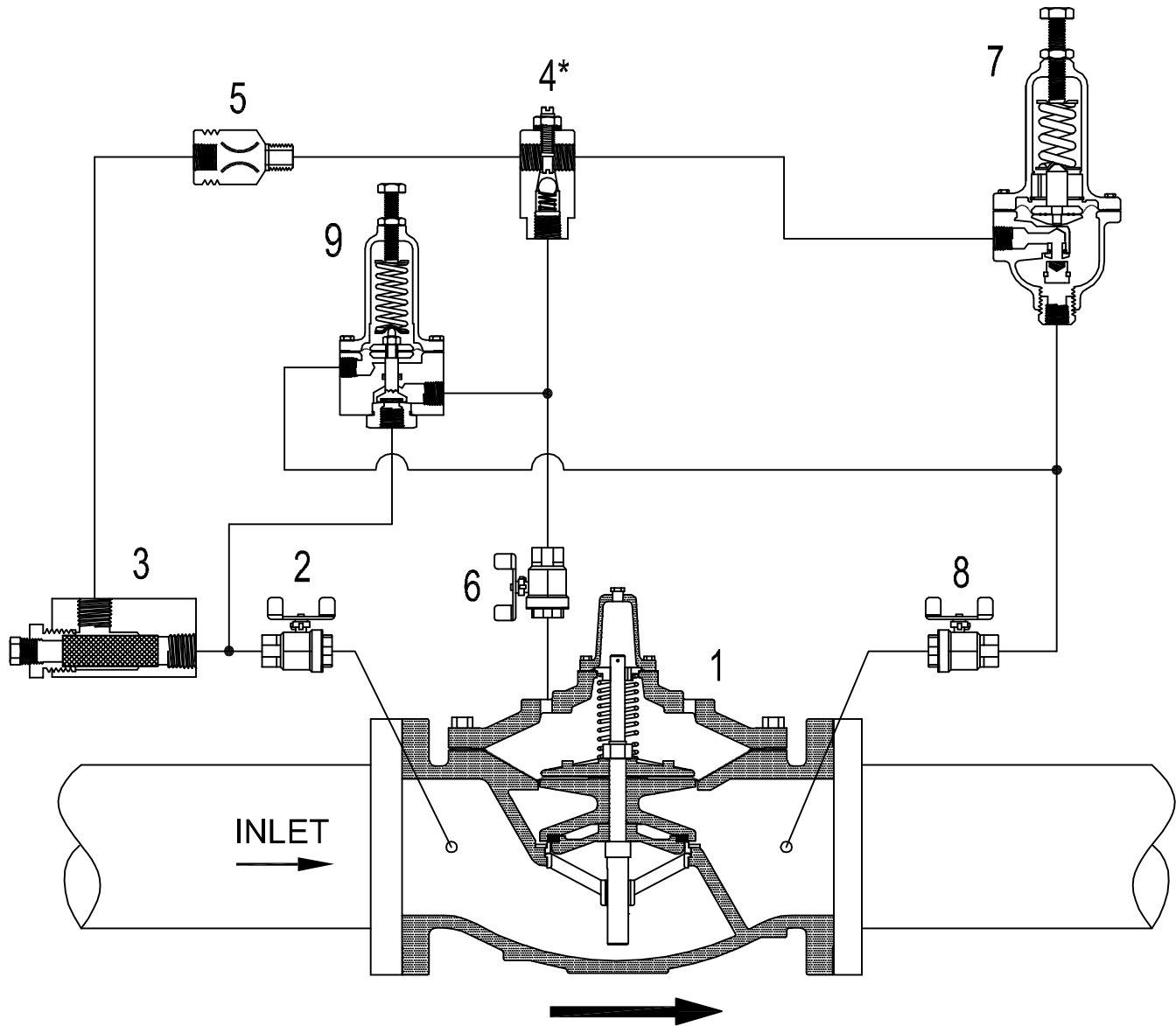

1. Main Valve - Model 106 or 206-PG.
2. Isolating Valve (standard on 4" and larger).
3. Strainer - J0098A (standard on 4" and larger).
4. Model 26 Flow Stabilizer / Opening Speed Control
  - \* Standard on FLAT (106 or 206) diaphragm valves.
  - \* Optional on ROLLING (S106 or S206) diaphragm valves.
5. Fixed Restriction.
6. Isolating Valve (standard on 4" and larger).
7. Pressure Reducing Pilot - Model 160.
8. Isolating Valve.
9. Surge Pilot - Model 81-RP.

### Pressure Reducing Valve with Downstream Surge Control.

\* Model 26 removed from 10" 106/12" 206 and larger April 25, 2008.  
 \* Added to Model 26 'Standard on FLAT, ... Optional on ROLLING...' April 15, 2010.



[www.singervalve.com](http://www.singervalve.com) 12850-87th Avenue, Surrey, B.C. V3W 3H9

Drawn By: **Scott Grover** Approved By: **Kari Oksanen**

Date: **April 9, 2003** Drawing: **A-0336D**

**Model 106 or 206-PR-S**