

MODELS 106-A-TYPE 1 / 206-A-TYPE 1 TWO-WAY FLOW ALTITUDE CONTROL VALVE

KEY FEATURES

- No overflows
- Superior repeatability
- Positive shut-off
- Easily serviceable at ground level

PRODUCT OVERVIEW

The 106-A-Type 1 and 206-A-Type 1 altitude control valves are based on the 106-PG or 206-PG main valve and are ideal for maintaining a preset maximum water level.

The valve functions as a two position control valve, either fully open or fully closed. The Type 1 allows normal forward flow to fill the reservoir to the maximum level and then closes drip-tight at the set-point. It opens to allow reverse flow through the valve when the supply pressure drops a fixed amount below the reservoir head. When a higher supply pressure is restored, the Type 1 valve will then allow normal forward flow to refill the tank to the maximum level.



TYPICAL APPLICATION

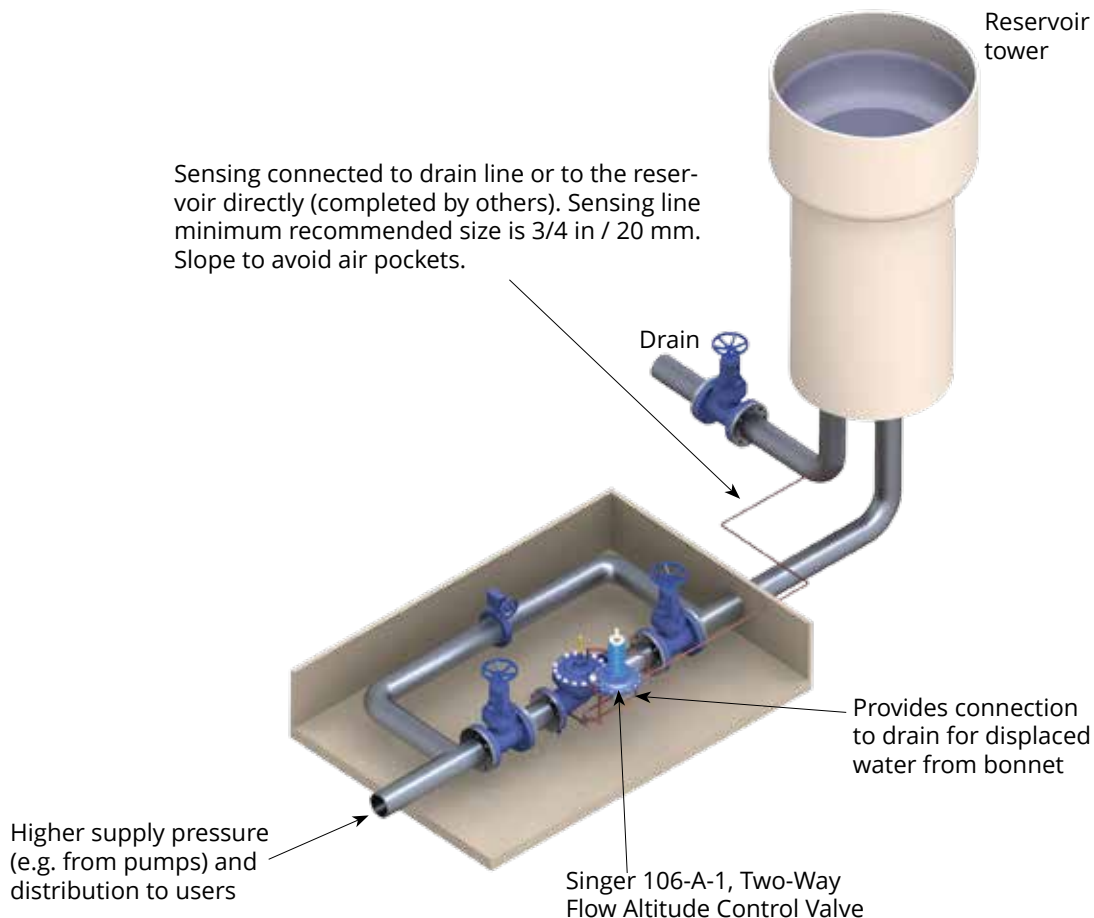

SCHEMATIC DRAWING

1. Main Valve - 106-PG or 206-PG - with X107 position indicator
2. Isolation Valve
3. Strainer - 40 mesh stainless steel screen
4. Model 10 Check Valve
5. Closing Speed Control
6. Model 12 Check Valve
7. Model 301-4 Altitude Pilot
8. Altitude Gauge
9. Fixed Restriction - 1/8 in / 3.2 mm, 1/16 in / 1.58 mm
10. Union
11. Isolation Valve
12. Connection to Reservoir - complete in field
13. Model 12 Check Valve
14. Isolation Valve

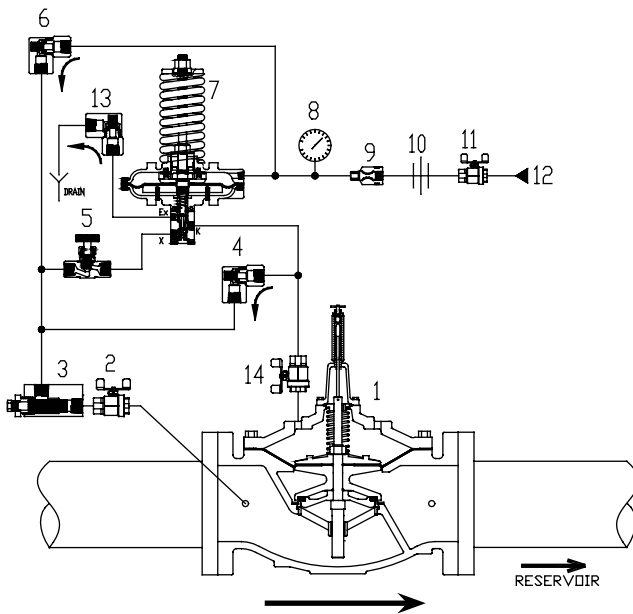

Schematic A-0412D

STANDARD MATERIALS

Standard materials for pilot system components are:

- Ductile Iron
- Stainless Steel
- Brass
- Copper

SELECTION SUMMARY

1. Generally select line size to minimize losses during normal forward flow.
2. Use the performance curves and sizing bulletin to determine the pressure drop across the valve.
3. Limit maximum continuous flow velocity to 20 ft/s / 6 m/s for 106 and 16 ft/s / 5 m/s for 206. Consult Singer Valve if higher flows are expected.
4. The pilot system exhausts to atmosphere, ensuring the valve opens fully; requires that the displaced volume of water be taken to drain with each opening.
5. Select pilot spring range: 4 to 20 ft / 1 to 6 m; 10 to 60 ft / 3 to 18 m; 40 to 125 ft / 12 to 38 m; 60 to 220 ft / 18 to 67 m.
6. There is a non-adjustable differential required between the reservoir head and the supply pressure in order for the valve to open. It ranges from 1 ft / 0.3 m to 3 ft / 0.90 m for the pilot spring ranges listed.

ORDERING INSTRUCTIONS

Refer to page 244 for the order form and ordering instructions.

Additionally, include the following information for this product:

1. Single chamber (106) or (206)
2. Pilot range

MODELS 106-A-TYPE 1 / 206-A-TYPE 1 TWO-WAY FLOW ALTITUDE CONTROL VALVE

106-A-Type 1	Flow Coefficient C_v (See 106-PG in Main Valve section for other valve data)			
Size (inches)	3 in	4 in	6 in	8 in
Size (mm)	80 mm	100 mm	150 mm	200 mm
C_v^1	110	200	460	800
K_v^2	26	47	110	190

106-A-Type 1	Flow Coefficient C_v (See 106-PG in Main Valve section for other valve data)						
Size (inches)	10 in	12 in	14 in	16 in	20 in	24 in	36 in
Size (mm)	250 mm	300 mm	350 mm	400 mm	500 mm	600 mm	900 mm
C_v^1	1300	2100	2575	3300	5100	7600	16340
K_v^2	310	500	610	780	1210	1800	3875

206-A-Type 1	Flow Coefficient C_v (See 206-PG in Main Valve section for other valve data)			
Size (inches)	3 in	4 in	6 in	8 in
Size (mm)	80 mm	100 mm	150 mm	200 mm
C_v^1	60	150	250	505
K_v^2	14	36	60	120

206-A-Type 1	Flow Coefficient C_v (See 206-PG in Main Valve section for other valve data)											
Size (inches)	10 in	12 in	16 in	18 in	20 in	24 x 16 in	24 x 20 in	28 in	30 in	32 in	36 in	40 in
Size (mm)	250 mm	300 mm	400 mm	450 mm	500 mm	600 x 400 mm	600 x 500 mm	700 mm	750 mm	800 mm	900 mm	1000 mm
C_v^1	985	1550	2200	3300	3400	3500	5100	7800	7800	7900	8000	18000
K_v^2	230	370	520	780	810	830	1210	1850	1850	1870	1900	4265

* C_v = USGPM at 1 psi pressure drop

** K_v = L / s at 1 bar pressure drop

$$(Q=C_v\sqrt{\Delta P})$$

Note: based on fully open valve