



Features – Standard Models

Nominal best efficiency point – 1,250 gallons per minute @ 115 feet TDH (water)			
Engine horsepower		110 continuous HP	
Sludge pump		SRS Crisafulli 4-inch J-Series	
Pump/dredge discharge diameter		4x6 inches	
Spherical solids passage – maximum		2.93 inches	
Propeller		Low speed, high thrust	
Dredging depth		10 feet	
Propulsion type		Four-stroke outboard	
Pontoons		Foam-filled aluminum	
Draft		17 inches (432 mm)	
Freeboard		11 inches (279 mm)	
Walkway		Non-skid surface	
Lighting		Sealed beam headlights	
Operator’s cab		Adjustable seat and steering; sunshade covering	
Color		Gray standard, white trim	
Electrical power		Dual 12V DC independent circuits	
Diesel fuel capacity		58 gallons (219.6 liters)	
Gasoline fuel capacity		24 gallons (90.85 liters)	
Diesel fuel consumption		5.8 gallons per hour	
Cutterhead width	8.5 feet (2.59 m)	Length (overall)	24.5 feet (7.47 m)
Cutterhead drive	Dual	Length (pontoons)	20 feet (6.01 m)
Cutterhead rotation	Bi-rotational variable speed	Width	8 feet (2.44 m)
Cutterhead torque	11,000 inch/pounds	Weight (maximum)	6,550 pounds (2,971 Kg)
Cutting teeth	Hardened steel Cobra	Height (maximum)	6.5 feet (1.98 m) w/o sunshade 9.5 feet (3.3 m) with sunshade
Controls		Instrumentation	
Gas and diesel engine speed • Depth Propulsion speed – Forward/N/Reverse Cutterhead – Forward/N/Reverse • Gas and diesel start key Sludge pump speed – Forward/N/Reverse Traverse winch – Forward/Reverse		Outboard tachometer • Diesel engine temperature Hydraulic pressures • Outboard warning alarm Diesel engine tachometer • Diesel engine oil pressure Diesel engine volt meter • Hydraulic oil level and temperature Filter pressure drop indicator	
Options			
Hardened pump surfaces for added abrasion resistance • Ultrasonic flow meter Mechanical depth indicator • Operators cab - fully enclosed with heat and A/C Liner protection system – cage, wheels, or both • Sidecasting nozzle • Increased outboard horsepower - 50 or 60 HP			

Rotomite SD-110

The world’s lightest, high production, shallow draft manned dredge.

Silt and Sediment Control even in the shallows.

- ☞ You can dredge in 17 inches of water and depths of up to 10 feet!
- ☞ Lightweight & Maneuverable – You can dredge difficult areas: under docks, along shorelines, and around water intakes.
- ☞ Economical, effective sediment control – You can control silt and sediment.
- ☞ Portability, transportable anywhere in the U.S. on a regular deck-over trailer.



Optimum performance

Operating at a nominal Best Efficiency Point of 1,250 GPM at 115 feet Total Dynamic Head in clean water, the SD-110 delivers amazing productivity in a compact, lightweight design. Capable of producing flows of up 1,750 GPM and heads to 65 feet Total Dynamic Head, you can absolutely count on solids production up to 85 cubic yards/hour.

SD-110’s light-weight aluminum super-structure, 6,500 lbs, combined with a compact platform means the dredge is easy to lift and transport.

Unmatched versatility

Do you need to dredge in the shallows? The SD-110 can dredge under a dock and maneuver between pilings. The SD-110 can clean every foot of a canal 10 feet deep and work around water intake structures or between aerators. Originally designed with a sidecasting nozzle to deposit the dredged slurry on the Missouri River shoreline, we also designed the SD-110 dredge to connect to floating discharge lines. Just connect the floating discharge line to carry the slurry away or ask Crisafulli for a sidecasting nozzle so you can deposit the slurry on the shoreline.

Customers have been saying “Crisafulli is the best” for 40 years. Crisafulli Pumps, Dredges, and Power Units are customizable - Choose special materials for construction, power source, bearings and suction.

Each Crisafulli Pump has a Crisafulli Impeller inside - your assurance of quality, performance, reliability and long useful life.

The wide range of performance and application capabilities of the rugged, reliable Crisafulli Pump, Dredge, and Power Unit product line, each model of which can be customized to our customer's special requirements, provides our customers with what we call "The Crisafulli Advantage."

Visit us on the web today at www.crisafullipumps.com
or call us toll free: 1-800-442-7867



Pumps • Dredges • Power Units – Custom or Standard
Manufacturers of reliable Crisafulli products supported by superior service
SRS Crisafulli, Inc. • 1610 Crisafulli Drive • P.O. Box 1051 • Glendive, MT 59330 • USA
Phone: 406-365-3393 • Toll free: 800-442-7867 • Fax: 406-365-8088 • Email: srsc@crisafulli.com



Pumps • Dredges • Power Units – Custom or Standard
Manufacturers of reliable Crisafulli products supported by superior service

 The stylized pump impeller symbolizes Crisafulli's focus on efficient movement of fluids, sludges and slurries.
www.crisafullipumps.com

SRS Crisafulli

RELIABLE PRODUCTS – SUPERIOR SERVICE

– THE ROTOMITE™ SD-110

Provides customers with the BEST VALUE.

Propulsion. The SD-110's top speed is 10 mph in still water. The 50 HP four-stroke outboard motor enables the SD-110 to maneuver in tight spots, like boat docks. The hinged motor allows it to be raised above water level.



Discharge. The SD-110 can be equipped with two styles of discharge: slurry flow can be directed through a floating pipeline to a location on shore, or conveyed via a sidecasting discharge nozzle at the rear of the barge, enabling the dredge operator to direct the slurry stream from 32-80 feet onto a river bank. 50-70 cubic yards of solids can be moved an hour through the nozzle.

Electrical and fuel systems. The outboard motor for propulsion and the 110 HP diesel engine to power the pump and the auger have independent 12V DC systems. The redundant electrical system provides the operator the luxury of an extra battery onboard in case of an unforeseen power loss. The diesel engine includes a marine-duty gauge package and an emergency (high temperature/low oil pressure) shutdown system.



Portability. Weighing only 6,500 lbs, with an aluminum super structure, four lifting eyes, and measuring only 24.5 x 8 feet, the SD-110 can be lifted by almost any crane, and is transportable anywhere in the U.S. without special permitting on a regular deck-over trailer.

Fuel capacity. 58-gallon, 10-hour diesel fuel capacity (dual tanks with switchover); 24-gallon gas fuel tank for outboard motor.

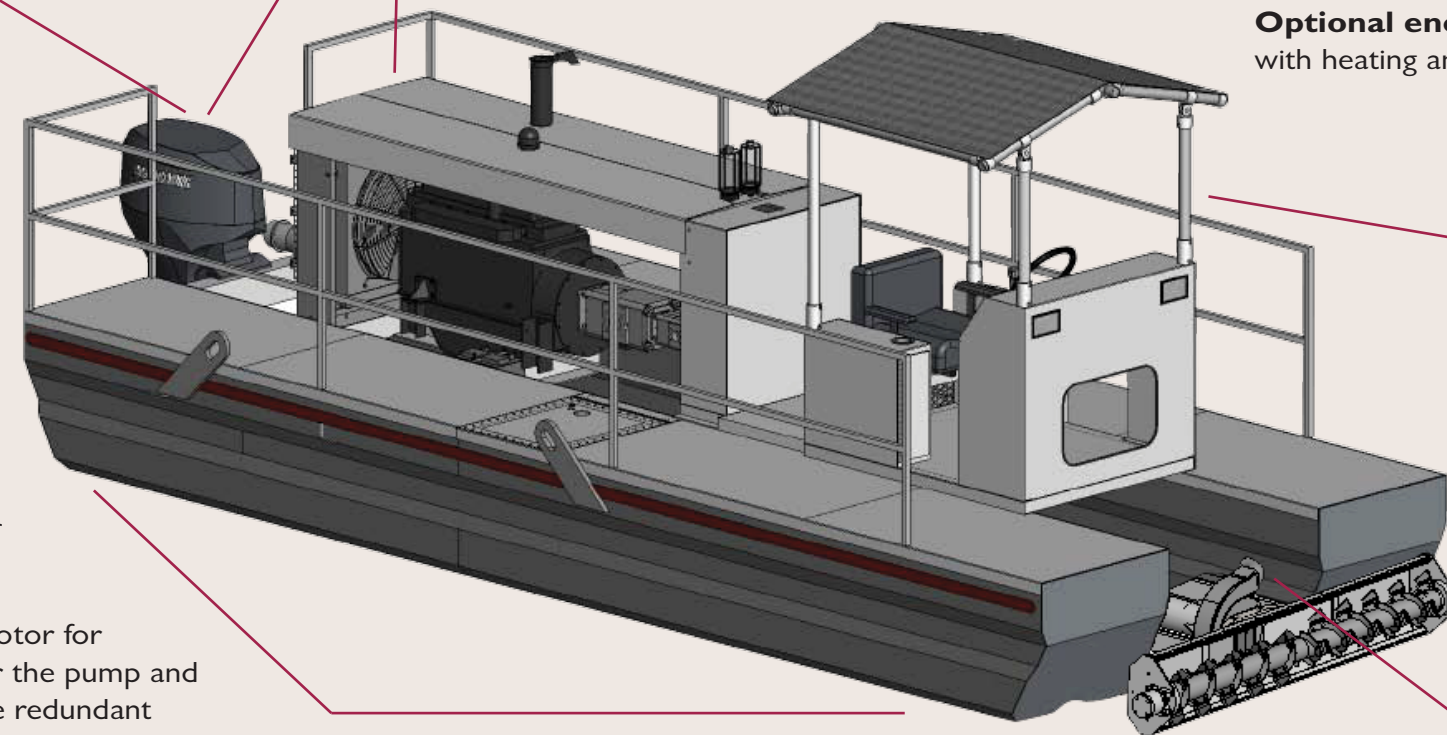

Pontoons are 20 feet long, aluminum, urethane-foam filled, internally reinforced, with integral lifting eyes. The pontoons are divided into 5 sections that each have a rub strip on the leading and bottom edges for safety.

102-inch wide cutterhead – 10-foot dredge depth.

The Rotomite SD-110's 102-inch wide cutterhead provides 8.5 feet of actual dredging width and 10 feet of dredge depth. The Crisafulli Cobra cutterhead/auger assembly is directly mounted to the pump intake. The dual hydraulic auger drive motors create 11,000 in./lbs. of total digging torque.



Optional enclosed cab comes with heating and air conditioning.



Operator station. Helm and operational controls, aluminum frame construction, canvas canopy over operator station, steering wheel and hydraulic control levers, and a foam-cushioned vinyl fabric-backed covered operator's seat.

Easy to operate. Designed with the operator in mind, the dredge has on-board storage in the operator's station and a 12V DC power point for the operator's personal items – i.e. cell phone – with four additional 12V DC circuits, an adjustable helm, and a built in cup holder. A walkway behind the operator's station enables safe, easy operator movement from one side of the dredge to the other.



Sludge pump by Crisafulli.

4-inch J-Series, submersible, variable speed, hydraulic dredge pump with dual mechanical seal bearing frame. The SD-110 is also available with a Chrome Carbide volute Crisafulli 4-inch J-Series pump for additional abrasion resistance.