

Hughes 9250: Land-Vehicular Satellite Modem



The Hughes 9250 Broadband Satellite IP Terminal and WLAN Access Point is your gateway to mobile communications. It allows you to send and receive IP packet data via Ethernet and WLAN interfaces over the Inmarsat BGAN satellite network in a land-vehicular application. In parallel with the packet data services, the same terminal supports a circuit switched voice call or a 64kbps ISDN data call.

The main features are:

- Fully autonomous tracking antenna acquires and tracks the BGAN satellite signal while on the move
- Easy antenna installation (magnetic mount) on vehicle roof
- Includes antenna control unit and all cables and power supplies for vehicular installation
- Up to 464kbps shared data rate and 128kbps streaming IP data rate¹.

Other features are:

- ISDN bearer capabilities: Speech (4kbps), 3.1k Audio (64kbps), ISDN data (64kbps)
- Allows simultaneous use of all interfaces (Ethernet, ISDN and WLAN)
- WLAN access point
- Multi-user capability (up to 11 simultaneous sessions)
- Selectable Quality of Service (32kbps, 64kbps or 128kbps)

Package Contents:

- Tracking Antenna including interface box, cable set and magnetic feet for roof mount.
- Broadband Satellite IP Terminal and WLAN Access Point
- Rechargeable lithium ion battery pack
- DC to DC power supply – powers the satellite modem as well as the tracking antenna.
- Ethernet cable
- ISDN cable
- User guide (PDF file on CD)
- Installation CD

¹. Best efforts performance under moving conditions depending on obstruction of satellite signal. Performance is limited by the BGAN system design: Signal outages of more than 3 seconds will cause circuit switched calls to be dropped and packet switched sessions being interrupted. May require user intervention to reactivate connections for longer outage durations.

Technical Specifications:

	Terminal	Antenna
Weight:	2.8 Kg (terminal with battery)	5.5 Kg
Dimensions:	275 mm x 345 mm x 50 mm	Ø477 mm x 153 mm
Humidity:	95% RH at +40° C	95% RH at +40° C
Temperature:	-25° C to +60° C operating -25° C to +60° C storage (w/ battery)	-25° C to +55° C operating -25° C to +80° C survival
Wind:	N/A	125 mph (200 km/h) Exception for Magnetic Mount: 100 mph (160 km/h)
Water & Dust:		IP-56 standard
Ice:		25 mm non-operational
Vehicle Motions:		Turning Rate: 40°/s Turning acceleration 50°/s ²
Power:	Idle: 20 W Max: 100 W (when transmitting)	

Block Diagram

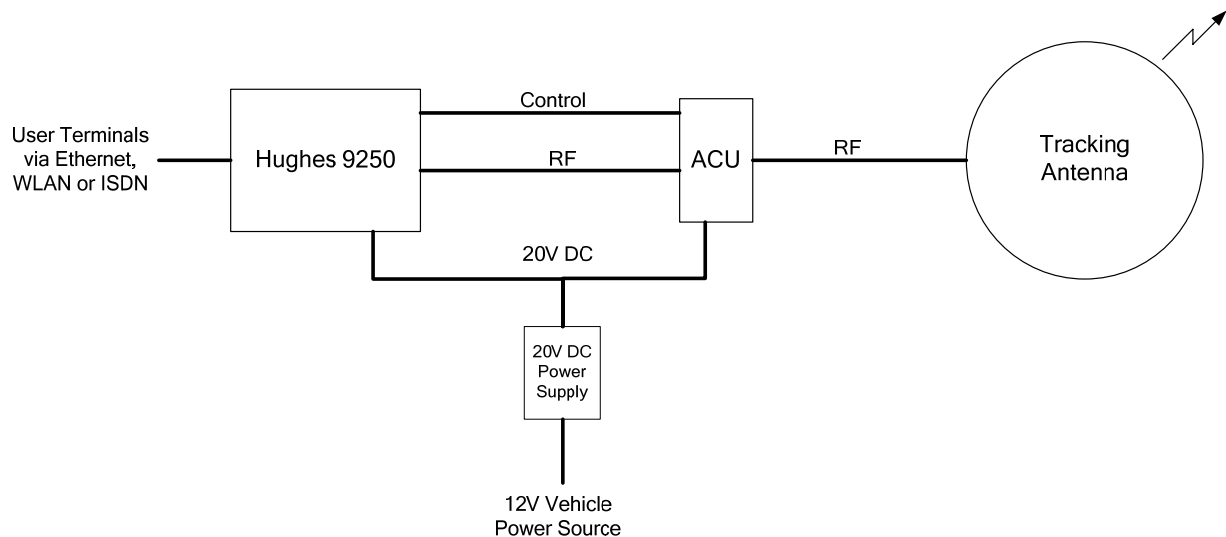

The Hughes terminal controls the tracking antenna through the Antenna Control Unit (ACU). This small interface box modulates control signals from the terminal onto the RF link between the terminal and the antenna. All components are powered by a single power supply that plugs into a vehicular 12V power source.