

Transient Heat Transfer Analysis of High Speed Train Disc Brake Systems

Satoshi Fujii, Makoto Saito, Ph.D.

CAE & Materials Department, Nabtesco Corporation, Japan

As the maximum speed of bullet trains continues to increase, overheating and thermal deformation/stress on brake systems are going to be critical for emergency stops. Precise prediction of the maximum temperature is needed for the design of brake systems, especially for both discs and linings, where how to handle the high speed spinning of discs is the point of the heat/structure coupled analyses.

Abaqus provides couple of potential methods but each one had critical shortcomings. The authors investigated the feasibility of a new method; Abaqus/Explicit using 'rigid bodies with temperature degrees of freedom' for fully coupled thermal analysis. Temperature of both discs and linings was successfully analyzed over the whole time span of an emergency braking event with practical computation time.

Full-scale experiments were carried out to verify the analysis results related to the temperature of both discs and linings, and the results showed good agreement.

Keywords: Heat Transfer, Dynamic Explicit, Train, Disc Brake

1. Introduction

Overheating and thermal deformation of disc brake systems during emergency braking are becoming critical as the maximum speed of bullet trains increases. To design the brake systems, precise prediction of the maximum temperature is needed, especially for discs and linings.

Frictional heat generated during a braking event is conducted through both discs and linings and cooled by the air around them. Because the amount of heat that is transferred to the discs may depend on their design and the train speed, it is difficult to determine beforehand and analyze discs and linings separately.

In this paper, heat transfer analysis of a brake system was carried out to analyze transient temperature changes.

2. Analytical methods

2.1 Components for analysis

Disc brake systems mainly consist of the components represented in Figure 1: two brake discs, brake linings, a wheel, and a caliper assembly. The wheel and the two discs on both sides of the wheel are fastened together and rotate at 36 Hz when the train is running at 350km/h.

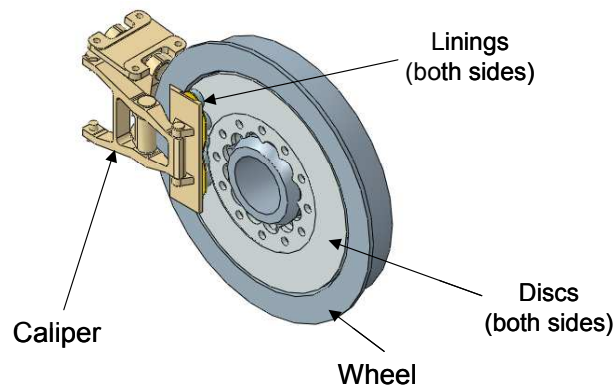

Figure 1. Disc brake components

2.2 Existing methods

These are methods introduced in the “Abaqus Example Problems Manual”.

(1) Axisymmetric model or periodic boundary condition

(2) Fully coupled heat-structure analysis of Abaqus/Standard

(3) Sequentially coupled thermal-mechanical analysis with an Eulerian approach

The axisymmetric or periodic model was not applicable for this case because the linings and discs cannot be analyzed simultaneously. If the distribution rate of the friction heat is already known, these methods are very economical. Fully coupled heat-structure analysis of Abaqus/Standard required increments of time that were too short because of the high rotation speed of the discs and the wheel.

So the Eulerian approach that utilized forced convection elements of Abaqus/Standard was examined and this method was also found to have a problem with computation time caused by high rotational velocity.

Forced convection/diffusion elements (DCC3D8), which are used in the Eulerian approach, is the element for thermal analysis that can represent prescribed material flow. The Courant Number C and Peclet number γ relate to computational stability and precision. C must be less than 1 and γ must be less than 1000 in general. In this case, time increments became too short to analyze the entire braking procedure if those conditions were both fulfilled.

2.3 Thermal analysis method using Abaqus/Explicit

From the above-mentioned studies, the short time increments caused by high rotation speed of discs made analysis impossible in practical computational time. Abaqus/Explicit, which requires very short computational time for each increment, might be able to solve this problem. Ordinary fully coupled heat structure analysis was tried but the stable time increment for the explicit integration was unacceptably small.

So we assumed that the contact conditions were not changing during the braking event because of the wear on the linings and that all parts were made rigid bodies for the deformation degrees of freedom. Because all elements had only temperature degrees of freedom, the stable time increment increased by two digits and the problem could be analyzed in practical computation time.

2.3.1 Disc rotation speed and heat generation

All parts in this analysis were rigid bodies. Prescribed angular velocity that was calculated from the deceleration specified by the customer was applied to the wheel axis as shown in Figure 2.

Necessary braking force was derived from the deceleration spec and frictional heat was also calculated from the force and the velocity. The heat was applied on the surfaces of the linings.

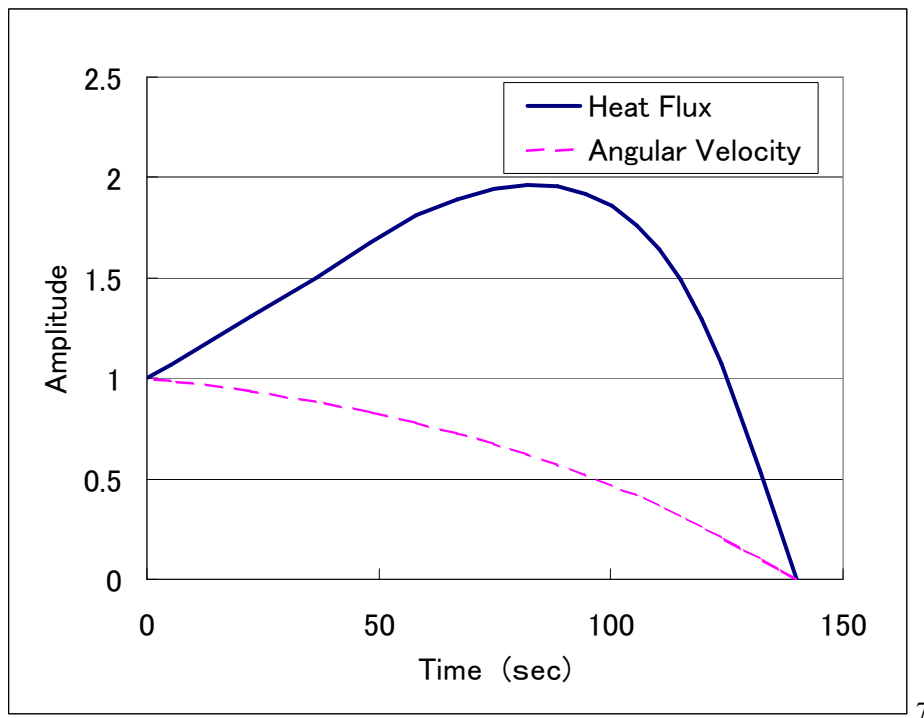

Figure 2. An example of amplitude of angular velocity and heat flux

2.3.2 Heat transfer on the surfaces

Conductive heat transfer between the parts was considered using thermal contact properties. Abaqus/Explicit can handle heat generated due to frictional sliding but in this problem we apply

heat flux directly instead of using this functionality because the penetrations were excessive between the rigid surfaces of the discs and the linings when that functionality was used.

3. Measurement method

Nabtesco has brake testing facilities that can reproduce up to 480km/h train speeds (See Figure. 3.) The emergency brake patterns from various initial speeds were tested using these facilities. Temperatures of discs and linings were measured by thermocouples and surface temperature contours were taken by thermal video. Measurements were repeated twice for each initial speed condition.



Figure 3. Brake test stand

4. Results and discussion

4.1 Measurements

Figure 4 shows the results of the measurements. The results were evaluated by the temperature difference between initial temperature and individual measurement temperatures.

Difference between the first measurement and the second were 20 K at most. This difference could be due to the wear and adhesion of the linings. Because the temperatures were changeable depending on the operating condition, the analysis results expected to be between these differences.

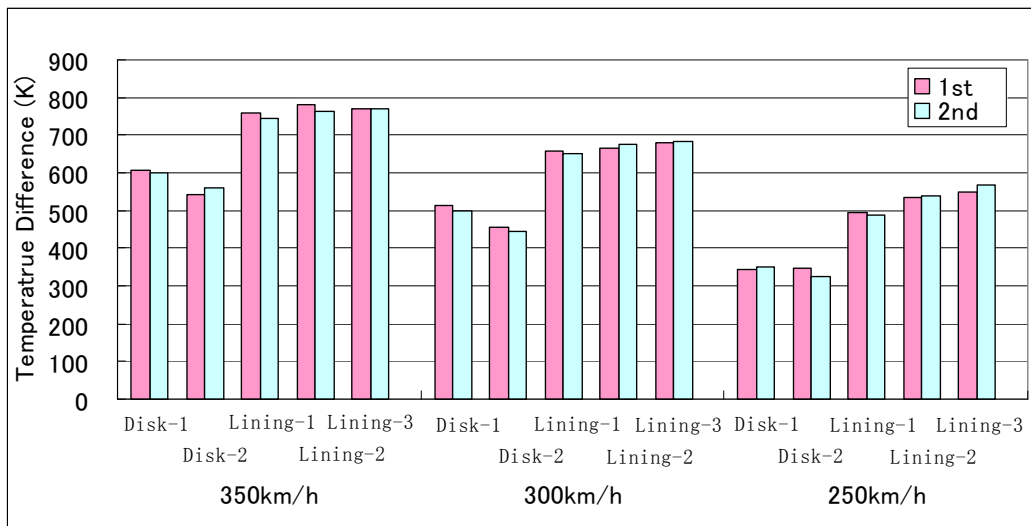

Figure 4. The results of the measurements

4.2 Temperature on surfaces

Temperature contours of the measurements and the analysis results are shown in Figure 5. In both figures, the temperature distributions were concentric and increased with time. The temperature distributions of analysis were in good agreement with the measurements besides the low temperature regions, where the measured values of thermal video were influenced by the reflection from high temperature regions.

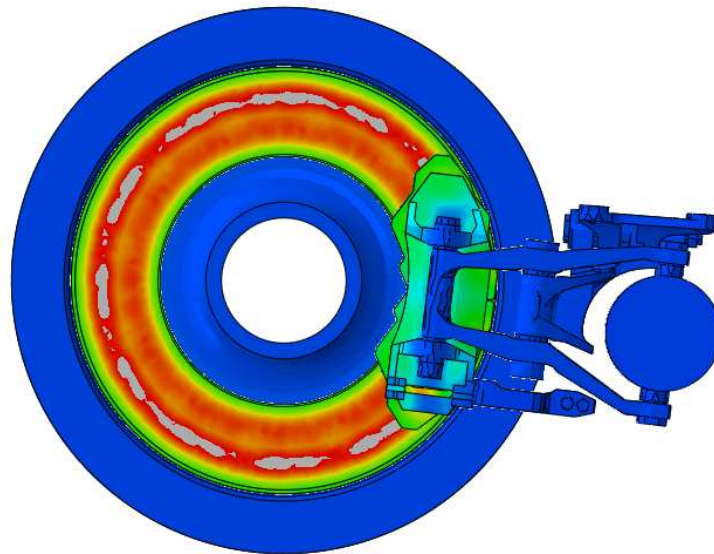
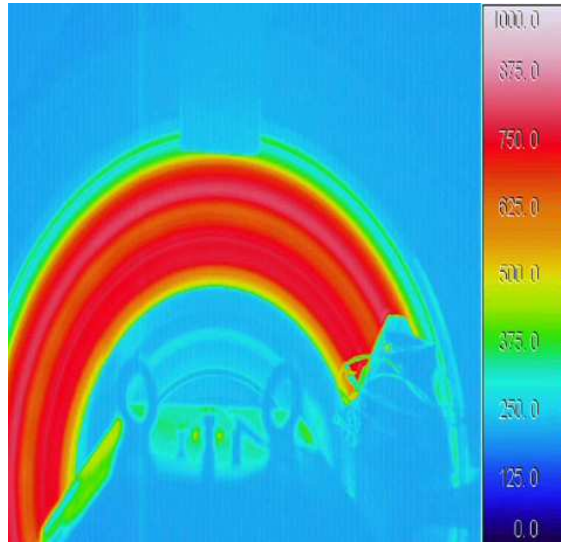

Figure 5. Temperature contours of experiment and analysis

4.3 Comparison of temperature between analysis and measurements

The results of the analyses and the measurements are shown in Table 1. As the largest error was 10%, the analysis results were in good agreement with the measurements.

Time series plots of the analyses and measurement results are shown in Figure 6-9.

- Discs (Figures 6, 7)

While Temperatures of Disk-1 and Disk-2 are almost identical in the analyses, the measurements temperatures of Disk-1, which is on inside, are higher by 50K than the temperatures of Disk-2, which is on outside. This difference seemed to come from the measurements environment such as airflow around the wheel.

- Linings (Figures 8, 9)

The plots of analyses results are smooth but there are some fluctuations in the measurements of the linings. These fluctuations are possibly caused by an imbalance in braking force, wears on the linings and thermal deformation of the discs.

- Overall results

Analysis results of overall time series change and maximum temperature agreed with the measurements results, besides the analysis could not simulate the fluctuations mentioned above.

Table 1. Temperature differences of the analysis and the measurements

			Speed (km/h)		
			350	300	250
Temperature Difference (K)	Disk1	Analysis	566	455	331
		Measurement	604	506	347
		Error	6%	10%	5%
	Disk2	Analysis	566	455	331
		Measurement	553	448	337
		Error	2%	1%	2%
	Lining1	Analysis	750	624	495
		Measurement	752	655	491
		Error	0%	5%	1%
	Lining2	Analysis	830	697	554
		Measurement	772	670	537
		Error	7%	4%	3%
	Lining3	Analysis	827	696	558
		Measurement	771	681	559
		Error	7%	2%	0%

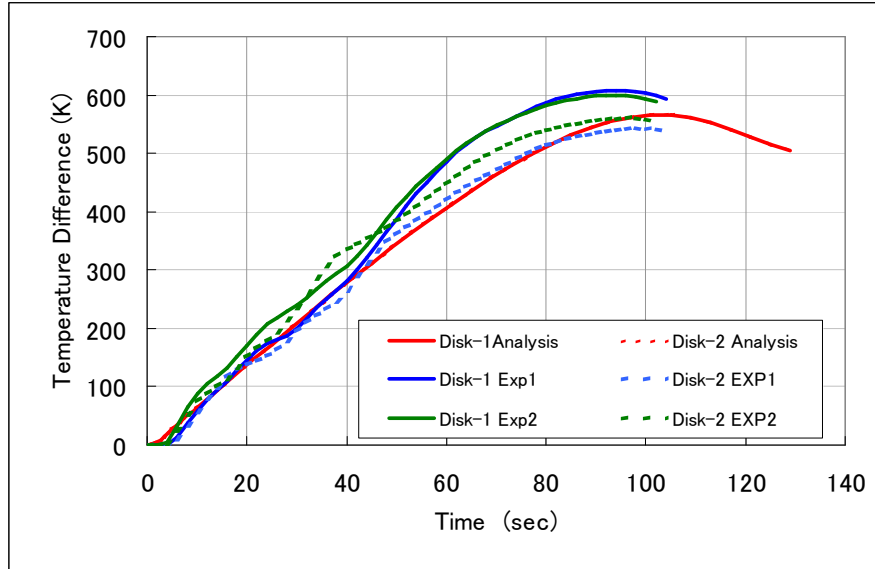

Figure 6. Temperatures of the discs (350km/h)

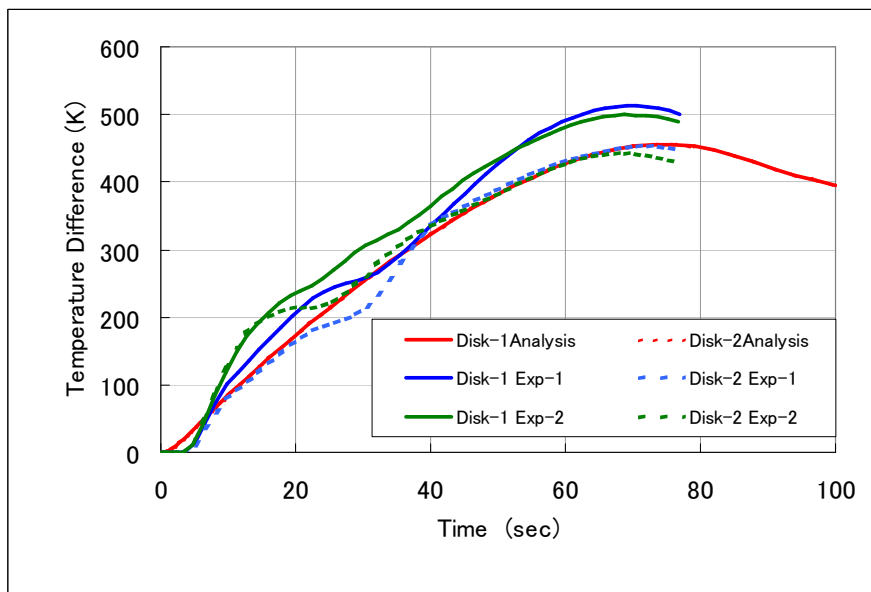

Figure 7. Temperatures of the discs (300km/h)

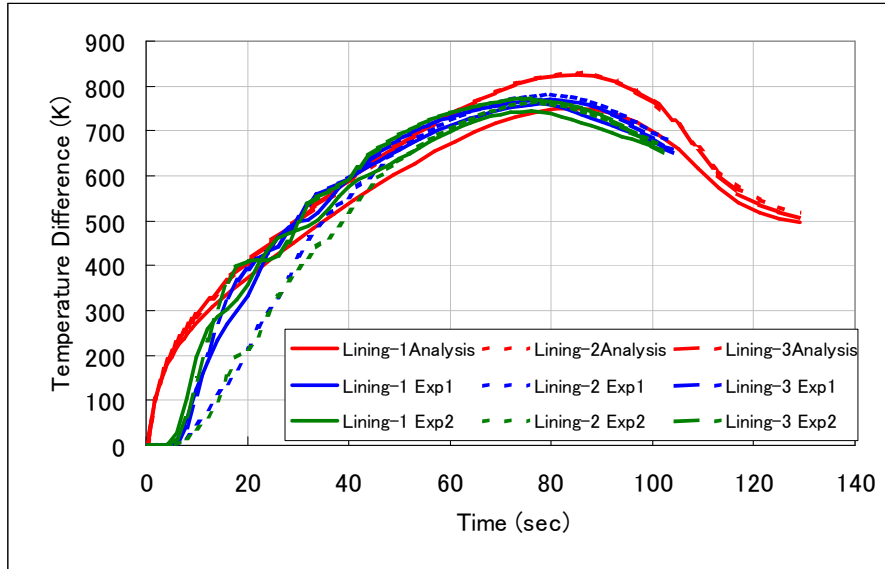

Figure 8. Temperatures of the linings (350km/h)

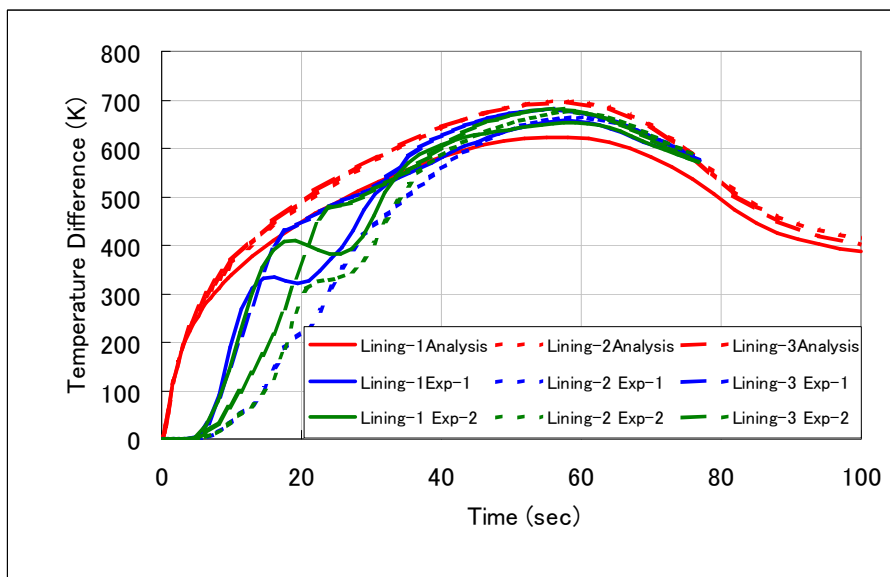

Figure 9. Temperatures of the linings (300km/h)

5. Conclusion

Fully coupled heat structure analysis of Abaqus/Explicit was tried to analyze the temperature of high speed rotating brake discs but the time increments turned out to be too small to analyze them in practical computational time. The rigid body constraint for the deformation degrees of freedom was introduced to solve this problem. The whole procedures of emergency braking were analyzed in practical computational time while maintaining the error of max temperature within 10%.