

On the application of ABAQUS for the evaluation of the structural integrity of railway vehicles

Alois Starlinger

Stadler Rail, Altenrhein, Switzerland

Abstract: Stadler Rail, an emerging European railway manufacturer, has been using ABAQUS for the structural evaluation of car body shells and bogie frames since 2003. The finite element models derived for quasi-static analyses of the primary load carrying structures can be directly used for explicit analyses of the crashworthiness behavior. Standards like EN15227 or the FRA waiver regulations in the RSAC ETF I report of FRA prescribe special collision scenarios for which the survival zone of the passengers and the engineer have to be proven. Comparisons between explicit analysis results and dynamic testing have shown that the crash behavior of the structures has been successfully captured.

Keywords: Crashworthiness, Design Optimization, Dynamics, Elasticity, Experimental Verification, Failure, Inertia Relief, Mechanisms, Minimum-Weight Structures, Multi-Body Dynamics, Occupant Modeling, Optimization, Plasticity, Post processing, Railcar, Residual Stress, Safety, Shell Structures, Substructures, Suspension, Visualization, Welding.

1. Introduction

Stadler Rail has developed a new regional train, the Stadler GTW, for Capital Metro, Austin, and for Denton County Transportation Authority, Texas. These DMU vehicles are compliant with the requests of EN15227, the European standard for crashworthiness of railway vehicles, and of EN12663-1, category P-II.

For the GTW DMU end car a suitable crash concept including an automatic coupler, a pair of energy absorption modules (in two stages) and a protective frame has been developed in order to fulfill the requirements of the EN15227. Explicit numerical analyses and dynamic testing have shown that the requirements of EN15227 are met. In the course of the US homologation process of this vehicle US specific requirements have been imposed: These requirements are outlined in the waiver guideline 'Technical Criteria and Procedures for Evaluating the Crashworthiness and Occupant Protection Performance of Alternatively-Designed Passenger Rail Equipment for Use in Tier I Service', DRAFT RSAC REPORT - 6-11-10, issued by the FRA established by the engineering task force for TIER I (ETF) by the Railroad Safety Advisory Committee (RSAC) of the Federal Railroad Administration (FRA).

In the following the performance of the crash energy management structure of the GTW DMU is described and demonstrated by different investigations.

2. GTW DMU – Crash Energy Management (CEM)

The crash energy management (CEM) structure of the Stadler GTW DMU is generally based on the following concept:

- Energy absorption by controlled plastic deformation
- Design based on welded rolled aluminum sheets and longitudinal aluminum extrusions
- Optimized cross section geometry of energy absorption structures
- Suitable triggering methods
- Bolted fixation of the welded end plates to the car body structure.

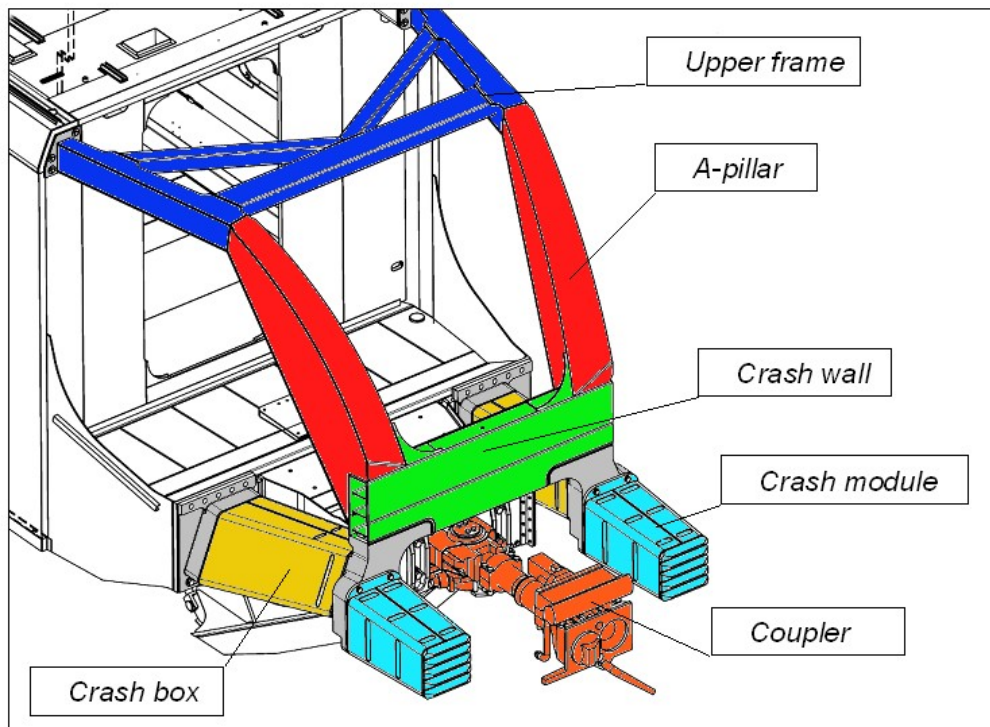

Figure 1. Crash concept of the STADLER GTW DMU

The main components of the GTW CEM structure are:

- Coupler with energy absorption and release function
- Pair of energy absorption elements (crash modules) with interlocking feature
- Reinforced upper frame to protect the roof of the driver cabin from collapse

- Pair of vertical beams (A-pillar) and a rigid cabin front wall (crash wall) to protect the engineer in case of front impacts
- Pair of energy absorption elements (crash boxes) placed between the crash wall and the car body.

The design of the crash energy management (CEM) structure is based on welded aluminum sheets of the alloy EN AW-5754 H111.

2.1 EUROPEAN REQUIREMENTS ON CRASHWORTHINESS AS DEFINED IN EN15227

Based on EN15227 the following measures are to be employed to increase the passive safety for the occupant in the event of an accident:

- Resisting overriding
- Absorbing collision energy
- Preserving survival space
- Limiting the deceleration rate
- Resisting intrusion into the survival space
- Minimizing the consequences of hitting a track obstruction.

According to the standard EN15227, the following scenarios have been verified in a dynamic explicit finite element simulation:

- Collision Scenario 1: a front end impact between two identical units at 36 kmph
- Collision Scenario 2: a front end impact into a buffered rail vehicle at 36 kmph
- Collision Scenario 3: train unit front end impact with a large deformable 15 ton obstacle (e.g., lorry on road crossing) at 110 kph.

The dynamic simulations of the EN15227 collision scenarios take into account the following non-linear effects:

- Large deformations
- Materials with plastic properties
- Contact conditions including friction properties
- Failure criteria for welds.

2.2 Results for Collision Scenario 3 of EN 15227:

The performance of the GTW DMU structure with respect to the requirements of EN 15227 has been shown by Starlinger et al., 2006. As a characteristic example the collision scenario 3 is highlighted here. Collision Scenario 3 defines a train unit front end impact with a large deformable 15 ton obstacle (e.g., lorry on road crossing), see figure 2. The material model of the large deformable obstacle has recently been optimized with respect to the limit curve defined in EN15227: An isotropic bilinear elastic-plastic material model with damage has been chosen for the material definition. The parameters have been optimized in Isight using the pointer method (optimization provided by Simulia Germany, Axel Reichert).

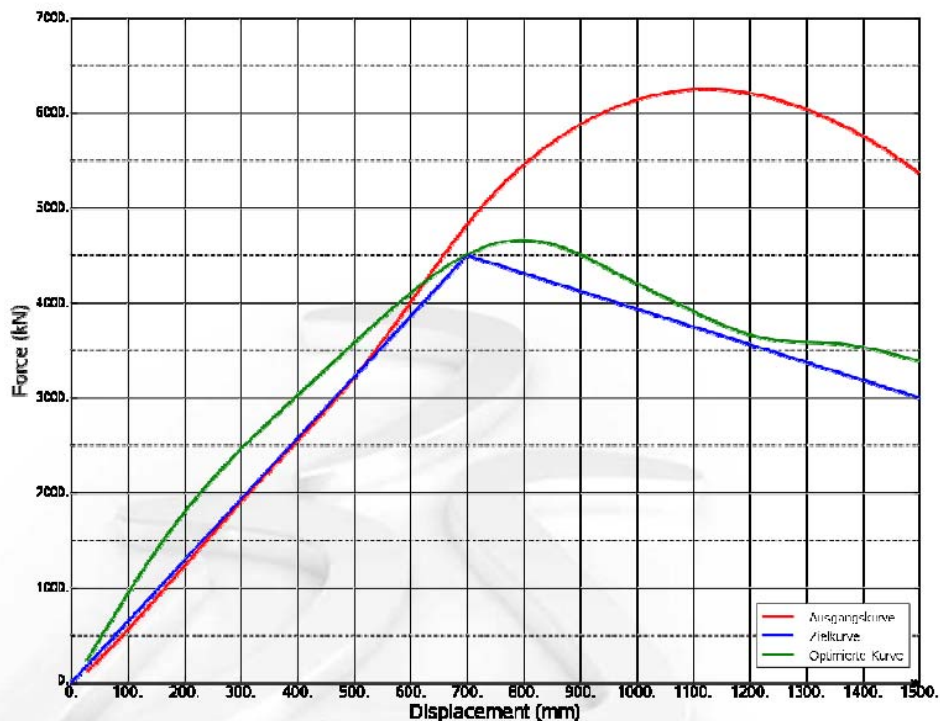

Figure 2. Stiffness characteristics of large deformable obstacle.

In the first phase of the crash process the crash modules and the coupler come in contact with the lower part of the heavy large obstacle. The forces induce the coupler to deform and to release. The crash modules partially deform. Successively, the obstacle contacts the crash wall and the A-pillars, which distribute the load to the crash boxes and to the long beams of the upper frame (see figure 3).

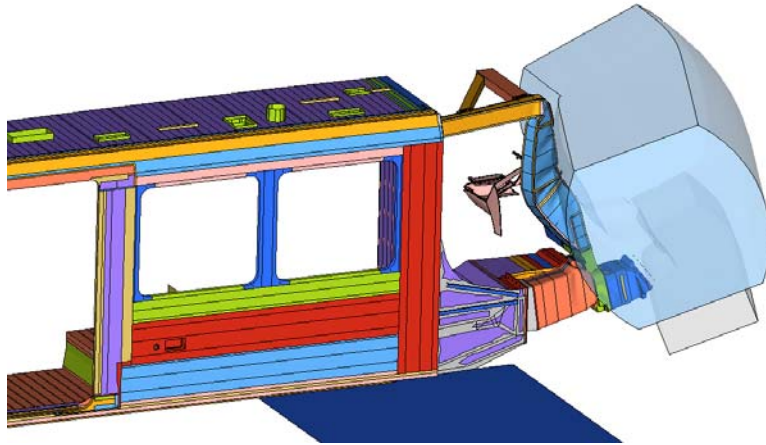

Figure 3. Collision Scenario 3 – Deformed Plot

A maximum force peak of 2'991 kN is obtained after 56 ms, when the obstacle contacts the crash wall and the A-pillar (see figure 4). The average force level during the whole crash process corresponds to 1'503 kN. The maximum deformation, measured between the anti-climber front side and the crash box back side, corresponds to 510 mm. The minimum distance between the heavy obstacle and the driver desk corresponds to 5 mm. Thus, the survival space of the driver (defined in EN15227) is not intruded. The average deceleration value corresponds to 2.00 g.

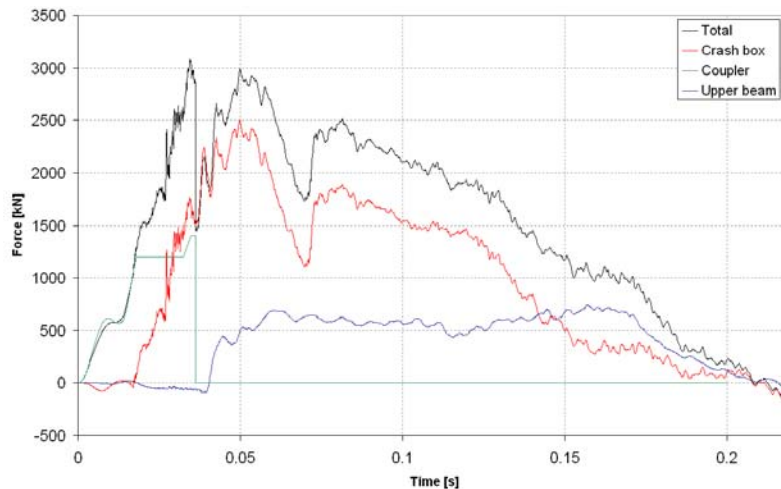

Figure 4. Collision scenario 3 – force (kN)-time (s) behavior.

3. Requirements of FRA Waiver Regulation Defined by RSAC ETF I

In the document waiver regulation ‘Technical Criteria and Procedures for Evaluating the Crashworthiness and Occupant Protection Performance of Alternately-Designed Passenger Rail Equipment for Use in Tier I Service’, DRAFT RSAC REPORT - 6-11-10, issued by the FRA, additional structural requirements and passive safety requirements are defined.

3.1 FRA collision scenario:

The collision scenario defines the collision of a train with a conventional locomotive-led passenger train at a closing speed of 32.2 kph (20 mph). The locomotive-led train consists of one leading, conventional locomotive weighing 117 tons (260,000 lbs) and five conventional passenger cars each weighing 43,1 tons (95,000 lbs).

The following criteria have to be matched:

- Preserve interior spaces occupied by passengers.
 - The occupied volume for the passengers shall have no more than 254 mm (10 inches) of longitudinal, permanent deformation; or
 - Global vehicle shortening shall be no more than 1% over any 4,5 meters (15 ft) of the occupied volume.
- Maintain safe secondary impact environment.
 - Compare the secondary impact velocity (SIV) curve, calculated at the center of gravity (CG) of each car/locomotive, to the SIV curve associated with the 8g, 250-millisecond triangular crash pulse.
- Preserve interior space for engineer.

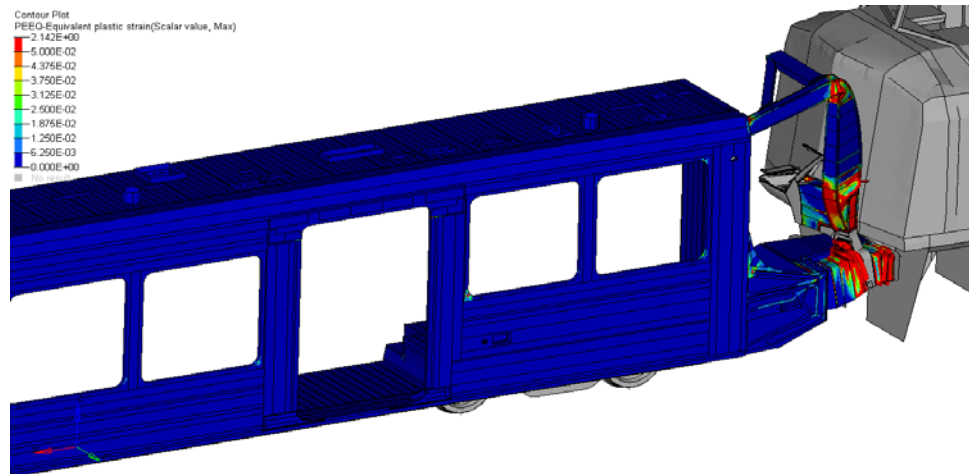

Figure 5. Collision scenario – deformed shape after collision.

The permanent deformation of the structure is concentrated at the front end. The aluminum profiles fold plastically and absorb the energy required. The energy absorption capacity of the

structure is not exhausted at the end of the collision. The level of longitudinal forces introduced in the collision reaches 2800 kN (see figure 6). Since the crippling load of the structure is considerably higher (6200 kN), the structural integrity of the survival zone of the passengers and of the engineer is guaranteed.

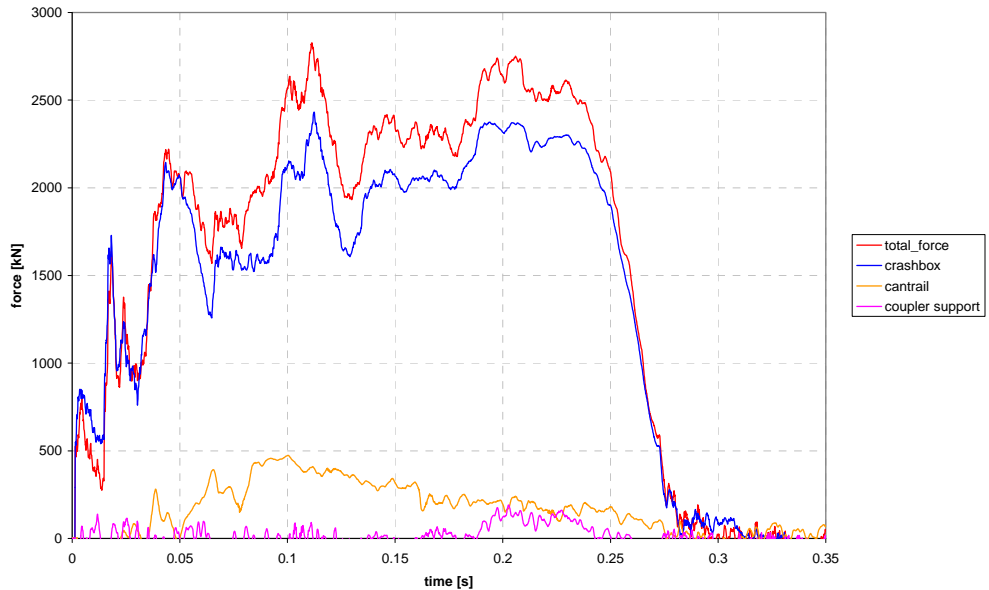

Figure 6. Collision scenario – force-deflection-curve

3.2 Occupied Volume Integrity

Since railway car body structures have been designed to withstand the loads (like a compressive force of 1500 kN) defined in EN 12663, the FRA requirement of 3560 kN (800,000 pounds) cannot be fulfilled without permanent deformation of the car body. For that reason, alternative requirements have been defined to achieve an equivalent proof to guarantee the integrity of the occupied volume (passenger and engineer survival zone):

Option A: Passenger equipment shall resist a minimum quasi-static end load of 3560 kN (800,000 pounds) applied on the collision load path without permanent deformation of the occupied volume.

Option B: Passenger equipment shall resist a minimum quasi-static end load of 4450 kN (1,000,000 pounds) applied on the collision load path with limited permanent deformation of the occupied volume. This load shall be supported without exceeding either of the following two conditions:

- Local plastic strains of 5%; or

- Vehicle shortening of 1% over any 15 ft of the occupied volume.

Option C: Passenger equipment shall resist a minimum quasi-static end load of 5340 kN (1,200,000 pounds) applied on the collision load path without crippling the body structure. Crippling of the body structure is defined as the maximum point on the load-displacement characteristic.

The car body is loaded by compressive forces applied in the attachment points of the crash energy management structure at the front end while the rear end is held by a rigid wall. The CEM structure as well as couplers and articulations are removed from the analysis model.

In figure 7 the force – displacement characteristics is shown for the GTW end car. The criteria for all three options are met: 1% local plastic strain is induced at a compressive force of 4450 kN (1000 pounds). 5% local plastic strain is reached at a compressive force of 6620 kN (1,400,000 pounds). The crippling force is determined at a force level of 6450 kN (1450000 pounds).

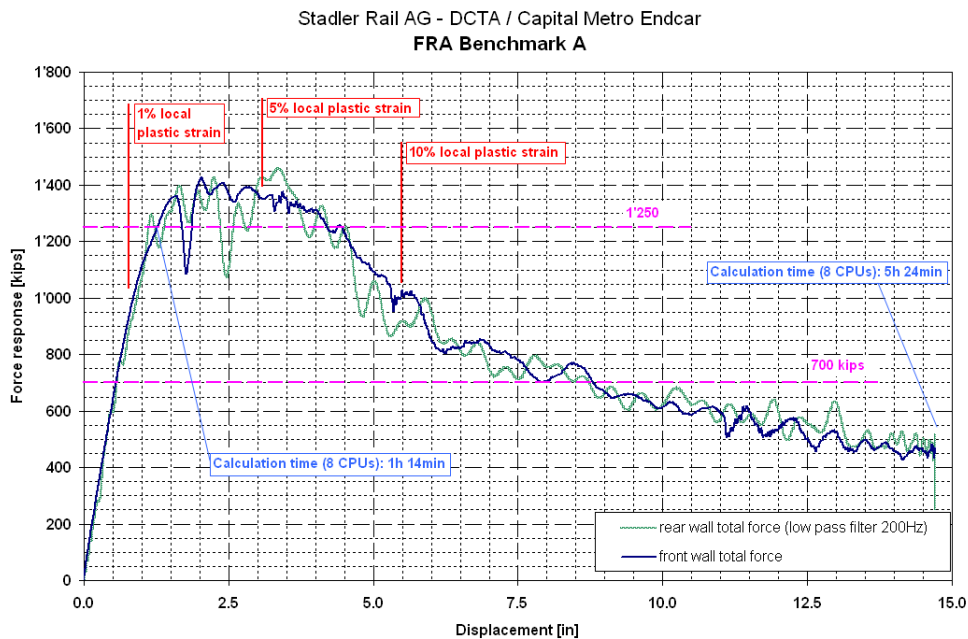

Figure 7. Occupied volume integrity: force-deflection-curve.

3.3 End Structure Integrity of Cab End

Additionally, a further requirement is posted to demonstrate the crashworthiness of the cab end structure. A rigid cylinder of a mass of 10 tons is fired against the front end structure of the train

(see figure 8, as specified in Title 49 CFR § 238.209. Forward end structure of locomotives, including cab cars and MU locomotives, Appendix F to Part 238—Alternative Dynamic Performance Requirements for Front End Structures of Cab Cars and MU Locomotives). This collision scenario requires a maximum crash energy absorption of 360 kJ by the car structure. The deformation of the car end structure resulting from the impact is smaller than the allowed limit of 254 mm (10 inches). In figure 9 the deformation is shown for this scenario. The maximum deformation reaches 250 mm in the impact zone.

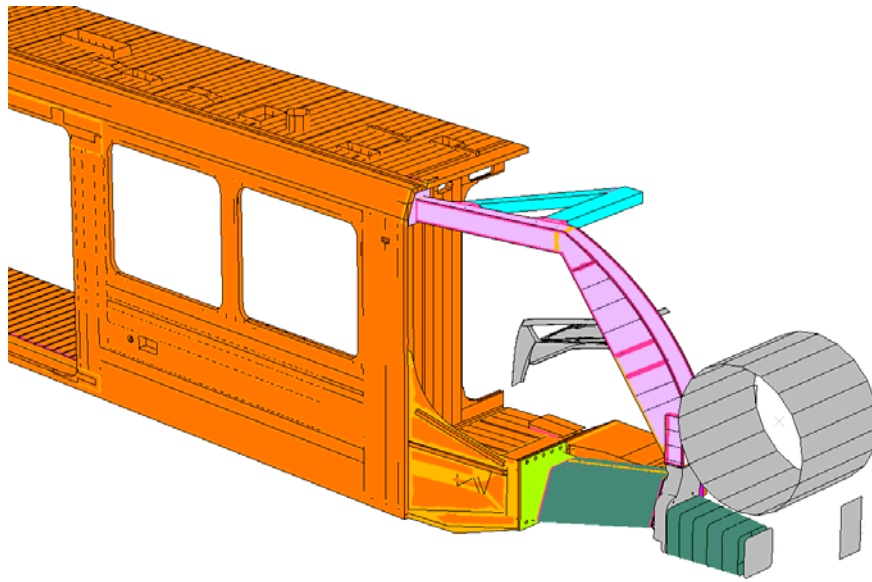

Figure 8. Corner post scenario

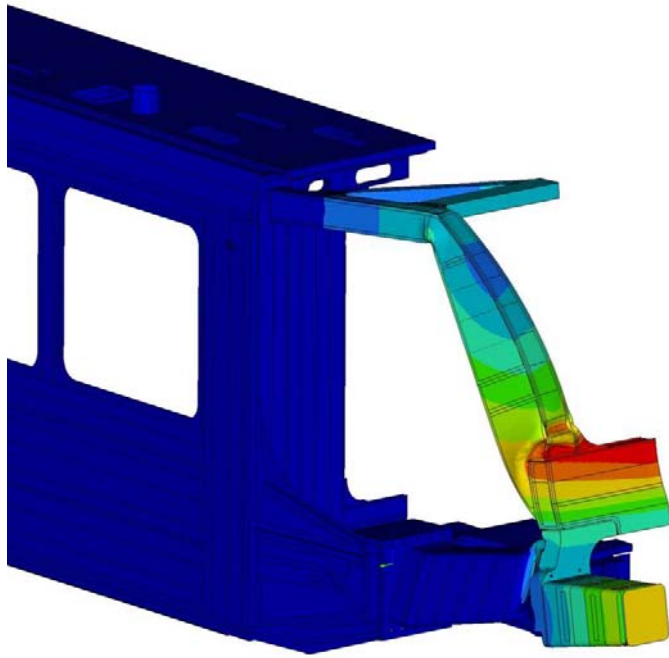

Figure 9. Corner post scenario – deformed plot

4. Conclusions

The Stadler railway vehicles GTW DMUs for Capital Metro, Austin, and DCTA, Dallas, Texas, are compliant with the requests of the new European crashworthiness standard EN15227.

Numerical analyses have shown that the new crashworthy train design guarantees sufficient and controlled energy absorption and maintains the survival space required. Dynamic testing of the crash absorber modules has validated the results of the nonlinear analyses.

In the course of the certification process in the United States an engineering task force established by the RSAC of Federal Railroad Administration (FRA) has defined additional requirements.

Based on the numerical analyses performed with ABAQUS Explicit and Standard all criteria have been met. The numerical results have been validated by static and dynamic testing.

5. REFERENCES

1. EN15227, “Crashworthiness Requirements for Railway Vehicle Bodies”, 2008.
2. EN12663-1, “Railway applications - Structural requirements of railway vehicle bodies”, 2010.
3. FRA waiver regulation ‘Technical Criteria and Procedures for Evaluating the Crashworthiness and Occupant Protection Performance of Alternatively-Designed Passenger Rail Equipment for Use in Tier I Service’, DRAFT RSAC REPORT - 6-11-10, issued by Engineering Task Force I, November 2010.
4. Title 49 CFR § 238.209. Forward end structure of locomotives, including cab cars and MU locomotives, Appendix F to Part 238—Alternative Dynamic Performance Requirements for Front End Structures of Cab Cars and MU Locomotives.
5. Alois Starlinger, Andreas Gmür, Benedetto Castelli and Oliver Liebhard; “On the 40mm Vertical Offset Criterion to Prevent Overriding in the prEN15227: Numerical Analyses and Dynamic Testing of Different Anti-Climb Unit Designs“; 6th International Symposium on Passive Safety of Rail Vehicles, 2006, Berlin.