

Skid against Curb simulation using Abaqus/Explicit

Dipl.-Ing. A. Lepold (FORD), Dipl.-Ing. T. Kroschwald (TECOSIM)

Abstract: *Skid a full vehicle against a curb in lateral and longitudinal direction are two out of several tests to proof the strength of a suspension. Knowing the internal forces acting on suspension components during such an event is extremely important for being able to dimension safety critical parts correctly. Measuring these loads is an elaborate task, because the use of wheel force transducers is not possible due the risk of damaging them. It is necessary to apply strain gauges and force cells instead.*

Therefore the possibility of a fully virtual approach using Abaqus/Explicit would be of great value. A Mc Pherson front suspension has been used as an example to demonstrate :

- *Retrieving internal suspension forces*
- *Verifying the "Chain of Failure"*

for a STUDY to virtually "Skid a Vehicle against a Curb" in longitudinal direction. Correlation with actual force measurements will reveal the potential as well as the restrictions of using such an approach for load prediction and verification.

Furthermore an attempt will be made to transfer the full vehicle impact tests / simulations to suspension level testing. Both a suspension impact rig as well as a simple static suspension strength rig will be set up in the real and the virtual world.

Keywords: *Collapse, Impact, Multi-Body Dynamics, Suspension, Tires, Strength Event, Load Prediction*

1. Introduction

Different car manufacturers conduct strength tests for their vehicles traditionally with different setups. Qualitatively these strength events look quite similar :

- Longitudinal and vertical overload : "Drive over Curb"
- Longitudinal and lateral overload : "Skid against Curb"

The differences lie within the chosen parameters for curb height, vehicle loading, speed, etc. Also the suspension settings, e.g. sportive versus comfortable have a quite significant influence on the level of forces generated internally in the suspension.

These force levels are used to distinguish between different classes of strength events. Mainly three classes of events have been defined as shown in Figure 1.

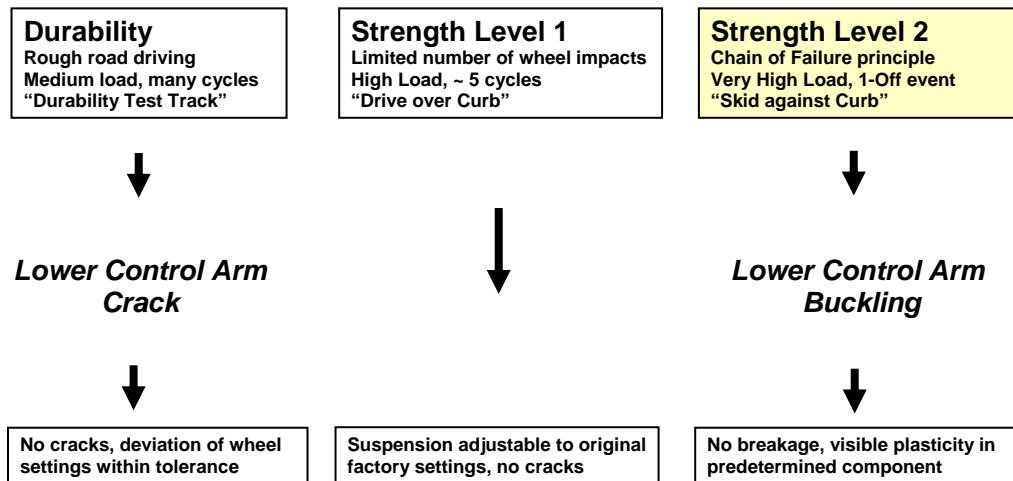

Figure 1. Classification of Customer Usage for Strength & Durability.

The left boxes represent driving on the proving ground durability test track. Several thousands of medium high load repetitions occur on these kind of rough road surfaces. The requirement is that the test is passed without cracks and the suspension alignment, e.g. toe and camber settings remain within the specified tolerances.

Strength events Level 1 are shown in the middle column (Lepold, 2006). Here the load level is high, typically 1.5 times higher than the peak load found on the durability track. However the number of repetitions is much lower, usually the event is not driven more than 5 times. Also here no cracks are allowed and it should be possible to align the suspension back to its original factory settings after the test.

This paper deals with a STUDY on strength tests Level 2, especially the "Skid against Curb" event in longitudinal direction as indicated in the right column. These are so called 1-Off events, i.e. driven once only. After the test a predetermined component has been deformed plastically, e.g. the front Lower Control Arm has buckled. This design feature of using a component to act as a "fuse-element" in order to protect its surrounding is called "Chain of Failure" principle. No separation is allowed. The load level is significantly higher than Level 1.

The tire model used to carry out the Strength Level 2 simulations was detailed enough in order to guarantee a representative stiffness in all directions.

Different material properties have been used for the different rubber mixtures for tread, sidewall, inner liner and apex (see Figure 2). Carcass and belt were modeled with REBAR layers embedded to shell elements representing cord and steel plies oriented in various directions.

While the behavior of the tire model is very important for generating realistic force levels on "Drive over Curb" events, e.g. allow for enveloping of the curb and strike through to the curb it is of less importance for "Skid against Curb" events, as here the impact occurs directly to the rim.

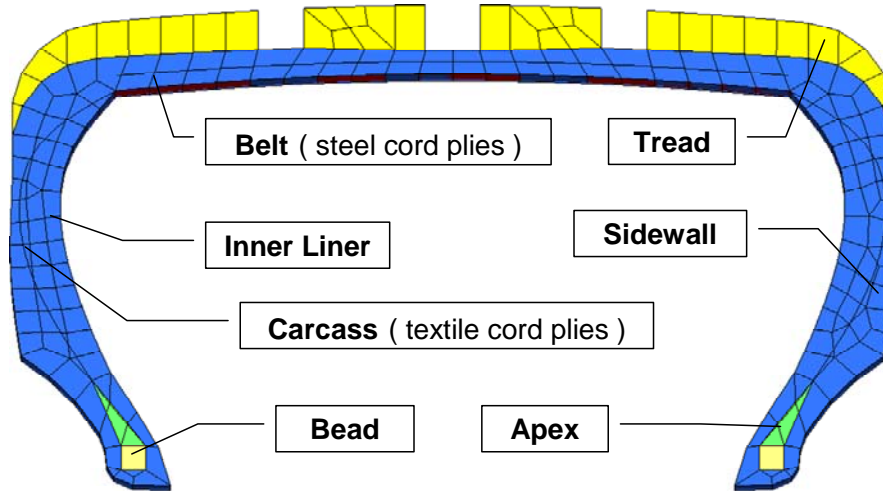

Figure 2. Cross Section of Tire model.

2. Suspension under Investigation

The front suspension used on the test vehicle is of the type "Mc Pherson" as shown in Figure 4. Lateral and longitudinal loads are mainly transferred via the Lower Control Arm and the Subframe to the Body Structure. Therefore the interface between Lower Control Arm and Knuckle, the Lower Balljoint was instrumented with strain gauges as shown in Figure 3 to measure lateral and longitudinal forces.

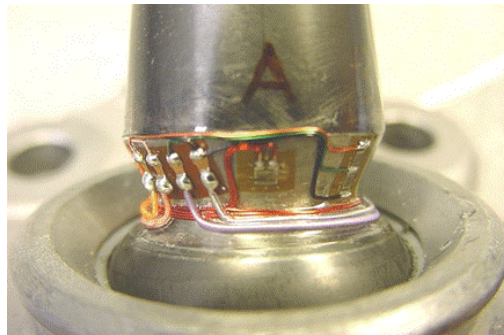

Figure 3. Instrumented Balljoint Pin.

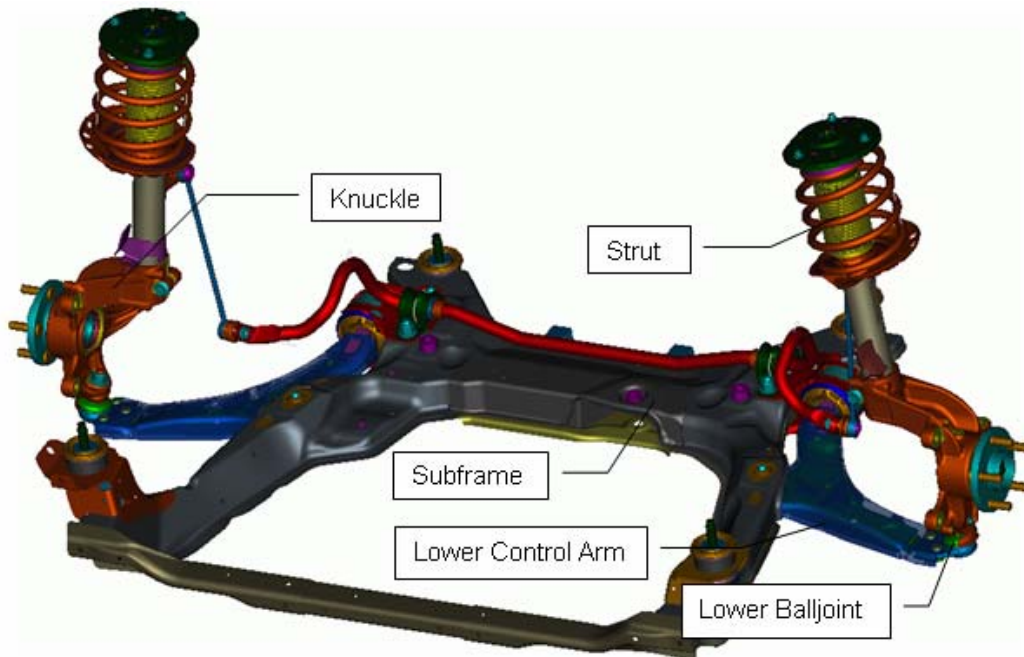

Figure 4. Mc Pherson Front Suspension.

3. Full Vehicle Simulation

A Full Vehicle was Skid against a Curb in longitudinal direction both in the real and virtual world (Figure 5a / b). The test was driven as a Level 2 event, i.e. the speed was high enough to buckle the Lower Control Arm. The vehicle was put on trolleys in the lab in order to allow a controlled and repeatable movement with fully blocked and steered wheels. The height of the curb was chosen in a way to guarantee impact to the lower edge of the rim.

The simulation model in Abaqus/Explicit contains both front and rear suspensions as detailed FE structures. Suspension components that allow for kinematic movements, like bushes, bumpers, dampers & springs were modeled with CONNECTOR type elements. The body was represented by a concentrated mass in the center of gravity of the vehicle with correct moments of inertia. Substituting it with a flexible structure reduced the internal force levels by approximately 5 %.

The barrier itself was modeled as a rigid surface, with a friction coefficient simulating concrete as it was used in the real test. Contact conditions were defined in the model in regions where it was

appropriate. Friction coefficient between tire and road was assumed to be $\mu = 0$. The analysis was done in 3 steps :

STEP 1 : Apply pre-tension on coil springs with fixed wheel centers

STEP 2 : Release wheel center fixation and get equilibrium with gravity load

STEP 3 : Skid vehicle against Curb

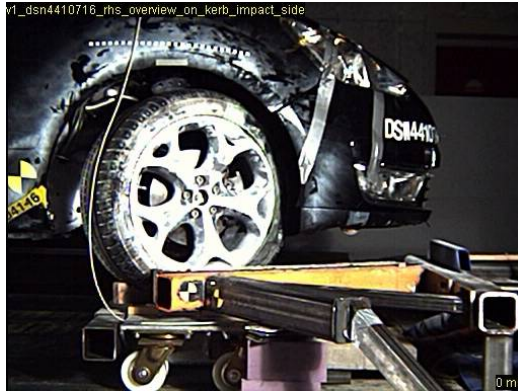

Figure 5a. Full Vehicle - TEST.

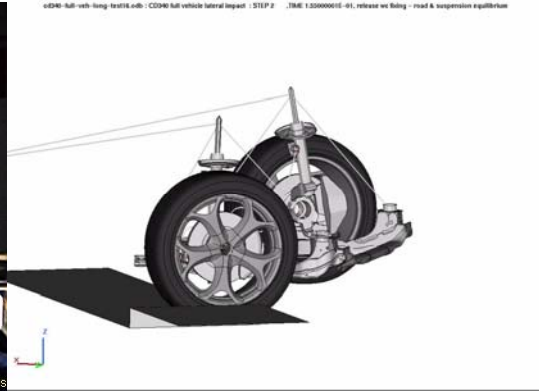

Figure 5b. Full Vehicle - CAE.

Correlation between test and simulation was established both qualitatively by comparing the buckling shapes as well as quantitatively by comparing the force levels.

The Lower Control Arm buckled between its attachments to the Subframe as expected from CAE prediction, see left hand side buckling area on Figures 6a / b.



Figure 6a. Longitudinal Buckling - TEST.

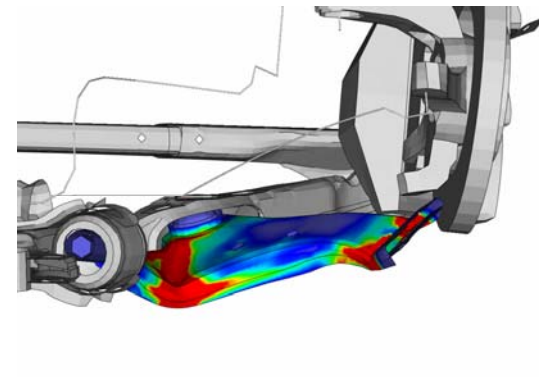

Figure 6b. Longitudinal Buckling - CAE.

However a second buckling mode was initiated in CAE as shown on the right hand side in Figure 6b at a trigger that had been deliberately designed into the Lower Control Arm to provoke lateral

buckling. This indicates, that the simulation model is reflecting reality not yet properly in the lateral direction. This was also confirmed when looking at the lateral forces measured at the Lower Balljoint as shown in Figure 7. The impact duration was shorter and the force level 27% above test. A reason could be that so far static characteristics have been used for rubber bushes. Changing to dynamically measured force displacement curves is expected to slow down the force build up in lateral direction as there will be more load capacity in longitudinal direction in the first place due to reduced rotation of the arm.

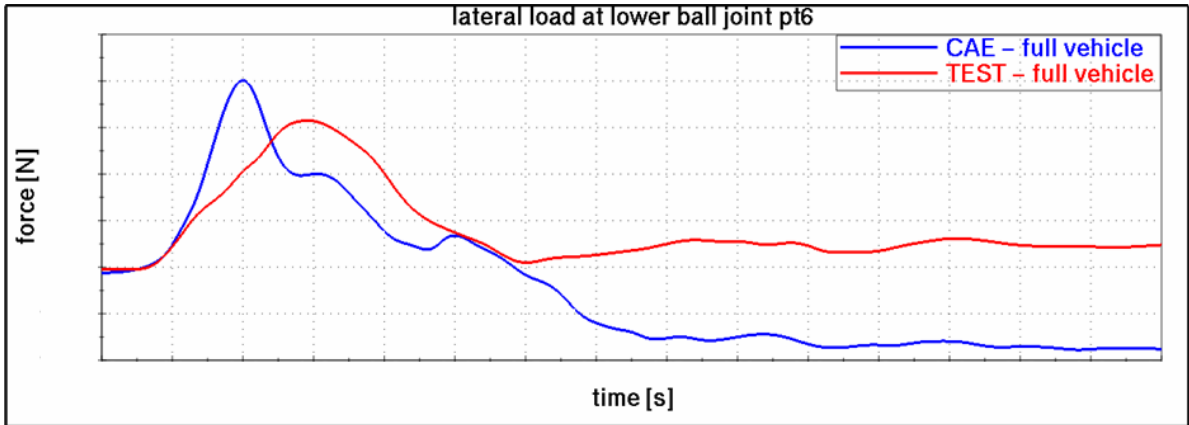

Figure 7. Lateral Force Full Vehicle Test versus CAE.

The longitudinal forces matched quite well between Test and CAE as can be seen in Figure 8.

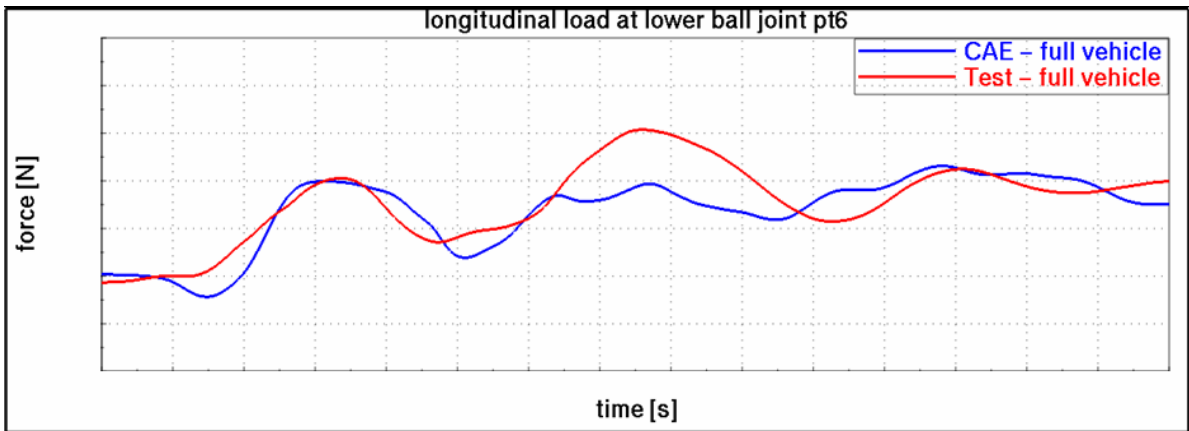

Figure 8. Longitudinal Force Full Vehicle Test versus CAE.

There was a difference though with regard to the post buckling behavior. At about 0.27 sec there was a second force peak that occurred on test only. Possible root cause could be that the Lower Control Arm got stuck in the wheel after buckling. Here the simulation model needs improvement.

The Chain of Failure principle worked out fine. Firstly the damage was clearly visible to the customer due to misalignment of the wheel after test (Figures 9a / b).



Figure 9a. Before Test.



Figure 9b. After Test.

Secondly the force level was limited via the Lower Control Arm taking enough energy out of the system to protect its surrounding components. The magnitude of the resultant x-/ y-force for the second force peak at about 0.27 sec was lower than the peak buckling force at 0.22 sec. Except for the Lower Control arm no other parts were damaged and had to be replaced after the test.

4. Suspension Impact Rig

Due to the fact that full vehicle prototypes are available very late in the program it was necessary to set up a representative rig test on suspension level in order to support platform development.



Figure 10a. Susp Impact - TEST.

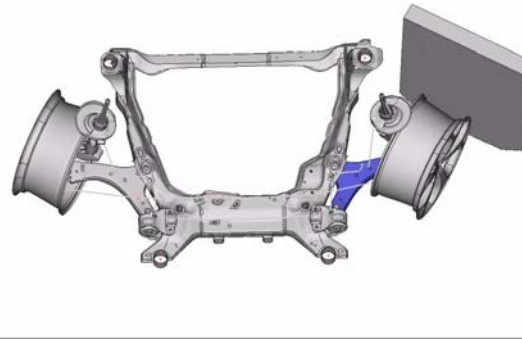

Figure 10b. Susp Impact - CAE.

Rather than driving the vehicle against a curb, now a sledge was driven against the wheel rim of a suspension mounted to a dummy front end body structure (see Figure 10a / b).

The wheel was fully steered outboard in order to generate the same rearward inboard loading condition like in the full vehicle test. Mass and speed of the sledge were related to the maximum front axle mass of the vehicle.

Qualitatively a good correlation was achieved for the buckling mode, see Figures 11a / b.



Figure 11a. Impact Rig Buckling - TEST. Figure 11b. Impact Rig Buckling - CAE.

The impact duration of approximately 40 milliseconds matched reasonably well between CAE and test on suspension level as shown in Figure 12 as well as with the full vehicle test Figures 7 / 8.

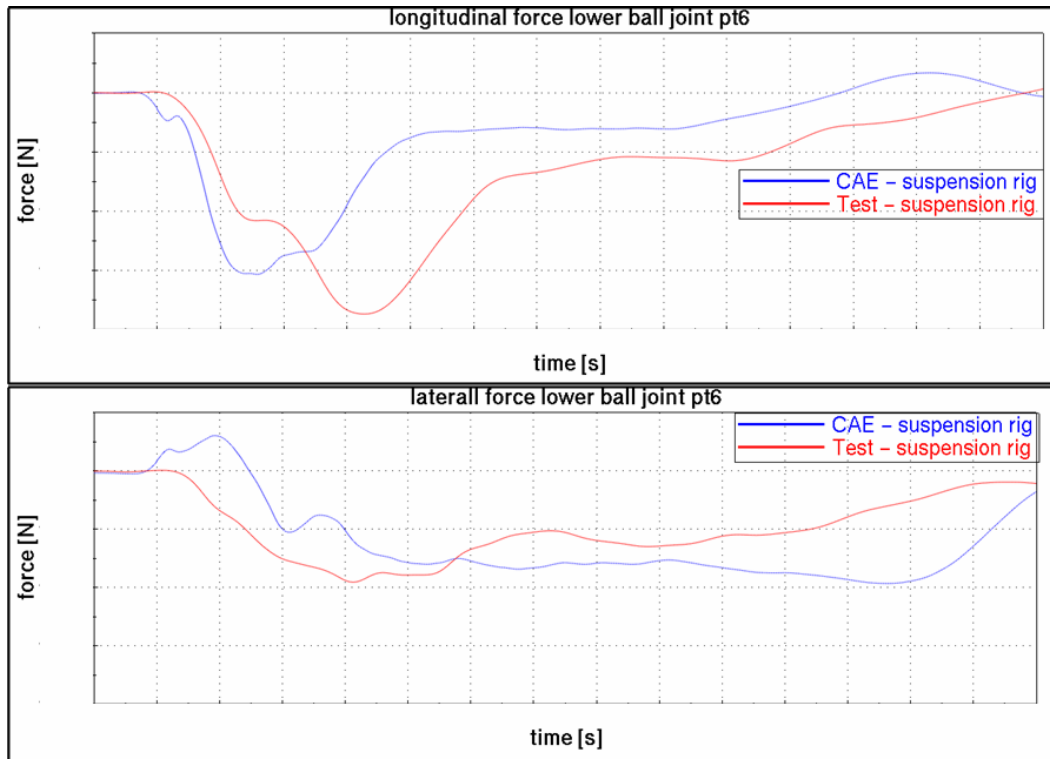

Figure 12. Longitudinal and Lateral Force Suspension Impact Rig Test versus CAE.

Force levels do not correlate between full vehicle and suspension impact yet. Optimizing speed and mass of sledge on the suspension rig is considered as next step for improvement. Comparing

force levels between CAE and test on the suspension rig, CAE is under-predicting by 20% in the longitudinal direction. The test result showed a significant lateral force contribution at the buckling point in time. This is not the case in the simulation and an indication, that in reality the rearward movement is larger than in the simulation, causing rotation of the wheel about the vertical axis and thereby generating higher lateral load input. In order to better align test and CAE for the suspension impact it will be necessary to include the flexibility of the body structure and possibly also dynamic bush characteristics.

5. Static Suspension Strength Test

A further simplification would be to substitute the dynamic impact test on suspension level with a static strength test, where a high force is applied to the tire patch in rearward inboard direction as shown in Figure 13.

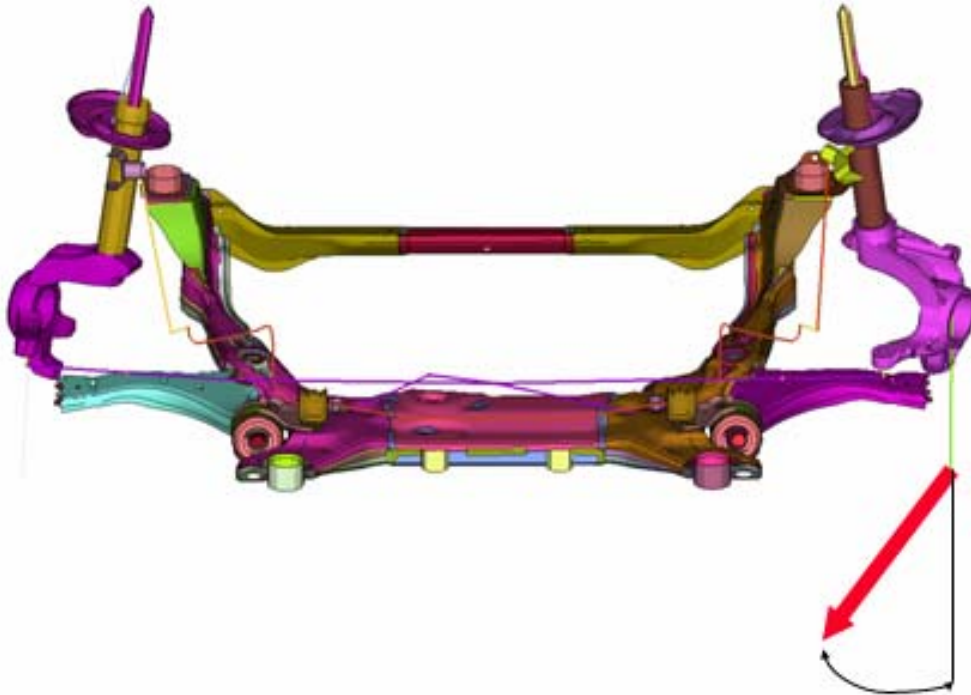

Figure 13. Static Strength Test with angled load input at Tire Patch.

This test has not yet been set up, however CAE indicates that correlation with the full vehicle test can be achieved as long as it is assured that the rotation about the lateral vehicle axis is kept free in the wheel centre. Then the Lower Control Arm buckles as expected and shown in Figure 14.

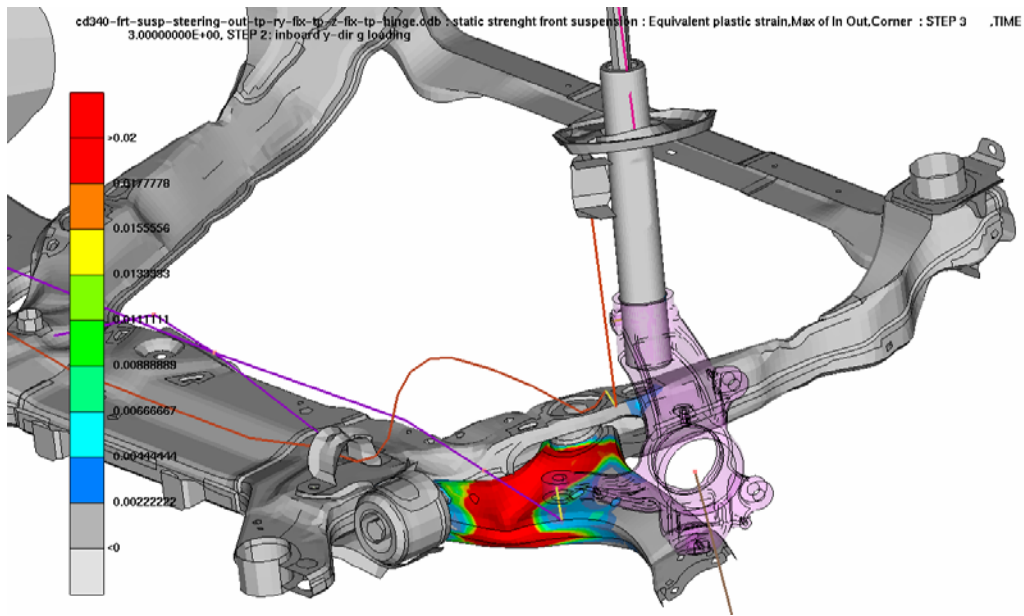

Figure 14. Buckled Arm and Bent Strut on Static Strength Test.

The static analysis was done using Abaqus/Standard. The model of the strut was refined and bolt pre-tension was added for the interface strut to knuckle.

6. Summary

A good correlation between Test and CAE was found for the full vehicle impact simulation with regard to the buckling mode of the Lower Control Arm as well as quantitatively when comparing force levels. There is room for improvement for the lateral direction where CAE is over-predicting the loads measured in test. Enhancing the simulation model in the area where the arm hits the wheel as well as introducing dynamic bush characteristics with end stop is planned as next steps.

On the suspension impact rig the buckling behavior is reflected correctly, however impact mass and speed need to be optimized in order to match load magnitudes with full vehicle impact testing.

Using simple static testing on suspension level would be the preferred way forward with regard to speeding up the development process however the predicted failure mode needs to be confirmed with physical test.

7. References

1. Lepold, A. "DOE for classification of Strength Events", VDI-Berichte Nr. 1967, 2006, pg 725