

Transmission Efficiency Prediction of a Metal Pushing V-belt CVT with Implementation of Control Logic

Toshihiro Saito

Honda R&D Co., Ltd. Automobile R&D Center

Koji Miyamoto

ITO CORP.

Victor Oancea, and Kunming Mao

Dassault Systemes Simulia Corp.

Abstract: A simulation technology has been developed to predict the transmission efficiency of a metal pushing V-belt and pulleys that make up the drive system of a continuously variable transmission (CVT). When a CVT operates in an actual vehicle, pulley thrust pressure is adjusted by feedback control to maintain a speed ratio. This feedback control has been implemented, for the first time, in an existing simulation that predicts the dynamic behavior of a metal pushing V-belt using Abaqus/Explicit version 6.8-1 analysis. The new simulation enables stable control of a target speed ratio when appropriate gains are set for each analysis condition. Using this simulation, the following values can be obtained: 1) pulley thrust pressure that is necessary for maintaining a specified speed ratio but could previously be derived only from physical testing, 2) transmission efficiency of a CVT drive system, consisting of a metal pushing V-belt and pulleys under each operating condition, and 3) feasibility study is now available for the actual CVT configuration.

Keywords: Controller, Dynamics, Interface Friction, and Powertrain.

1. Introduction

Nowadays automobiles are required to meet environmental requirements, such as lower exhaust emissions and higher fuel economy. One of the key factors for improving the overall efficiency of a vehicle is the efficiency of its transmission.

A CVT has a greater potential for improving fuel economy than a step-type automatic transmission (AT), because of its integrated control with the engine⁽¹⁾. That is, CVTs are capable of continuously tracing engine operating ranges with high fuel efficiency. Another advantage is that CVTs allow vehicles to drive without lowering the driving torque or the engine rpm while shifting the gear ratio.

However, when the transmission efficiency of a CVT by itself is compared with a step-type AT, CVT is known to have lower efficiency because its driving torque is transferred by means of

contact and friction⁽²⁾. The transmission efficiency of a CVT is determined by friction loss at its oil pump and metal pushing V-belt. The oil pump must produce enough pulley pressure so that the metal V-belt mounted between two pulleys does not slip. A higher pulley pressure, however, means a greater friction loss at the oil pump⁽³⁾.

As for the metal V-belt, gradually lowering pulley pressure while maintaining a constant transmission torque increases the transmission efficiency of the belt by itself, as long as it does not slip on the pulleys. However, the transmission efficiency begins to drop under a certain operating condition. This implies the existence of an optimum operating condition that maximizes the transmission efficiency of the belt⁽⁴⁾. To find this condition, it is important to predict friction loss at each portion of the metal V-belt during CVT operation.

A considerable amount of research has so far been made on methods for calculating friction loss that occurs at each part of the V-belt, but many of them use simple equations that are based on assumptions and not linked with dynamic belt behavior⁽⁵⁾. Accordingly, although these methods simulate the tendency of friction loss on each belt part, they are not sufficient for examining the influence on friction loss of metal belt shape and pulley rigidity.

The following describes how CVT-ratio control logic was included in the previously reported technology for simulating the dynamic behavior of a metal pushing V-belt, and presents how the new simulation can closely reproduce actual operation. Thus, this paper reports a technology developed to predict the transmission efficiency of a CVT drive system comprising a metal pushing V-belt and pulleys.

2. Development Aims

2.1 Maintaining Speed Ratio with Feedback Control

Fig. 1 shows the main section of the CVT used in this development. A metal V-belt is mounted in the V groove on two pulley shafts, and a pair of movable pulleys are mounted on the shafts to face each other. The movable pulleys are shifted in the axial direction by line oil pressure supplied from the inside of the shaft. When the CVT is in operation, feedback control is exercised to maintain an arbitrary speed ratio between the two pulleys, varying the oil pressure applied to the large-diameter (in terms of belt mounting position) pulley while maintaining a constant pressure for the small-diameter pulley. When taking an example of the top ratio, the drive pulley speed, driven pulley torque, driven pulley oil pressure, and target ratio are input to the feedback control system. The system then outputs the driven pulley speed, drive pulley torque, and drive pulley oil pressure. The input-output relation differs from the metal V-belt behavior simulation technology developed previously, so it was necessary to incorporate a new feedback control into the simulation in this project.

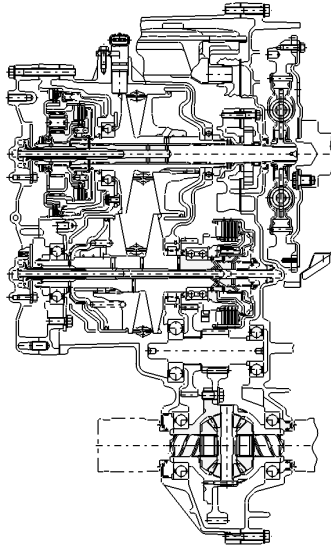

Figure. 1 Main section

2.2 Pulley Shaft Thrust Load Ratio

Pulley shaft thrust load is obtained as the sum of two values: the product of oil pump line pressure and its acting area, as well as the product of centrifugal oil pressure and its acting area. The ratio between drive pulley thrust load and driven pulley thrust load, referred to as the pulley shaft thrust load ratio, has a positive correlation with the speed ratio; therefore, this ratio is uniquely determined once the speed ratio is set. Because the developed simulation outputs pulley shaft thrust loads, its prediction accuracy can be verified by comparing simulated and measured values.

2.3 Transmission Efficiency

Transmission efficiency can be obtained by multiplying the ratio between drive shaft torque and driven shaft torque by the speed ratio, as expressed in Equation (1). Here, each torque value can be obtained as the product of a tangential friction force, generated between the V-face of each pulley and metal V-belt elements, and the effective element V-surface radius. As such, it is necessary to accurately predict the direction of a friction force acting on each element V-surface and its effective radius under that condition. The effective radius of the element V-surface is influenced by its contact pressure distribution. This means that it is also necessary to consider the elastic deformation of the element V-surface.

For this reason, to simulate the transmission efficiency of the metal pushing V-belt, the following were set as development objectives:

- 1.** Implement feedback control equivalent to speed ratio control performed in an actual vehicle
- 2.** Quantify sliding velocities and friction forced at various element contact areas
- 3.** Feasibility study for actual CVT configuration

3. Technology to Predict Transmission Efficiency of Metal Pushing V-belt

3.1 V-belt Model in Consideration of Element Deformation

The transmission efficiency of a metal pushing V-belt is mainly determined by friction losses that occur between its elements and pulleys and between the elements and rings. Friction loss has a correlation with the product of the friction force and sliding velocity of a friction surface. Accordingly, a key to predicting the transmission efficiency is to simulate the friction forces and sliding velocities of the element V surfaces in contact with the pulley. These friction forces and sliding velocities have distributions on the pulley, and these distributions cannot be simulated accurately unless element deformation is taken into account (Fig. 2). Because the effective radius of elements would be influenced by the contact pressure distribution. For this reason, an element stress prediction model⁽⁶⁾ previously designed to consider element deformation was modified to make a model of the metal V-belt used in this study.

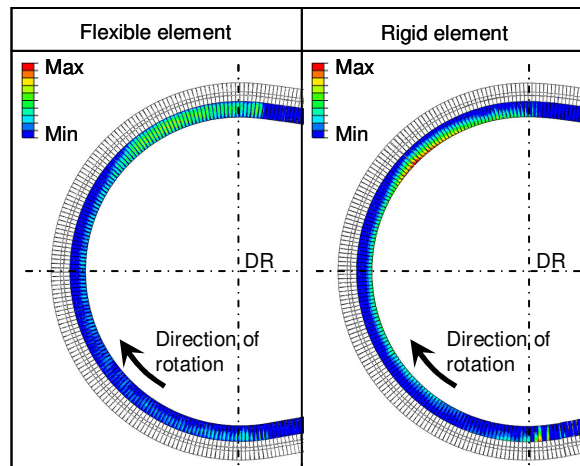

Figure. 2 Comparison of friction force distribution of Element V-surfaces on DR pulley

Fig. 3 and Fig. 4 show the model. To make the load conditions around the belt pulleys closely resemble the layout in an actual CVT, beam elements were used to express the shafts. In this model, the shafts are supported at the bearing positions. Also, a gear is provided to mesh with the driven (DN) shaft to reflect reaction forces applied by the gear. Because the belt mounting diameter varies depending on speed ratios, deflection rigidity calculated for the mounting positions of each ratio was applied to the pulley V-face. Regarding the relation between each shaft and the movable pulley, the model defines a fitting clearance at their engagement position, as well as a backlash in the rotational direction at the roller position.

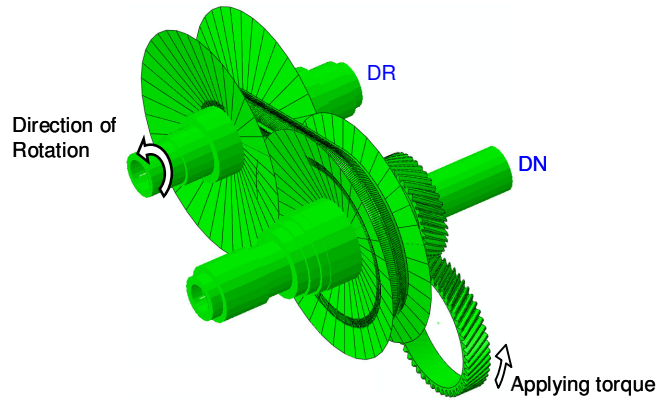

Figure. 3 Metal V-belt model for predicting transmission efficiency considering shaft deformation

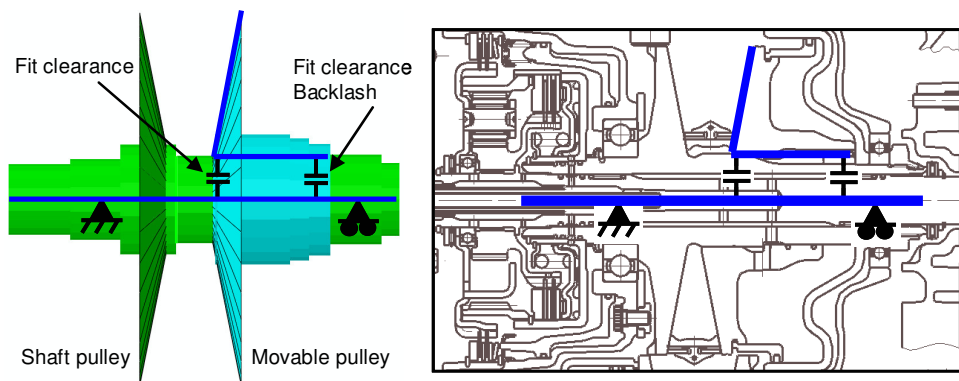

Figure. 4 Boundary condition around pulley shaft

Fig. 5 shows the flow of analyzing the metal V-belt. In this flow, the belt is initially placed at the perfect-circle position under no stress, and then both pulleys are moved to a specified shaft distance. Next, misalignment is applied to one of the pulleys. Then, the drive pulley is gradually accelerated to reach a target speed, while pulley thrust pressure is being applied. In the meantime, reverse torque is gradually applied to the driven pulley.

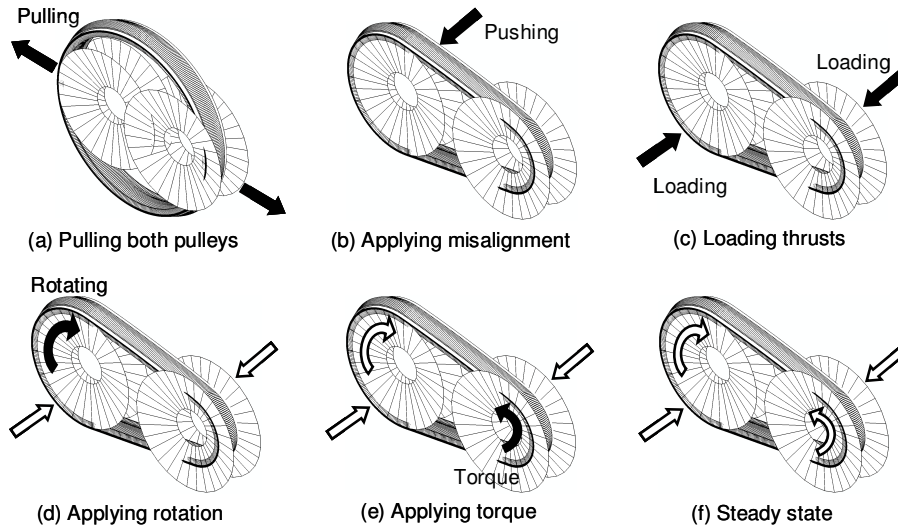

Figure. 5 Analytic procedure

4. Belt Transmission Efficiency Prediction using Pulley Thrust Pressure Control

The transmission efficiency η of the V-belt can be obtained by the following equation:

$$\eta = \frac{\omega_{dn} \times T_{dn}}{\omega_{dr} \times T_{dr}} = i \frac{T_{dn}}{T_{dr}} \quad (1)$$

ω_{dr} : drive (DR) shaft speed ω_{dn} : driven (DN) shaft speed i : ratio
 T_{dr} : DR shaft torque T_{dn} : DN shaft torque

Thus, the DR shaft torque, DN shaft torque, and ratio must be obtained to predict efficiency η . The conventional element stress prediction model required simulations to be made based on pulley thrust pressures measured in an actual CVT. Unlike element stress measurement, the transmission efficiency can be easily measured in an actual vehicle, but it would be impractical for a simulation to require actual measurements to predict the efficiency. Accordingly, a pulley thrust controller used in the previous research⁽⁷⁾ was implemented in the simulation to apply pulley thrust pressure that depended on each operating condition.

Fig. 6 is a block diagram of the thrust controller. Enclosed in the dashed box in this figure is a traditional proportional-integral (PI) controller. This controller calculates the actual ratio from ω_{dr} and ω_{dn} of the belt model, and adjusts pulley thrust pressure by means of a feedback loop until the ratio reaches a target value I_{target} . Controller gains were re-defined because the previous metal V-belt model was replaced with the element stress prediction model.

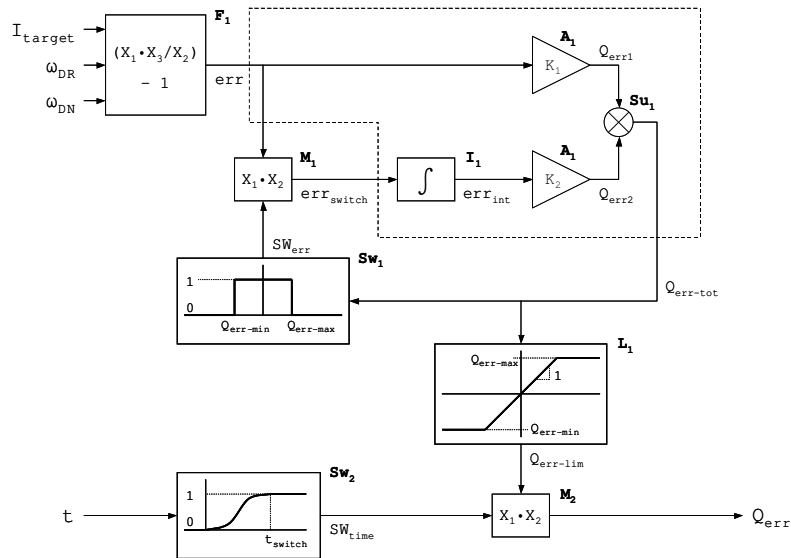
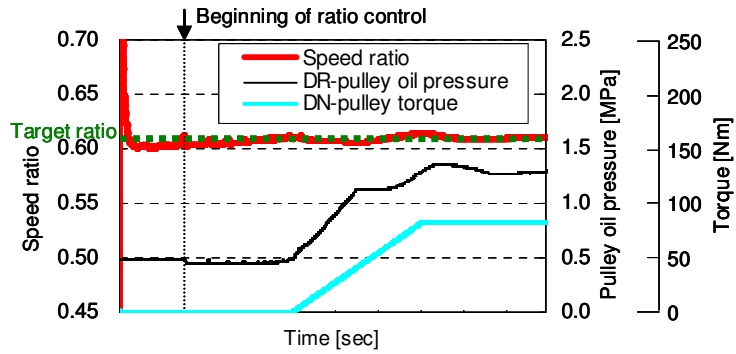

Figure. 6 Thrust controller block diagram

Fig. 7 shows calculations made with the metal V-belt model incorporating the above pulley thrust pressure control. In this simulation, ω_{DR} , T_{DN} , and the driven pulley thrust pressure Q_{DN} were given as input, and the drive pulley thrust pressure Q_{DR} was controlled to make the actual ratio reach the target value. Because speed ratio error must be considered in deciding the Q_{DR} control value, pressure was applied before starting the rotation. Then, ratio control was started after making sure that the actual ratio had been read accurately. As demonstrated in Fig. 7, the speed ratio is maintained at the target value when the pulley thrust pressure is controlled by the ratio controller.

Fig. 8 shows the belt transmission efficiency obtained from the computation result of this model. As shown here, the simulation implementing pulley thrust pressure control enables transmission efficiency prediction at a target speed ratio.



a) With ratio controller

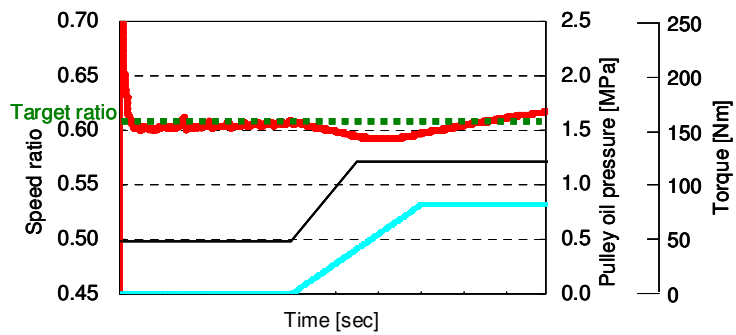

b) Without ratio controller

Figure. 7 Effect of ratio controller

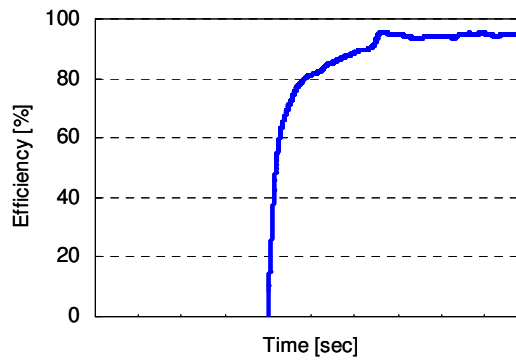

Figure. 8 Calculated transmission efficiency of metal V-belt with ratio controller

5. Belt Transmission Efficiency at Different Ratios

In a CVT equipped with a metal pushing V-belt, the transmission efficiency is known to peak at the speed ratio of 1.0 (MID). The efficiency lowers gradually while a vehicle is decelerating (shifting to LOW) or accelerating (shifting to OD). The developed simulation was used to calculate friction loss at each portion of the metal V-belt at different speed ratios.

5.1 Accuracy of Belt Efficiency Prediction

Fig. 9 shows belt transmission efficiency calculated for and measured at the MID, LOW, and OD ratios under a certain operating condition. Fig. 10 shows the calculated and measured pulley shaft thrust load ratios. Both graphs indicate the same tendency, which verifies the validity of simulations at all ratios.

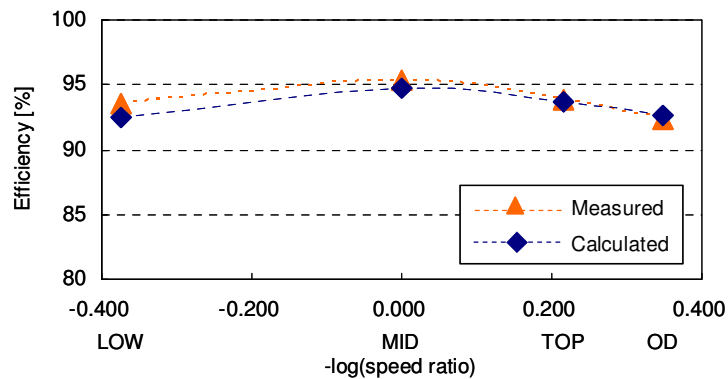

Figure. 9 Belt transmission efficiency

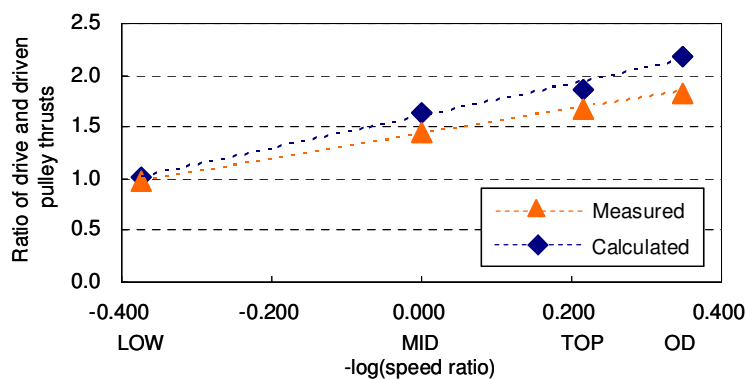

Figure. 10 Ratio of drive and driven pulley thrusts

6. Application for actual CVT configuration

Figure 11 shows an actual CVT configuration to be calculated the transmission efficiency. Replacement of the former single-piston configuration with double pistons aligned in the axial direction has resulted in approximately 1.8 times more thrust at identical oil pressures. This has reduced line pressure when the CVT is in its frequently used overdrive ratio, thus reducing the pump workload. Figure 12 shows Von Mises stress distribution except the gears. Most of the parts are now modeled as flexible bodies.

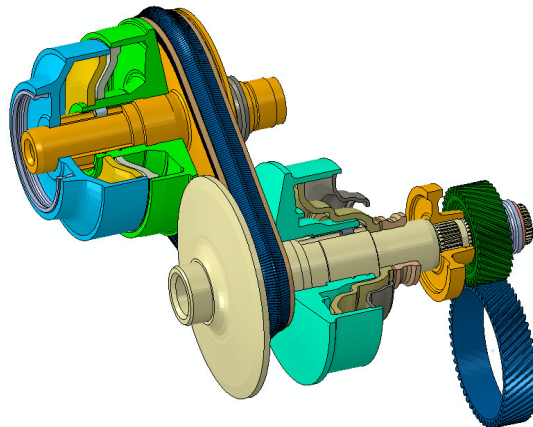

Figure. 11 Metal V-belt model considering pulley V-surface deformation

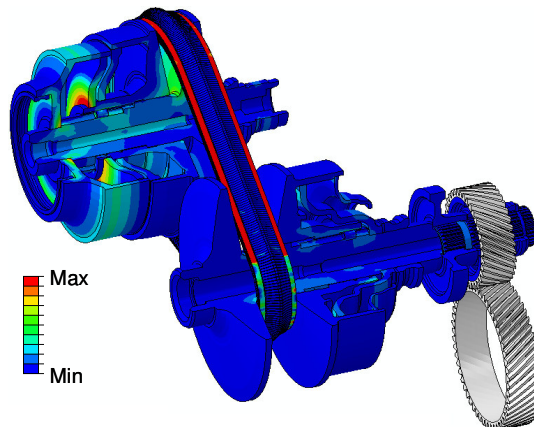

Figure. 12 Stress distribution of Metal V-belt and pulleys

The transmission efficiency is now predicted using pulley thrust pressure control with appropriate control gains. (Figure 13) The speed ratio is kept at a target speed ratio during this simulation.

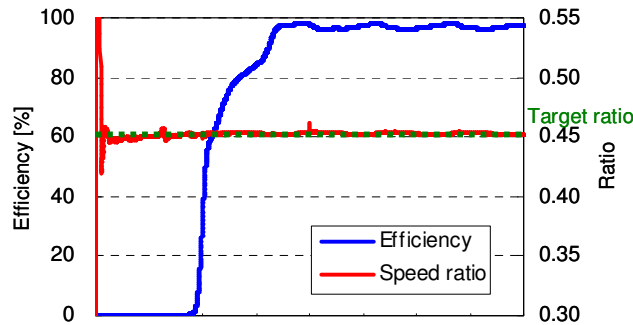

Figure. 13 Calculated transmission efficiency of metal V-belt with FEM pulleys

7. SUMMARY

1. Feedback control to maintain speed ratios in an actual CVT has been implemented in a metal V-belt behavior simulation, making it possible to predict the CVT transmission efficiency under an arbitrary operating condition.
2. This simulation has successfully quantified sliding velocities and friction forces of element contact areas along the entire length of the V-belt.
3. The simulation technique was also available for actual CVT configuration to predict the transmission efficiency using flexible pulley components.

8. References

1. Yamamoto, K., Sakaguchi, S., Kishida, M., Kimura, E. and Abe, H., "Development of Integrated Engine-CVT Control System," Honda R&D Technical review, Vol. 11, No. 1
2. Akehurst, S., Vaughan, N. D., Parker, D. A. and Simner, D., "Modelling of loss mechanisms in a pushing metal V-belt continuously variable transmission. Part 1: torque losses due to band friction," Proc. Instn Mech. Engrs vol. 218 Part D: J. Automobile Engineering
3. Veenhuizen, P. A., Bonsen, B., Klaassen, T.W.G.L., Albers, P.H.W.M., Changenet, C. and Poncy, S. "Pushbelt CVT efficiency improvement potential of servo-electromechanical actuation slip control," 2004 CVT Congress
4. Van der Noll, E., Van der Sluis, F., Van Dongen, T. and Van der Velde. A. "Innovative Self-optimising Clamping Force Strategy for the Pushbelt CVT," SAE Paper, 2009-01-1537
5. Narita, K. and Priest, M. "Metal-metal friction characteristics and the transmission efficiency of a metal V-belt-type continuously variable transmission," Proc. IMechE vol.221 Part J: J. Engineering Tribology

- 6.** Saito, T. "Application of Stress Simulation Under Transient Condition for Metal Pushing V-belt of CVT," SAE Paper, 2008-01-0415
- 7.** Saito, T. and Lewis, D. A. "Development of a Simulation Technique for CVT Metal Pushing V-belt with Feedback Control," SAE Paper, 2004-01-1326