

Operating Instructions



ServiceJunior



SensoControl®

Contents

| | | |
|----------|--------------------------------------------|-----------|
| 1 | Introduction | 2 |
| | 1.1 Notes on safety / production selection | 2 |
| | 1.2 Device versions and range of delivery | 3 |
| 2 | Commissioning | 4 |
| | 2.1 Replacing the batteries | 4 |
| 3 | Functions and keys | 6 |
| | 3.1 Display mode | 8 |
| | 3.2 Menu functions | 9 |
| 4 | Connection to the hydraulics | 11 |
| 5 | Operating the ServiceJunior | 13 |
| | 5.1 Turning on (ON) | 13 |
| | 5.2 Turn off (OFF) | 14 |
| | 5.3 Turn on backlight | 14 |
| | 5.4 MIN/MAX indication | 14 |
| | 5.5 FS Full Scale display | 15 |
| | 5.6 Erasing the MIN/MAX values | 15 |
| | 5.7 OFL Display | 15 |
| | 5.8 Zero point correction (ZERO) | 15 |
| | 5.9 Resetting the zero point correction | 17 |
| | 5.10 Automatic power off | 17 |
| | 5.11 Changing the unit | 18 |
| | 5.12 Filter settings | 19 |
| | 5.13 Display serial number | 20 |
| 6 | Technical data | 21 |

1 Introduction

The ServiceJunior is a digital manometer featuring a Min/Max display function. Full scale (FS) accuracy is $\pm 0.5\%$ based on the upper limit of the measurement range.

Dynamic pressure peaks are measured at a scanning rate of 10 ms (100 measurement values/second). The MIN/Max memory is continuously updated and rewritten.

1.1 Notes on safety / production selection

The correct functioning of the ServiceJunior can only be guaranteed when the specifications detailed in these operation instructions are adhered to. In particular, specifications relating to the permitted upper limit of the measurement range as well as the permissible temperature range must be observed.



Serious malfunctions leading to personal injury or damage to property can result from using the chosen product in applications that do not comply with the specifications or from disregarding the operating instructions. In particular, incorrect mounting of the manometer and the corresponding adapter can cause the manometer to be torn out of the assembly.

For repairs or calibration of the measurement instruments, please contact a Parker sales branch.

1.2 Device versions and range of delivery

| Device versions / range of delivery | | | |
|--------------------------------------------------------------------------------------------------------|--------------|-------------------------------------------------------------------------------------------------------------------|--------------|
| Basic setting to unit 'bar' Pressure connection, male thread G1/4 Delivery with adapter M16x2 | | Basic setting to unit 'PSI' Pressure connection, male thread UNF 7/16-20 Delivery without adapter | |
| Measurement range | Order No. | Measurement range | Order No. |
| -1...16.00 bar | SCJN-016-01 | -1...230.0 | SCJR-230-02 |
| 0...100.0 | SCJN-100-01 | 0...1500 | SCJR-1500-02 |
| 0...400.0 | SCJN-400-01 | 0...5800 | SCJR-5800-02 |
| 0...600.0 | SCJN-600-01 | 0...8700 | SCJR-8700-02 |
| 0...1000 | SCJN-1000-01 | | |



2 Commissioning

The ServiceJunior is supplied with batteries fitted. The device is operational as soon as it is turned on.

2.1 Replacing the batteries



Caution!

Turn off the device before replacing the batteries. Open the battery compartment. Insert the new batteries as depicted. Ensure correct polarity of the batteries.

Batteries: 2 x 1.5 V (LR6 - AA)



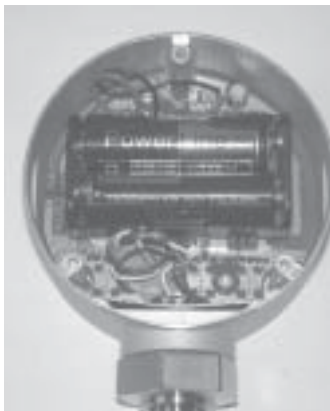

When in continuous operation (without light), the service life of the batteries is 1,500 hours.



A battery symbol permanently displays the actual battery status.

3 Functions and keys

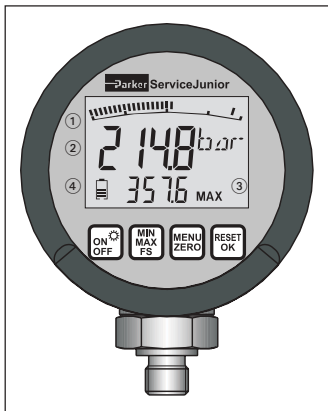





Display

- 4 $\frac{1}{2}$ digit LCD with backlight
 - Displays measurement values and menu functions
- ① Bar graph with Peak & Hold function
 - ② Actual value display (15 mm)
 - ③ MIN/MAX or Full Scale (8 mm)
 - ④ Battery status

Keys



| Key | Function | |
|----------------------------------------------------------------------------------|----------------------------------------------------------------------------------------------------|--------------------------------------------------------------------------------------------------------------------------------|
|  | ON/OFF  | Turns the device on / off. Press for 2 seconds. Turns on the back-light (stays on for 20 seconds). |
|  | MIN MAX FS | Selects display unit: MIN, MAX or FS Minimum value Pressure peak Displays the upper limit of the scale (e.g. 400 bar) |
|  | MENU ZERO | Press for 2 seconds. Changes the unit. Auto Power Off – on/off. Zero point calibration. |
|  | RESET OK | Erases MIN and MAX values from the memory. Confirms the MENU functions. |

3.1 Display mode

The actual pressure (ACT) is indicated in the display mode. The ACT measured value is displayed in the corresponding unit. The MIN, MAX or FS values is indicated in the lower part of the display.

| Display | Description |
|------------------|--------------------------------------------------------------------------------------------------------------------------------------------------------------------------------------------------|
| Bar graph | Graphic indication of the actual pressure. A pressure peak is indicated by means of a pixel (graduation mark). The indicated value is refreshed at intervals of 50 ms (20 measurements/s). |
| ACT | Indicates the actual pressure. The indicated value is refreshed at intervals of 300 ms (3 times/s). |
| MIN/MAX | Indicates the MIN, MAX or FS value according to setting. The indicated value is refreshed at intervals of 300 ms (3 times/s). |
| FS | Upper limit of the scale (e.g. 400 bar). |
| Units | Indicates the chosen unit. |

| | |
|--------------------------------------------------------------------------------|---------------------------------------------------------------------------------|
|  | Indicates the battery status (5 segments). |
| REC | REC flashes when recording measurement values (optional data logging function). |
| x10 | Indicated value (actual indication and MIN/MAX indication) x10. |

3.2 Menu functions

The following settings can be made in the MENU function:

- Auto Power Off – **on** or **off**
- Unit selection (bar, mbar, PSI, kPa, Mpa)

Press the MENU key for 2 seconds to activate the functions menu.

Press the MENU key again to select the next function.

Press the OK key to save the function setting.

The device then switches to the display mode.

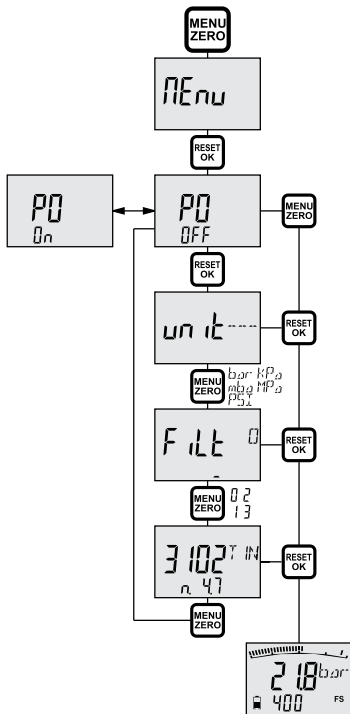

4 Connection to the hydraulics

The ServiceJunior is available with male thread G1/4 (BSPP) or 7/16-20 UNF for the corresponding versions (bar/PSI).

| Device version | SCJN-xxx-01 | SCJR-xxx-02 |
|-----------------------------|---------------|----------------|
| Pressure connection | 1/4 BSPP | 7/16-20 UNF |
| Adapter (M16x2) | SCA-1/4-EMA-3 | SCA-7/16-EMA-3 |
| Test hose (M16x2) | SCA-EMA-3/3 | SCA-EMA-3/3 |
| Gauge connection M16x1.5 | SCA-EMA-3/4 | SCA-EMA-3/4 |
| Gauge connection M12,65x1.5 | SCA-EMA-3/2 | SCA-EMA-3/2 |
| Gauge connection | SCA-EMA-3/1 | SCA-EMA-3/1 |



Observe specified torques when fitting the Service-Junior.

| The spanner size of the pressure connection is 27 mm | |
|------------------------------------------------------|--------|
| Pressure connection | Torque |
| 7/16-20 UNF | 35 Nm |
| 1/4 BSPP | 25 Nm |

When fitting directly, please ensure the ServiceJunior can be rotated freely.

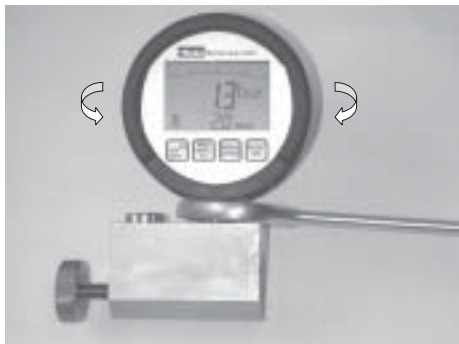

Safety Instructions for using 1.000 bar operating range:

The delivered adapter SCA-1/4-EMA-3 (hex size 27) is approved up to nominal pressure of 1,000 bar. Please pay attention to built in test points acc. to rated nominal pressure and specified safety factor.

5 Operating the ServiceJunior

5.1 Turning on (ON)



A self-test procedure is carried out



The measuring range is indicated (FS)

Unit (**bar**) SCJN-xxx-01

Unit (**PSI**) SCJR-xxx-02



Auto Power Off function is active. Power off activates automatically after 5 minutes. This function can be altered in MENU.



Display mode:
ACT value displayed

5.2 Turn off (OFF)

Press once (briefly)



5.3 Turn on backlight

Press  for 2 seconds.



The backlight goes out automatically after 20 seconds.

5.4 MIN/MAX indication

Use this key to toggle the required value.

The key function is sequential; the values are indicated in the display in sequence.

The MIN/MAX function is used to measure pressure peaks. The respective lowest (MIN) and highest (MAX) measured values are stored in the MIN/MAX memory. Values in the MIN/MAX memory are erased when the device is turned off. If different pressure tests are to be carried out in succession, the MIN/MAX memory must be erased after each measurement.



MIN/MAX/FS value is indicated in the display.

5.5 FS Full Scale display

Displaying the upper limit of the scale (FS) is designed to increase readability of the bar graph function.

The upper limit of the measurement range is indicated numerically. FS is indicated in sequence after MIN and MAX.



FS is displayed.

5.6 Erasing the MIN/MAX values



Erases MIN/MAX values.

5.7 OFL Display



This indicates that the applied pressure is outside given full scale range.

If the message will remain displayed, while the ServiceJunior is pressure less, please consult a Parker Hannifin Sales Office.

5.8 Zero point correction (ZERO)

The zero point can be corrected manually should undesired deviations occur when no system pressure is being applied (atmospheric pressure).



Caution!

The zero point correction sets the current ACT value to zero. In order to exclude erroneous measurements, ensure **no system pressure** is being applied when carrying out this function.



This initiates the zero point correction. The **ACT** (actual) value is indicated in the display as 0.0 bar. The correction remains active until the device is turned off.



OFL/ZERO is displayed for 3 seconds if the measured pressure (0 bar) is greater than 5% of the measurement range.

Zero point correction cannot be carried out. Please ensure that **no system pressure** is being applied.

5.9 Resetting the zero point correction



Turn off the device. Zero point correction is **no** longer active when the device is turned off and on again.

5.10 Automatic power off

Press  for 2 seconds.

Depending on the device configuration, two different displays are possible:

Auto Power Off



PO On

Press . Auto Power Off is activated after 5 minutes.

Continuous operations



PO OFF

Press . The device must be turned off manually.

i The settings Auto Power Off or Continuous operations remain stored and are active when the device is turned off and on again.

5.11 Changing the unit

Press  for 2 seconds.



Press .



Press once (briefly) .

The next unit is indicated.

 Confirm unit selection.

(Measurement range
16 bar/230 PSI)



5.12 Filter settings

Press  for 2 seconds.



Press .



Press .

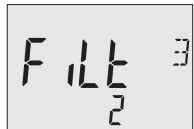

Press once (briefly) .

Filter selection is indicated.



Confirm filter configuration.

5.13 Display serial number

Press .



Display of serial number (1. line).
Display of software version (2. line).



6 Technical data

| | |
|----------------|----------------------------------------------------------------------------------------------------------------------------------------------------------------------------------------------------------------------------------------------------------------------------------------------------------------------------------------------------------------------------------------------------------------------------------------------------------------------------------------------------|
| Version | <ul style="list-style-type: none">– Digital pressure gauge with ACT - MIN and MAX Display– bar graph display 33 segments (with peak and hold function)– 4½ digit LC display (15 mm) with back light illumination– Battery powered with low power electronic system– Life time cycle 1,500 h (No back light function)– Pressure port stainless steel 1.4404– ¼ " BSPP (ISO 1179-2) or 7/16-20 UNF (ISO 11926-2/3) |
| Input | <ul style="list-style-type: none">– Ceramic Sensor cell -1...16 bar– Strain Gauge Cell 0...100/400/600/1,000 bar– Scan rate 10 ms– Resolution 12 bit = 4,096 steps– Accuracy ± 0.25 % FS typ. ± 0.5 % FS max. |
| Housing | Ø = 79 mm; T = 33 mm Zinc Die Cast with Rubber Protection TPE |
| Sealing | Standard NBR sealed Viton® (FKM); EPDM on request |

| | |
|------------------------------------|--------------------------------------------------------------------------------------------------------------------------------------------------------------------------------------------------------------------------------------------------------------------------------|
| Parts in contact with media | Stainless Steel 1.4404, NBR, ceramics |
| Power supply | Battery 2 x1,5 VDC (LR6 –AA) Alkaline (Mignon) |
| Ambient conditions | Operating temperature: -10...50 °C Fluid temperature : -20...80 °C Storage temperature: -20...60 °C Rel. humidity: < 85 % Protection: EN 60529 (IP 67) Vibration: IEC 60068-2-6 5 g Shock: IEC 60068-2-27 25 g Reliability Cycles (10 ⁶): 100 |

Digital Manometer ServiceJunior

| Range bar | Display bar | Display PSI | Display mbar |
|-----------|---------------|---------------|--------------|
| -1...16 | -1.00...16.00 | -14.5...230.0 | -999...16000 |
| 0...100 | 0...100.0 | 0...1500 | - |
| 0...400 | 0...400.0 | 0...5800 | - |
| 0...600 | 0...600.0 | 0...8700 | - |
| 0...1000 | 0...1000 | 0...15000 | - |

| Range bar | Display kPa | Display MPa |
|-----------|----------------|-------------|
| -1...16 | -100...1600 | - |
| 0...100 | 0...10000 | 0...10.00 |
| 0...400 | 0...4000 (x10) | 0...40.00 |
| 0...600 | 0...6000 (x10) | 0...60.00 |
| 0...1000 | - | 0...100.0 |

| | | | | | |
|--------------------------|---------|---------|---------|---------|----------|
| Meas. range (bar) | -1...16 | 0...100 | 0...400 | 0...600 | 0...1000 |
| Overload P_{max} (bar) | 40 | 200 | 800 | 1200 | 1500 |
| Burst pressure (bar) | 50 | 800 | 1700 | 2200 | 2500 |



Exceeding the maximum overload values (P_{max}) can lead to malfunctions and result in the ServiceJunior being destroyed.

Burst pressures are based on data without the M16x2 adapter.

The ServiceJunior meets the guidelines of the European Community (EU). It is confirmed that this product is approved acc. to following standards:



DIN / EN 61000-6-2

DIN / EN 61000-6-3

Technical subject to change.

February 2006

Distributed By:
HOSE & FITTINGS, ETC.
1811 Enterprise Blvd.
West Sacramento, CA 95691
USA
www.hfeweb.com
+ 1.888.297.4673

