



OWNERS - MANUAL

MODEL #909

CHILDREN'S INDOOR OBSTACLE COURSE



MANUFACTURED BY:



"Motivating Kids to Move!"

www.kidsfit.com
2130 Cainhoy Road
Huger, SC 29450

CUSTOMER:



To Our Valued Customer

Thank you for choosing Kidsfit for your fitness equipment needs. In this manual you will find valuable information regarding your new Kidsfit fitness obstacle course. We've included general information on the operation and maintenance of your obstacle course that will help it last longer and remain in top condition. However, it is YOUR RESPONSIBILITY to create a site-specific Operations and Maintenance Manual for your staff that reflects the environment in which you are operating. The operations manual that you create should spell out the following: daily, weekly and monthly cleaning requirements; regular mandatory inspections; rules and regulations for the play area; staff training requirements; and minimum staff expectations. Kidsfit is not responsible for accidents and injuries (including death) resulting from improper use of the equipment and/or improper operation and maintenance of the obstacle course.

This Owner's Manual contains many helpful appendices, including:

- Cleaning Guidelines;
- Inspection & Cleaning Overview Chart;
- Cleaning & Inspection Checklist;

We strongly recommend that, at a minimum, you abide by these helpful appendices, and that you incorporate them into your site-specific Operations & Maintenance Manual and regular operations and maintenance procedures.

Again, thank you for choosing Kidsfit. We appreciate your business and will strive to exceed your expectations relating to our products and services. Please call our Customer Service Department at 843.336.5090 if we may be of assistance.

Sincerely,

Kidsfit
2130 Cainhoy Rd.
Huger, SC 29450
tel: 843.336.5090
fax: 866.730.2419
www.kidsfit.com

Table of Contents

<i>Introduction</i>	Safe Play	5
	Why we provide this important information	5
	Who should read this Manual?	6
	<u>Section 1</u>	
<i>Basics of your Fitness Obstacle Course</i>	List of Tumble Town Fitness Obstacle Course Components	7
	Play Environment	9
	Age Appropriateness and Physical Ability	9
	Kidsfit Warranty Information	10
	Instructional Signage	10
	<u>Section 2</u>	
<i>Operating a Safe Play Environment</i>	Playground Safety Summary	11
	Operation Guidelines	11
	Local Regulations	11
	Fitness Obstacle Course Rules	12
	Staff Training and Responsibilities	12
	Safety Surfacing Types and Warnings	12
	Alteration of the Obstacle Course and/or Equipment	13
	Regular Inspections, Cleaning and Maintenance	13
	Spotting and Preventing Misuse	13
	Corrective Action	14
	Inaccessible Areas of the Obstacle Course	15
	Barriers to Prevent Climbing	15
	Control Access to the Obstacle Course	16
	Summary of Operating a Safe Play Environment	16
	A.S.T.M. Definitions and Information	17
	<u>Section 3</u>	
<i>Inspecting, Cleaning and Maintenance</i>	General Information	19
	General Cleaning Guidelines and Recommendations	20
	Daily Inspections and Daily Cleaning Overview	20
	Daily Cleaning	20
	Daily Inspections and Daily Cleaning Overview	21
	Weekly Cleaning and Inspections	21
	Weekly Cleaning and Inspections Overview	22
	Obstacle Course Maintenance	22
	Periodic “Tune-up”	22
	Monthly, Quarterly and Annual Inspections	22
	Static Electricity	23
	Summary	23

Cleaning Guidelines

Appendix A

Do's and Don'ts	24
To Clean Plastics, Vinyls and Major Components	24
To Clean Domes and Windows	25
To Remove Spray Paint or Markers from Windows	25
To Remove Spray Paint or Markers from Vinyls	25
To Remove Scuff Marks from Plastics	25
To Remove Stains from Ropes and Webbing	25
To Clean Components with Graphics	25
To Clean Indoor Activity Centers	25
Safety Surfacing	25
Safety Surfacing Cleaning and Maintenance	25

***Inspection and Cleaning
Overview Chart***

Appendix B

Handy Reference Chart	27
-----------------------	----

***Daily Cleaning and
Inspection Checklist***

Appendix C

Handy Reference Checklist and Action Report	28
---	----

INTRODUCTION

Safe Play

Kidsfit encourages safe play. In creating this manual, Kidsfit draws on the combined input and expertise of safe-play advocacy organizations, industry experts, governmental organizations, and Kidsfit's own vast experience in active play since 1999.

These guidelines, along with local, regional and national laws and regulations (where applicable), should be followed to ensure a safe play environment and extend the life of your Obstacle Course. Included with this manual is the manufacturer's recommended user capacity limit for structural integrity, as defined by ASTM F1918-04, Section 11.4.1.2. It is the obstacle course operator's responsibility to monitor and determine optimum user capacity limits for safe play.

This manual suggests minimum maintenance guidelines. Because each play system environment is different, you should evaluate your play area needs based on customer usage, location, and other factors specific to your site. **Kidsfit strongly recommends that you create your own Operations and Maintenance Manual based on your site's particular needs.**

Maintenance is YOUR responsibility. Please protect users of the playground equipment with daily inspections as well as regular and thorough maintenance and cleaning. You and your staff should be aware of any unsafe condition(s) and be prepared to take immediate corrective action.

This manual should be kept for reference for as long as you own your Kidsfit Fitness Obstacle Course.

IF YOUR PLAY SYSTEM IS EVER MOVED OR SOLD, THIS MANUAL SHOULD BE INCLUDED WITH THE EQUIPMENT AND PROVIDED TO THE NEW OWNER. To ensure that all current safety and accessibility guidelines are followed, Kidsfit fitness obstacle course should be dismantled, moved and reinstalled **ONLY BY QUALIFIED INSTALLERS**. Kidsfit is not responsible for any equipment that is dismantled, moved, and/or reinstalled by anyone other than a **QUALIFIED Kidsfit installer**.

Why We Provide This Important Information

The purpose of this Owner's Manual is to provide you with general instructions, suggestions and tips as to how to clean and maintain your Kidsfit Fitness Obstacle Course Equipment at a level of performance that will provide a safe and enjoyable play environment for your customers, extend the life of the obstacle course components, and conform to Kidsfit Warranty requirements.

NOTE: This Owner's Manual should be used in conjunction with your company's internal training and operations manuals and your own operating experience to create site-specific manuals, policies and procedures for the operation and maintenance of your Obstacle Course Equipment. This Owner's Manual is not an "Operations Manual", and the owner/ operator should not treat it as such.

The Owner/Operator of an Obstacle Course bears the ultimate responsibility for staff training, Obstacle Course System monitoring, and equipment maintenance. ASTM F1918-04, Section 11.5 through 11.9 explains the responsibilities of the owner/ operator for care and maintenance. Furthermore, the CPSC cannot stress enough the importance of cleaning and maintaining your Obstacle Course.

If you should have questions regarding your Kidsfit Fitness Obstacle Course, contact Kidsfit's Customer Service Department at 843.336.5090.

Who Should Read This Manual

Kidsfit recommends that all staff, including managers and employees who will be involved with Fitness Obstacle Course Equipment operations, read the entire Owner's Manual, in conjunction with your company's internal training and operations manuals, prior to initial operation of your fitness obstacle course. With the aid of such manuals, combined with your own experience specific to your site, the owner/operator and its managers and employees should draft and employ site-specific manuals, policies and procedures for the operation and maintenance of the obstacle course. You should take into account issues such as average and peak usage of the play area, types of users, types of use, staffing requirements, birthday parties, etc. when establishing an operations manual.

BASICS OF YOUR FITNESS OBSTACLE COURSE

Tumble Town Fitness Obstacle Course

The following pages contain a list of your Tumble Town Fitness Obstacle Course Equipment components.

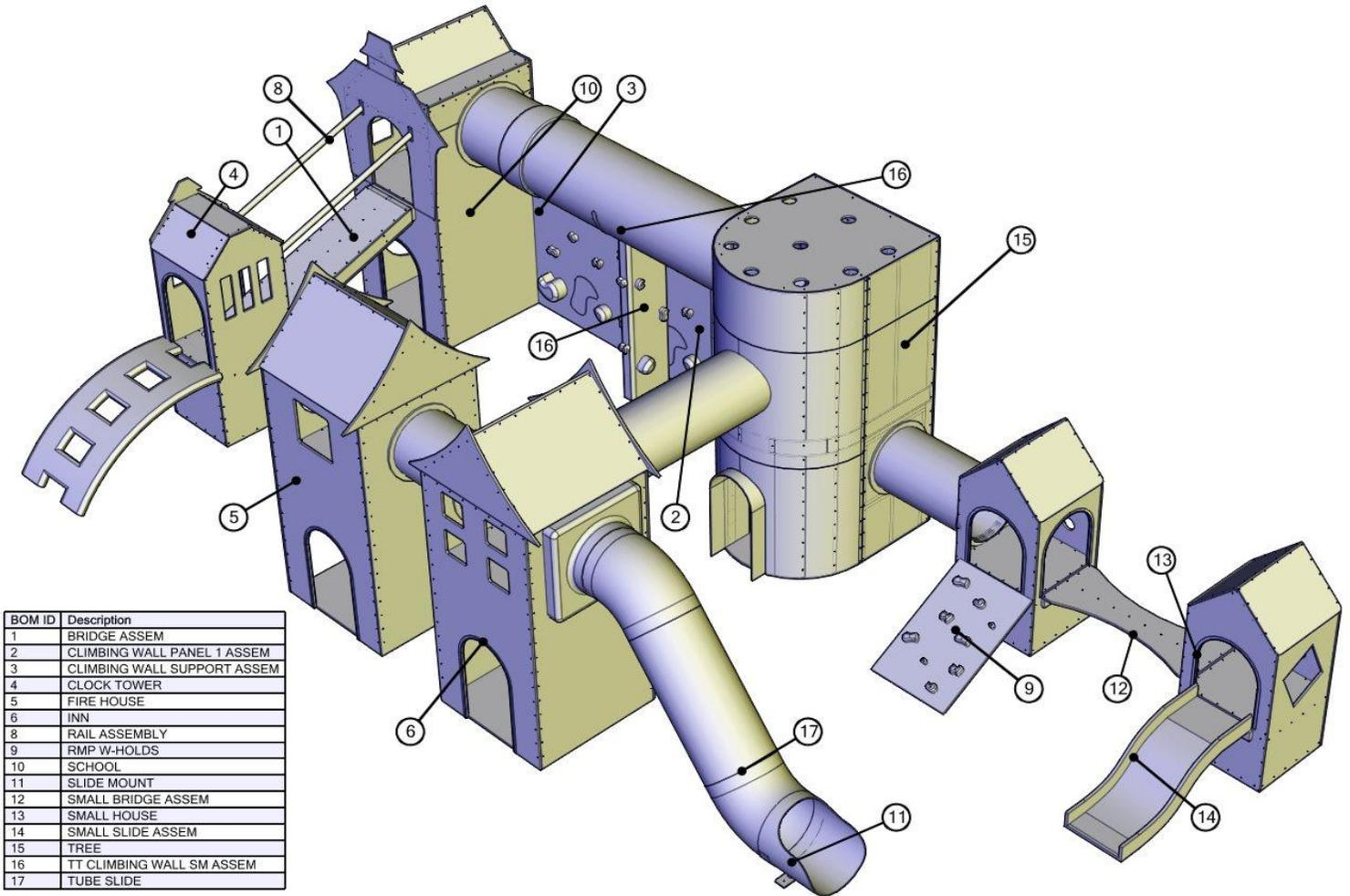

Tumble Town School House

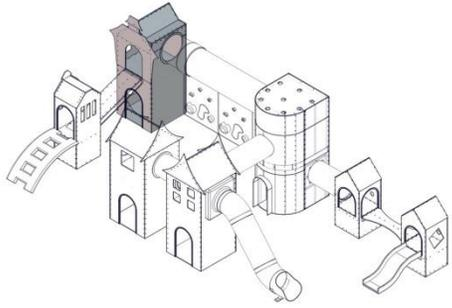

Tumble Town Clock Tower

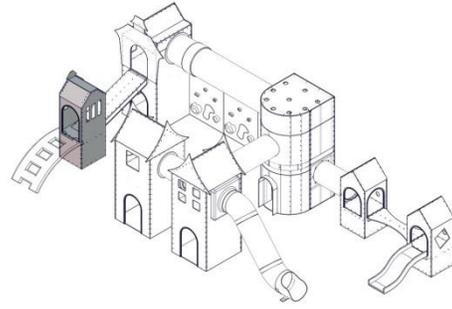

Tumble Town Bridge Assembly

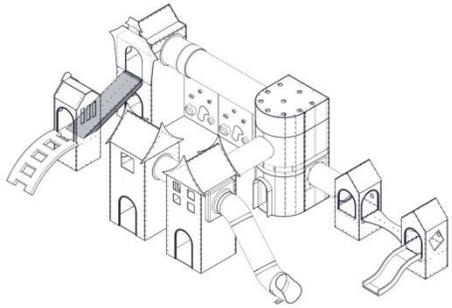

Tumble Town Fire House

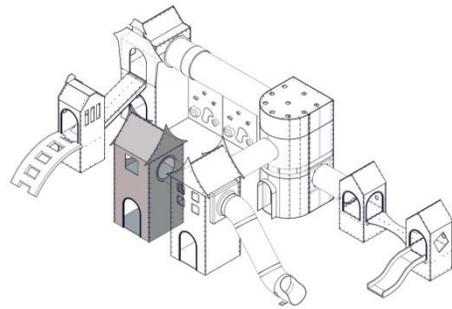

Tumble Town Tree

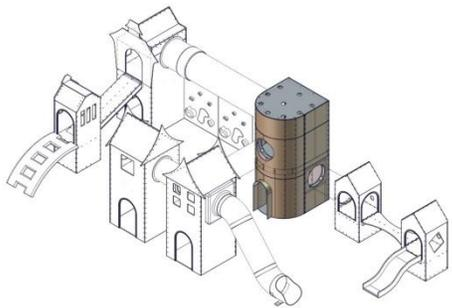

Tumble Town Inn

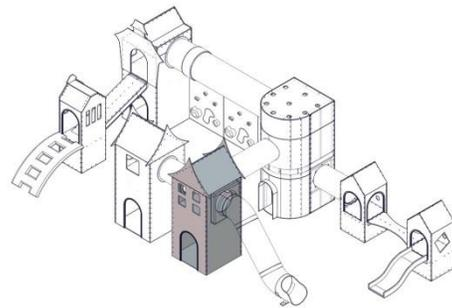

Tumble Town Deli

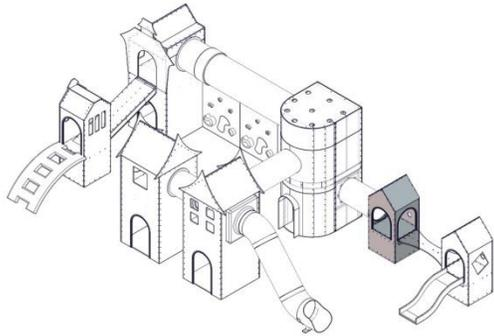

Tumble Town Theater

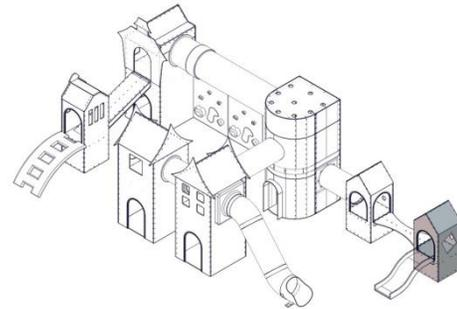

Tumble Town Climbing Wall Frame

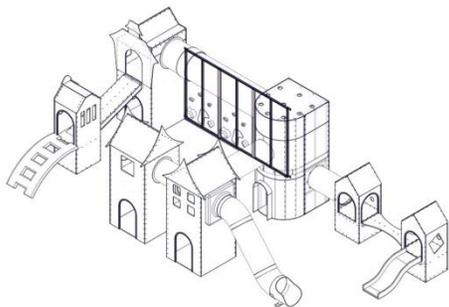

Tumble Town Small Bridge Assembly

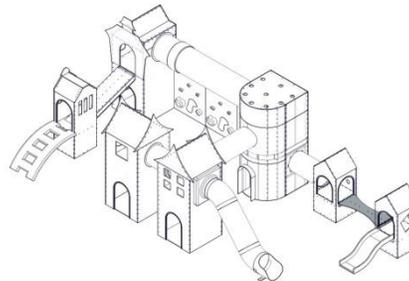

Play Environment

Kidsfit designs every Fitness Obstacle Course to provide a safe and enjoyable play environment for your customers. In addition, a well-maintained fitness obstacle course looks better, lasts longer, and pleases quality-conscious customers.

MAINTAINING THE OPTIMAL PLAY ENVIRONMENT DEPENDS ON:

- a). Implementing a regular, properly conducted and documented inspection and maintenance program.
- b). Staff trained to spot and immediately correct any situation that could compromise the proper function of your Fitness Obstacle Course.

Age Appropriateness and Physical Ability

Kidsfit Fitness Obstacle Courses are designed in accordance with ASTM F 1918-04, for children in the “fifth (5th) percentile two-year old to the 95th percentile twelve year old.” However, Kidsfit recommends providing

a separate toddler area for children three years old and under to prevent injuries that could arise from older children playing in the same area as toddlers.

All children, and especially toddlers, should be supervised at all times while playing in or around the obstacle course. While the fitness obstacle course is intended for children of average ability, children with disabilities or limited mental capacity may require additional adult supervision and assistance.

In most environments, children over the age of 12 should not be permitted to use the obstacle course equipment, unless otherwise intended. Contact Kidsfit for more information.

Kidsfit Warranty Information

Your Kidsfit Fitness Obstacle Course is designed and manufactured to the highest quality standards. If properly used, monitored, and well-maintained, it will provide years of enjoyment for your youngest customers as well as serve as a positive attraction for their parents. We ask that you carefully review your Purchase Agreement for warranty information. If you have specific questions about your warranty, please contact Kidsfit Customer Service at 843.336.5090.

Instructional Signage

Having appropriate signage is an important safety precaution. It is vital to make sure that auxiliary exits are clearly marked and other informational signage is strategically located where it will be seen. Your normal inspection and maintenance activities should include keeping all such signage clean, visible and unobstructed. Post clearly visible informational signage in your facility that communicates capacity levels, age levels, height restrictions and playground hours. Train your staff to fully enforce these policies for the protection and safety of the play area.

*“It is the responsibility of the owner/operator that the exit signs and chevron arrows shall be permanently affixed, plainly visible, and illuminated upon exiting the equipment.
Each exit sign and chevron arrow shall be pointing toward an exit from the building.”
-ASTM F1918-04*

OPERATING A SAFE PLAY ENVIRONMENT

Obstacle Course Safety Summary

Kidsfit is dedicated to offering our customers safe fitness obstacle courses that are designed and manufactured in accordance with the highest industry standards and safety guidelines.

Kidsfit has taken an active role in adhering to the American Society for Testing and Materials (ASTM) Standard Safety Performance Specification for Fitness Obstacle Course Equipment F1918-04.

Operation Guidelines

Operating and offering a safe play environment for your customers takes dedication and a commitment to safety. There are several critical factors to employ in the operation of your play system:

- A well-maintained and clean play system;
- A well-trained staff that is knowledgeable about current contained playground safety guidelines, playgrounds rules and regular playground maintenance;
- A diligent staff that enforces the rules and guidelines for the play area;
- A supervised play environment;
- Appropriate Safety Surfacing;
- A daily, weekly and monthly cleaning & inspection program that is strictly adhered to;
- A commitment to take immediate corrective action when needed; and
- Proper display of signage.

Local Regulations

Kidsfit has outlined several factors critical to making your obstacle course area safe. We also recommend checking state and local laws, regulations and codes that may pertain to operating your play area. Kidsfit is not responsible for compliance with local regulations and codes, as it is the operator's responsibility to ensure compliance.

Fitness Obstacle Course Rules

It is important that all employees are fully aware of your Fitness Obstacle Course rules so that they may be enforced. At a minimum, Kidsfit recommends posting the following rules and cautionary statements. Contact Kidsfit for more information on Fitness Obstacle Course signage.

- **Children must be supervised by a parent or adult at all times in the fitness obstacle course area.**
- **The Fitness Obstacle Course is designed for children ages 3-12.**
- **Please remove shoes, loose articles of clothing and jewelry. Place shoes in Sneaker Keeper® before using the play equipment.**
- **Socks must be worn at all times.**
- **Slide one at a time in a forward seated position, feet first.**
- **Please no climbing on or up the slides.**
- **Please no climbing or standing on the outside of the play equipment.**
- **Please no running.**
- **Please no food, gum or drinks in the play equipment.**
- **Please do not bring toys or other items into the fitness obstacle course.**
- **NOTIFY MANAGEMENT OF ANY PROBLEMS OR CONCERNS**

Staff Training and Responsibilities

It is critical that your staff is properly trained as to the appropriate rules, guidelines, cleaning and maintenance requirements, and operational procedures of your Fitness Obstacle Course Equipment, and the play area in which it is located. It is important that every staff member understands and enforces the play area rules. It is equally important that your staff is trained to spot and immediately correct any situation that could compromise the proper function of your Obstacle Course System. Staff should be proactive when it comes to finding and correcting maintenance issues before they become problems, and they should be able to identify and order replacement parts. Finally, employees should document inspection and maintenance actions.

Safety Surfacing

Another critical element to providing a safe play environment is installing high-quality, impact absorbing surfacing that complies with ASTM F1292-04, Standard Specification for Impact Attenuation of Surface Systems Under and Around Playground Equipment. Safety surfacing is designed to reduce the occurrence and severity of head injury by absorbing shock and impact during a fall. Surfacing must be provided in areas, use zones and slide use zones immediately adjacent to all accessible parts of the SCPE, as specified in ASTM F1918, Section 9. Dimensions, configuration and fall heights of use zones are defined in ASTM F1918, 9.2-9.5.

KIDSFIT RECOMMENDED SAFETY SURFACING TYPES

Poured-in-Place Surfacing: This rubber surfacing is a combination of recycled tire rubber and colored synthetic rubber mixed with polyurethane resin to bind the materials. Poured-in-Place is mixed on site and trowelled directly onto the playground area in the use zones. The recycled tire rubber is spread out first, providing a foundation and cushion layer. The colored rubber is then trowelled on, allowing for a decorative top coat. The material cures to form a unitary surface. Poured-in-Place surfacing comes in a wide variety of color options and can be customized with a variety of graphics and details.

Prefabricated Tile Surfacing: Tile surfacing is made out of vulcanized rubber or rubber crumb and polyurethane binder, cured and ready-to-use in interlocking tiles. The tiles must be cut to the specifications of your fitness obstacle course equipment. Tiles can be laid out and positioned in accordance with specifications.

SAFETY SURFACING WARNINGS

- Socks should be worn at ALL times.
- Objects that can puncture or tear the safety surfacing should not be worn or used. Examples include high heel shoes, athletic spikes, and ladders.

Alteration of the Obstacle Course and/or Equipment

Kidsfit Fitness Obstacle Courses and Equipment are generally designed and manufactured to adhere to the ASTM Standards, the ADA, and to safe practices within the industry. Your specific fitness obstacle course was carefully designed and configured to be compliant with such standards, laws and practices as well. Any unauthorized alteration of the Fitness Obstacle Course System, its configuration, or any of its components will likely cause the altered item to become non-compliant, and therefore, unsafe. Likewise, any unauthorized change to, adaptation of, or reconfiguration of the Obstacle Course System (including, without limitation, attachment to a non-Kidsfit system or component), will cause the system or component to become unsafe. For these reasons, Kidsfit strictly prohibits the unauthorized alteration of, change to, adaptation of, reconfiguration of, or attachment of your Fitness Obstacle Course System, its configuration or any of its components. Kidsfit is not responsible for any injuries arising out of any such unauthorized action.

Regular Inspections, Cleaning and Maintenance

Regular inspection, cleaning and maintenance programs are an important part of operating a safe play environment. It is YOUR RESPONSIBILITY to implement such programs for your Fitness Obstacle Course Equipment and the overall play area, and to be diligent in enforcing such programs with your staff. Kidsfit recommends adding site-specific inspection, cleaning and maintenance programs to your overall Operations and Maintenance Manual. In the following chapter, Kidsfit outlines inspection, cleaning and maintenance guidelines. Feel free to copy and incorporate these guidelines into your formal Operations Manual.

Spotting and Preventing Misuse

PLAYGROUND MISUSE

Perhaps the most significant threat to the function of your Fitness Obstacle Course System, and to the safety of its users, is misuse. Kidsfit equipment is intended for use in a monitored play environment, where children are supervised by a responsible adult. The CPSC concurs that adult supervision is critical to ensure that children are in the age-appropriate areas, are using the equipment properly, and are within their physical abilities. Proper monitoring by employees should reduce instances of misuse. To prevent misuse of your Fitness Obstacle Course System, employees should be trained in the proper use of all Obstacle Course System components, and instructed to intervene and stop instances of Play System misuse.

PREVENTING MISUSE

- Monitor the number of children playing in the System and evaluate the intensity of play. Overcrowding encourages misuse and abuse.
- Train personnel on rules for your play system including proper use, maximum number of children playing at one time, maintenance and inspection schedules, and general upkeep of equipment.
- Intervene and stop misuse of equipment immediately.
- Children should remove shoes and wear socks before playing in equipment.
- Maintain Rules and Safety Precautions.
- Prevent climbing on the outside of the Play System components or on structural elements.
- Remove children playing in the System without adult supervision.
- Do not allow children to bring foreign objects such as food, drink, toys or other materials into the play system.
- Post and maintain appropriate play area signage outlining Play System rules.

Corrective Action

Corrective Action should be taken when, among other things, you encounter:

- Children playing in the system without socks on their feet.
- Foreign materials and inappropriate objects (including food or drink) in the Fitness Obstacle Course System.
- Children climbing on the outside of the Fitness Obstacle Course System equipment structure, or children that may have gained access to the inaccessible areas.
- Children playing or lingering in front of slide exits.
- Children re-entering or climbing up slides.
- Children in the Fitness Obstacle Course System wearing helmets, loose necklaces, or clothing with drawstrings, loose cords, or hoods, or any other items that may cause entanglement or head entrapment.
- Use of the Obstacle Course Equipment by over- or under-aged (or sized) persons.
- Children playing in the system without adult supervision.
- Components removed from originally installed positions.

- System occupancy exceeding the recommended safe capacity for your Fitness Obstacle Course System or building.
- Loose or missing bolts.
- Torn or frayed netting or webbing.
- Torn floor surfacing or mats.
- Exposed threads.
- Loose or broken parts.
- Pinch Points.
- Sharp or rough edges.
- Chipped, cracked, cut or missing parts.
- Dirt or other inappropriate objects in or around the Play System.
- Misuse of the Play System.
- Foreign objects present in the use zone(s).

If any such problems are encountered, the Fitness Obstacle Course System should be closed or the problem area cordoned off until all necessary repairs, replacements and appropriate remedial measures are completed.

Inaccessible Areas of the Obstacle Course

Your fitness obstacle course system most likely has an area(s) that is intended to be inaccessible by the general public, and especially by children. It is imperative that entrances to such inaccessible areas remain locked and secure at all times, thus preventing children from getting behind, under or crawling on top of the Obstacle Course System equipment or any of its components. **IT IS THE OWNER/OPERATOR'S RESPONSIBILITY TO MAKE SURE THESE AREAS REMAIN INACCESSIBLE.**

Barriers to Prevent Climbing

Barriers are intended to prevent both deliberate and inadvertent access to areas intended to be “inaccessible”, areas deemed to be unsafe, and areas designated for “Authorized Personnel Only.” Kidsfit recommends Fabric No-Climb or Tuff Net® netting on the perimeter of the Play System below 84 inches (213.36cm) to prevent climbing and access to the inaccessible areas.

As a standard practice, climb resistant netting such as No-Climb netting is specified on all units under 84 inches (213.36cm). Fabric No-Climb and Tuff Net® netting are also primarily used on the perimeter of the obstacle course system wherever access gates and plastic molded panels are not employed. Using climb-resistant netting allows for visibility while preventing children from climbing the unit and gaining access to inaccessible areas.

Should your obstacle course system currently contain box netting or other non “climb resistant” netting on the perimeter of the play system under 84 inches (213.36cm), Kidsfit strongly recommends that you replace such netting or material with Fabric No-Climb netting.

For more information, contact Customer Service at 843.336.5090.

Control Access to the Obstacle Course

Access to the Fitness Obstacle Course System should be denied when:

- The facility is closed.
- Maintenance or repair is being performed.
- Problems or hazards are identified at any time.
- Any section or component of the Fitness Obstacle Course System Equipment requires maintenance, repair, and/or replacement.
- A user does not meet the size and/or age usage recommendations.

NOTE: Kidsfit also recommends that you develop an emergency action plan for the occurrence of injury or other emergencies.

Summary of Operating a Safe Play Environment

Operating a safe play environment requires a commitment from management and staff. It is a critical factor in attracting and keeping customers happy and safe with the play area that you provide. Understanding the staff responsibilities, play area rules, and being able to spot and prevent misuse and abuse provides a strong foundation for providing a safe play environment. Just as important are the cleaning and inspection procedures outlined in the next chapter.

A.S.T.M. Definitions and Information

The American Society for Testing and Materials created standard F1918, which outlines Standard Safety Performance Specifications for Soft Contained Play Equipment. The intention of this standard is to reduce the potential for life threatening and debilitating injuries. Kidsfit followed these guidelines in manufacturing your fitness obstacle course system. Many terms used throughout this manual are defined in ASTM F1918. We've included several of these definitions for your information.

THE FOLLOWING TERMS ARE REFERRED TO REPEATEDLY THROUGHOUT THIS OWNER'S MANUAL, AND ARE IMPORTANT TO UNDERSTAND AND KNOW ABOUT YOUR FITNESS OBSTACLE COURSE SYSTEM. TERMS ARE DEFINED AND/OR ADDRESSED BY ASTM F1918 PERTAINING TO SOFT CONTAINED PLAYGROUND EQUIPMENT (SCPE). PLEASE REFER TO ASTM F1918 FOR ADDITIONAL DEFINITIONS AND STANDARDS PERTAINING TO SCPE.

Accessible: Relating to part or portions of the play system that are either (1) capable of being contacted by any body part, or (2) usable by persons with disabilities.

Climber: Any component designed with the purpose of ascending or descending transition.

Component: A part of the play system or any portion thereof that encourages specific activity and does not stand alone.

Designated play surface: Any elevated surface for standing, walking, sitting or climbing; or any flat surface greater than 2.0" (51mm) wide having less than a 30° angle from horizontal.

Emergency access/egress pathway: A clear and unencumbered path that leads directly into or out of the play equipment in a continuous manner.

Entrapment: Entrapments are angles or openings that could entrap or ensnare any part of a child's body and prevent the child from getting free. For equipment, openings and spacing should be larger than 9 inches (22.9 cm) or smaller than 3.5 inches (8.9

cm). For fencing materials, keep openings and spacing smaller than 4 inches (10.2cm). Common entrapments to look out for may include the following:

- Fencing
- Equipment structural supports
- Areas under the equipment
- Spacing between equipment

Entanglement Hazard: Entanglement hazards are situations in which a child's clothes or something around a child's neck could become caught or entwined on a component of a play system or in a gap or spacing created between two adjacent components. Entanglement hazards are of particular concern whenever the play equipment involves motion such as sliding, or when the equipment is in close proximity to other equipment and the child can unintentionally become entangled between the two. Play areas should be free of entanglement hazards. (See Section 6.5 in ASTM F1918-04)

Fall height: The vertical distance between a designated play surface and the protective surfacing beneath it.

Impact attenuation: The ability of a surface system to reduce and dissipate the energy of an impacting body.

Non-use zone: Locked or secured area around or underneath the play system where unauthorized access is not allowed.

Preventative maintenance: A planned program of inspections and maintenance intended to keep equipment functioning properly and forestall equipment failures.

Protective Barrier: An enclosing device that is intended to prevent both inadvertent and deliberate attempts to pass through the device (such as barrier gates and walls).

Pinch, Crush and Shearing Points:

These are areas that can cause unintentional compression (such as crushed or pinched fingers) between the equipment and a body part or between the surface and a body part. Such areas should be restricted and inaccessible to customers. Common areas of concern may include moving, swinging equipment and component connection points. Make sure your play area is free of pinch, crush and shearing points.

Protrusions and Projections: Protrusions are any extensions that could unintentionally contact a child in the play unit. All items in the play unit should be free of protrusions that could cause a potential injury. Common protrusions may include, but not be limited to, the following:

- Protruding handles
- Unpadded edges
- Structural supports
- Exposed nuts/bolts
- Sharp points
- Sharp edges

Projection: A condition that, due to its physical nature, must be tested to requirements of ASTM F1918 to determine whether it is a protrusion or an entanglement hazard or both.

Protrusion: A projection which, when tested in accordance with the requirements of ASTM F1918, is found to be a hazard having the potential to cause serious bodily injury to a user who impacts it.

Sharps Points, Corners, Edges: There should be no sharp points, sharp corners or sharp edges on any playground equipment that could cause a potential injury.

Slide Use Zone: The area immediately adjacent to accessible parts of the slide that is designated for circulation and on the surface of which a user would land when falling from or exiting the slide.

Soft Contained Play Equipment: A play structure made up of one or more components where the user enters a fully enclosed play environment that uses pliable material(s) such as plastic, netting or fabric.

Trip Hazards: All anchoring devices on the play equipment should be installed below the play surface to eliminate trip hazards. Any and all trip hazards should be removed from a play area.

Use Zone: The area immediately adjacent to all external areas of the SCPE that is designated for circulation and on the surface of which a user would land when falling from or exiting the equipment. Use zones should include safety surfacing with sufficient room for children to play without obstructions. Use zones should be maintained around and between all entrances, all exits, slide exits, and the radius around play equipment and play structures. Tables and chairs must not be located in the use zone.

INSPECTING, CLEANING, AND MAINTENANCE

General Information

We cannot overstate how important it is to inspect, clean, and maintain your Fitness Obstacle Course System Equipment. You have made a significant investment and **proper inspection, cleaning and maintenance are now your full responsibility**. As stated earlier, this responsibility is documented by ASTM and CPSC.

Your customers will recognize and appreciate the condition of your facility if you keep the Fitness Obstacle Course area clean and well maintained. In addition, the regular program you establish will greatly extend the life of your equipment.

Your operations standards and common sense dictate the frequency of cleaning the obstacle course system. Remember, the appearance of a clean, well-maintained play environment will appeal to all of your customers and other visitors. For recommended cleaning solutions and procedures, see Appendices A - F.

If any damage or potential hazards are detected, immediately close the Fitness Obstacle Course until such conditions have been corrected. Document your activities on the Inspection & Cleaning Checklists. Employees should become particularly familiar with those sections in this Owner's Manual addressing Components, Replacement Parts, and Repairs. Such illustrated guides will help them better identify problems that may be easily repaired. The guides will also make parts ordering easier and help to assure timely and accurate delivery from our Customer Service Department.

A regular Fitness Obstacle Course System Inspection Schedule should be established based upon the use and environmental factors of your Obstacle Course System. Inspection frequency may vary based upon the intensity of play, ages of the users, number of children playing, amount of adult supervision, etc. The most important element of a successful inspection and maintenance program is attitude. You and your staff must understand the importance of properly maintaining the Obstacle Course Equipment. **A sound preventative maintenance program will reduce accidents in the Obstacle Course System and play area.**

The staff person responsible for inspecting the Obstacle Course System should:

- Be properly trained to identify hazardous conditions.
- Crawl through the Obstacle Course System **BEFORE OPENING EACH DAY** to inspect for debris, loose fasteners, hazardous conditions, etc. All debris and litter should be removed on a daily basis. Kidsfit also recommends crawl-through inspections of the Obstacle Course System before and after events and other gatherings.
- Inspect the Obstacle Course System equipment on a regularly scheduled basis.
- Check your Obstacle Course System Equipment for hazardous conditions. Equipment should be inspected for items such as loose or protruding bolts, missing hardware, damaged equipment, broken parts, tears, etc.

TIP: Photocopy and use the inspection and cleaning checklists in the back of this book. Keep your completed checklists for your records.

General Cleaning Guidelines and Recommendations

Common sense, usage and the environment dictate the frequency of required cleaning of your Obstacle Course System. Kidsfit recommends the following cleaning guidelines² as discussed below. For detailed information, refer to Appendices A - F, which outline cleaning instructions for your Obstacle Course System equipment. At a minimum, Kidsfit recommends cleaning the Obstacle Course System daily. For more thorough cleaning, we also recommend contacting a professional service company that specializes in cleaning and sanitizing Kidsfit Obstacle Course Systems.

Daily Inspections and Daily Cleaning Overview

In general, any soiled areas should be spot-cleaned throughout the day. Cleaning frequency will vary according to several factors, including, without limitation, play area location, amount of use, and monitoring effectiveness. All equipment used by toddlers should be spot cleaned throughout the day on an as-needed basis.

Spot cleaning should be followed by a complete cleaning after closing each day. For more detailed information about cleaning specific components, see “Cleaning Guidelines” in Appendix A.

During daily inspection and cleaning, be sure to crawl through the entire Obstacle Course System. Use the following checklist as a guideline to inspect the obstacle course system. Please remember these checklists serve as a GUIDE only, and are not exhaustive of the cleaning and maintenance that may be necessary for your site based on volume, usage and environment.

Daily Cleaning

Before opening your obstacle course system each day, crawl through and inspect the obstacle course for debris or other items that do not belong in the equipment or play area. Any soiled areas should be spot-cleaned throughout the day. Cleaning frequency will vary according to several factors including, without limitation, location, amount of use, and monitoring effectiveness.

All equipment used should be spot-cleaned throughout the day. Spot cleaning necessity is determined by crawling through the unit. In addition, a unit crawl-through should occur at the close of each business day for inspection and cleaning purposes, and the Obstacle Course System should be completely cleaned. Note: In addition, all Fitness Obstacle Course System Equipment should be inspected daily, prior to opening, as well as before and after special events, birthday parties, etc. For more detailed information about cleaning specific components, see “Cleaning Guidelines” in Appendix A.

Daily Inspections and Daily Cleaning Overview

Below is a Daily Inspections and Daily Cleaning Checklist. When making your inspections, please refer to this sheet to prevent overlooking any items during inspection.

- Remove any inappropriate objects or food in, around, or near the Fitness Obstacle Course that may obstruct clearances. For instance, remove cleaning tools left on the floor near access areas. Be sure to check inside the unit also.
- Make sure there are no loose or missing hardware including, but not limited to, nuts, bolts, rivets or protective cap nuts. Pay special attention to components that are subject to vibration or movement such as a slide.
- Make sure there are no signs of damage or vandalism.
- Make sure there are no broken or missing windows or other polycarbonate (clear plastic) items.
- Make sure that all netting is secure and intact with no holes.
- Make sure there are no missing pieces of post padding and/or plastic ties. Also make sure there are no exposed ends or sharps edges on the ties.
- Make sure the Obstacle Course System equipment is clean. Pay special attention to handrails, stair treads, entrances, windows and other areas that are frequently touched.
- Make sure any mesh fabrics, webbing or vinyls are secure and free from tears.
- Make sure that any floor or component pads are intact, secured and properly located.
- Make sure that tube entry ring pads are intact and secure.
- Make sure there are no pinch points, sharp or rough edges or entanglements on or in the accessible areas of the Obstacle Course System Equipment.

Weekly Cleaning and Inspections

In addition to the daily inspection and cleaning of your Fitness Obstacle Course Equipment, we recommend that additional tasks be performed on a weekly basis. At least once a week, thoroughly clean and inspect the entire play unit. Items to be inspected and cleaned include, but are not limited to, all major components and moving components, windows and domes, junction box pads and other pads, vinyl items and plastic elements.

Weekly Cleaning and Inspections Overview

Below is a Weekly Cleaning and Inspections Checklist. When making your inspections, please refer to this sheet to prevent overlooking anything during the inspection.

- Check all hardware to make sure bolts are tightened, end caps are in place, and all hardware is securely in place. Make sure there is no missing hardware. If missing hardware is found, replace immediately.
- Make sure the support structure is secure with no missing hardware. Be sure to check floor anchoring hardware. If necessary, lift covers to inspect.
- Make sure there are no cracks in plastic elements, windows and domes. Any cracked items should be reported and replaced immediately.
- Inspect vinyl pieces to make sure there are no rips, holes or tears. Monitor signs of wear and replace if necessary. Make sure that web stitching shows no sign of failure.
- Check safety surfacing for potential trip hazards.
- Check netting condition – if overly loose, remove junction covers and tighten

Obstacle Course Maintenance

Maintaining your Fitness Obstacle Course System Equipment to be in optimal condition is critical to the safety and success of your play area. Regular maintenance is to be expected and is important.

Regular maintenance includes replacement of certain parts from time to time such as post padding, netting, and vinyl parts. It also includes making sure nuts, bolts and other hardware is intact, tightened and in good condition. Windows and domes should be free of any gaps; if cracked or broken, windows and domes should be replaced immediately. Steps and/or climb boards should be fastened to the unit and should be free of loose tread and debris.

Necessary maintenance should be identified during regular inspections (which is part of the reason it's so important for your staff to know and be able to identify obstacle course parts).

Periodic “Tune Up”

The procedures outlined in this manual will, in most cases, ensure that your Fitness Obstacle Course System Equipment remains clean and attractive. There may be instances when maintenance by a professional technician is warranted. For assistance at such times, contact Kidsfit Customer Service.

Monthly, Quarterly and Annual Inspections

Many customers have implemented monthly, quarterly and even annual inspections performed by either management and/or outside firms. Regular, documented inspections enable management to keep on top of play area maintenance and prevent costly, unexpected repairs. Contact Kidsfit Customer Service if you would like more information about outside companies that perform regular inspections, maintenance and cleaning programs. Kidsfit recommends implementing these inspections to complement your daily and weekly inspection, cleaning and maintenance regimen.

Static Electricity

What is Static Electricity? Static electricity is generated by the materials in clothing rubbing across the surface of plastic. This is a result of simple physics. It always occurs, but it is worse when humidity is low, which prevents the charge from dissipating into the air. The intensity of the charge depends on three factors:

- a) the relative humidity,
- b) any substances coating the surface, and
- c) the energy of the rubbing.

Your primary area for static buildup will be the slide. To minimize the potential for a strong charge:

- Humidify the air. (This allows the charge to dissipate into the air.)
- Coat the plastic with a material to absorb moisture from the air. (This will allow the charge to flow back into the plastic.)

The recommended material for coating the plastic components is a hypoallergenic liquid fabric softener, diluted with water, dispensed from a spray bottle. Other possibilities are rubbing with a hypoallergenic fabric softener dryer sheet or using an anti-static spray. The diluted liquid fabric softener is probably the most cost-effective method. The coating will wear off in time and will need to be reapplied, especially inside the slide tubes. The time between applications will vary with usage of the unit. Grounding the unit or using insulated hardware will not help. The frame of the unit is already well-grounded. The plastic is a non-conducting material, so it cannot be grounded.

Summary

Simple, routine inspection, cleaning and maintenance will result in a clean, attractive Fitness Obstacle Course System, and extend the life of the equipment and reduce costly repairs. Kidsfit stands ready to answer any question you may have regarding the Fitness Obstacle Course System Equipment. Your Customer Service Representative is only a phone call away at 843.336.5090, Call us:

- When any part is cracked, cut, torn or missing.
- When any component has a worn surface.
- When you are planning a retrofit of your equipment.
- Any time there is a question concerning maintenance.

CLEANING GUIDELINES

<p><i>DOS</i></p> <p>Soap & Water: Mild antibacterial dishwashing soap and warm water are recommended for daily and weekly cleaning. Use approximately 2 tablespoons to one gallon of water.</p> <p>Soft Cloths Clean, absorbent soft cotton cloths such as cloth diapers are best to use on domes, windows and plastics.</p> <p>Soft Bristle Brush Use clean, soft bristle brushes for cleaning ropes and web crawls, and removing dust and debris from plastics.</p> <p>Disinfectant Spray A mild, non-toxic disinfectant spray is recommended for disinfecting plastics.</p> <p>Hand-held Vacuum Cleaner with crevice-reaching attachment Use a hand-held vacuum, as it will serve as a valuable cleaning tool especially for those hard-to-reach areas.</p> <p>WD40 Use WD40 to remove scuffmarks on plastic only. Wash and rinse the surface immediately after using WD40 to remove any WD40 residue.</p>	<p><i>DONTS</i></p> <p>Paper Towels NEVER use paper towels on domes or windows. It will scratch and dull the windows.</p> <p>WD40 NEVER use WD40 on domes or windows.</p> <p>Degreaser NEVER use DEGREASER on any plastics, domes or windows.</p> <p>Harsh Chemicals NEVER use harsh chemicals such as bleach, chlorine, fingernail polish remover, or other chemicals that may degrade or dull the plastics.</p>
---	--

To Clean Plastics, Vinyls and Major Components

Remove any debris. Vacuum excess dust and dirt from the obstacle course system with a hand-held vacuum, when available. Use mild antibacterial soap, a soft cotton cloth and lukewarm water to clean plastics, domes, windows and vinyls. Be sure to wipe entire area clean. Use a clean, soft absorbent cotton cloth to wipe area dry.

Hint: fill a clean plastic spray bottle with mild antibacterial soap and lukewarm water for easier application.

To Clean Domes & Windows

Never use paper towels to clean domes or windows. Kidsfit domes and windows are made of polycarbonate material that will scratch if wiped with materials containing wood fibers such as paper towels. Only use soft, absorbent cotton cloths and a solution of mild dish washing soap and lukewarm water to clean these areas of your Obstacle Course System.

To Remove Spray Paint or Markers from Windows

Wet a soft, absorbent cotton cloth with mineral spirits and wipe off marks. Then use a general-purpose cleaner, such as a solution of mild dishwashing soap and lukewarm water, to clean off any mineral spirit residue.

To Remove Spray Paint or Markers from Vinyls

Apply ordinary hair spray and wipe off marks. Use a general purpose cleaner, such as a solution of mild dish washing soap and lukewarm water, to clean off any hair spray residue. Only use soft, absorbent cotton cloths and a solution of mild dish washing soap and lukewarm water to clean these areas of your Obstacle Course System.

To Remove Scuff Marks from Plastics

Apply WD40 to a soft cotton cloth and wipe. Then use a general-purpose cleaner, such as a solution of mild dish washing soap and lukewarm water to clean off any residue. ***Remember, do not use WD40 on windows or domes!!***

NOTE: When using any cleaning product, be sure to follow the manufacturer's directions. If you have any questions about what to use, contact a Kidsfit Customer Representative by calling 843.336.5090

To Remove Stains from Ropes and Webbing

Use a soft bristle brush and general-purpose cleaner, such as a solution of mild dish washing soap and lukewarm water to remove stains.

To Clean Indoor-Only Activity Centers and Components with Graphics

Use mild antibacterial soap, a soft cotton cloth and lukewarm water to clean toddler panels. Be sure to wipe entire area clean. Use a clean, soft absorbent cotton cloth to wipe area dry. Hint: fill a clean plastic spray bottle with mild antibacterial soap and lukewarm water for easier application. Solvent spirits may be used to clean greasy areas, pen, crayon or other problem areas. **DO NOT USE ABRASIVE CLEANERS.**

To Clean Themeing Elements

To clean themeing elements such as Clubhouse window or fence panels, 3 dimensional custom themeing, graphic banners and signage. Use a soft bristle brush or sponge with mild soap and water. Rinse with clean water. Repeat as needed. **DO NOT USE ABRASIVE CLEANERS OR PETROLEUM BASED SOLVENTS.**

Safety Surfacing

Safety Surfacing is designed to cushion body impact in case of a fall. It is durable and resilient when utilized and maintained in the proper manner.

Safety Surfacing Cleaning and Maintenance

Use only a non-toxic liquid detergent and water solution to clean the surfacing. **DO NOT** use harsh chemicals, petroleum products, bleach, toxins, or acids. These materials, and others, can cause structural deterioration and/or discoloring.

The surfacing needs to be cleaned on a regular basis. The frequency can be affected by number of patrons, activities, and environment among other things. Daily sweeping with a soft nylon brush or vacuuming is suggested for light debris that is not ground in or food related. Outdoor surfacing can be hosed off.

At least weekly, the surfacing should be cleaned with soap and water. To wash the surface, use a non-toxic liquid detergent diluted in warm water. Apply the solution to small areas at a time and scrub with a soft nylon brush. Remove the liquid using a wet vacuum. Be sure to rinse. Always have liquid detergent and warm water available for emergencies and “for a quick clean up”.

Motorized surfacing cleaning equipment is available for purchase from a number of sources. Before buying one of these machines, be sure the seller knows and approves of your intended use on the safety surfacing. Damage caused by improper maintenance procedures or materials is not covered under warranty. For surfacing repairs, contact Kidsfit Customer Service at 843.336.5090 for assistance.

WARNINGS:

- ALL PLAY AREAS SHOULD BE MONITORED.
- SOCKS SHOULD BE WORN AT ALL TIMES.
- OBJECTS THAT CAN PUNCTURE OR TEAR THE SAFETY SURFACING SHOULD NOT BE WORN OR USED. EXAMPLES INCLUDE HIGH HEEL SHOES, SPIKES, AND LADDERS.

INSPECTION AND CLEANING OVERVIEW CHART

ITEM/COMPONENT	CLEANING MATERIAL	CLEANING/INSPECT SCHEDULE	INSPECTION/ CLEANING SUMMARY	NEVER
Plastics, Vinyls & Major Components	<ul style="list-style-type: none"> • Soap & Water solution • Soft Cloths • Mild, Non-toxic disinfectant spray 	<ul style="list-style-type: none"> • Daily • Weekly 	<ul style="list-style-type: none"> • Remove debris • Vacuum excess dust • Wash with soap, lukewarm water • Remove scuff marks with hair spray • Report cracks, tears, holes, etc. immediately 	Never use harsh chemicals, degreaser or hard bristle brushes
Domes & Windows	<ul style="list-style-type: none"> • Soap & Water solution • Soft Cloths 	<ul style="list-style-type: none"> • Daily • Weekly 	<ul style="list-style-type: none"> • Use soap and lukewarm water and soft cloths • Remove spray paint or markers with mineral spirits • Report cracked, broken or missing windows immediately 	Never use paper towels, degreaser or harsh chemicals
Ropes & Webbing	<ul style="list-style-type: none"> • Soap & Water solutions • Soft bristle brush • Mild, non-toxic disinfectant 	<ul style="list-style-type: none"> • Daily • Weekly 	<ul style="list-style-type: none"> • Use soap and water with soft bristle brush to scrub off marks • Spray with mild disinfectant • Report and repair/replace rips, tears and cuts immediately 	Never open a Fitness obstacle course system to the public with ripped, torn or cut netting or webs
Components w/Graphics & Indoor-only Activity Centers	<ul style="list-style-type: none"> • Soap & Water • Soft Cloths 	<ul style="list-style-type: none"> • Daily • Weekly 	<ul style="list-style-type: none"> • Use soap and water with soft, absorbent cotton cloth • Wipe clean and dry immediately • Remove spray paint or markers with mineral spirits 	Never use harsh chemicals, degreaser or hard bristle brushes Never use power washer
Surfacing	<ul style="list-style-type: none"> • Soft nylon brush • Vacuum • Wet vacuum 	<ul style="list-style-type: none"> • Inspect Daily • Inspect Weekly 	<ul style="list-style-type: none"> • Sweep daily with soft nylon brush and/or vacuum light debris that is not ground-in or food related • Outdoor surfacing can be hosed off • At least weekly, the surfacing should be cleaned with soap and water • Use a non-toxic liquid detergent diluted in warm water. Apply the solution to small areas at a time and scrub with a soft nylon brush • Remove the liquid using a wet vacuum. Be sure to rinse. Always have liquid detergent and warm water available for emergencies and “for a quick clean up”. 	Never let food or debris collect on surfacing
Themeing	<ul style="list-style-type: none"> • Soap & Water solution • Soft bristle brush 	<ul style="list-style-type: none"> • As necessary 	<ul style="list-style-type: none"> • Use soap and water with soft bristle brush 	Never use harsh chemicals, degreaser or hard bristle brushes

DAILY CLEANING AND INSPECTION CHECKLIST

TIME PERIOD: _____ to _____

INSPECTED BY: _____ **APPROVED BY:** _____

GOOD CONDITION? Y=Yes N=No	<i>S</i>	<i>M</i>	<i>T</i>	<i>W</i>	<i>T</i>	<i>F</i>	<i>S</i>
OVERALL PLAY AREA: Clean and free of trash, debris, hardware and other inappropriate items? Free of vandalism? Fasteners tight?							
PLASTICS, VINYL & MAJOR COMPONENTS: Clean and free of graffiti, scuff marks, trash and other inappropriate items? Hardware and fasteners tight?							
ACTIVITY CENTERS: Wiped clean with soft cotton cloth?							
DOMES & WINDOWS: Securely in place? Free of gaps, cracks and chips? Free of missing bolts or loose bolts? Clear visibility? Cleaned properly? Needs immediate repair if cracks or fractures of 1/2" (12.77mm) or greater exist between two bolt holes directly adjacent to each other.							
BOLTS, RIVETS, OTHER HARDWARE: In place and secure - not loose (NOTE: Needs immediate repairs if bolt ends extend more than 2 threads beyond face of nut.)							
THEMEING: Securely attached, no pieces, edges or elements broken or chipped.							
CAP NUTS: Secure and in place on entire unit?							
NETTING: Intact and free of rips, cuts, holes, tears? Fastened and attached appropriately?							
UNIT CLEARANCE: Proper use zones are clear with safety surfacing properly installed?							
SURFACING: Use zone free of objects? Clean and swept? Clean and free of odor, debris, food, etc. Cleaned and scrubbed according to guidelines. Any loose, broken or missing surfacing needs to be replaced immediately.							
SIGNAGE: Intact and up to date? Clearly visible when entering play area?							

DAILY CLEANING AND INSPECTION ACTION REPORT

TIME PERIOD: _____ to _____

INSPECTED BY: _____ **APPROVED BY:** _____

<i>DATE</i>	<i>ACTION TAKEN</i>	<i>EMPLOYEE SIGNATURE</i>
_____	_____	_____
_____	_____	_____
_____	_____	_____
_____	_____	_____
_____	_____	_____

WEEKLY CLEANING AND INSPECTION CHECKLIST

TIME PERIOD: _____ to _____

INSPECTED BY: _____ **APPROVED BY:** _____

<u>Cleaning Checklist</u>							
GOOD CONDITION? Y=Yes N=No	<i>S</i>	<i>M</i>	<i>T</i>	<i>W</i>	<i>T</i>	<i>F</i>	<i>S</i>
OVERALL PLAY AREA: Clean and scrubbed with dishwashing soap, lukewarm water and soft cotton cloth towels. All plastics, slides, and climbers cleaned and sanitized? Free of debris and foreign articles?							
WINDOWS AND DOMES: Cleaned with mild dishwashing soap and soft cotton towels?							
SAFETY SURFACING: Clean and free of odor, debris, food, etc. Cleaned and scrubbed according to guidelines. Any loose, broken or missing surfacing needs to be replaced immediately.							
NETTING: Free of dust? Free of cuts, rips, tears, holes?							
PLASTIC TUBES: Free of debris, scuff marks, food and personal items? Clean or remove as needed.							
THEMEING: Free of dust and dirt							

<u>Inspection Checklist</u>							
OVERALL PLAY AREA: Clean and free of sharp edges, pinch, shear and crush points							
SLIDES: Free of cracks, warps, gaps greater than 3/16" between connecting plastics? All nuts and caps secure, in place and tight?							
PLASTICS, VINYLs AND MAJOR COMPONENTS: Free of cracks, hardware intact and tight?							
COMPONENTS: Free of cracks, warps, gaps greater than 3/16" between connecting plastics?							
THEMEING: Secure attached? Free of cracks, chips or burrs?							
DOMES AND WINDOWS: Securely in place. Free of gaps, cracks and chips. Free of missing bolts or loose bolts. Clear visibility. Cleaned properly. Needs immediate repair if cracks or fractures of 1/2" (12.77mm) or greater exist between two bolt holes directly adjacent to each other							
BOLTS, RIVETS, OTHER HARDWARE: In place and secure – not loose. If nuts are missing, replace immediately and tighten securely. Check replaced nuts following week to confirm tight. (Note: needs immediate repairs if bolt ends extend more than 2 threads beyond face of unit.)							
NETTING: Intact and free of rips, cuts, holes, tears? Repair immediately.							
UNIT CLEARANCES: Proper use zones are clear with safety surfacing properly installed							
ANCHORING/ SUPPORTS: In good condition, free of damaged, broken parts cracked, chipped or peeling paint.							
SIGNAGE: Intact and up to date? Clearly visibly when entering play area?							

SAFETY SURFACING: Clear of seating and décor? Poured-in-place or tiled surfacing has a minimum of 2” (51mm) in depth. Free from gaps or trip hazards, clean and free of odor, debris, food, etc. Free of curling on edges? Any loose, broken or missing surfacing needs to be replaced immediately.							
OTHER: Unit is free of pinch or crush points, entanglements and protrusions.							

WEEKLY CLEANING AND INSPECTION ACTION REPORT

TIME PERIOD: _____ to _____ INSPECTED BY: _____ APPROVED BY: _____		
<i>DATE</i> _____ _____ _____ _____ _____	<i>ACTION TAKEN</i> _____ _____ _____ _____ _____	<i>EMPLOYEE SIGNATURE</i> _____ _____ _____ _____ _____

ANNUAL CLEANING AND INSPECTION CHECKLIST

TIME PERIOD: _____ to _____
INSPECTED BY: _____ **APPROVED BY:** _____

<u>Cleaning Checklist</u>	
GOOD CONDITION? Y=Yes N=No	DATE
SCREWS, NUTS, BOLTS, RIVETS: In place, tight and secure. (NOTE: Needs immediate repairs if bolt ends extend more than 2 threads beyond face of nut.)	
NETTING: Free of rips, tears, cuts. Properly installed without exposed edges	
PADS: Free from holes, tears and other damage?	
SLIDE RUNOUTS/ ENTRYWAYS: Stable and free of debris?	

<u>Inspection Checklist</u>	
SLIDES: Free of gaps greater than 3/16". Bolts are non-protruding. Free of obvious surface imperfections.	
DOMES AND WINDOWS: Securely in place. Free of gaps, cracks and chips. Free of missing bolts or loose bolts. Clear visibility. Needs immediate repair if cracks or fractures of 1/2" (12.77) or greater exist between two bolt holes directly adjacent to each other.	
CRAWL TUBES: Free of gaps in seams greater than 5/8" (16mm). Loose bolts or obvious surface imperfections?	
SNEAKER KEEPER: Free of debris. Securely affixed to unit or ground. Signage intact. Bolts are capped.	
SIGNAGE: All signage intact and placed for easy visibility. Signs readable, clean and free of damage or vandalism. Securely placed or affixed to unit.	
SAFETY SURFACING: Clear of seating and décor. Pour-in-place or tiled surfacing has a minimum of 2" (51mm) in depth. Free from gaps or trip hazards. Clean and free of odor, debris, food, etc. Free of curling on edges. Any loose, broken or missing surfacing needs to be replaced immediately. Minimum of 5 feet (1525mm) of safety surfacing around use zones, entrances and exits of the Obstacle Course.	

ANNUAL CLEANING AND INSPECTION ACTION REPORT

TIME PERIOD: _____ to _____ INSPECTED BY: _____ APPROVED BY: _____		
DATE	ACTION TAKEN	EMPLOYEE SIGNATURE
_____	_____	_____
_____	_____	_____
_____	_____	_____
_____	_____	_____
_____	_____	_____

