

119-15.

Boosey's Iron and Brass Drainage Specialties

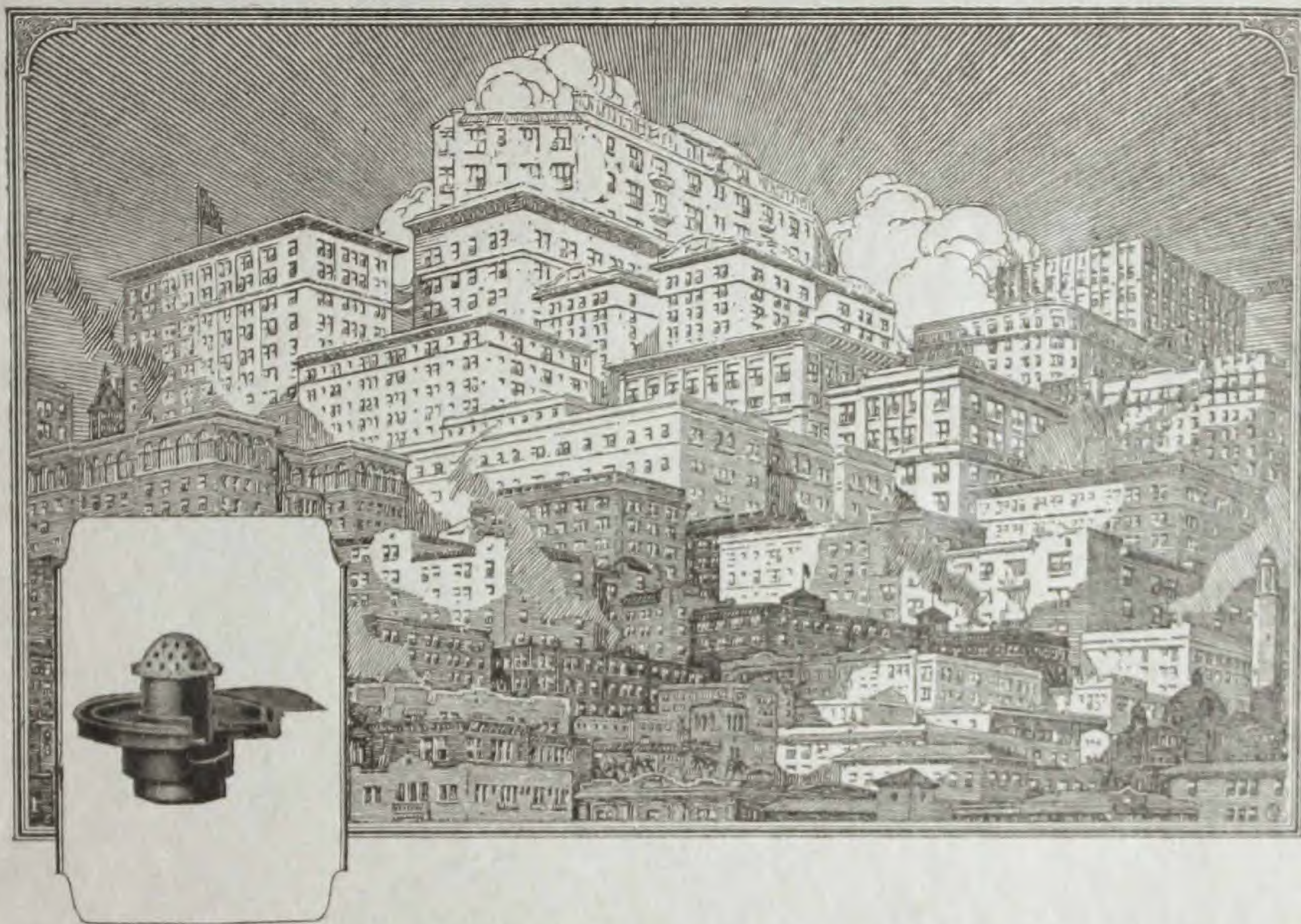

Manufactured by

Greenwood Manufacturing Co.

5140 Hamilton Avenue

Detroit, Michigan, U. S. A.

Catalogue
Number

24

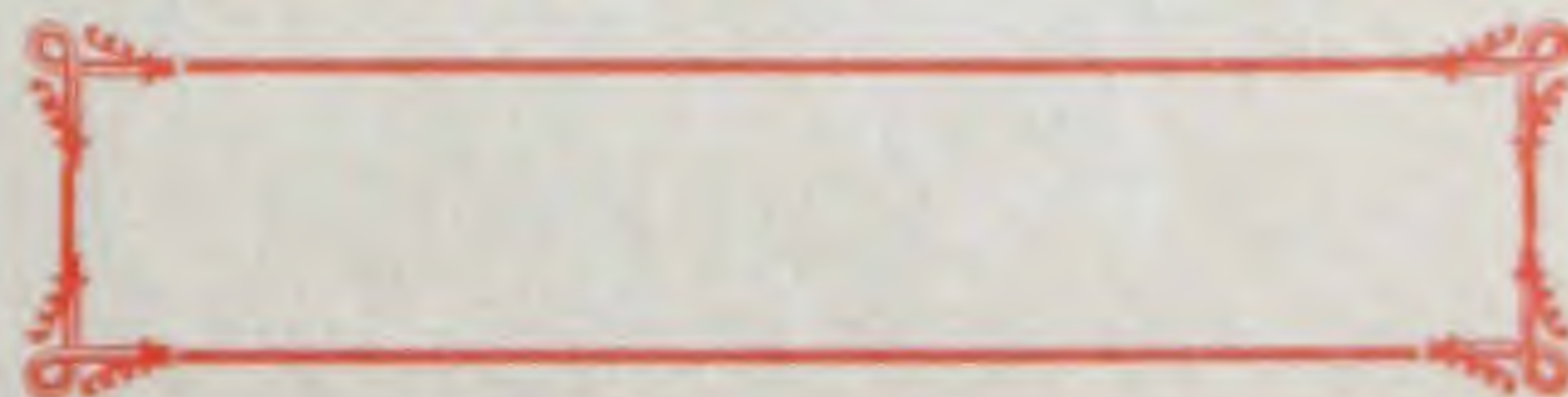

[BLANK PAGE]



CCA

SUPPLEMENT No. 7

CATALOGUE No. 24

PATENTED DRAINAGE SPECIALTIES

Basement and Roof Drains

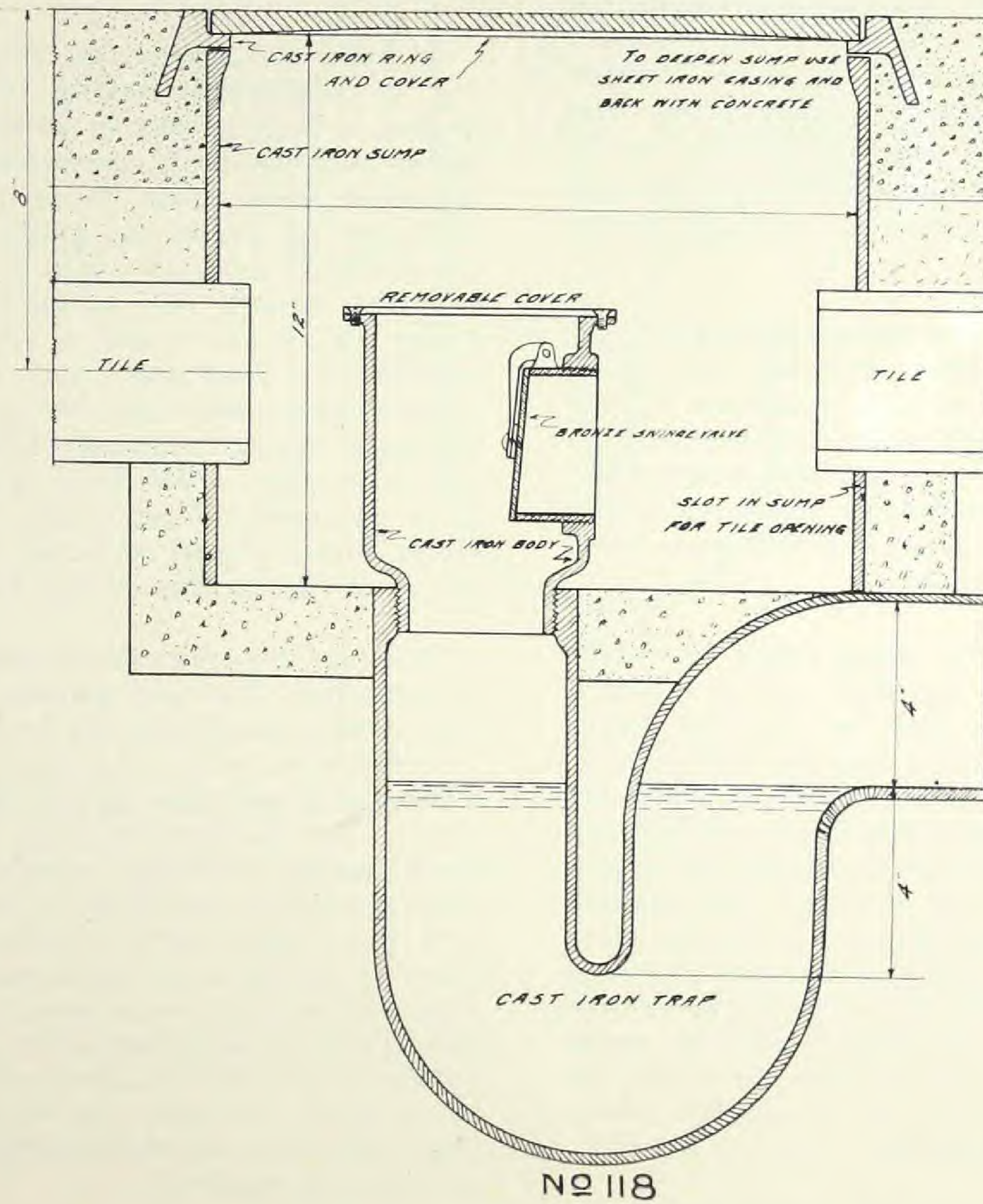

GREENWOOD MANUFACTURING CO.
DETROIT, MICHIGAN

Back Water and Flooded Basements

All fast growing cities face the same problem. Subdivisions one after another are added to the sewage system until miles of territory are drained through the underground sewers, and heavy showers overtax the capacity of these sewers. When this happens, house, store and factory drainage that had always proved satisfactory suddenly fails to operate and thousands of dollars in damage is the result.

Why this wide spread damage? Because the system installed was never intended to resist back pressure. Crock drains were used under basement floors for conductor lines and tile drains were connected to conductor lines with only an intercepting trap, and bell traps were used for floor drains.

The reason for using crock for inside drainage is the low first cost of material and installation, and the fact that under ordinary conditions they are satisfactory. But when the water backs up from the main sewers the result is one awful muss. Sewage backs through all the tile drains and is distributed through the cinders under the cement floors, and as the water rises it pours out through the openings in the cemented hubs and broken crock and through bell traps, with the result that within a few minutes there may be several inches or feet of sewage waste flooding the basement.

Under these conditions it is reasonable to assume, that during heavy rains where crocks have been used for drainage or where tile drains have been connected

through intercepting traps to the rain water drains or where bell traps have been used for basement drains, crock drains are a liability.

In order to prevent the constant flooding of basements having inside crock drains, it is necessary to change the rain water and tile drain connections, remove all crock from under floors, and replace with iron to above the grade line. The tile drains should drain into an iron sump and out through an accessible vertical swing check valve with a screwed connection to a deep seal 4 inch trap with a 4 inch water seal, and be connected to drainage system through 4 inch X. H. cast iron pipe. All floor drains should have accessible brass swing check back water valves placed on house side of trap above the water line of trap seal.

The two drawings show floor drainage construction that will prevent the flooding of basements and are both approved by the Detroit plumbing department, and show the proper placing and detail drawings of the Greenwood Mfg. Company's back water drainage specialties that, when installed according to instructions, will give satisfactory results. Only in case of carelessness such as filling the floor drains with rags, soap, coal, ashes and sticks, or emptying paint, paste, kalsomine or cement into them, will they fail to operate, and then the owner can at least tell where the water is coming from and have it repaired.

Look for the name Greenwood Mfg. Co.; it stands for the highest grade of drainage specialties.—Norman Boosey.

Back Water Tile Drain Sump

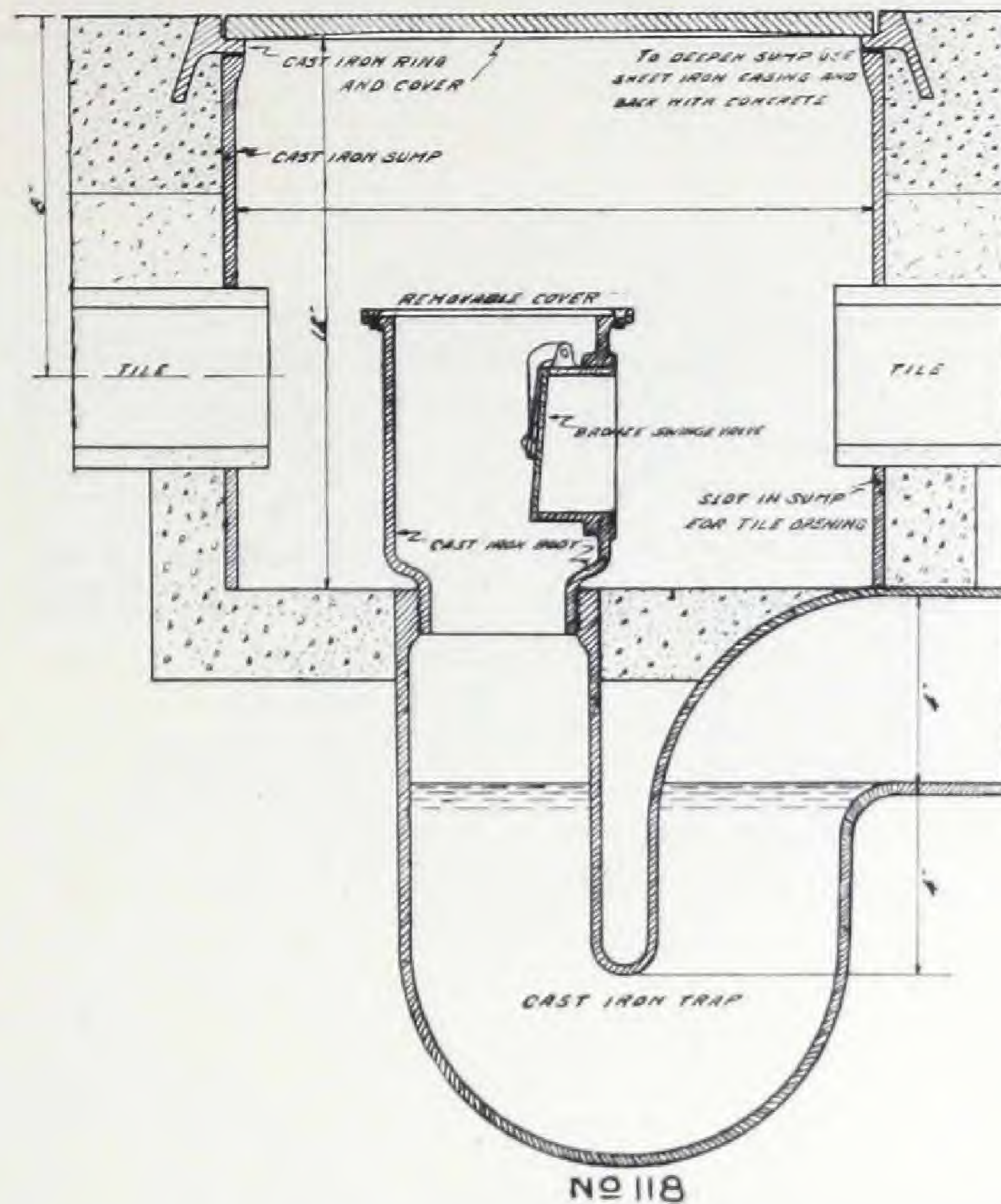

Manufactured by the Greenwood Manufacturing Co. Consists of a removable $12\frac{1}{2}$ " iron cover fitted to a 15" outside diameter cast iron ring with flanged sides for anchoring into concrete floor—the ring fits over the cast iron sump 14" in diameter and 12" deep with two slotted openings for three-inch field tile.

The sump is provided with a four-inch cast iron P trap with four-inch water seal and screwed to trap inlet is a four-inch swing check valve that in event of back pressure from floods or any other cause will prevent the flooding of basement through the tile drains.

The trap connects to the drainage system through four-inch X. H. cast iron pipe.

Back Water Floor Drain

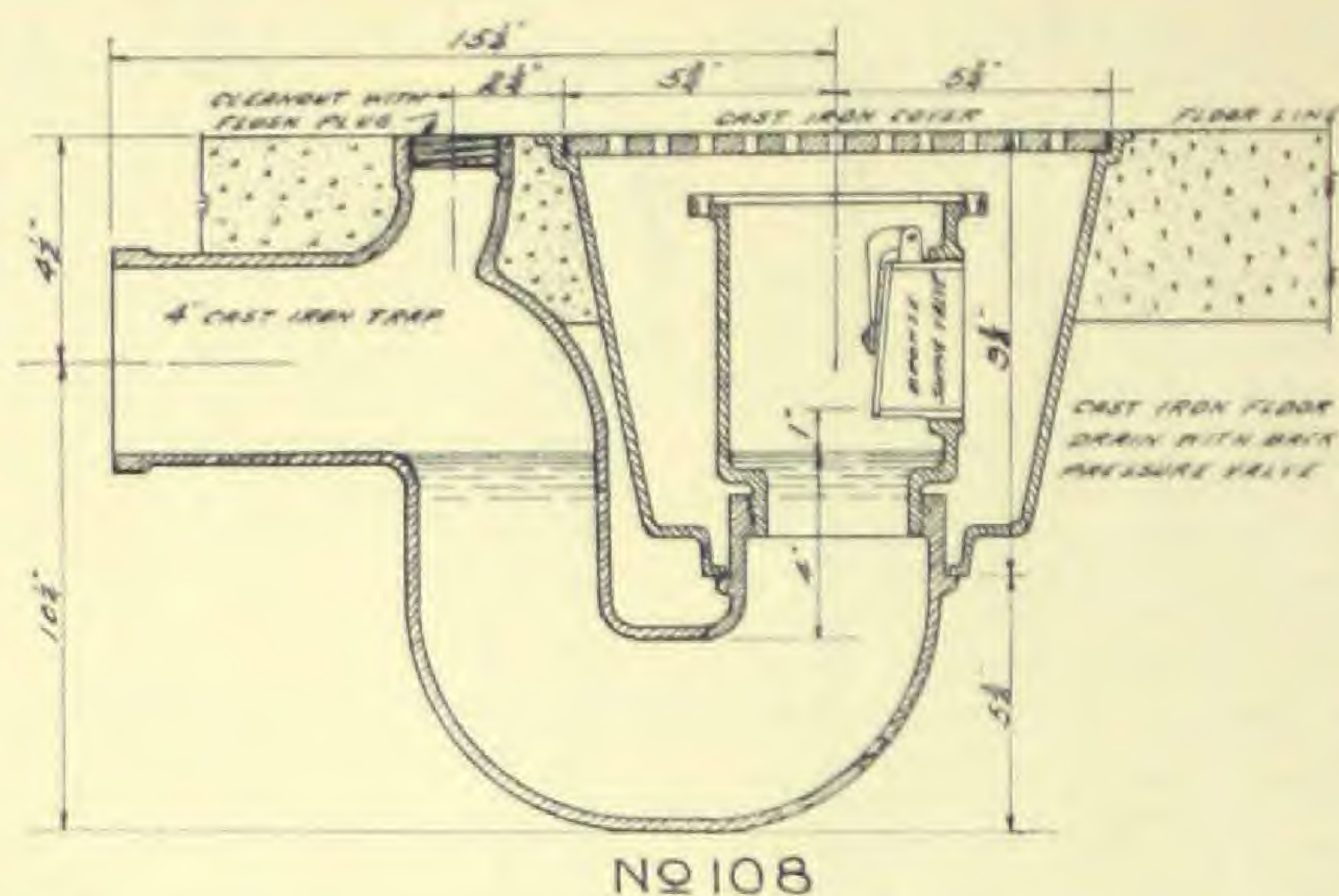

No 108 is made in three sizes, 2, 3 and 4 inch.

The four-inch size consists of a 12-inch perforated strainer fitted to cast iron receptor, size 12"x9", fitted with a four-inch bronze swing check valve screwed to a four-inch cast iron trap with cleanout.

This drain offers the same protection against back water as described in the Sump fitting.

Note that all parts are easily accessible. The swing check valve is above the water in the trap seal and is placed just below the perforated cover on the inlet side of trap where it is the most accessible for cleaning or inspection.

Combination Iron and Crock Drainage

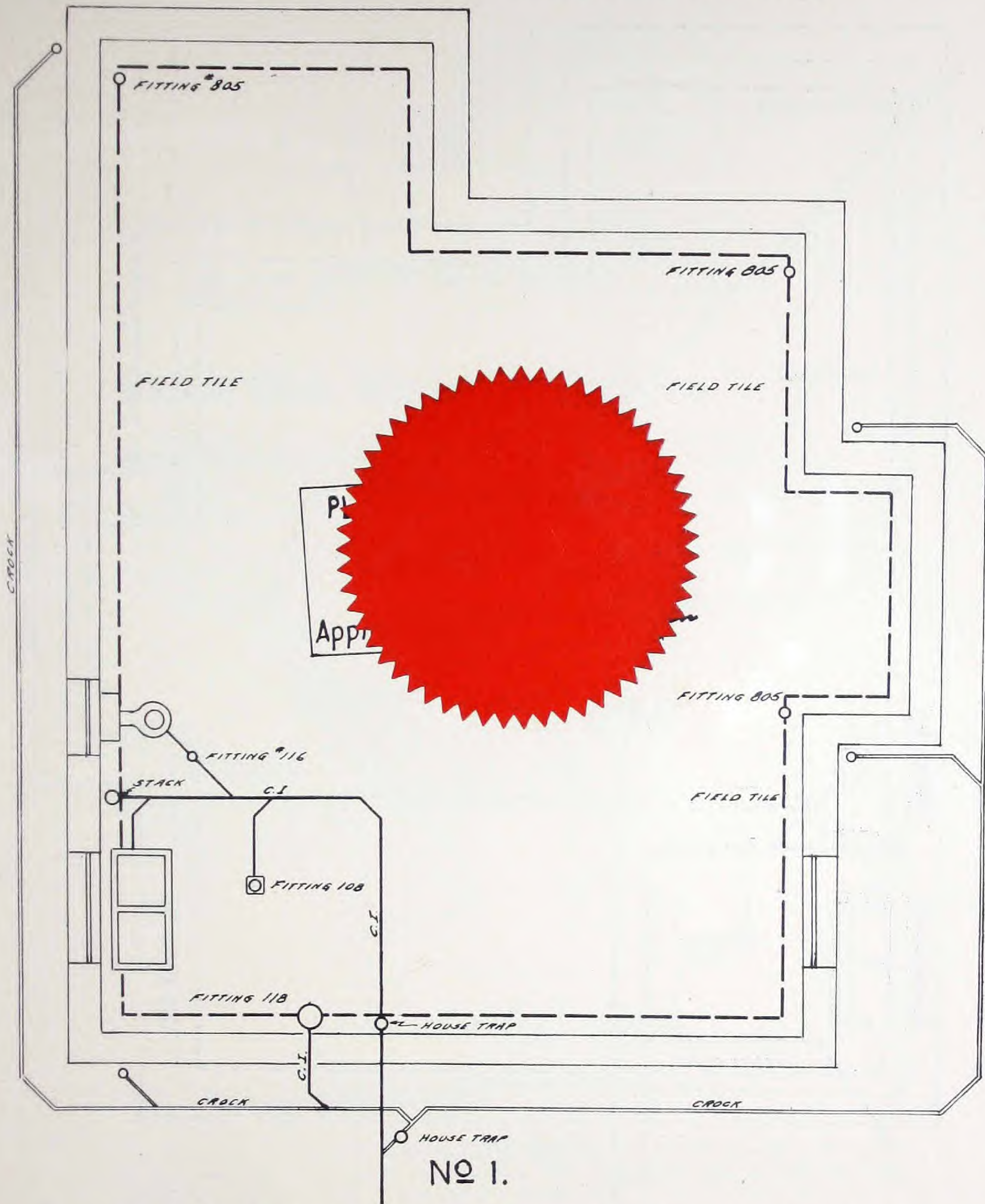

Describes a system of drainage using iron drains under basement floor for soil waste, and crocks outside basement wall for rain water.

This system will prevent the flooding of basements but is economical to install only when conductors are near house-trap. The crock rainwater lines should be laid at least two feet outside the basement wall, therefore the cost of additional digging generally is more than the difference between the cost of iron and crock installation. Where house traps are required, the one on the rain water line is placed outside the basement wall and should it become clogged with pieces of shingle, leaves and twigs or roots from shrubbery planted around wall, it is generally necessary to dig it up at considerable expense and inconvenience.

Where crocks are used for soil drainage—there are other than sanitary reasons for doing it.

All Iron Drainage

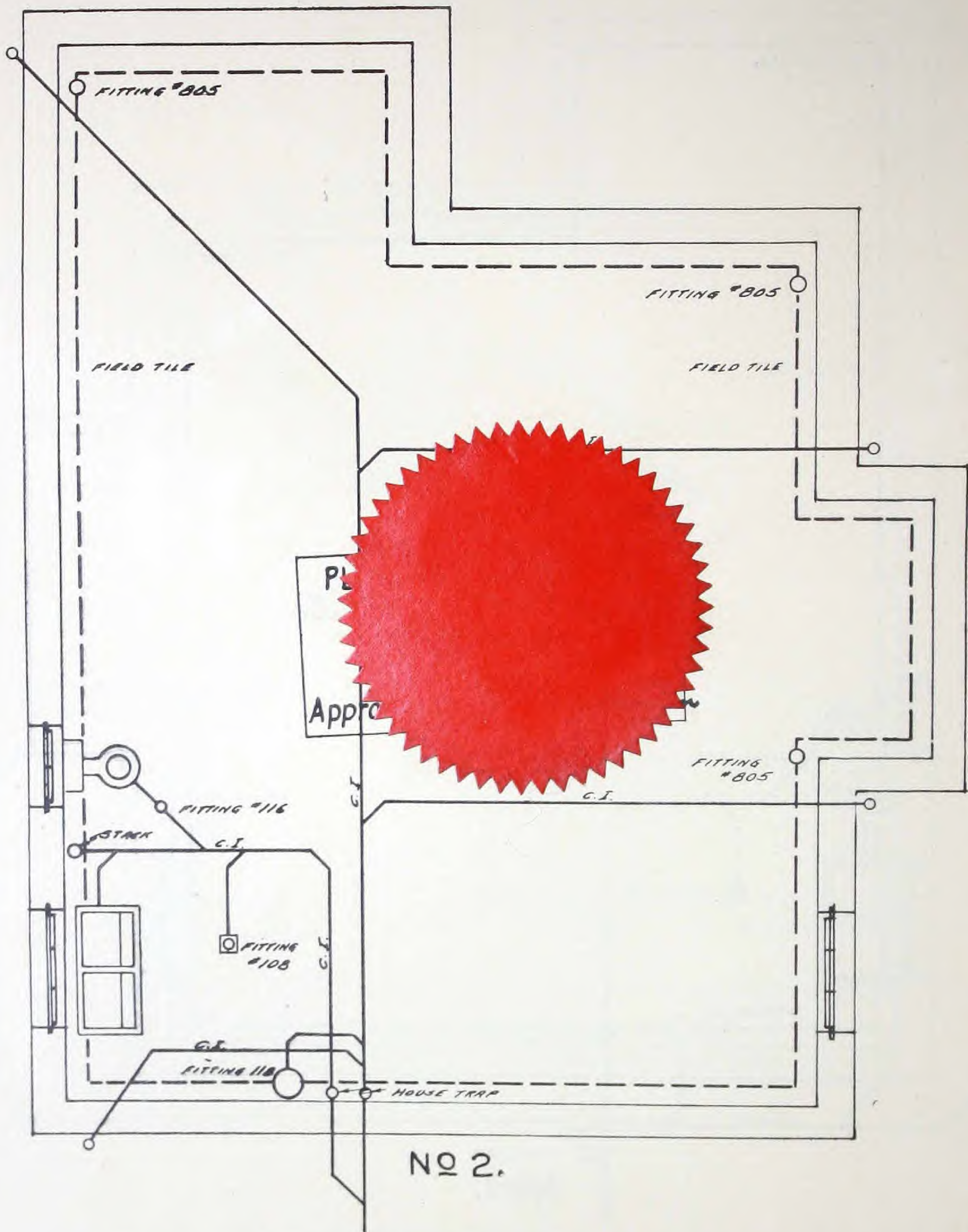

Describes an economical all iron system of drainage construction that will prevent the flooding of basements. It may be used in any locality, either with or without house traps, according to the applied code. The rain water and sewage waste lines run under basement floor are cast iron and separate units that may be joined together five feet outside basement wall or run separate to soil and storm water sewer. In all cases the cast iron rain water lines should extend above the grade line. Cracked walls can generally be traced to crotch rain water connections where they pass through basement foundation walls.

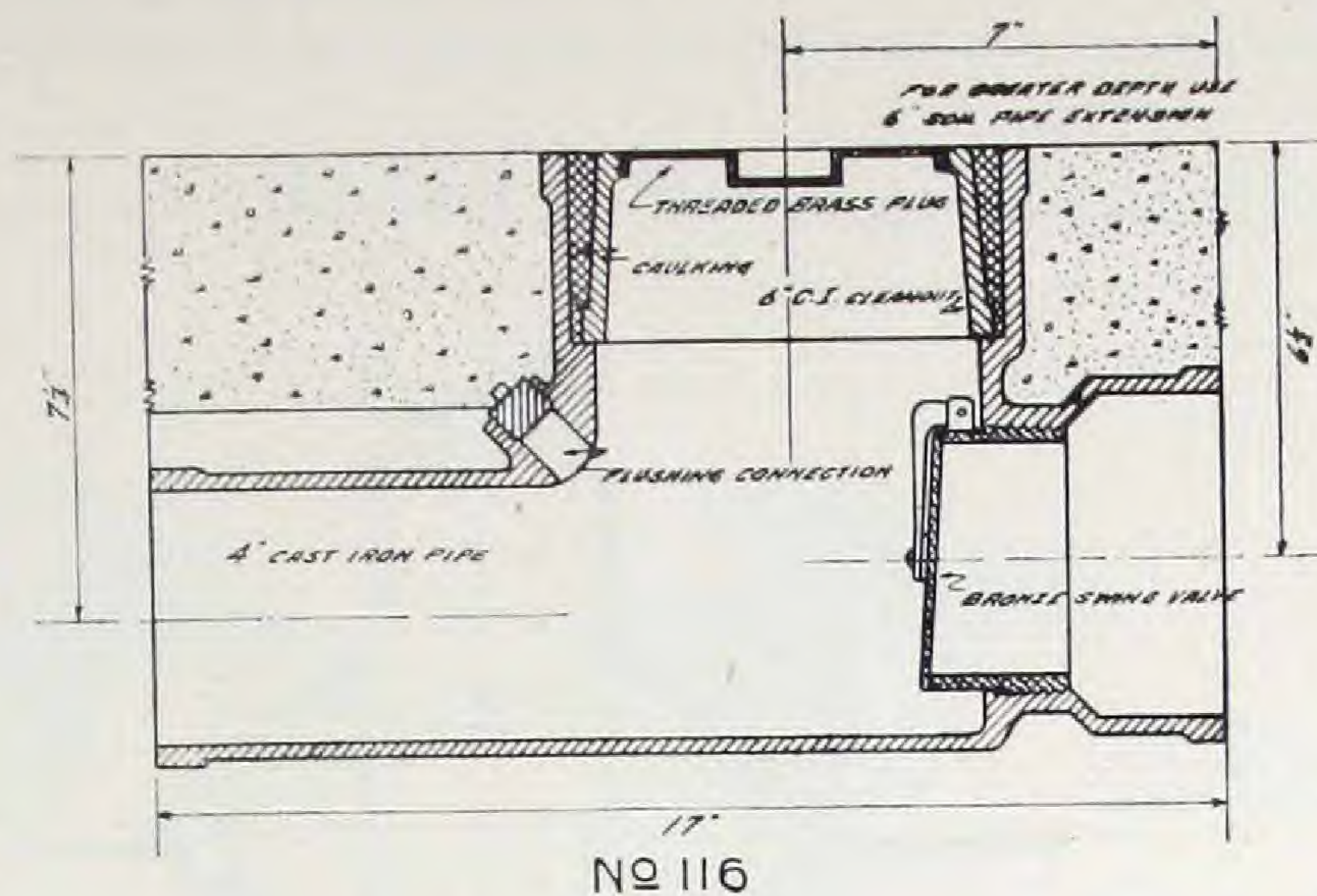

Visible Back Water Check Valve

Fitting No. 116 is described as a horizontal accessible swing check valve. It is designed for protection to basement closets against flooding due to back pressure.

The cross section shows a six-inch threaded brass clean-out which is easily removable for inspection or cleaning.

The bronze check valve has a one-inch drop from valve lip, making the valve easy to operate and self-cleaning.

We recommend that they be placed as close to the closet as convenient.

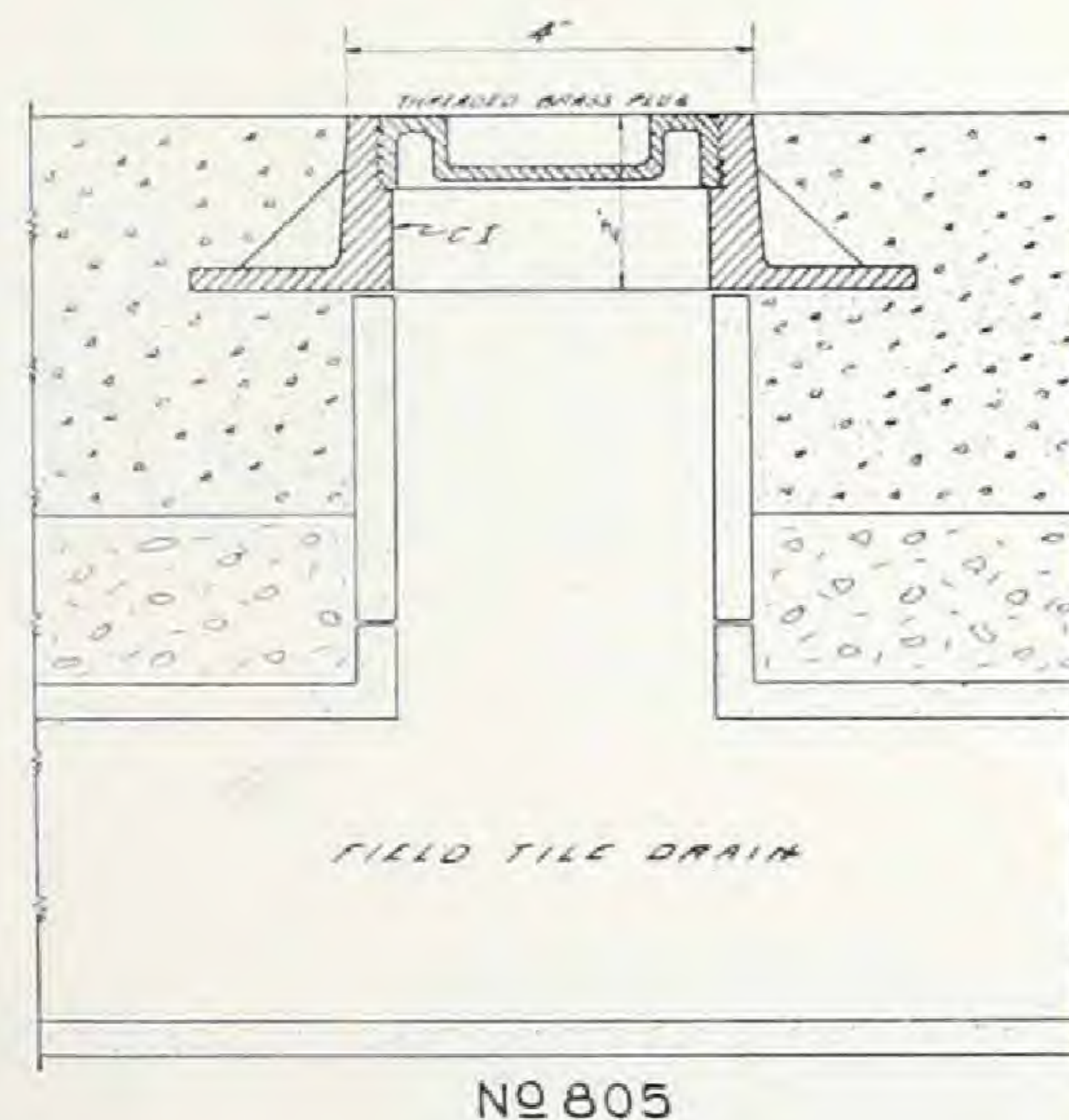

Tile Drain Cleanout

Consists of a cast iron body tapped 3" iron pipe size and fitted with a 3" counter sunk brass plug. The casting has a flanged base with angle stays to body, the stays holding the cleanout body securely in the cement floor.

The writer for years worked as a plumber in all parts of the country and many times has found it necessary to break up cement floors in several places just to locate the stoppage in the tile drains that was causing the basement to be damp and musty.

If suitable cleanouts had been installed, they would have saved the owner considerable money for plumbers' time and patching the floor.

Iron Roof Sumps

The cross-section shows the construction of the Greenwood Manufacturing Co. roof sump and method of installing same in roof.

This sump is so constructed that the total amount of inlet openings far exceed the outlet area of the down spout with the added feature of height above the roof that prevents the inlets from becoming clogged by leaves or other materials that would tend to clog a lower sump strainer. The inner and outer strainers are easily removed by unscrewing three brass nuts.

Advantages that appeal to the contractor are that the sumps can be placed any time after the roof is complete. The plumber connects sump to the down spout line by removing the guards and calking the hub of sump to down spout.

The roofing contractor may make all necessary connections before or after the plumbing work is done by removing three nuts that hold the binder ring in place and turning the roofing fabric over the rounded edge of sump frame and replacing the binder ring and nuts.

Copper flashings and expansion joints are optional. This sump is made of cast iron or brass with the bottom strainer grate in the five and six-inch type only.

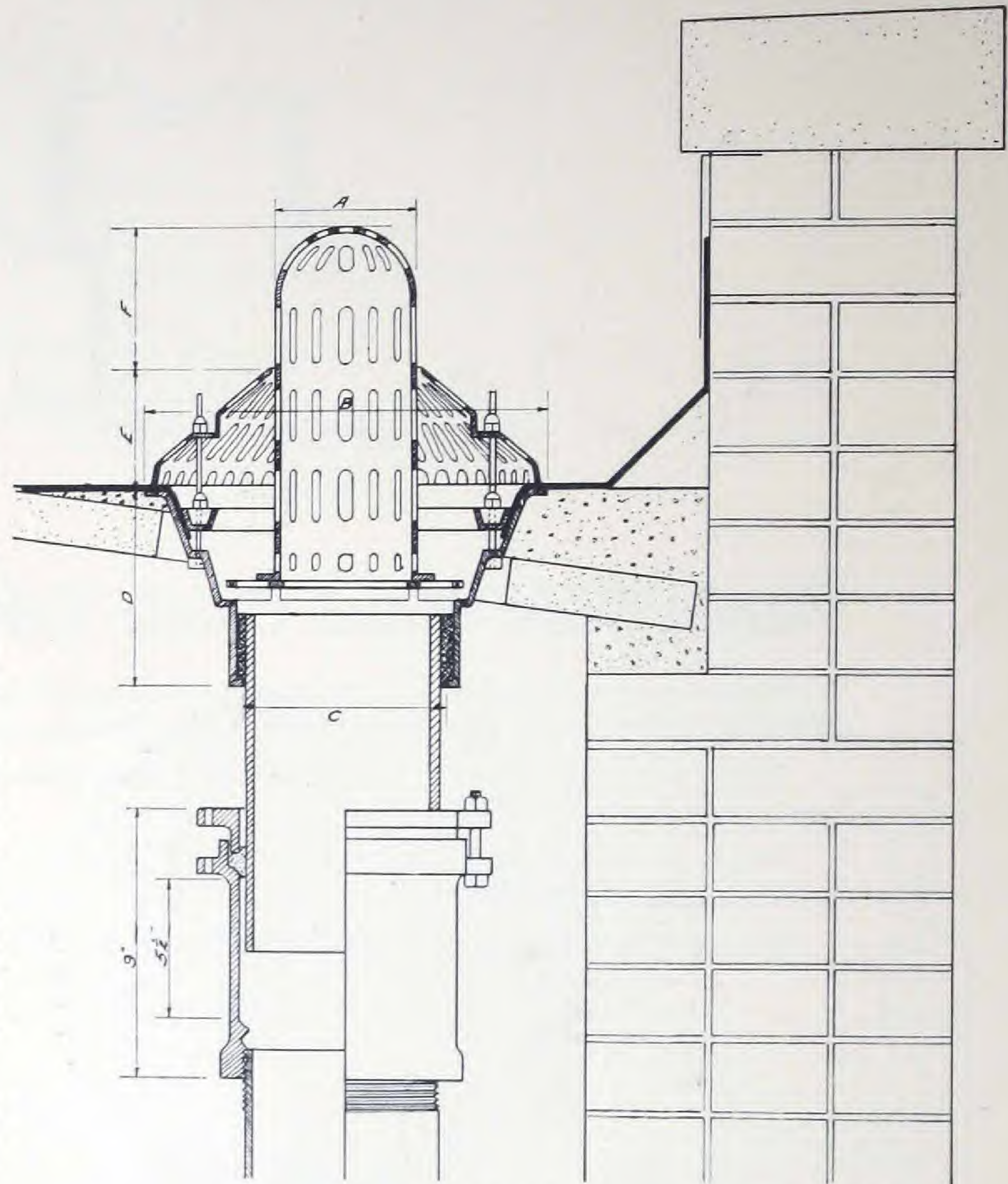

PIPE SIZE	FITTING NO 140						NO 165	
	A	B	C	D	E	F	LIST	REMARKS
3	4 1/2	11	3 3/4	6 1/4	4	4 3/4	16 ⁰⁰	EXPANSION FITTING
4	4 1/2	11	4 3/4	6 3/4	4	4 3/4	16 ⁰⁰	FOR ALL SIZES IS
5	4 1/2	13 1/2	5 3/4	6 1/2	4	4 1/2	22 ⁰⁰	EXTRA OVER LIST
6	4 1/2	13 1/2	6 3/4	6 1/2	4	4 1/2	22 ⁰⁰	PRICE SHOWN

Roof Flange

Cast Iron Roof Flange shown has the same advantage as outlined in the Greenwood Manufacturing Co. roof sump, in that the flange is calked to vent stack and connections by plumber and roofer are entirely independent operations.

This flange is for use on all types of flat roofs and is supplied for pipe sizes from three to six inches in diameter.

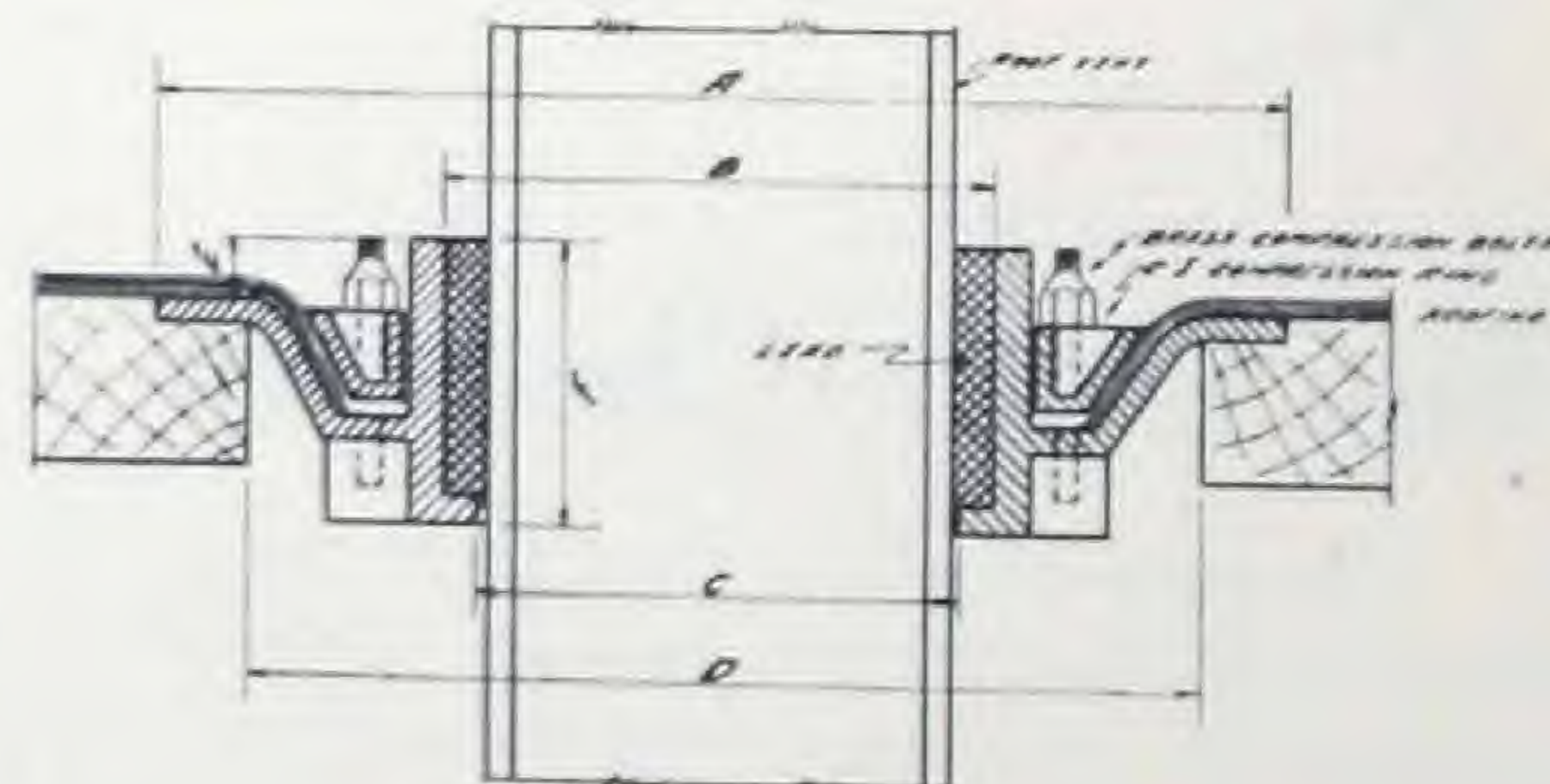

NO 145						
PIPE SIZE	A	B	C	D	E	F
3	11	15	15	2	5	15
4	11	15	15	2	5	15
5	11	15	15	2	5	15
6	11	15	15	2	5	15

GREENWOOD MFG. CO.

DETROIT, MICH.

Boosey's Seepage Floor Drains

(Patented)



No. 131

Washroom Floor Drain Head

Outlet tapped 3 inch.
Diameter of strainer 9 inches.
Diameter of seepage flange 11 inches.
Depth of head 4 1/2 inches.



No. 130

Shower Drain Head

Outlet tapped 2 or 3 inch.
Furnished with lead pan connection.
Adjustable 5 1/2-inch N. P. brass strainer.
Diameter of seepage flange 9 and 11 inches.
Depth of head 4 1/2 inches.



No. 132

Washroom Floor Drain Head

Outlet tapped 3 inch.
Nine-inch brass top with hinged strainer.
Diameter of seepage flange 11 inches.
Depth of head 4 1/2 inches.



No. 133—Female

Shower Drain Head

Outlet tapped 2 or 3-inch female.
Adjustable 5 1/2-inch N. P. brass strainer.
Diameter of seepage flange 9 inches.
Depth of head 4 inches.

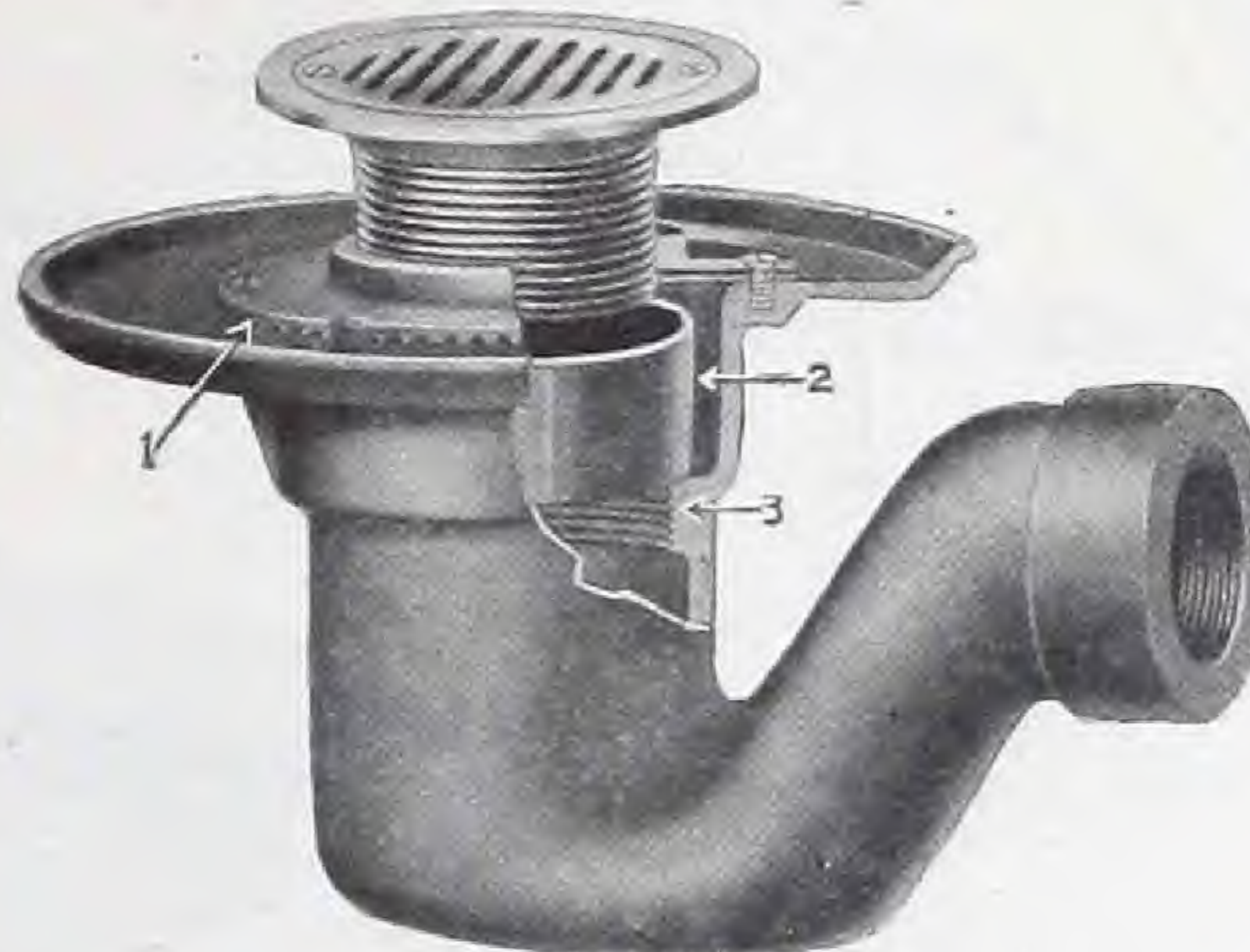

No. 126-130

Shower Trap

No. 1—Shows the protected seepage openings.
No. 2—Hub recess. The lead pan is secured to trap body with a calked joint assuring a positive and permanent water tight connection.
No. 3—Trap body tapped for iron plug makes testing easy.
Outlet tapped 2 or 3 inch.
Lead pan connection.
Adjustable 5 1/2-inch N. P. brass strainer.
Diameter of seepage flange 11 inches.
Depth of trap body 7 inches.



No. 133—Male

Shower Drain Head

Outlet threaded 2-inch male.
Adjustable 5 1/2-inch N. P. brass strainer.
Diameter of seepage flange 9 inches.
Depth of head 4 inches.

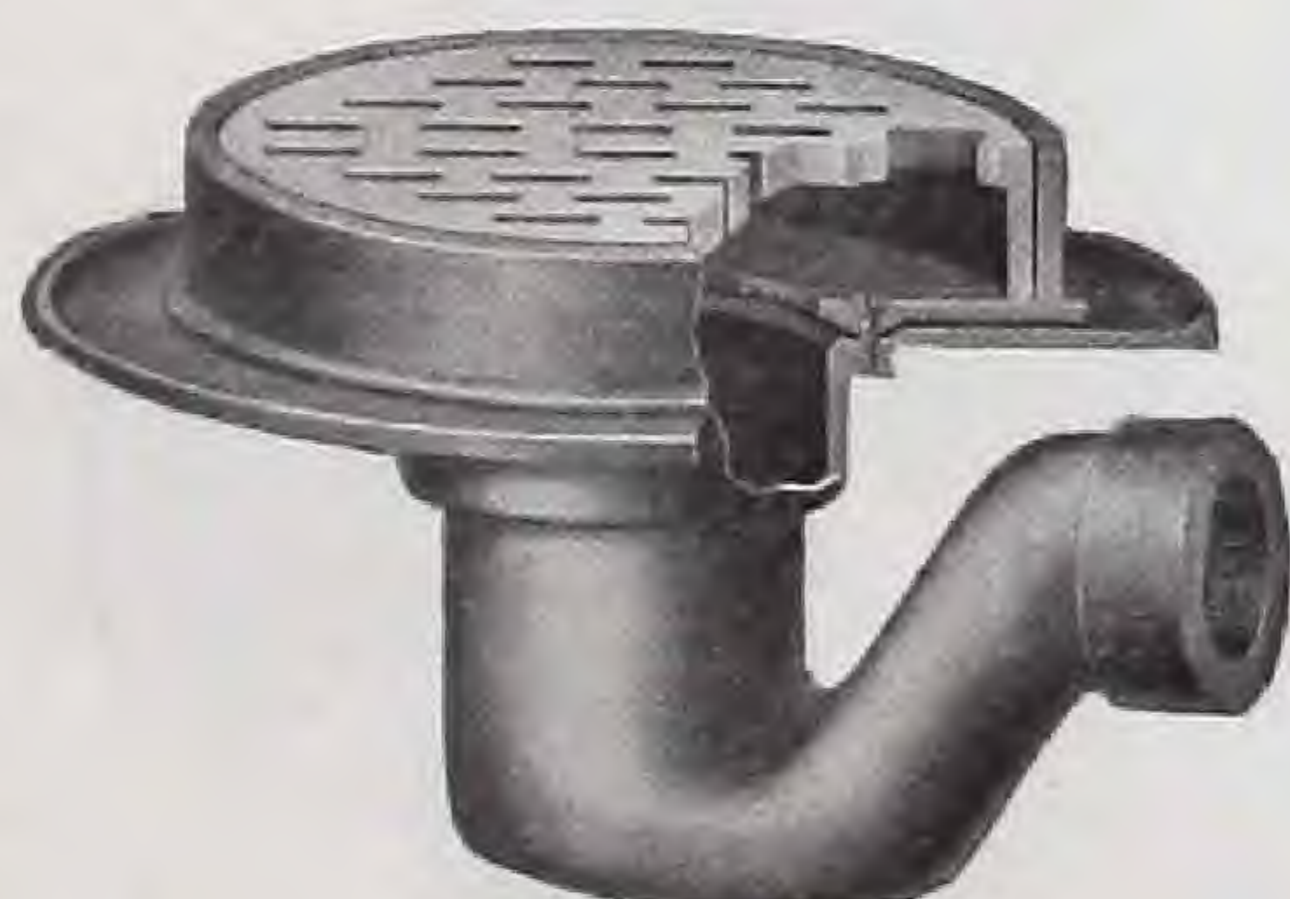

No. 126-131

Washroom Floor Drain and Trap

Outlet tapped 2 or 3 inch.
Diameter of iron strainer 9 inches.
Diameter of seepage flange 11 inches.
Depth of trap 9 inches.

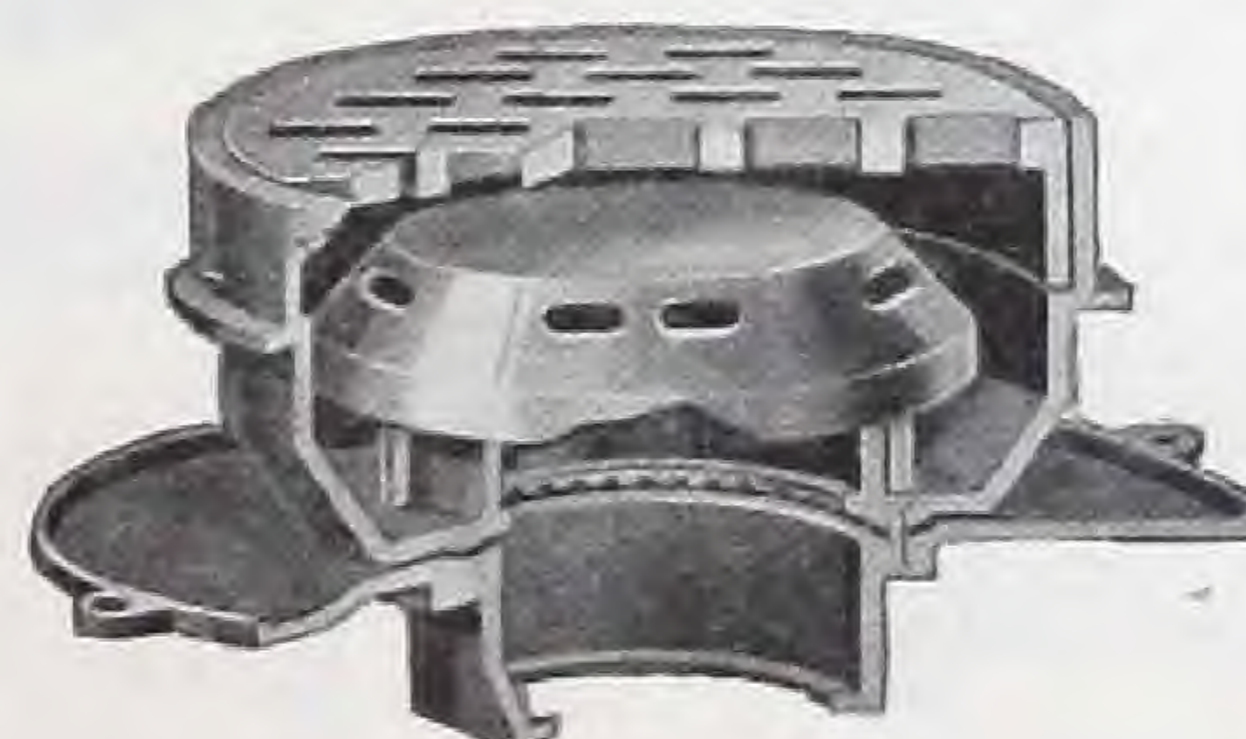

No. 163

Factory Floor Drain Head

Guard over inlet.
Hub outlet 3 or 4 inch.
Diameter of strainer 12 inches.
Diameter of seepage flange 15 inches.
Depth of head 6 1/2 inches.
Also furnished with brass top and hinged strainer.

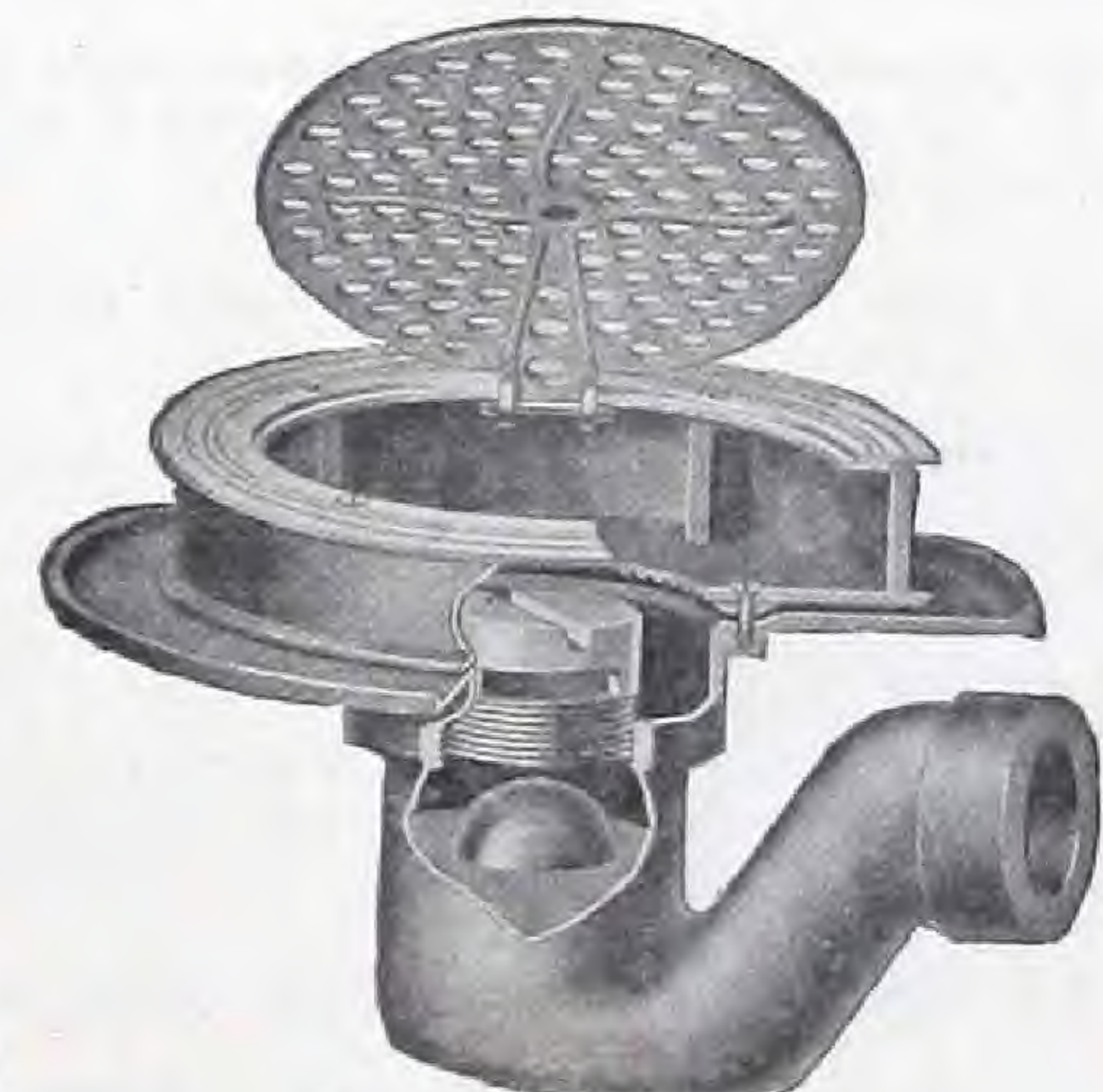

No. 126-132 B. W.

Back Water Shower Drain and Trap

Outlet tapped 2 inch.
Nine-inch brass top with hinged strainer
Copper float 2 1/4 inches.
Diameter of seepage flange 11 inches.
Depth of trap 9 inches.

Boosey's Seepage Urinal Drains

(Patented)

Urinal Drains may be used with or without lead pans

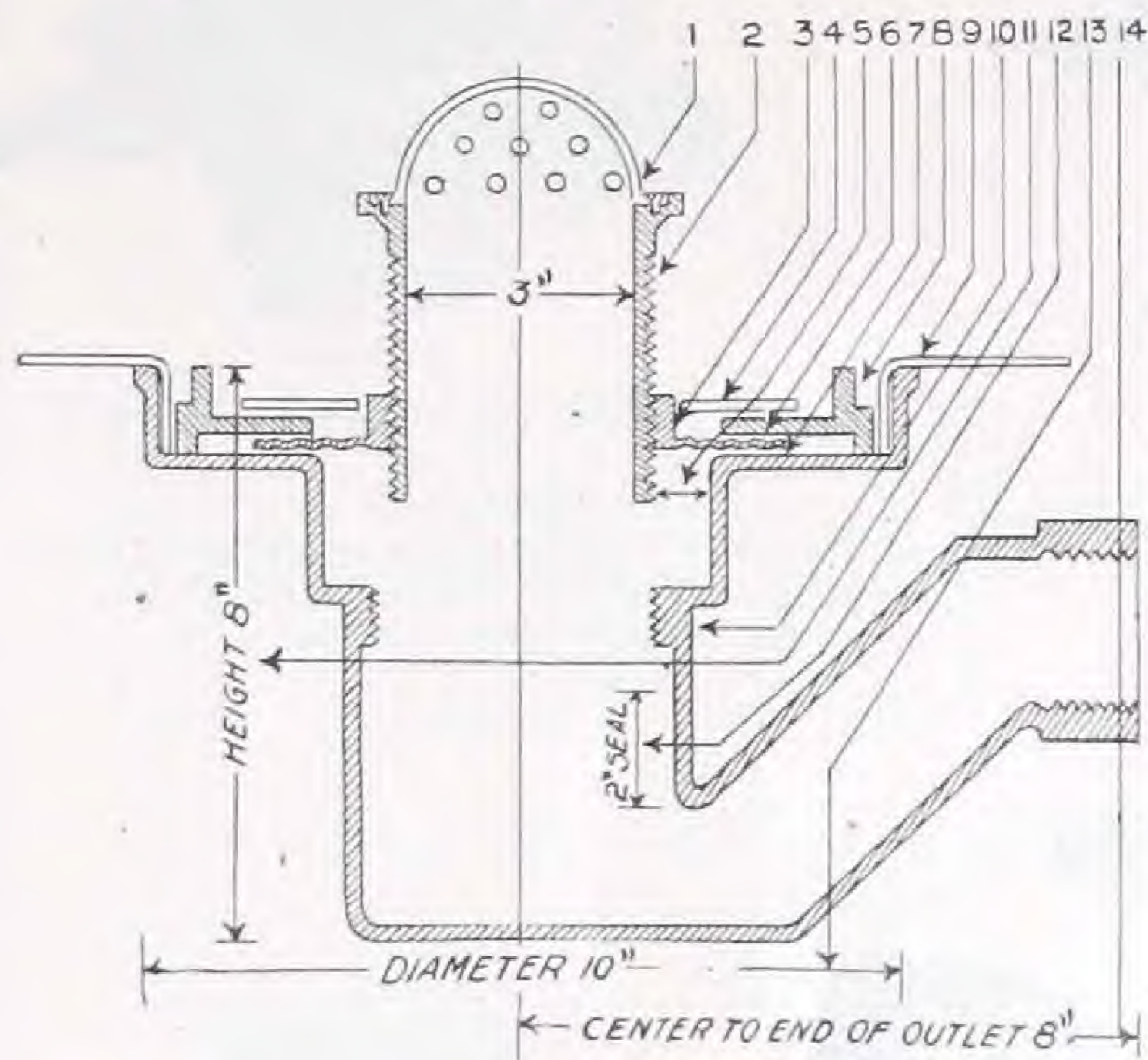

No. 126-135

Seepage Shower and Urinal Trap

(1) Brass nickelplated beehive or flat strainer secured to tail piece with removable brass screws.

(2) Extra long brass tail piece, length 4½ inches, threaded 3-inch standard iron pipe size.

(3) Seepage plate. Red brass, diameter 6 inches with grooves top and bottom of plate allowing seepage to pass over and under plate and drain back into waste.

(4) Loose pulp guard placed over seepage holes to prevent their being filled with cement.

(5) Shows space into which the urinal tail piece may be adjusted either vertically or horizontally.

(6) Adjustment plate which securely holds the brass seepage plate in place, but allows the plate to be moved in any horizontal direction for centering the waste connection.

(7) Space under the adjustment plate permitting shifting of seepage plate for centering.

(8) Recess formed by adjustment plate for securing the lead pan and adjustment plate to trap with calked joint.

(9) Lead pan which is permanently secured to urinal trap with a calked joint.

(10) Threads in the upper portion of trap for securing an iron plug for rough test. The plug also prevents dirt entering trap and waste line during building construction.

(11) Height of 2-inch trap, 8 inches. Height of 3-inch trap, 11½ inches.

(12) Depth of seal in 2-inch trap, 2 inches. Depth of seal in 3-inch trap, 3 inches.

(13) Outside diameter of flange, 10 inches.

(14) Center to end of outlet, 8 inches.

Either before or after the urinal is set, the waste inlet to trap can be adjusted to any center within a radius of 1½ inches by sliding the brass seepage plate to the required position.

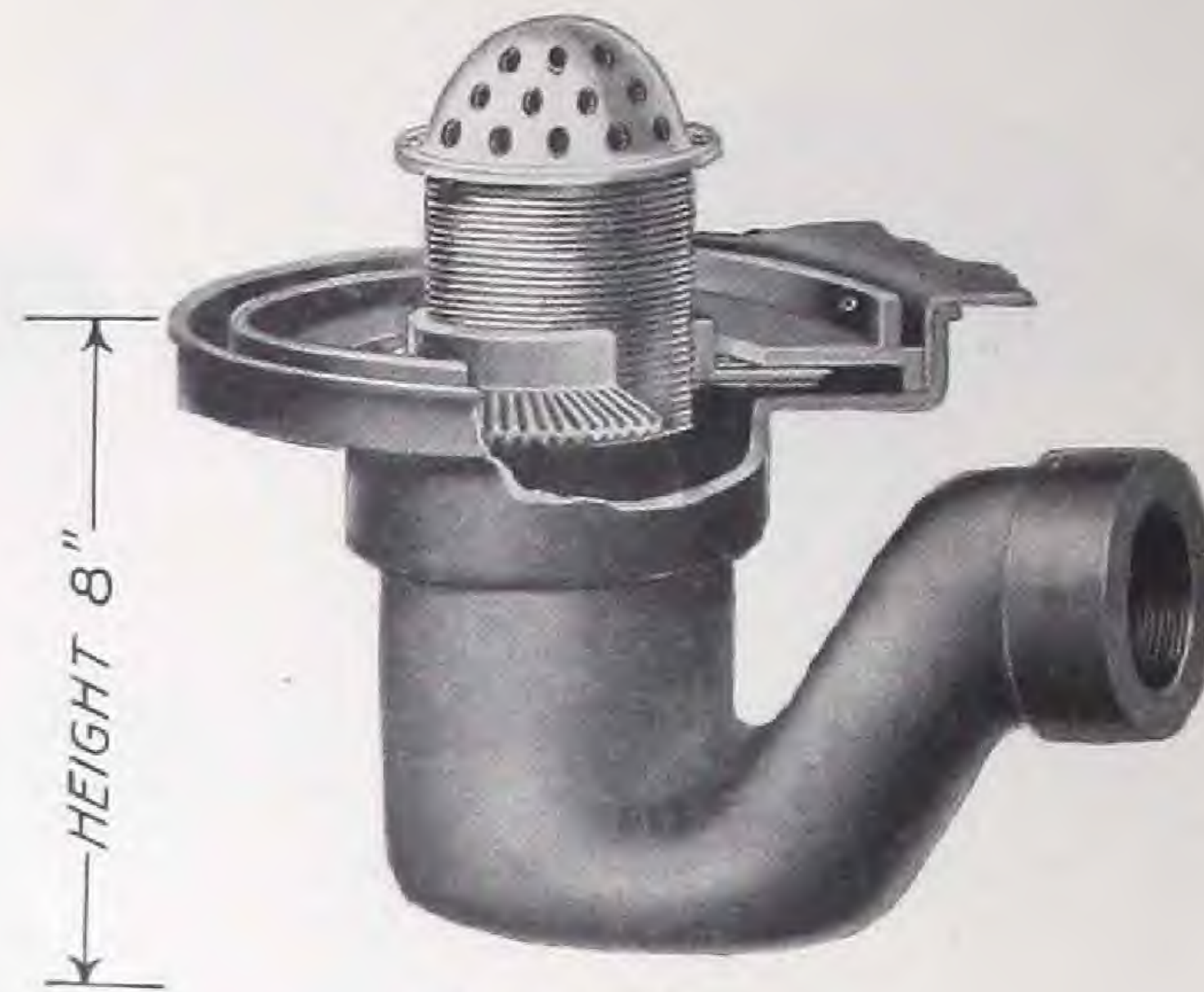

No. 126-135
Urinal Trap—Outlet, 2 Inches

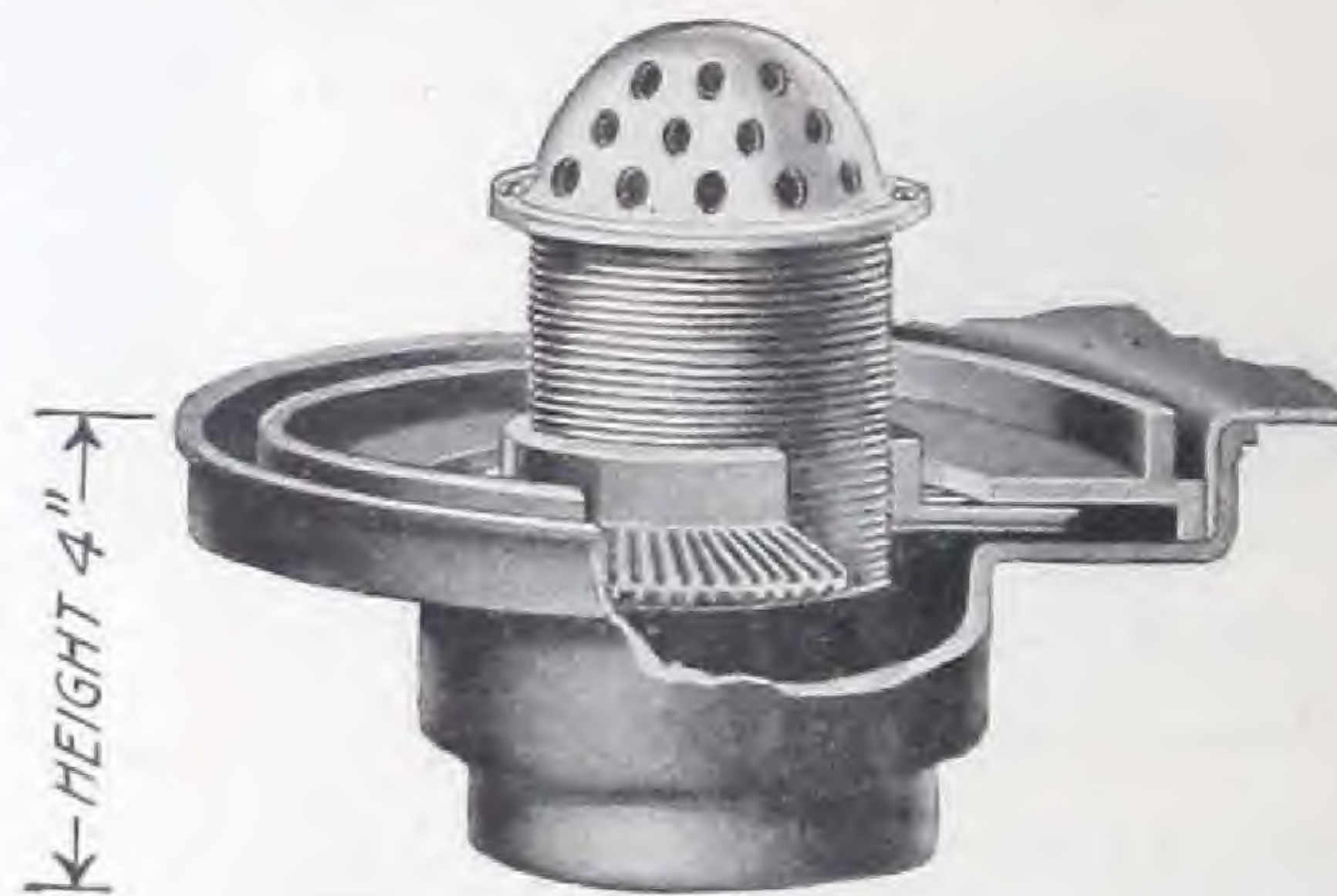

No. 135
Urinal Drain Head—Outlet 2 or 3 Inches

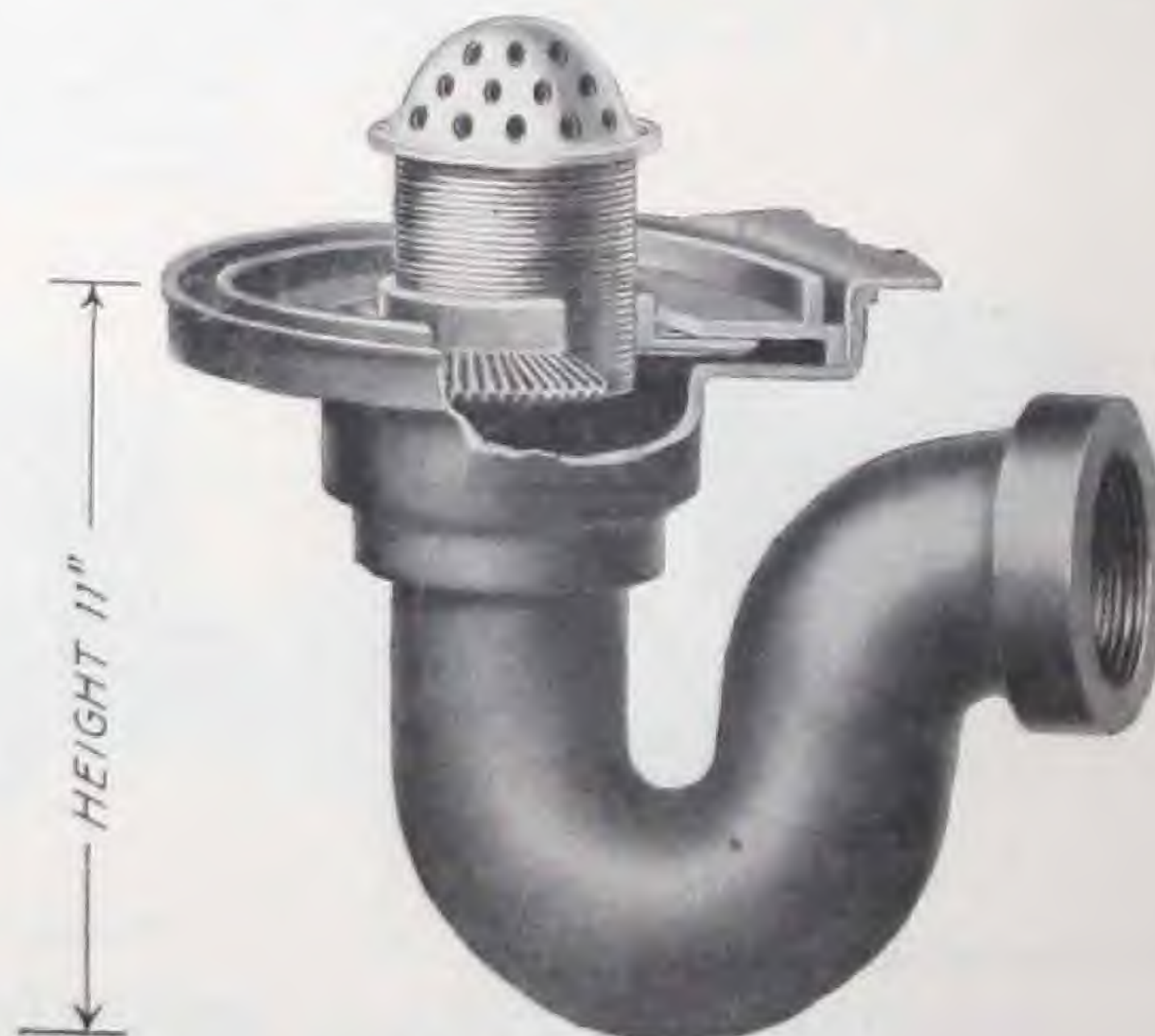

No. 70-135
Urinal Trap—Outlet, 3 Inches. Also furnished with Flat Strainer

Manufacturers of Drainage Specialties

APPROVED DRAIN COVERS

For factories, garages and driveways. Carrying weights from 500 pounds to 20 tons.
In stock for immediate shipment.

EXTRA LARGE CAST IRON COVERS AND RINGS



No. 615-B



No. 615

Series No. 615 is made with either loose or sealed covers. The outer ring is beveled to anchor firmly in the concrete. Outside diameter of ring is 46 inches, diameter of cover 36 inches, depth of ring 2 inches. This cover has been especially constructed for factory sumps, pump wells and meter pits. A depth of only two inches allows it to be set in almost any conceivable place.



No. 150

Floor Drains

Cast iron shallow drain head.
Diameter 14 inches.
Depth 4 inches.
Waste outlet either 3 or 4 inches.
Carrying weight approximately 1 ton.



No. 163

Factory Seepage Floor Drain Head

Guard over inlet.
Hub outlet 3 or 4 inches.
Diameter of strainer 12 inches.
Diameter of seepage flange 15 inches.
Depth of head 6½ inches.
Also furnished with brass top and hinged strainer.



No. 180

Floor Drain

Cast iron with double strainer and bell trap.
Diameter of top 12x12 inches.
Depth 10 inches.
Carrying weight approximately 2 tons.

GREENWOOD MFG. CO.

5140 HAMILTON
AVENUE

Detroit, Mich.

**ROAD, GARAGE, AREA WAY AND YARD
DRAIN COVERS**



No. 335-A



No. 335-B



No. 335-E

The No. 335 series of covers is X II and will support an approximate load of 20 tons. The diameter of ring at base is 28 inches, diameter of top 22 inches, depth of ring 7 1/4 inches. Standard road size.



No. 336-A



No. 336-H



No. 336-E

The No. 336 series of covers is medium weight and will support an approximate load of 18 tons. The diameter of ring base is 27 inches, diameter of top 22 inches, depth of ring 4 inches. The No. 336-E is made in three weights. Carrying capacity, 1, 5 and 10 tons. The No. 336-H for lawns, yard and ditch drains has a raised strainer guard.

An important feature of all the above covers is the concrete outer ring. It adds to the moulding cost, but it is the only satisfactory method of anchoring the ring in the concrete so that it is impossible for it to break loose or damage the sewer connections below.

GREENWOOD MFG. CO.

5140 HAMILTON
AVENUE

Detroit, Mich.

Approved Construction for Garage Sump
City of Detroit

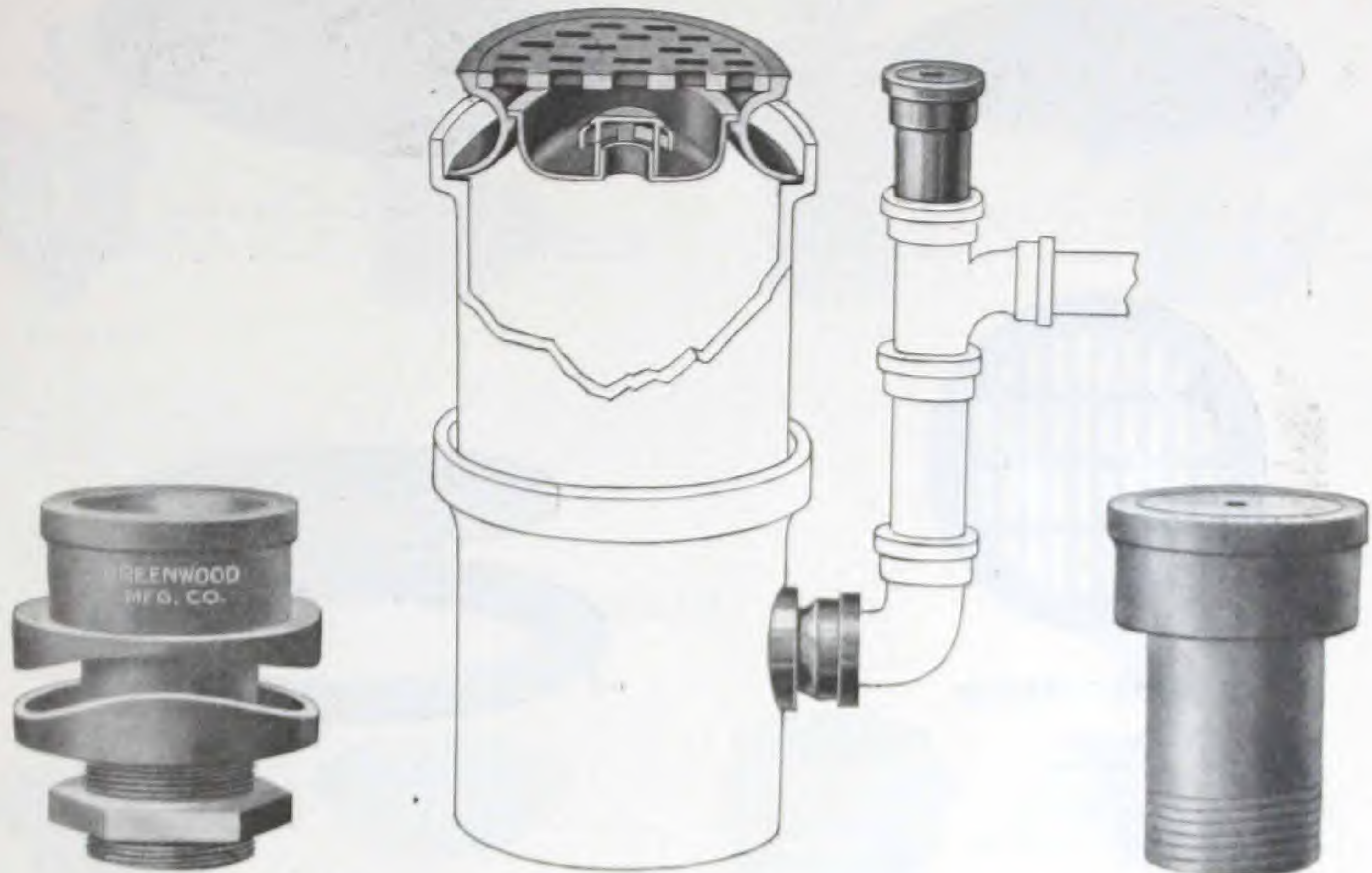

No. 390

Cast iron connection for securing 4-inch soil pipe to crock sump. The two flanges are filled with cement and are then drawn to place with a lock nut. This makes a permanently tight joint to which the soil pipe is caulked.

No. 807

Cast iron road cleanout with brass plug. Carrying load estimated at 20 tons. The brass cleanout in base of hub is protected with heavy iron cover set into hub. Made in two sizes, 3 and 4-inch. Length, 8 inches.



No. 160

Cast iron auxiliary drain to sump. Diameter 12 inches, depth 6 inches. Waste outlet hub slips either 3 or 4 inch soil pipe. Carrying load approximately 20 tons.



No. 335-F

This sump cover is made with a catch basin for it is more convenient and requires much less time to remove mud and sand from the catch basin in cover than to bail out the sump and then dig the dirt out of the bottom.



No. 182

Wash rack drain, cast iron, easy to clean or inspect. The mud trap prevents dirt or sand from entering waste line or sump. Carrying weight approximately 1 ton. Size 12x14 inches. Hub outlet on side slips either 3 or 4-inch soil pipe. Outlet center 8 inches from top.

The Greenwood Manufacturing Company's garage sump construction, using 24-inch crock for sump, is approved by public works, building and sanitary departments.

GREENWOOD MFG. CO.

5140 HAMILTON
AVENUE

Detroit, Mich.

MISCELLANEOUS COVERS



No. 240

Cast Iron Covers for Crock Hubs

The legs elevate cover flush with top of hub. This series includes covers to fit crocks from 4 to 24 inches.



No. 200

Cast Iron Cover and Frame

This series includes covers from 10 to 25 inches. Designed for covering valves, cleanout plugs, small meters, etc.



No. 375

Area Drain

Cast iron ring and grating. Diameter of ring 24 inches. Diameter of cover 21 inches. Carrying weight approximately 1/4 ton.



No. 300

Light Drain Covers

Carrying weights from 1/2 to 3 tons. Diameters of rings 17 to 34 inches. Diameters of strainers 12 to 24 inches.



No. 604

Cleanout Frame and Cover

Ring diameter 21 to 24 inches. Cover diameter 16 to 20 inches.



No. 273

Meter Pit Cover and Frame

Cast iron. Made in two sizes. Size of cover 17x24, frame 23x28. Size of cover 24x24, frame 30x30.



No. 300

Shallow Factory Manhole Cover

Diameter of ring 27 inches. Diameter of cover 20 inches. Thickness of inside cover 1 inch.



No. 170

Cast Iron Drain Cover and Trap

Diameter 14 inches. Dept 6 1/2 inches. Waste outlet either 2 or 4 inches. Carrying weight approximately 1 ton.

GREENWOOD MFG. CO.

5140 HAMILTON
AVENUE

Detroit, Mich.

ADJUSTABLE SHOWER DRAINS

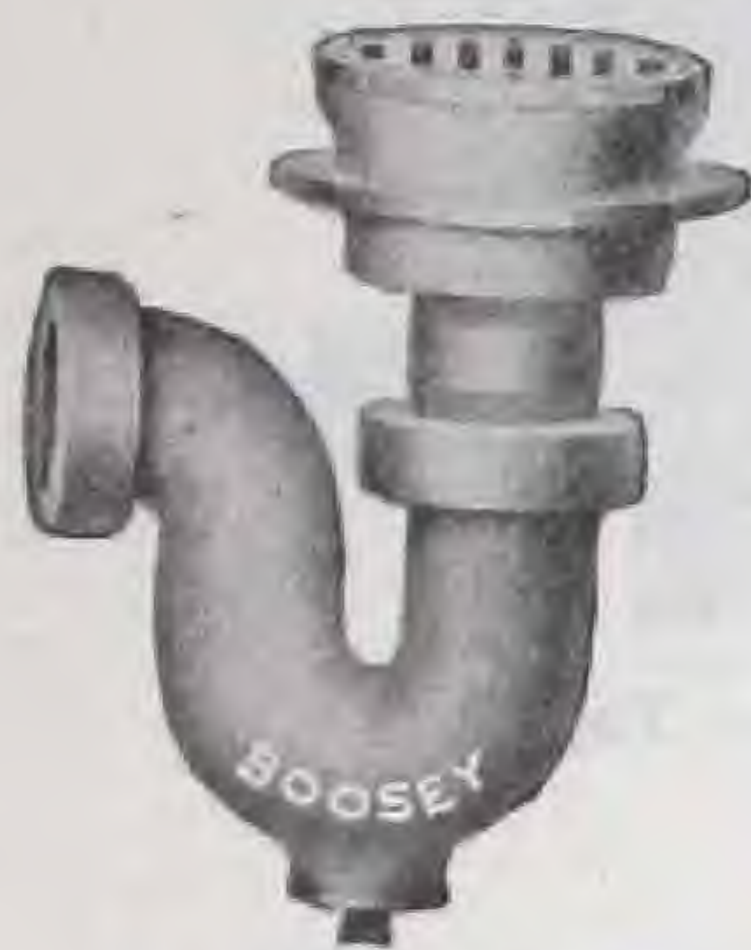

No. 70-91-2



No. 120



No. 122



No. 121

For ordinary use these traps are O. K. The lead pan is connected to the trap body with a calked joint. Some mechanical skill is necessary in making this joint, but when securely calked it is absolutely water tight. Any moisture that soaks through the granolithic or tile floor down to the lead pan, naturally, must be taken care of by evaporation, as these traps are constructed without seepage openings. Trap bodies 4x8, tapped 1½ or 2 inches.

DRAIN HEADS



No. 95
Brass N. P. or polished Benedict nickel.
Diameter of top 5½ inches.
Length of thread 1½ inches.
Made with 2-inch standard iron pipe thread.



No. 94
Brass N. P. or polished Benedict nickel.
This strainer is made in two lengths, 2 and 4 inches, and with either a flat or beehive strainer.
Diameter of top 5½ inches.
Made with 3-inch standard iron pipe thread.



No. 124
Brass N. P. strainer and ring.
Body cast iron.
Tapped 3-inch standard iron pipe, female.



No. 91
Brass N. P. strainer and ring.
Body cast iron.
Tapped 2-inch standard iron pipe, female.



No. 92
Floor Drain
Iron body tapped 3 inch, female.
Depth 4 inches. Fitted with 9-inch finished brass top, with hinged strainer secured to iron body with brass screws.
Also furnished in polished Benedict nickel.



No. 96
Factory Floor Drain
Iron body tapped 3 inch, female.
Diameter 8 inches, depth 4 inches.
Fitted with iron or brass strainer ½-inch thick, hinged to body with brass bolt.



No. 863-B
Plenum Chamber Drain
Iron body, depth 4½ inches.
Diameter 9 inches, with iron strainer or all-brass top with hinged strainer.
Outlet fitted inside with 3-inch brass plug with oblong raised head.

GREENWOOD MFG. CO.

5140 HAMILTON
AVENUE

Detroit, Mich.

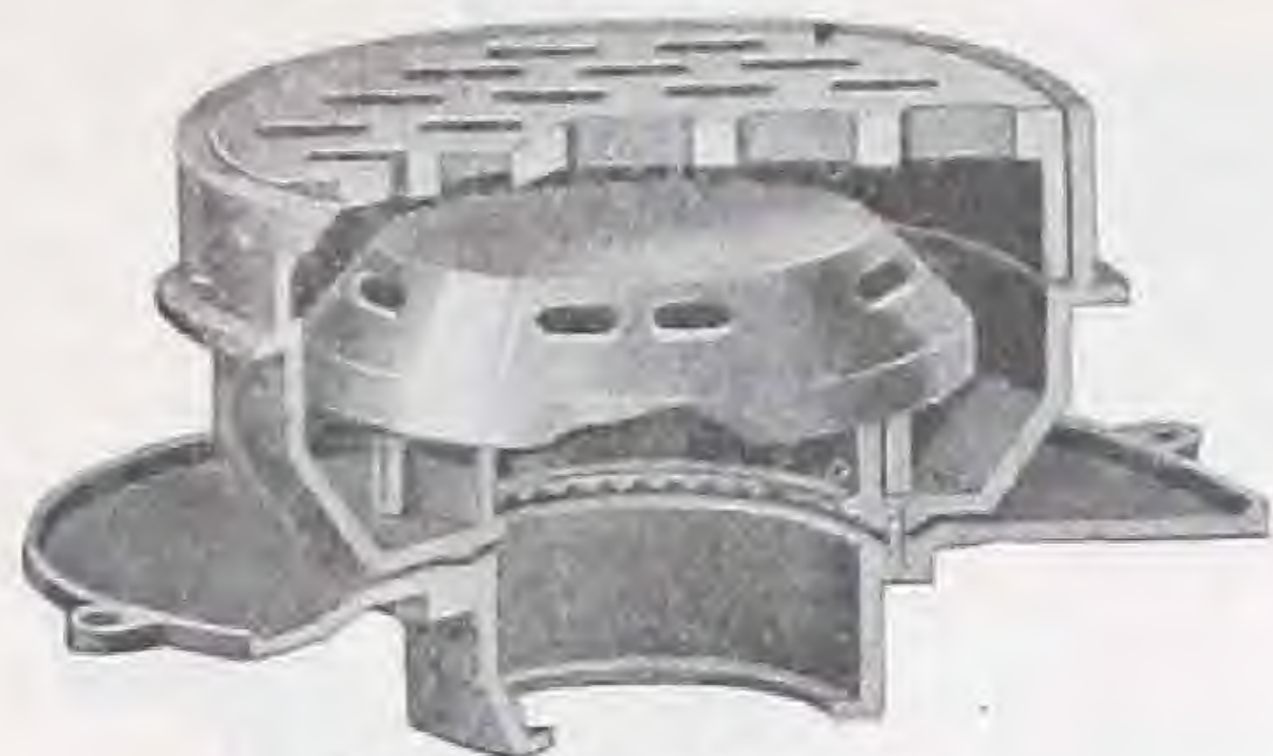

No. 163—Iron Top

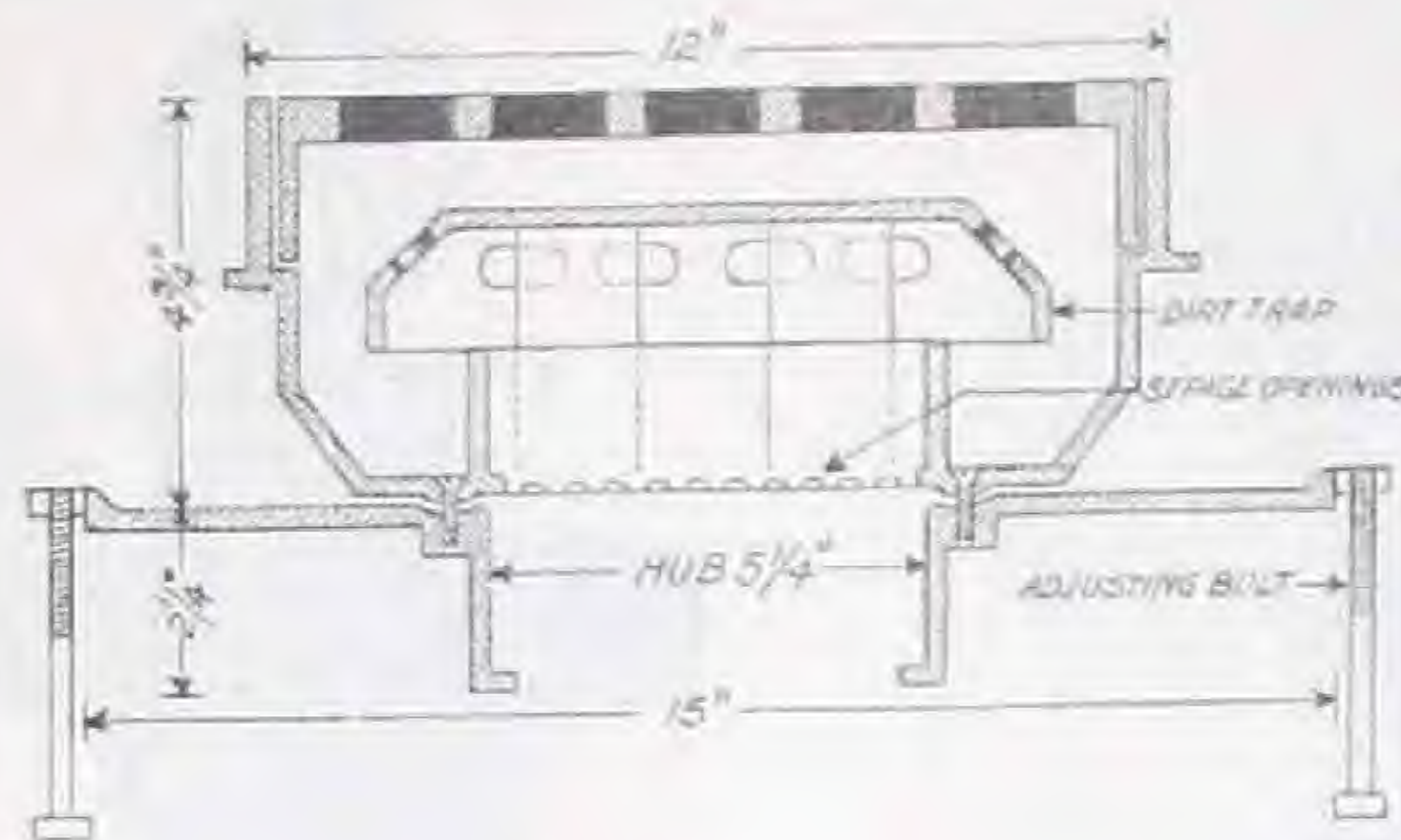

No. 163

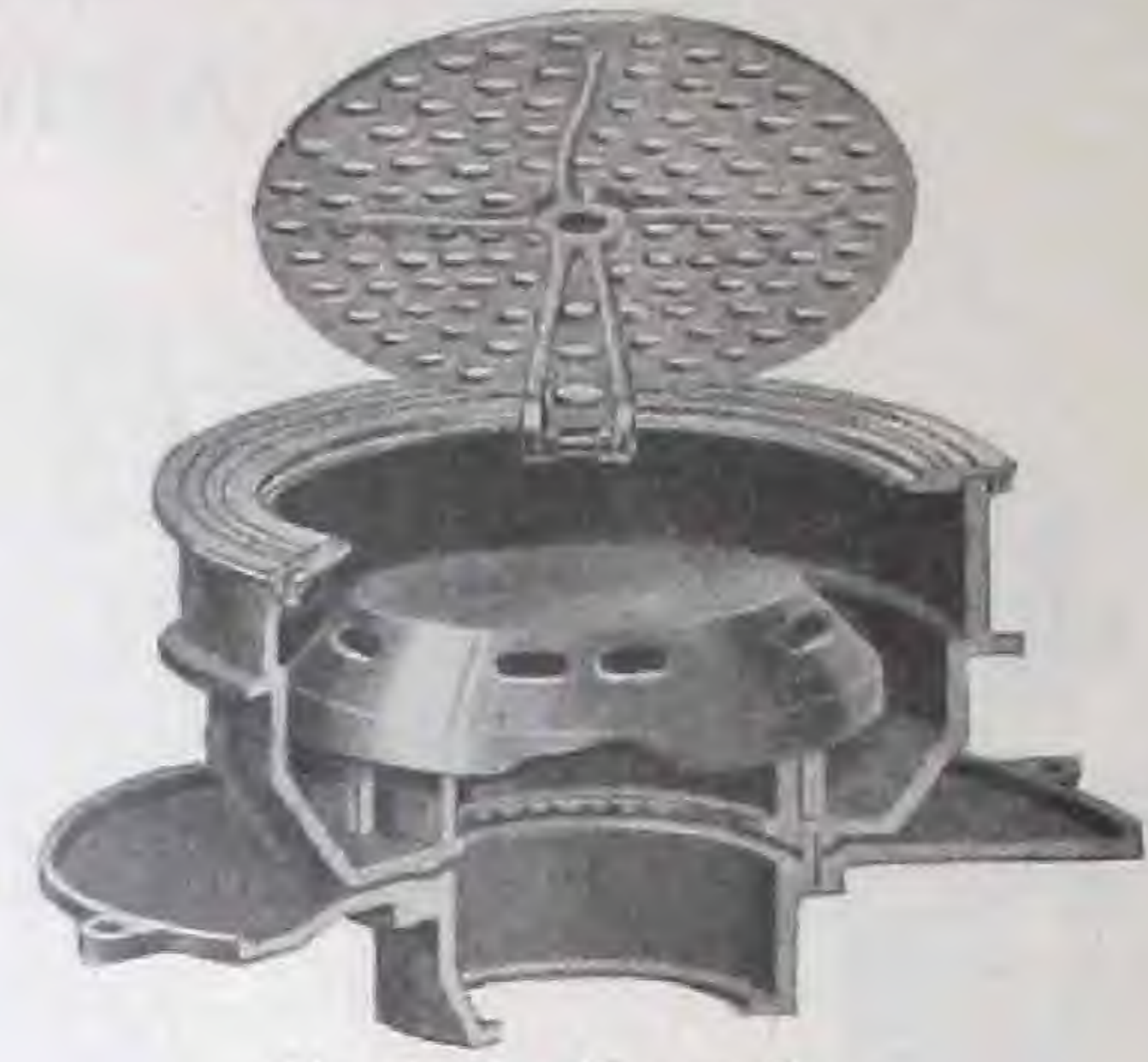

No. 163—Brass Top

SEEPAGE FACTORY FLOOR DRAIN

Cast iron with non-tilting slip cover 1 3/4 inches deep. The outer edge of seepage flange is tapped for adjustment bolts so that it can be set at the exact floor line before pouring the concrete.
The drain is also provided with a dirt trap which prevents metal cuttings, sticks and other foreign substances entering waste line. Hub outlet made to slip either wrought iron pipe or tapped for screwed thread. Waste outlet, 3 or 4 inches.

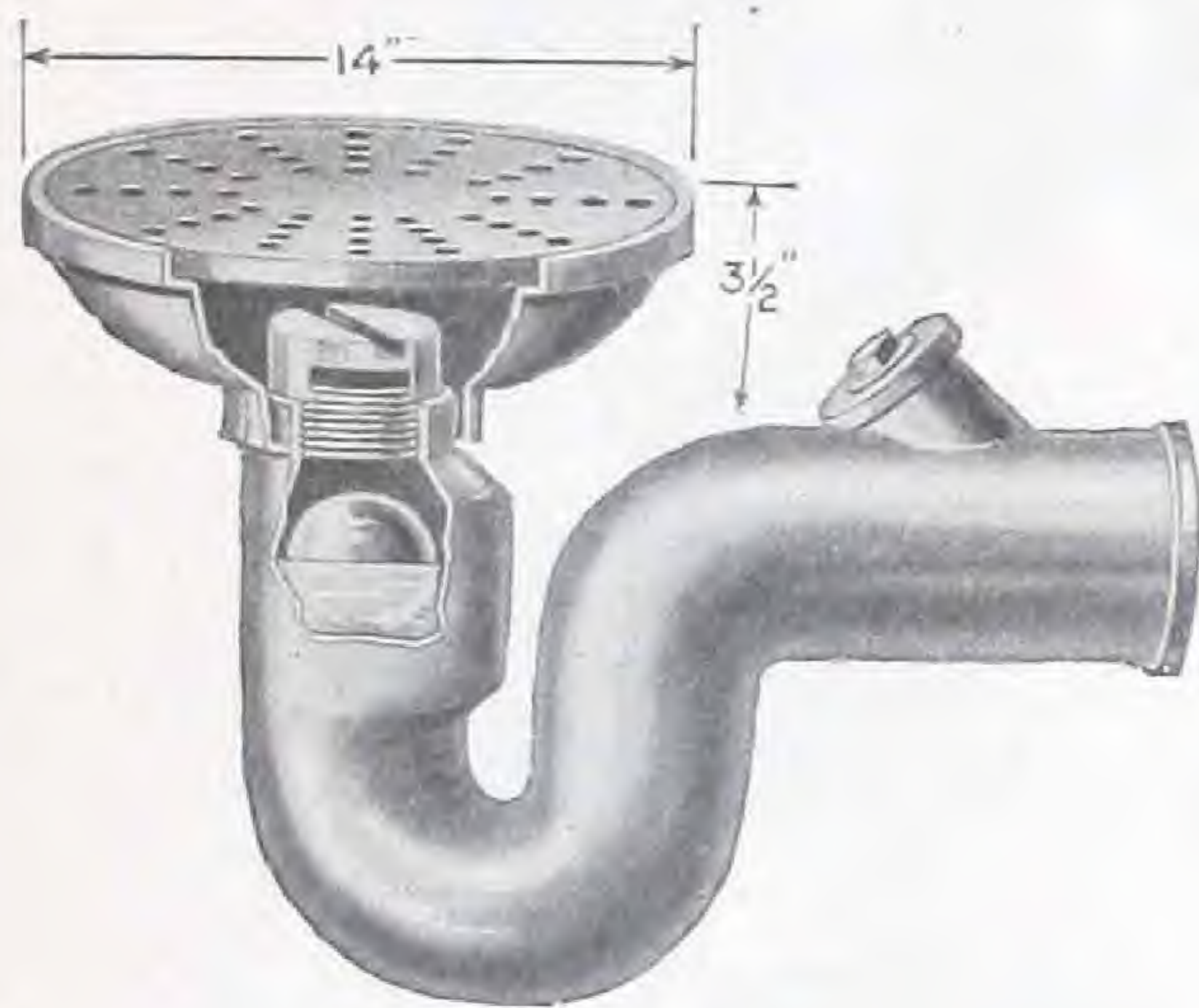

No. 112

Floor drain and float valve with closed top which prevents sticks, etc., being poked into trap and ruining the copper float.
Made in three sizes, 2, 3 and 4-inch.

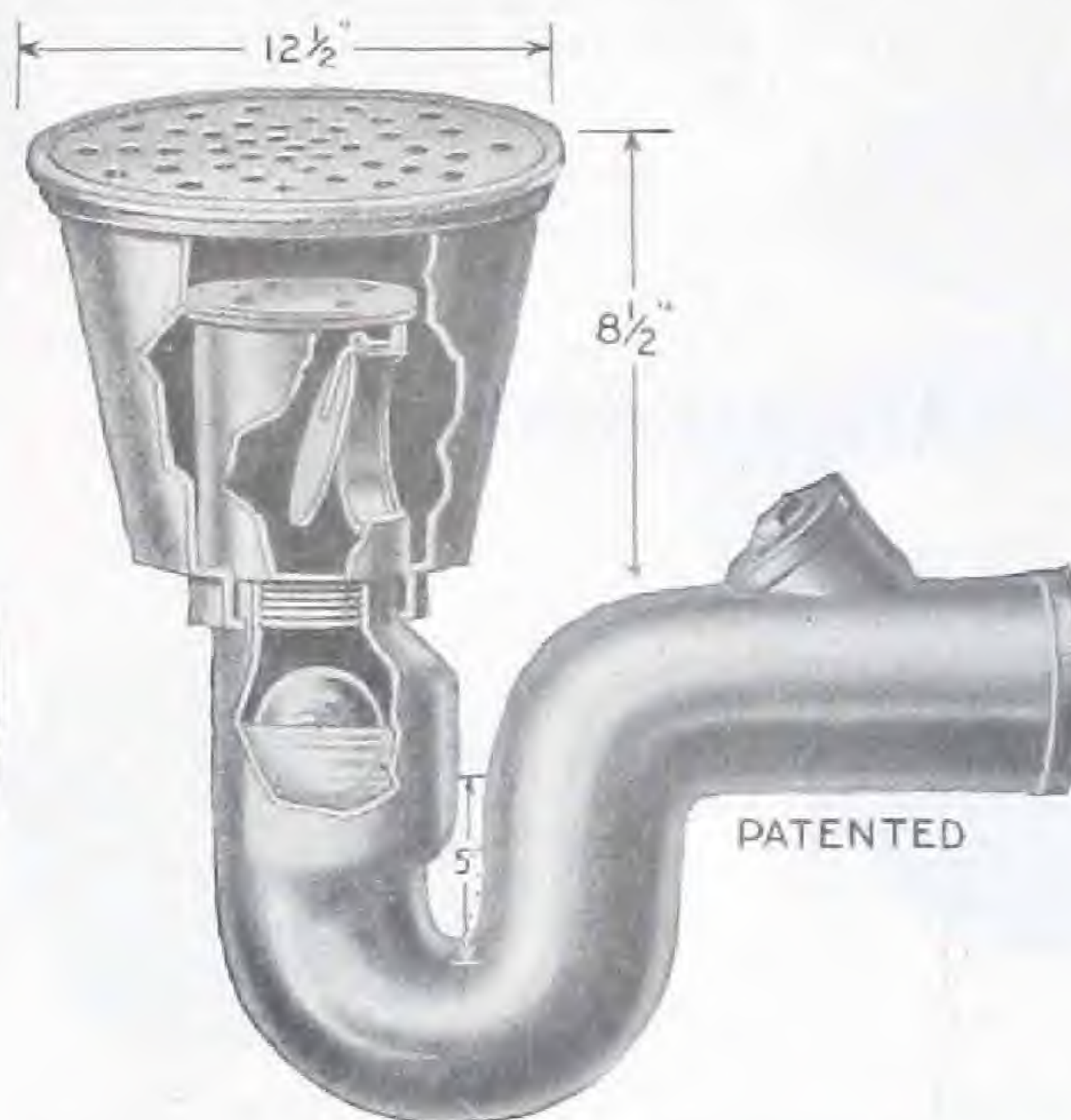

No. 111

The No. 111 double valve floor drain is designed specially for deep basements. It is real insurance against damage from back water.
Made in 4-inch.

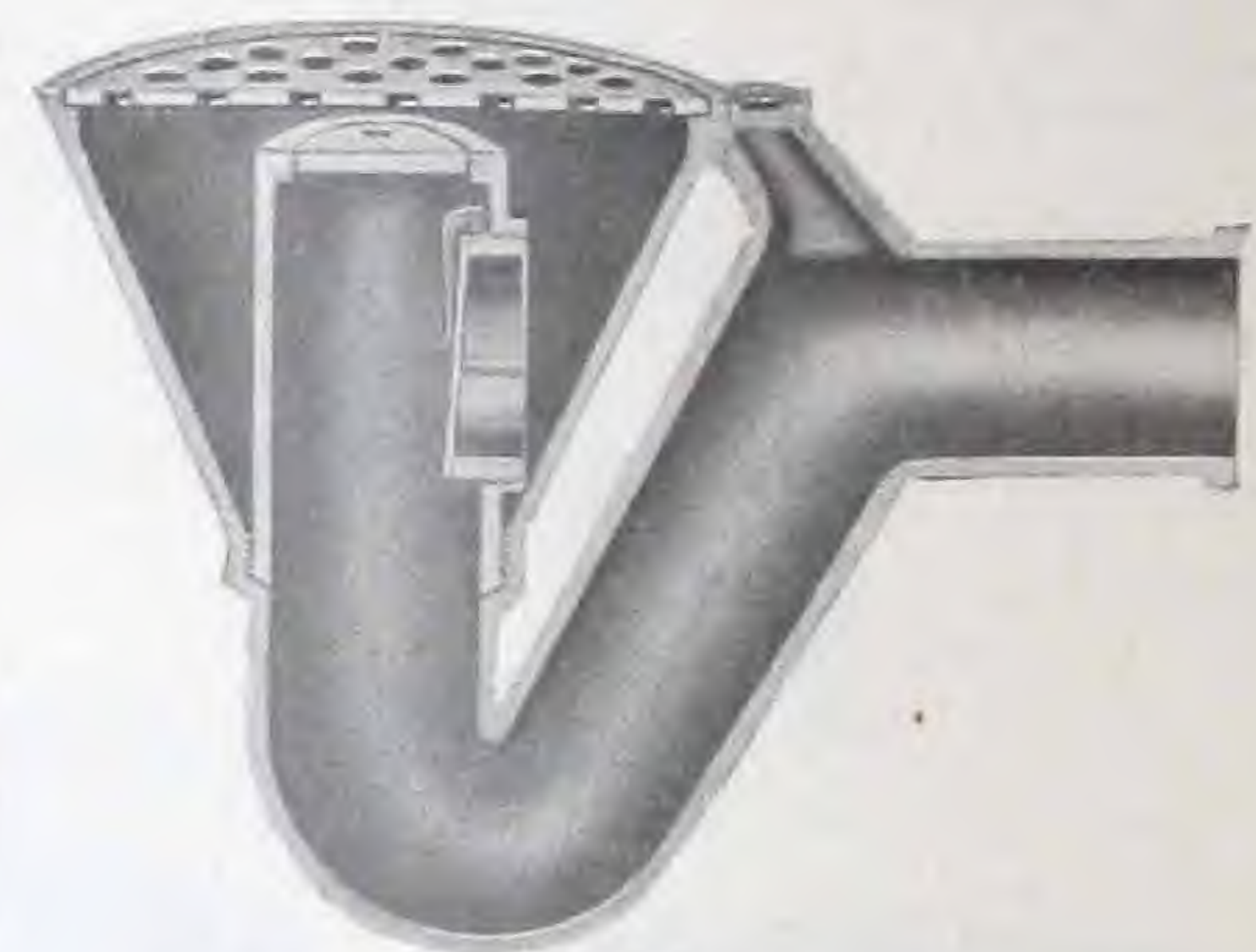

No. 108

No. 108 with single, or No. 111 with double valve. The swing check valve is placed above the water that forms trap seal and therefore is always accessible for cleaning or inspection.

These back water drains are especially suitable for cooling and storage rooms in public institutions, hotels, stores and packing houses. Should the trap lose its seal from evaporation, the fact that the check valve is always set in a closed position would prevent the free flow of sewer air into the building, making these drains doubly sealed against damage to property.

No. 108 three sizes, 2, 3 and 4 inches.

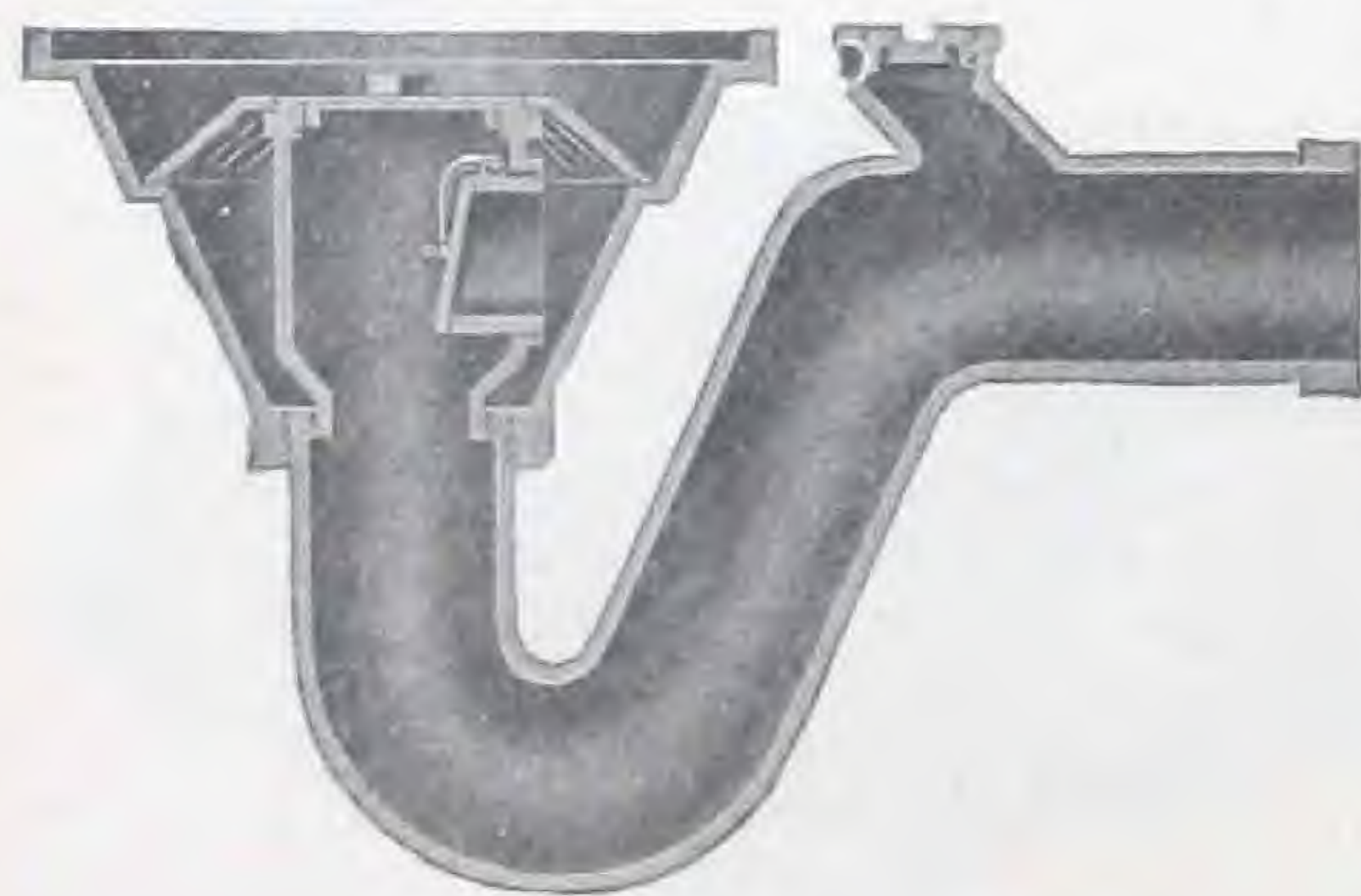

No. 108-B

Ice box drip sink and back pressure trap for basement ice boxes, soda fountains, etc.

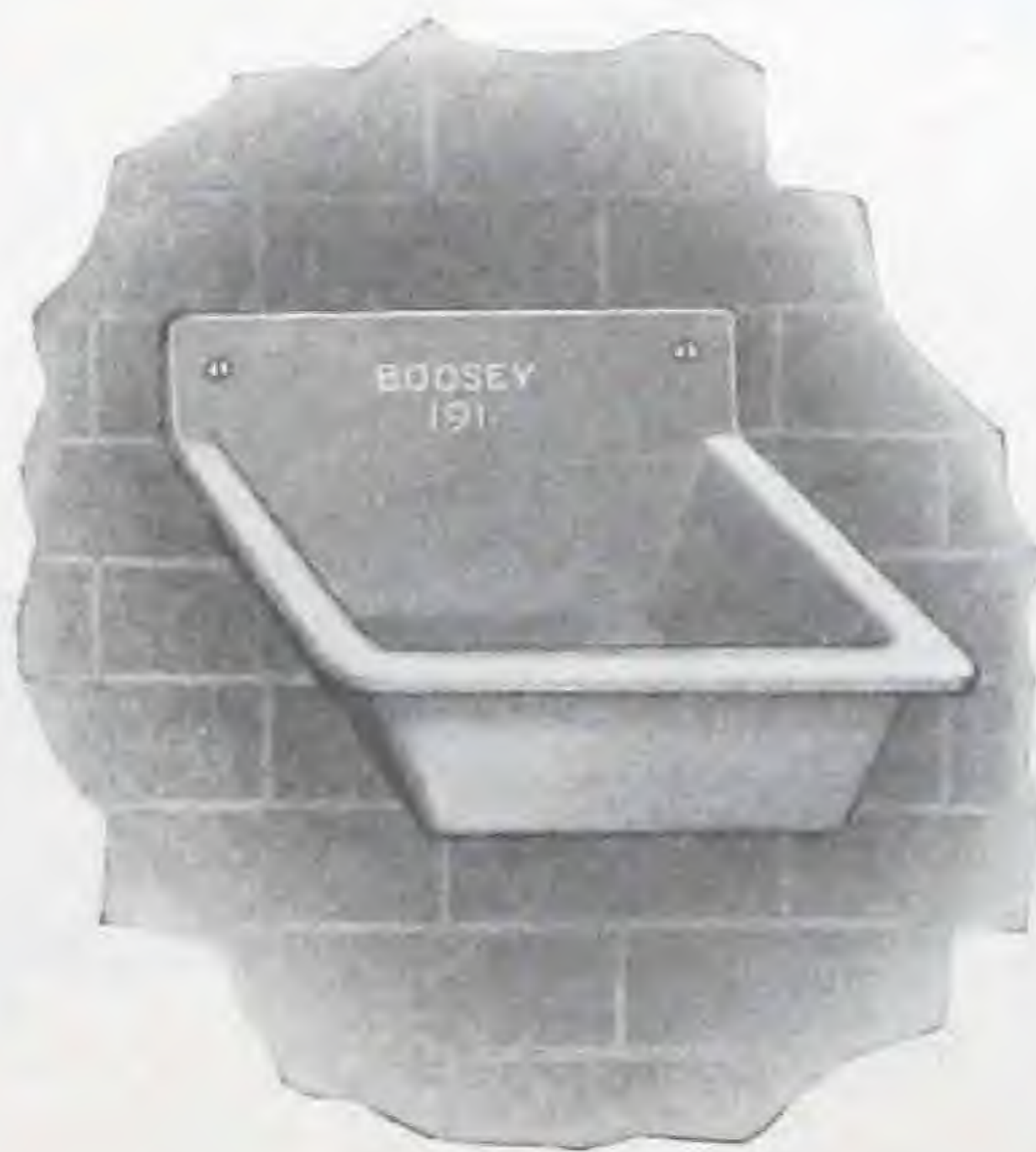

No. P-191

Ice box wall drip sink requires no brackets or framework. It is held securely to wall with two screws through the raised back. Outlet furnished with brass strainer and tailpiece.
Size 12x12, either painted or white porcelain enamel.

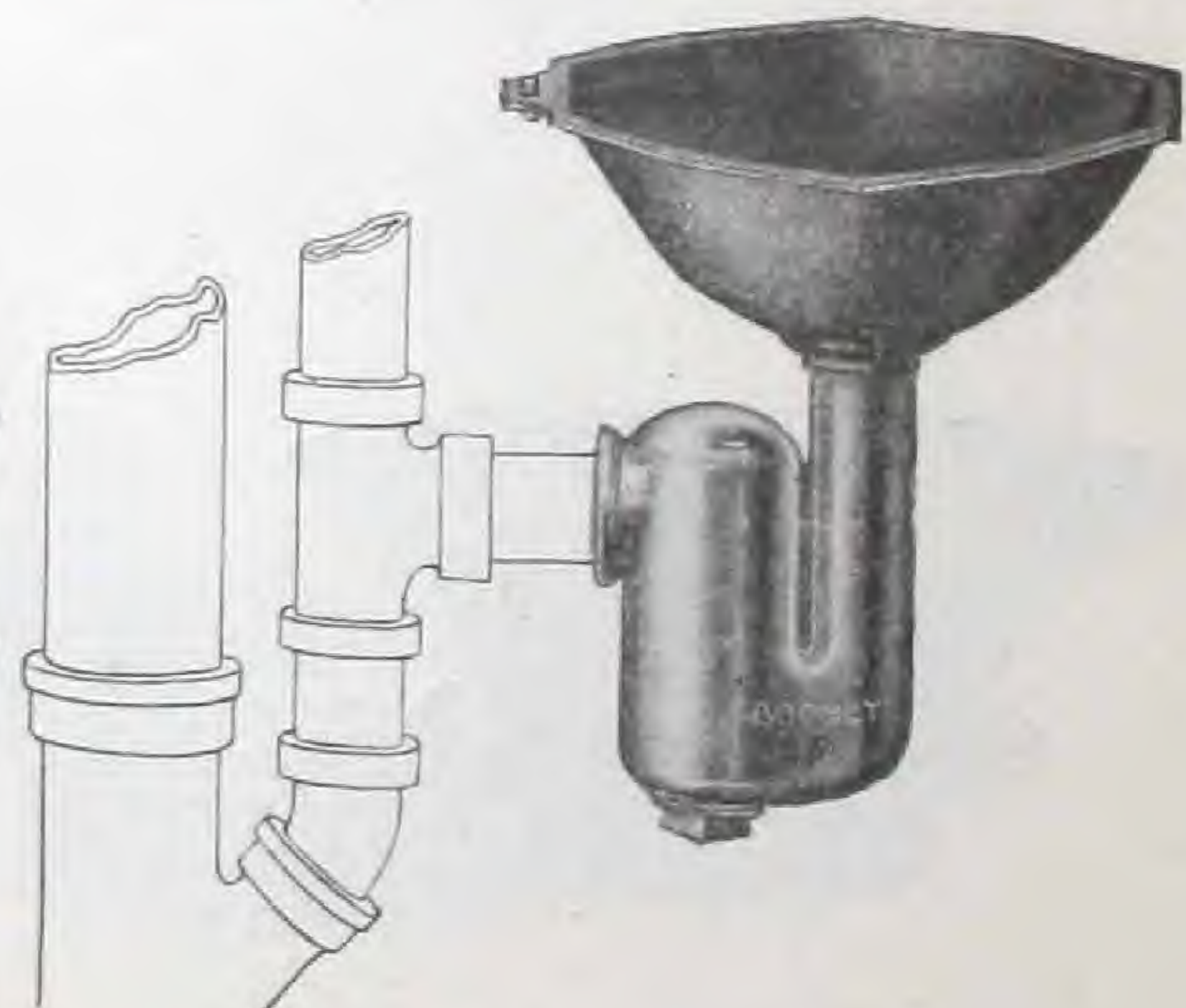

No. 192-66

Ice box drip sink and trap. Diameter of sink 12 inches. Waste outlet 1 1/2 inches. This combination gives a neat finished appearance to the basement plumbing.

GREENWOOD MFG. CO.

5140 HAMILTON
AVENUE

Detroit, Mich.

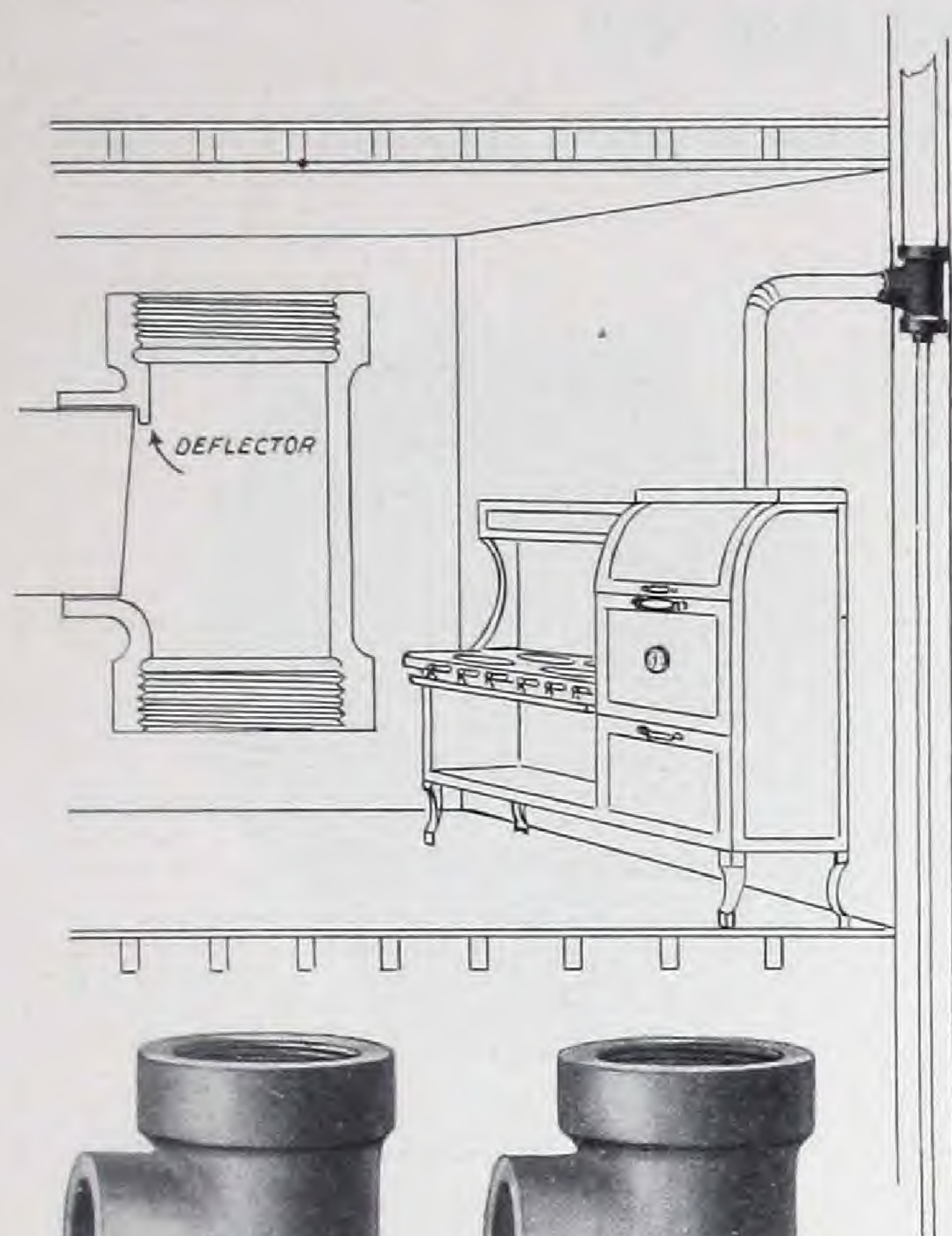

No. 670



No. 671

Pat. Pend.

**TEES
DRIP TEES
CROSSES**

GAS VENT PIPE FITTINGS

THE use of three inch wrought iron pipe for gas vent stacks is proving most satisfactory. It is economical and easily placed between the studding without furring.

Boosey's gas vent fittings are made to perfect the construction of wrought iron gas vent stacks, they prevent condensation or rain water dripping at the connection of stove flue to vent stack and staining the wall. The side opening is made on a slight taper, thereby securely holding the flue pipe in place. The stop, cast in the upper part of the side opening not only acts as a deflector of condensation but prevents the flue pipe extending too far into the vent stack, thereby shutting off the draft. The lower fitting in stack is provided with drip opening in base for draining all condensation or rain water to basement drain.

Where gas stoves are placed on opposite sides of wall requiring the use of a cross fitting the side openings are offset three inches, thereby preventing either stove choking the draft of the other.

Steam fittings should never be used for gas vent piping. Another source of trouble is using vent caps for hoods. They lower the velocity of stack draft, thereby lessening the efficiency of the oven and often causing it to smell.

[BLANK PAGE]



CCA

GREENWOOD MFG. CO.

5140 HAMILTON
AVENUE

Detroit, Mich.

ICE BOX DRIP BASINS AND TRAPS

To meet requirements of different codes and building construction

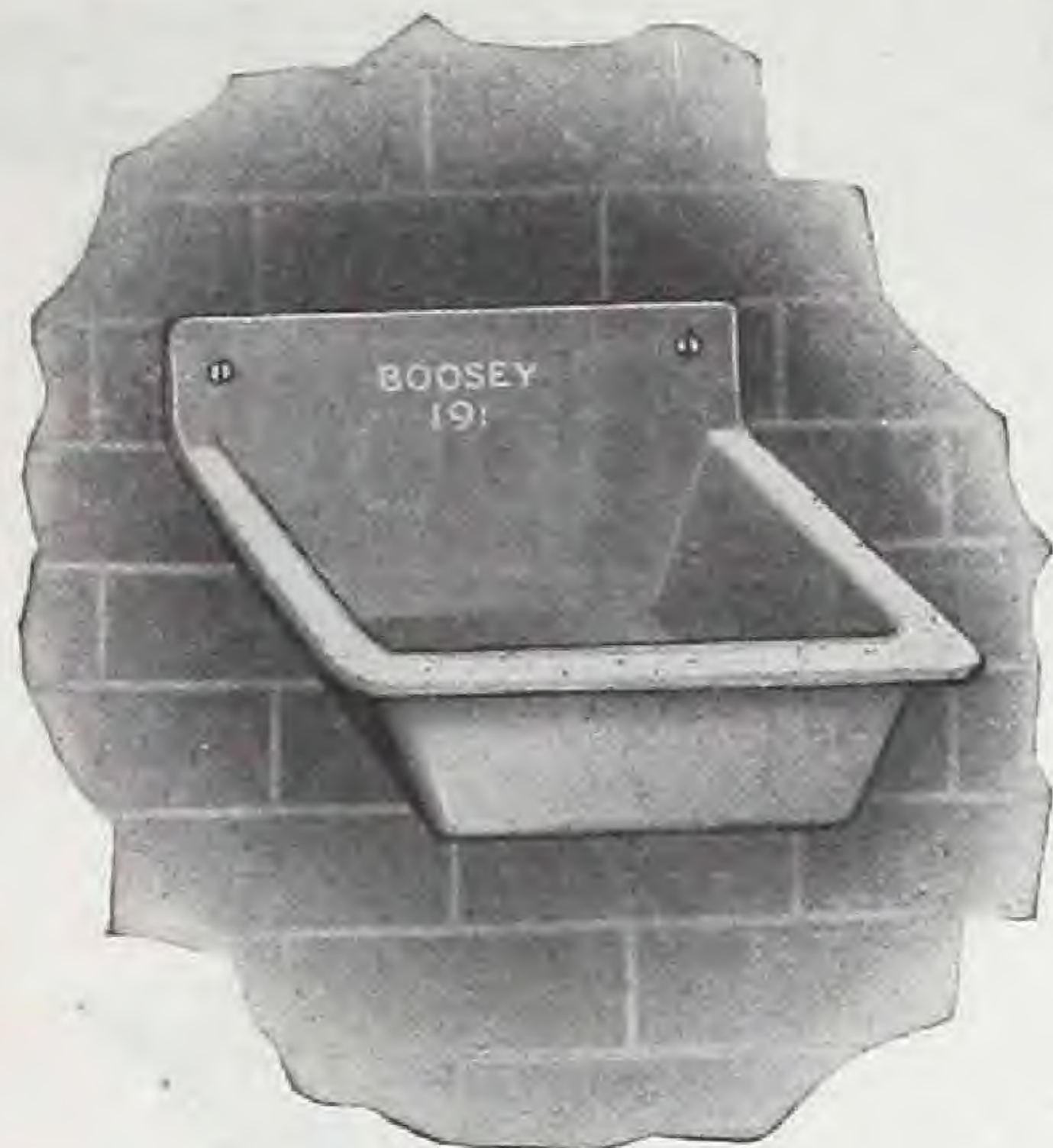

No. 191

Ice Box Drip Sink.
Diameter, 12x12.
White Porcelain Enameled.
Outlet, 1½ in. brass tail piece.
List \$12.60



No. 191-A

Ice Box Drip Sink.
Cast Wall Brackets.
Iron bar strainer.
Outlet tapped 1½ inches.
List \$2.80

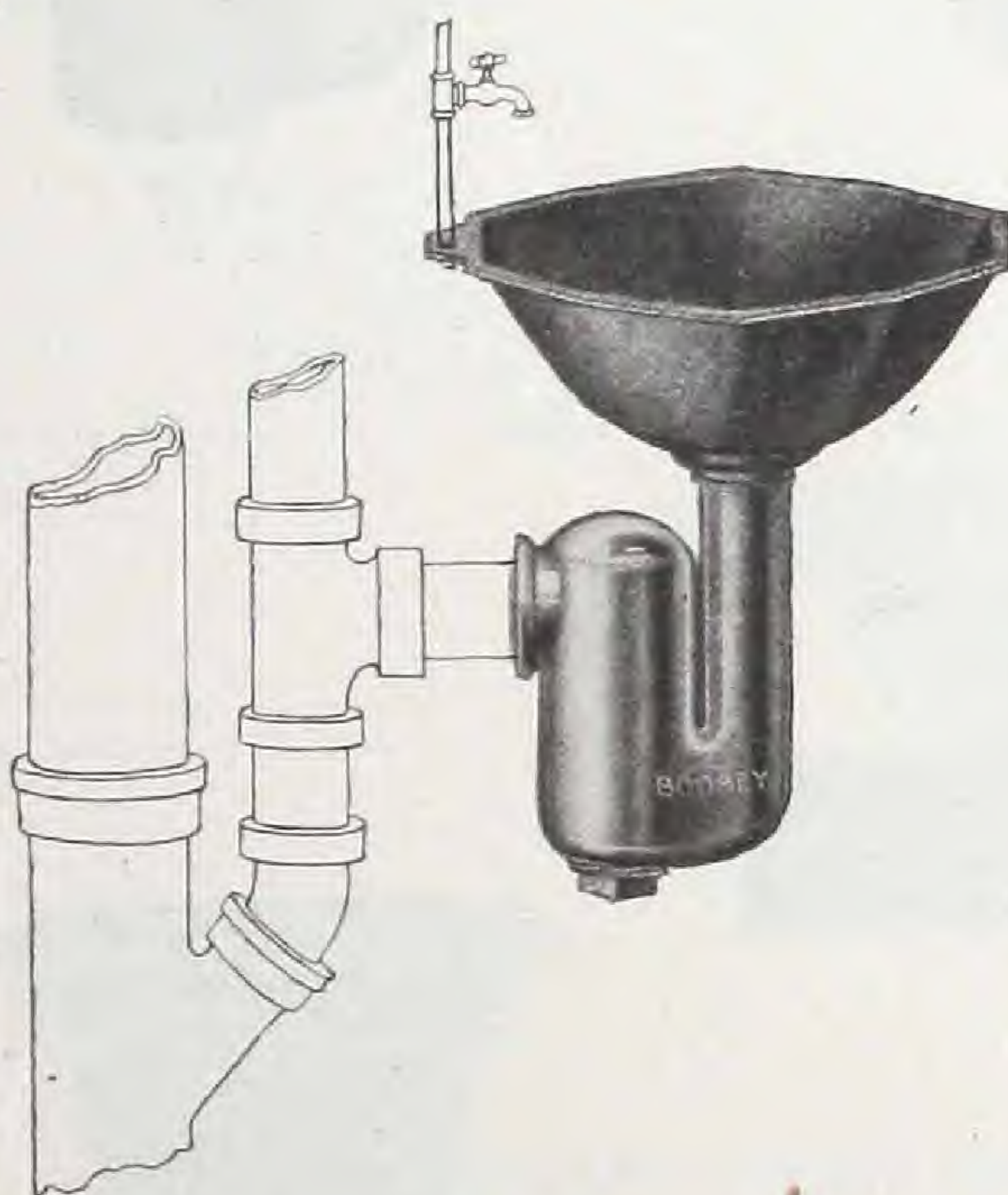

No. 192-66

Ice Box Drip Sink and Trap. Easily placed out of the way at any required height.
Adapted for fine residence work.
Diameter, 12 in.
Centrifugal Trap.
Outlet tapped 1½ inches.
List \$7.54



No. 190

Ice Box Drip Sink. Extra deep bowl. 2-inch waste, 4 in. trap, 3 in. side clean-out.
Diameter, 12 in.
Depth, 6 in.
Outlet tapped 2 in.
List \$11.00

ICE BOX DRIP BASINS AND TRAPS

To meet requirements of different codes and building construction.



No. 178

Drip Pan.
Tapped 1½ inch.
Diameter, 6½ inches.
List \$0.80



No. 175-A

Drip Pan.
Removable Seal, ¼ inch.
Tapped, 1¼ or 1½ inches.
Diameter, 8 inches.
List \$1.06



No. 175

Drip Pan.
Seal, ¼ inch.
Tapped, 1½ inches.
Diameter, 9 inches.
List \$1.90



No. 104

Drip Pan and Trap.
Seal, 1 inch.
Tapped, 1½ inches.
Diameter, 5 inches.
List \$1.70



No. 105-A

Drip Pan and Trap.
Seal, 2 inches.
Tapped, 1½ inches.
Diameter, 6 inches.
List \$2.40



No. 65-67

Loose Funnel with Trap.
Seal, 2 inches.
Tapped, 1½ inches.
Body, 2½x8 inches.
List \$3.78



No. 150-241

Floor Drip Pan.
Diameter, 14 inches.
Depth, 3½ inches.
Outlet Slips, 3 or 4 inch soilpipe.
Used with ordinary cast P. Trap.
List, 3 in. \$3.80
List, 4 in. \$4.30

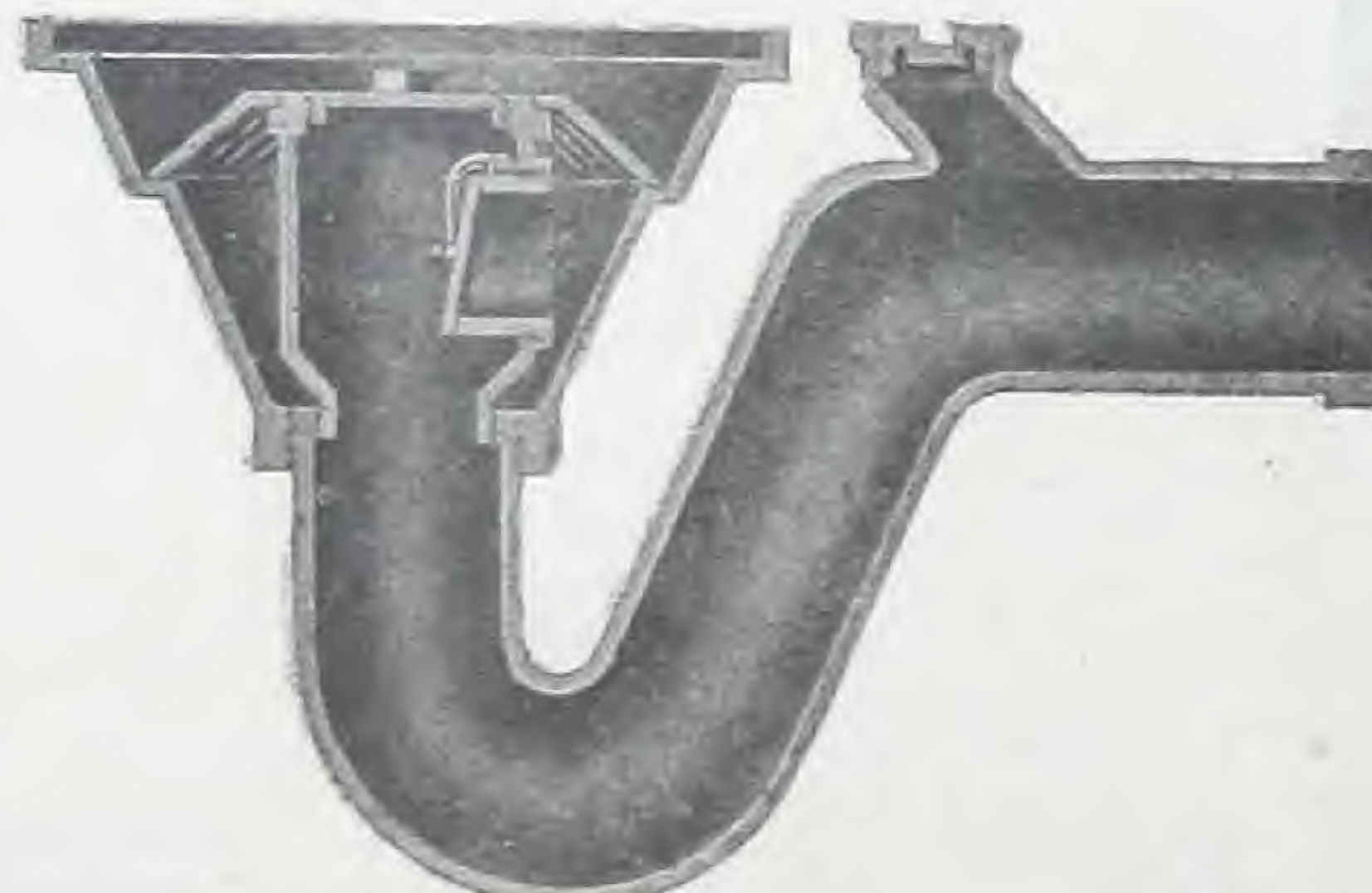

No. 108-B

Drip Pan and Back Pressure Trap.
Diameter, 12 inches.
Outlet, 2 or 3 inch.
Depth of Seal, 4 inches.
List, 2 inch. \$11.90
List, 3 inch. \$16.20



No. 180

Floor Drain.
Diameter, 12 inches.
Depth, 10 inches.
Outlet Slips either 3 or 4 inch soilpipe.
List \$9.80

GREENWOOD MFG. CO.

5140 HAMILTON
AVENUE

Detroit, Mich.

BUILT IN BATH TUB SUPPORT

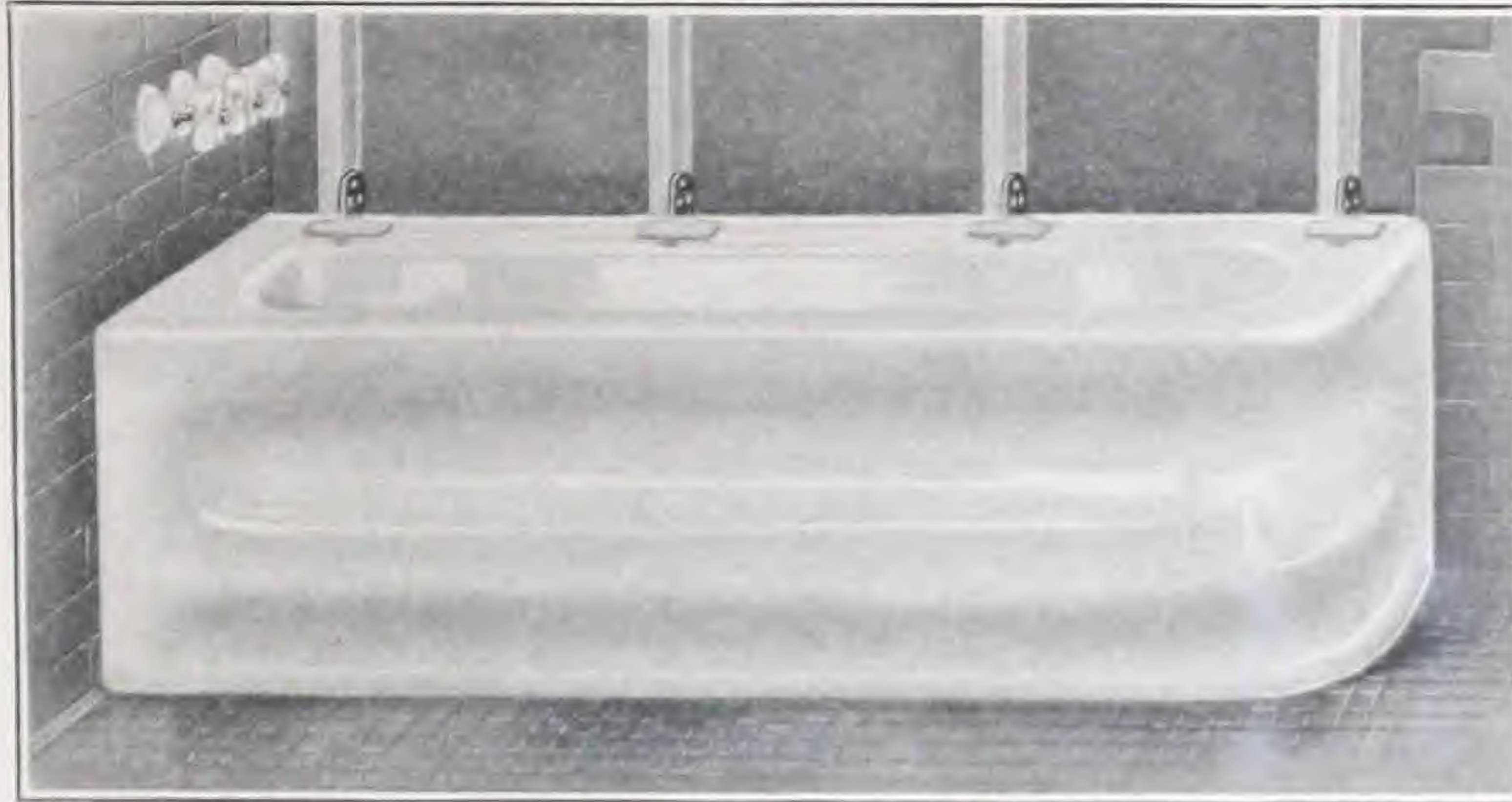

Plate No. 1000

Cast Iron support placed under rim of built in bath tubs and fastened to studding holds the tub securely in place assuring a permanently tight joint between tub and finished wall.

Complete, with screws List, \$.50 each

[BLANK PAGE]



CCA

GREENWOOD MANUFACTURING CO., DETROIT, MICH.

Greenwood Manufacturing Co.

Detroit, Michigan

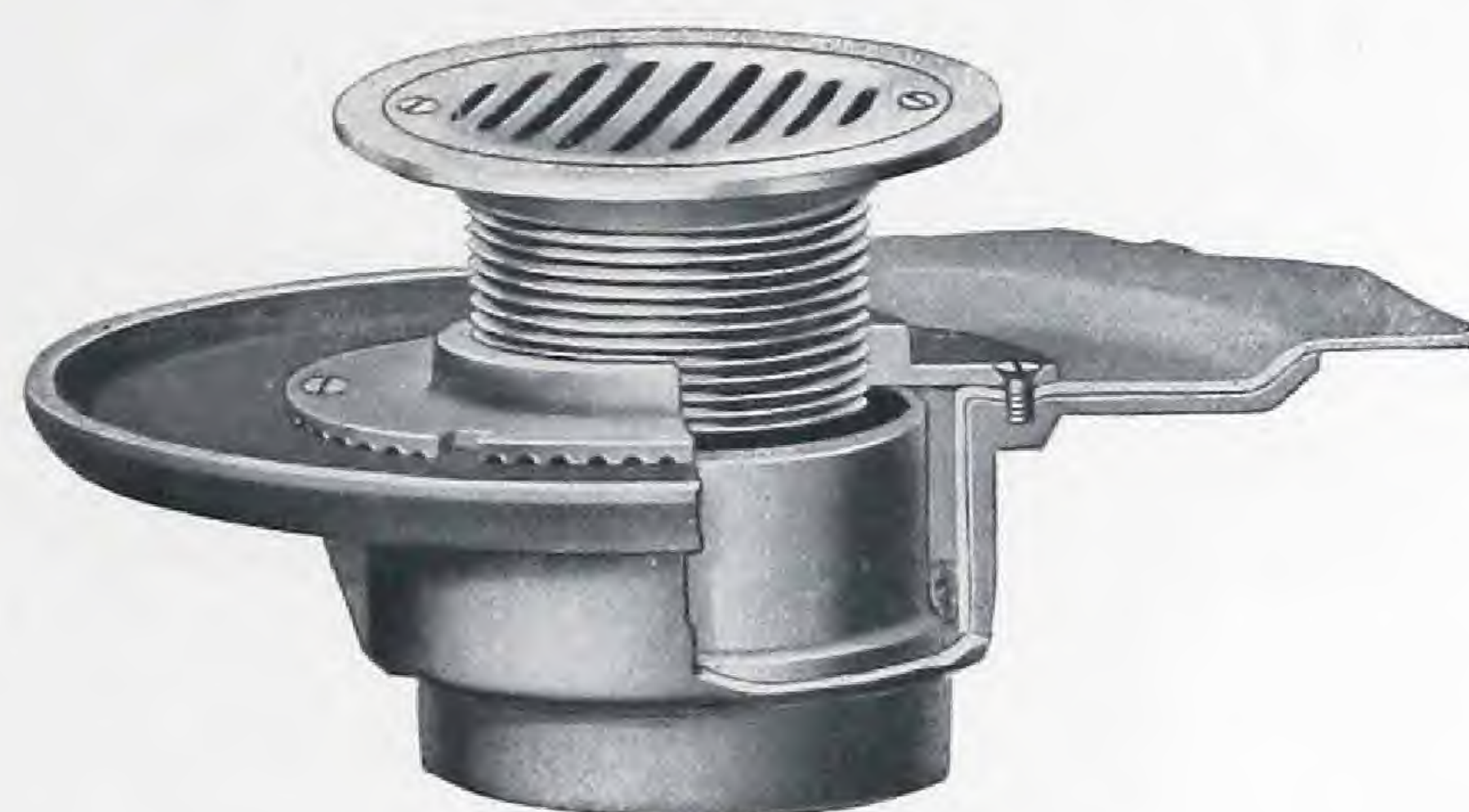

1924
CATALOGUE

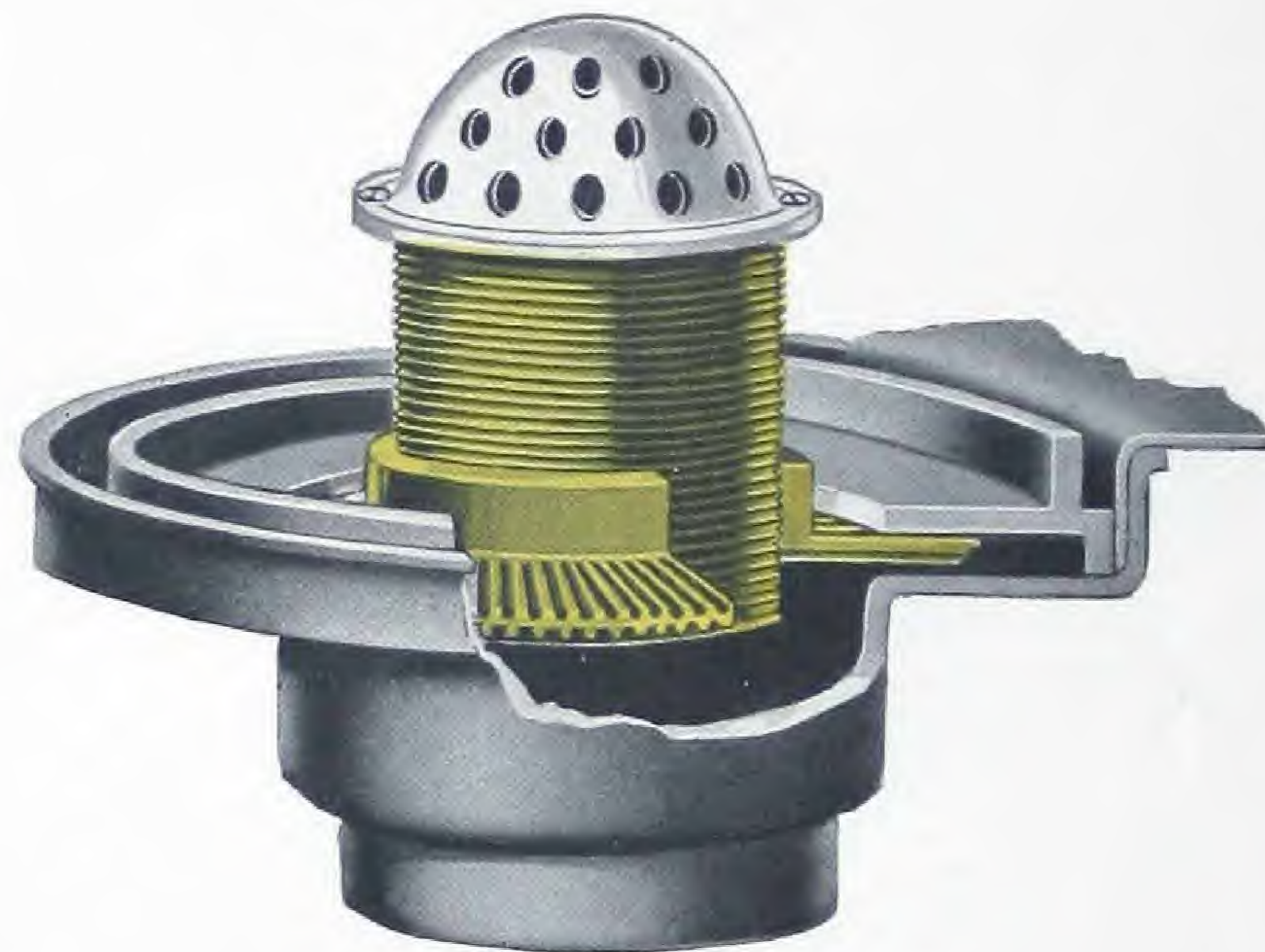

No. 135

Brass and Iron
Seepage Urnal Drain

Adjustable "S" Trap No. 63

Cast iron. Deep seal, adjustable centrifugal "S" trap. This trap will stand all kinds of abuse and we recommend it for factories or any place having an exposed waste to floor.

Trap painted aluminum bronze.
Waste connections, 1½ inches.



No. 63

Adjustable "P" Trap No. 60

Cast Iron. Deep seal, adjustable centrifugal "P" trap with cleanout opposite waste outlet. Designed for easy installation and the lowest upkeep cost.

Trap painted aluminum bronze.
Waste connections, 1½ inches.



No. 60

Adjustable "P" Trap No. 68

Cast iron. Deep seal, adjustable centrifugal trap with brass union connection in center. This is a swell looking trap for roll-rim sinks. Easier than brass to keep clean and gives equal service.

Trap painted aluminum bronze.
Waste connections, 1½ inches.



No. 68

One Piece "P" Trap No. 66

Cast iron. Centrifugal basin trap. This trap makes a neat appearing job for apartment house work and will cost the owner very little for upkeep.

Furnished with N. P. jam nut, 1¼x1½ or 1½x1½.
Trap painted aluminum bronze.
Waste connections, 1½ inches.



No. 66



No. 38-39

Bath Trap No. 38-39

Cast iron. Size 4x5 inches. Cleanout tapped 3" std. iron pipe thread and fitted with brass plug with oblong head. The inlet connection is fitted with return bend, the centers of which are 5". This design takes up the least amount of space when screwed in place. The total length of trap is 7½ inches.

Waste connections, 1½ inches.



No. 39-A

Bath Trap No. 39-A

Cast iron. Size 4x5 inches. Cleanout 3" I. P. brass with either raised or countersunk head, tapped in center for ¼ inch brass bolt, which allows the N. P. top cover to be extended up to 2¼ inches above trap if necessary. For double floors the extension cover makes this trap much easier to install.

Waste connections, 1½ inches.



No. 4-A

Bath Trap No. 4-A

Cast iron. Size 3x6 inches. The inlet connection is fitted with a special short 1½-inch street ell. For built-in tubs, this trap, being adjustable and specially constructed for close roughing in or extension connections and usable with either a brass plug or N. P. cover, is an easy trap to install.

Cleanout and waste connections tapped 1½ inches.



No. 4-B

Bath Trap No. 4-B

Cast iron. Size 3x6 inches. The inlet connection is fitted with return bend, the centers of which are 5 inches. Where tub on legs is installed, a N. P. cover is used in place of the brass plug. The trap body is faced on both ends and the outlet tapping is 1 inch off center, so that by reversing the trap body it will extend up flush with floor line of double floors.

Total length of trap, including return ell, is 8 inches. Cleanout and waste connections tapped 1½ inches.

Bath Trap No. 33

Cast iron. Size 4x8 inches.

Cleanout fitted with 3" I. P. size brass plug and to it is secured by a brass screw a 5½-inch N. P. flat top cover, without a recess to catch dirt or a raised head to stumble over.

Waste connections tapped 1½ or 2 inches.



No. 33

Bath Trap No. 20

Cast iron. Size 4x6½ inches. This length allows the trap to be placed where the joists are only 6 inches, a condition that often arises. The feature of having the N. P. cover secured to trap with bolt extension means that the cover will fit tight to floor if the trap itself does tilt a little.

Waste connections tapped 1½ inches.



No. P-20

Dentist Cuspador Trap No. 44

Cast iron. Size 4x8 inches.

Connection is made through the 5-inch brass N. P. cover with N. P. jam nut.

Waste outlet connection tapped 1½ or 2 inches.



No. 44

Bath Trap No. 45

No matter how much lower the ordinary traps may be in first cost, there are three good and sufficient reasons for using this trap in all apartment house and hotel work. First, the centrifugal flow of water, whirling and driving through the trap, keeps it free from stoppage much longer than is possible with any straight inlet trap.

Second, in cement construction, should the trap when set extend above floor line, it may be cut off flush with floor, the upper portion of trap being threaded to a depth of 2½ inches.

Third, get-at-able traps with large cleanouts pay for themselves many times over in low upkeep costs.

This trap is furnished with either N. P. cover or 3" brass plug.

Waste connections tapped 1½ inches.



No. 45



No. P-30

Pot Trap No. 30

Cast iron. Size 4x6½ inches or 4x8 inches, with 3" I. P. size brass plug. Note the oblong head on the cleanout. It can be removed with monkey wrench without a chance of damaging the plug by rounding the corners of the raised head.

Waste connections tapped 1½ or 2 inches.



No. P-31

Pot Trap No. 31

Cast iron. Size 4x6½ inches. Cleanout threaded 3 inches.

Waste connections tapped 1½ inches.



P-41

Pot Trap No. 41

Cast iron. Size 4x7 inches. The 3-inch cleanout is placed in front of trap and below the seal. This makes a desirable trap for all low fixtures.

Inlet openings, 1½ inches; outlet, 1½ or 2 inches.



No. P-57

Pot Trap No. 57

Cast iron. Size 4x7 inches.

Where a top cleanout can be conveniently used, a neat appearing job is easily made with this trap.

Cleanout, 3 inches.

Waste connections tapped 1½ inches.

Brass Top Bell Traps No. 852-A

Iron bodies. Outlets tapped 1½, 2 or 3 inches. The brass cover is secured to body by four brass screws. The heavy brass strainer is hinged to the brass plate.

Size of top plates, 6x6 or 9x9 inches. Polished tops.



No. 852-A

Putty Cup Tail Pieces P. 80

Cast white metal or drawn brass tubes.
Jam nuts are nickel plated.

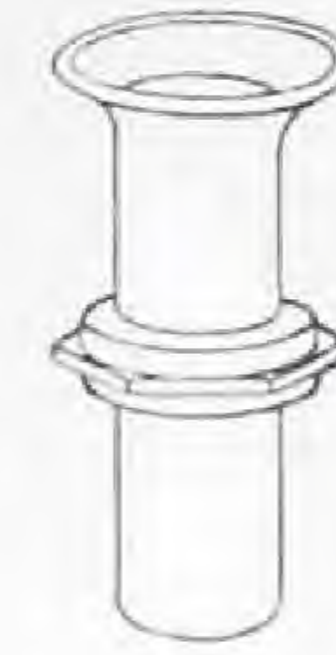

No. P-80

G. J. Waste Connections

Adjustable ground joint connections were first used for making gasoline and air connections on automobile engines. Having proved successful in actual use on gasoline and air lines, we adopted the same method for connecting brass tubing to iron waste, and nothing that has so far been devised compares in security, cost of installation or appearance with this method of connecting N. P. trap to waste pipes.

The fact that this connection will hold a fifty-pound air test, is indestructible and easily connected or disconnected, makes it an ideal fitting for drainage construction in all large buildings.

FEMALE	MALE
645 No. 1—1¼x1¼	646 No. 1—1¼x1¼
645 No. 2—1½x1¼	646 No. 2—1½x1¼
645 No. 3—1½x1¾	646 No. 3—1½x1¾
645 No. 4—1½x1½	646 No. 4—1½x1½



No. 645



No. 646



No. 178

Ice Box Drip No. 178

Cast iron.

Diameter, 6½ inches.

Depth, 1⅞ inches.

Threaded for 1½-inch iron pipe.



No. 175-B

Ice Box Drip Trap No. 175-B

Cast iron.

Diameter, 7 inches.

Depth, 3 inches.

Seal, 1 inch.

Waste outlet, 1¼ inches.

The feature of having a horizontal tapping for drip sink often saves a lot of time.



No. 175

Ice Box Drip Trap No. 175

Cast iron.

Diameter, 9 inches.

Depth, 2½ inches.

Seal, 1 inch.

Waste outlet, 1½ inches.

One-piece drip traps are by far the most reliable. They provide a permanent seal.



No. 105-A

Ice Box Drip Trap No. 105-A

Cast iron.

Diameter of top, 6 inches.

Depth, 8 inches.

Seal, 2 inches.

Waste outlet, 1½ inches.

This trap, placed at floor line, makes it easy to clean under ice box and there is no place to catch dirt. We recommend it for all apartment house ice boxes.

Drip Basin No. 150-241

Cast iron. Diameter, 14 inches. Depth, 3½ inches.

Cast to basin is an iron hub to slip either 3-inch or 4-inch pipe, and fitted inside of the hub is a removable iron grate.



No. 150-241

Drip Sink No. 192-66

Cast iron.
Diameter, 12 inches.
Furnished with cast iron centrifugal deep seal "P" trap with cast brass cleanout. Outlet tapped 1½ inches.

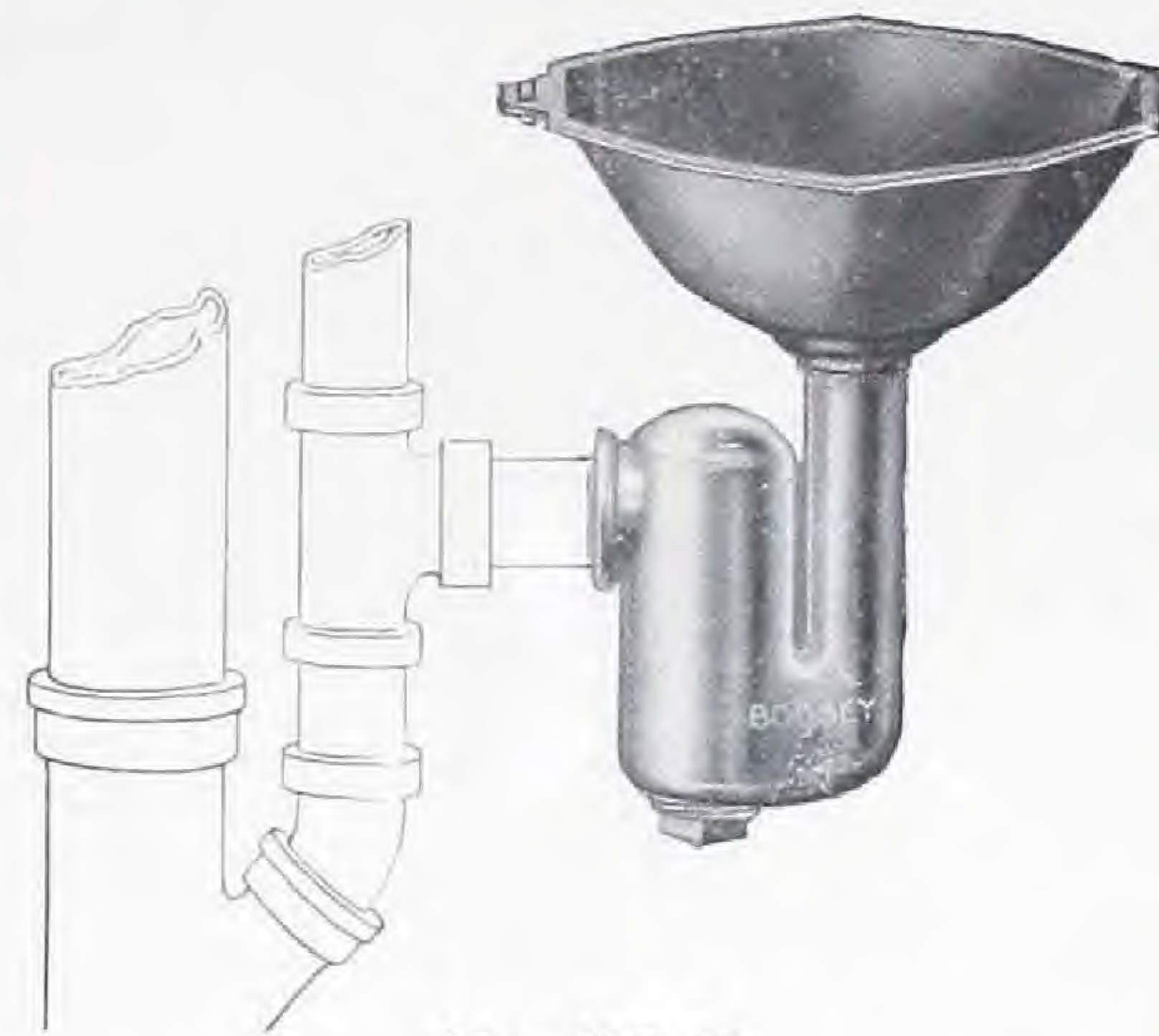

No. 192-66

Drip Sink No. 191

Cast iron. Size 12x12 inches. Tapped 1½-inch outlet. No brackets are required with sink. It is secured to wall through the elevated back by two screws, which hold it secure. The appearance of the fixture, when installed, justifies the additional cost.



No. P-191

Drip Sink and Back Pressure Trap No. 108-B

Cast iron, with brass back pressure valve and 5-inch water seal.

Made in two sizes, 2 or 3 inches.

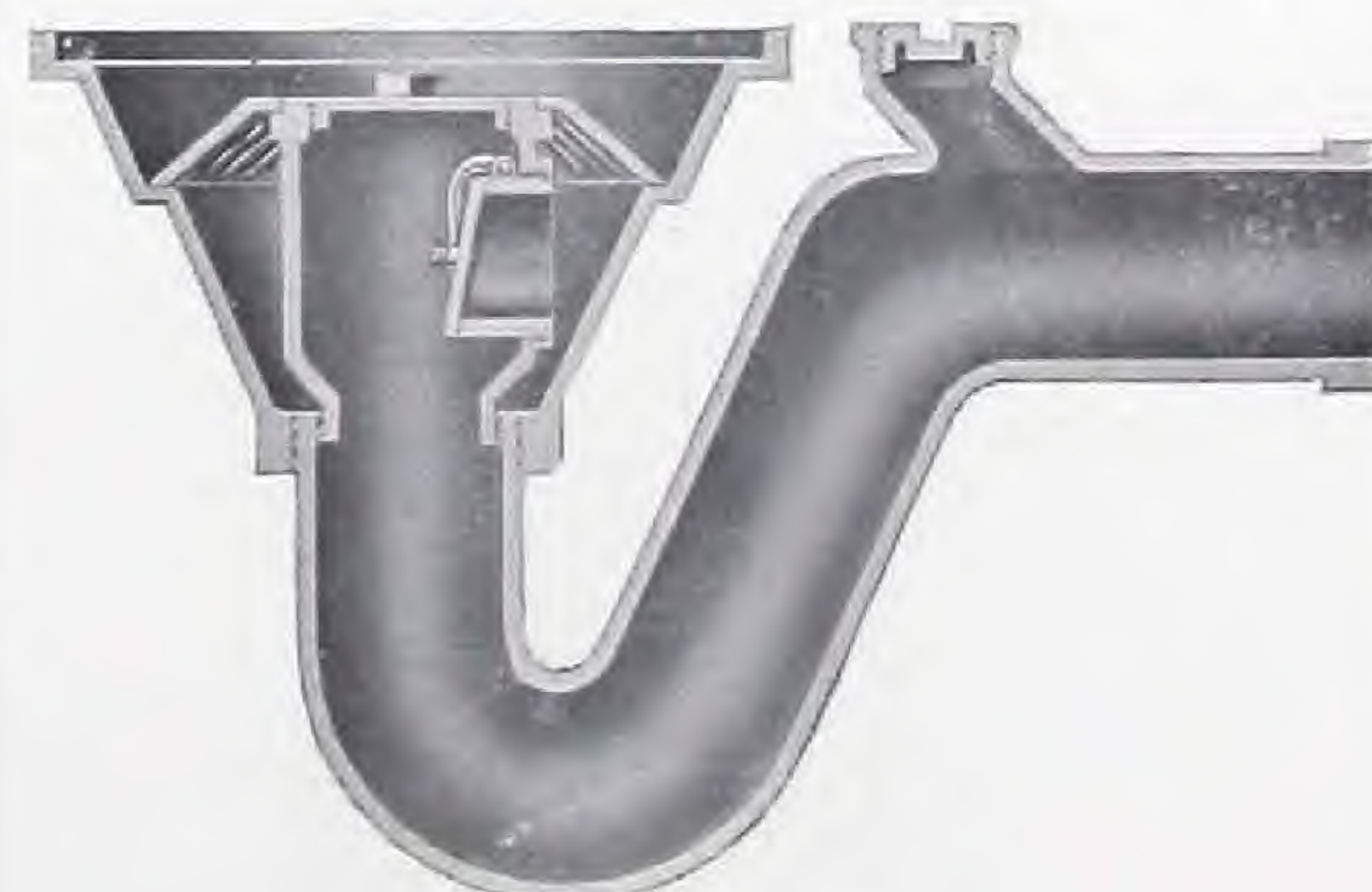

No. 108-B



No. 70

“P” Trap No. 70

Iron bodies, deep seal, low inlets.

They can be used in connection with any type of drain head.

Made in three sizes, 1½, 2 and 3 inches.



No. 70-91-2

Floor Drain No. 70-91-2

Iron body, fitted with 5-inch N. P. brass bar strainer and brass cleanout plug. Tapped 2 inches.



No. 70-92

Floor Drain 70-92

Cast iron. 9-inch drain head with anchor cast to body. Fitted with a 9-inch finished brass top with hinged strainer. Trap tapped 3 inches, either with or without cleanout.



No. 70-96-97

Factory Floor Drain 70-96-97

Cast iron. For heavy traffic. 9-inch drain head, with double anchors and hinged brass or iron strainer ½ inch thick.

Trap tapped 3 inches, with or without cleanout.

Shower Trap No. 122

Body 4x8 inches, fitted with 9-inch loose flanged hub anchor. The lead pan may be turned down into the hub and calked, making a positive water-tight joint between lead pan and trap.

Waste connection tapped 1½ or 2 inches. Strainer, brass N. P. Diameter, 5½ inches.



No. 122

Shower Trap No. 120

Same as the No. 122, with the exception of waste outlet.



No. 120

Shower Trap No. 121

Same as the No. 122, with the exception of waste outlet.



No. 121

Shower Trap No. 125

Iron body, 4x6½ inches. Hub flange cast with trap body. Iron ferrule forms calking recess for permanently securing lead pan to trap body.

Strainer, brass N. P. Diameter, 5½ inches. Outlet tapped 2 inches.



N. 125

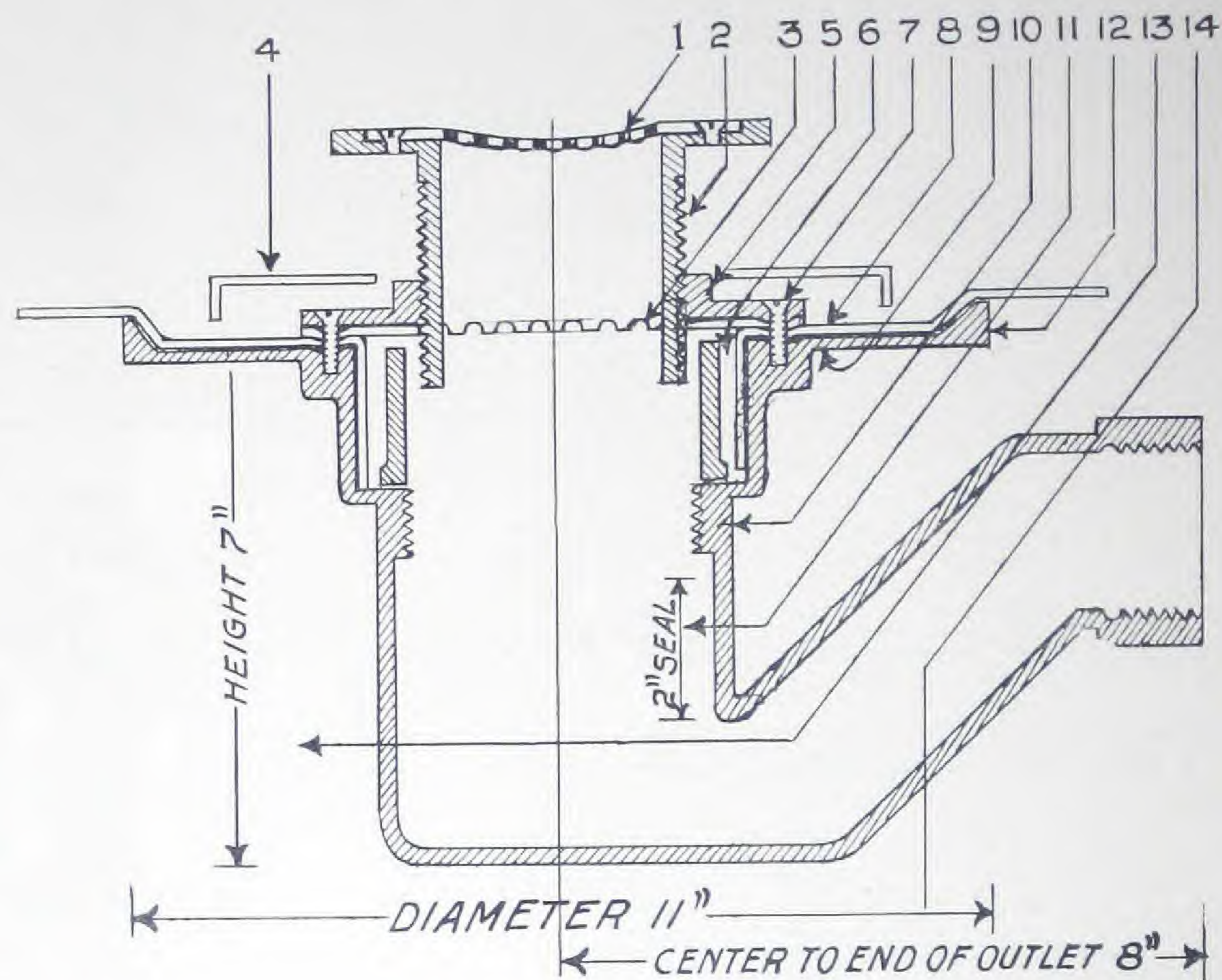

Shower Traps or Floor Drains No. 126-130

- No. 1. Brass bar strainer N. P. Diameter 5 inches and secured to brass extension tail piece with removable brass screws.
- No. 2. Brass tail piece $2\frac{1}{2}$ inches long and threaded 3-inch iron pipe size.
- No. 3. Shows the grooves on the under side of seepage plate through which the seepage drains back into trap.
- No. 4. Loose pulp guard placed over seepage holes to prevent them being filled with cement.
- No. 5. Seepage plate tapped 3-inch, connects the tail piece to trap body, with a screwed joint, the seepage plate being placed over the lead pan and connected to trap body by four brass bolts.
- No. 6. Recess formed in the upper portion of trap into which the lead pan is secured to trap body by a calked joint.
- No. 7. Brass bolts that secure the seepage plate to trap.
- No. 8. Lead pan which is permanently secured to trap by a calked joint.
- No. 9. Cast anchor which securely holds the trap body into the cement and forms a basin for the seepage waste.
- No. 10. Threads in the upper portion of trap for securing iron plug for the rough test. The plug also prevents dirt entering trap and waste line during building construction.
- No. 11. Depth of water seal in 2-inch trap 2 inches.
Depth of water seal in 3-inch trap 3 inches.
- No. 12. Ring forming basin of trap anchor.
- No. 13. Height of iron body 2-inch trap 7 inches.
Height of iron body 3-inch trap $10\frac{1}{2}$ inches.
- No. 14. Outside diameter of flange 11 inches.

Patented December 29th, 1923.

Seepage Shower Trap No. 126-130

Cast iron body with 5½-inch N. P. adjustable strainer. The upper portion of trap forms a hub into which the lead pan is permanently calked to trap body, making an absolutely water tight installation of shower trap.

Made in two sizes, 2 or 3-inch.



No. 126-130

Seepage Shower Trap No. 126-131

Cast iron body and strainer. Diameter of head 9 inches. Depth of strainer 1¾ inches. For factory wash rooms or showers and may be used either with or without lead pan.

Made in two sizes, 2 or 3-inch.



No. 126-131

Seepage Shower Trap No. 126-132

Cast iron body with 9-inch polished brass top with hinged strainer. May be used with or without lead pan. Made in two sizes, 2 or 3-inch.



No. 126-132

Seepage Shower Trap No. 126-132 B. W.

Cast body with 9-inch polished brass top and hinged strainer. This trap is made for basement showers and is fitted with back water valve.

Made in 2-inch.



No. 126-132 B. W.

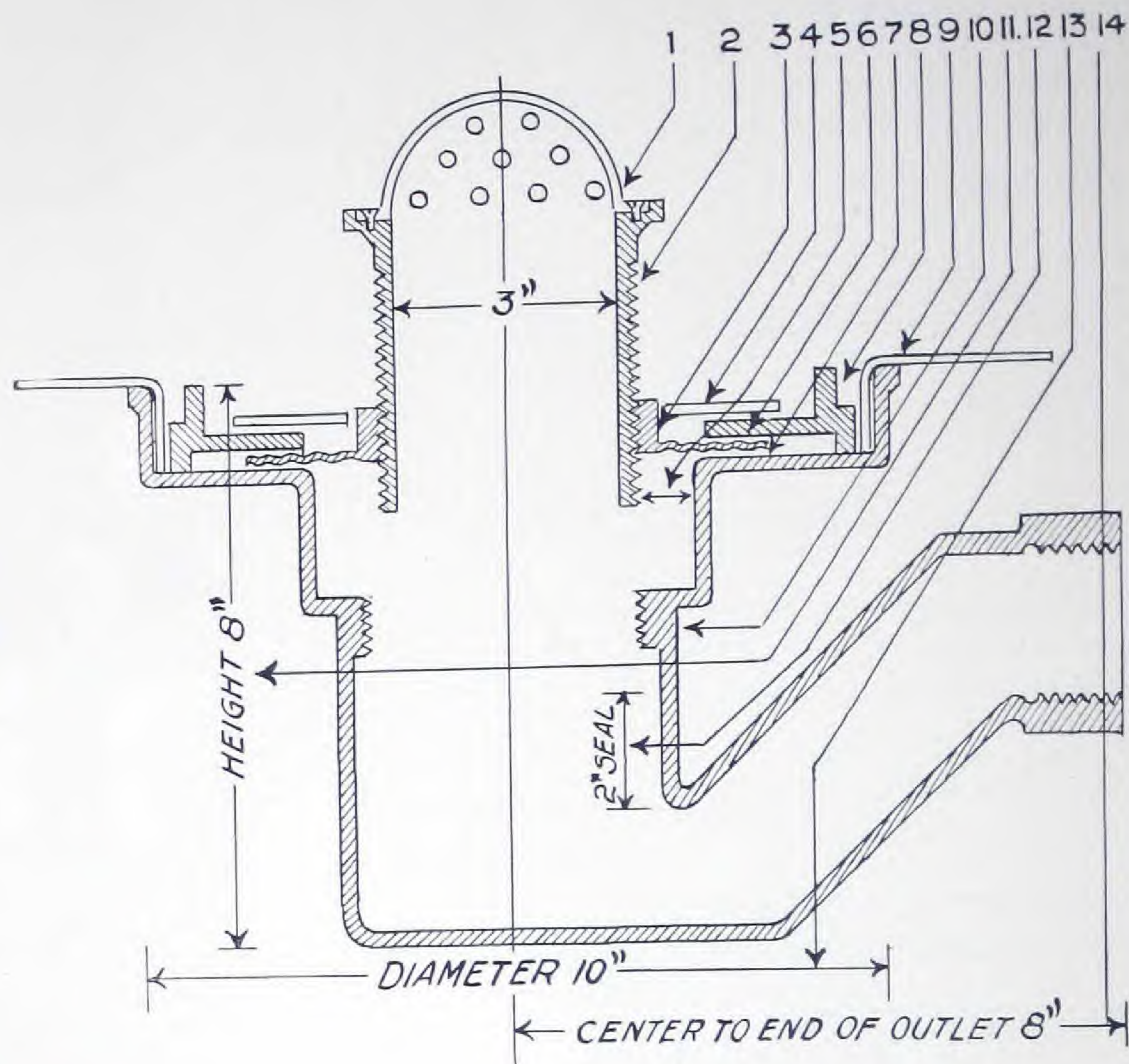

Seepage Urinal Trap No. 126-135

- No. 1. Brass N. P. beehive strainer secured to tail piece with removable brass screws.
- No. 2. Extra long brass urinal tail piece, length $4\frac{1}{2}$ inches, threaded 3-inch standard iron pipe size.
- No. 3. Seepage plate. Red brass, diameter 6 inches with grooves top and bottom of plate allowing seepage to pass over and under plate and drain back into waste.
- No. 4. Loose pulp guard placed over seepage holes to prevent them being filled with cement.
- No. 5. Shows space into which the urinal tail piece may be adjusted either vertically or horizontally.
- No. 6. Adjustment plate which securely holds the brass seepage plate in place but allows the plate to be moved in any horizontal direction for centering the waste connection to urinal.
- No. 7. Space under the adjustment plate permitting shifting of seepage plate for centering urinal tail piece.
- No. 8. Recess formed by adjustment plate for securing the lead pan and adjustment plate to trap with calked joint.
- No. 9. Lead pan which is permanently secured to urinal trap with a calked joint.
- No. 10. Threads in the upper portion of trap for securing an iron plug for rough test. The plug also prevents dirt entering trap and waste line during building construction.
- No. 11. Height of 2-inch trap 8 inches.
Height of 3-inch trap $11\frac{1}{2}$ inches.
- No. 12. Depth of seal in 2-inch trap 2 inches.
Depth of seal in 3-inch trap 3 inches.
- No. 13. Outside diameter of flange 10 inches.
- No. 14. Center to end of outlet 8 inches.

Patented December 29th, 1923.

Urinal Waste Connection

Self centering.

Seepage drainage.

Lead pan connection.

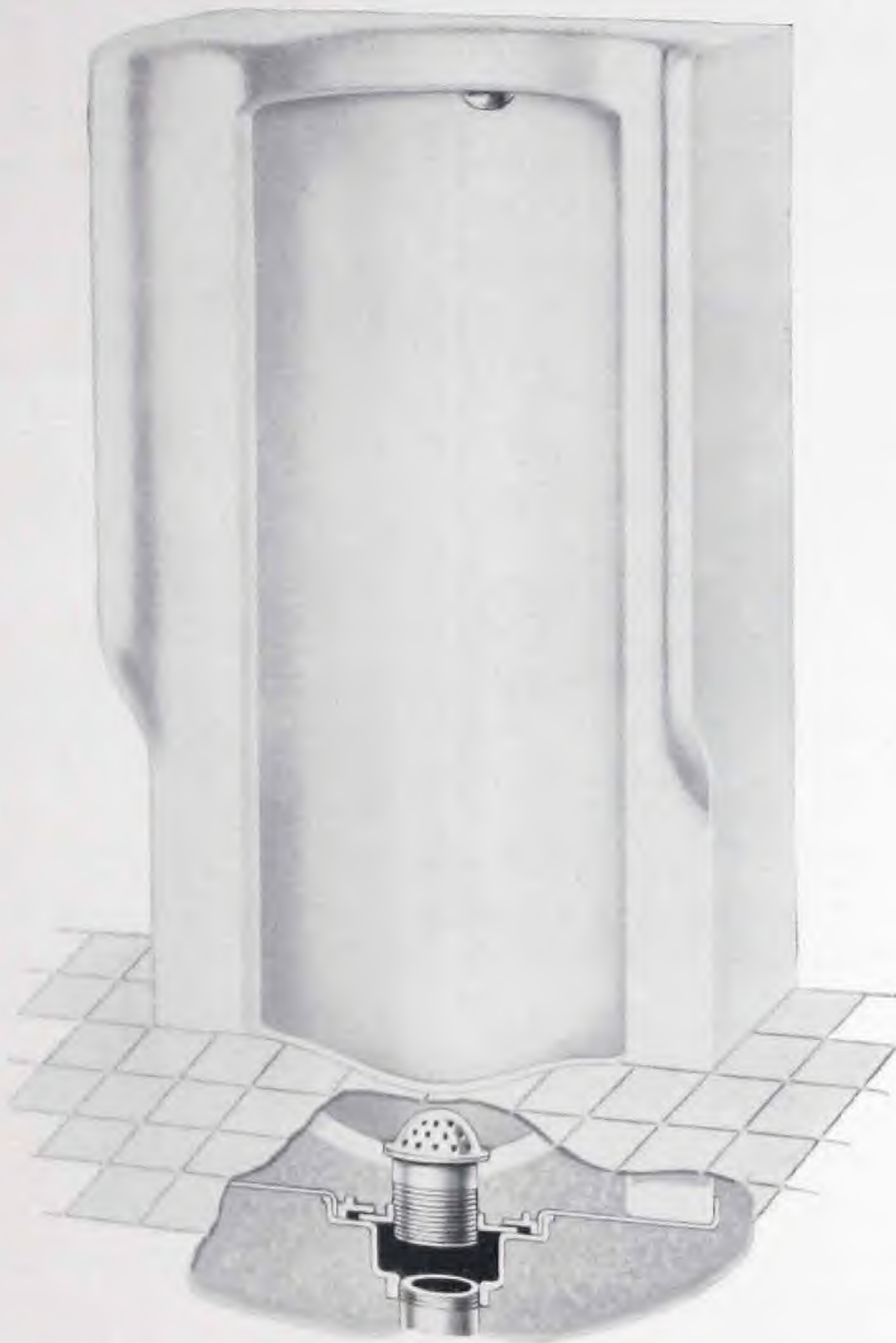

No. 135

The illustration shows a typical installation of drain for porcelain urinal stall. The advantage of this connection is that it can be adjusted after the fixture is placed.

The brass adjustment plate is ribbed on both sides, allowing seepage to pass over and under plate and back into trap.

The lead pan is securely connected to trap by calking into outer recess. When placing urinal be sure that the seepage receptacle is filled with cement.

2-Inch Urinal Trap



No. 126-135-2"

3-Inch Urinal Drain Head



No. 135

3-Inch Urinal Trap



No. 70-135-3"

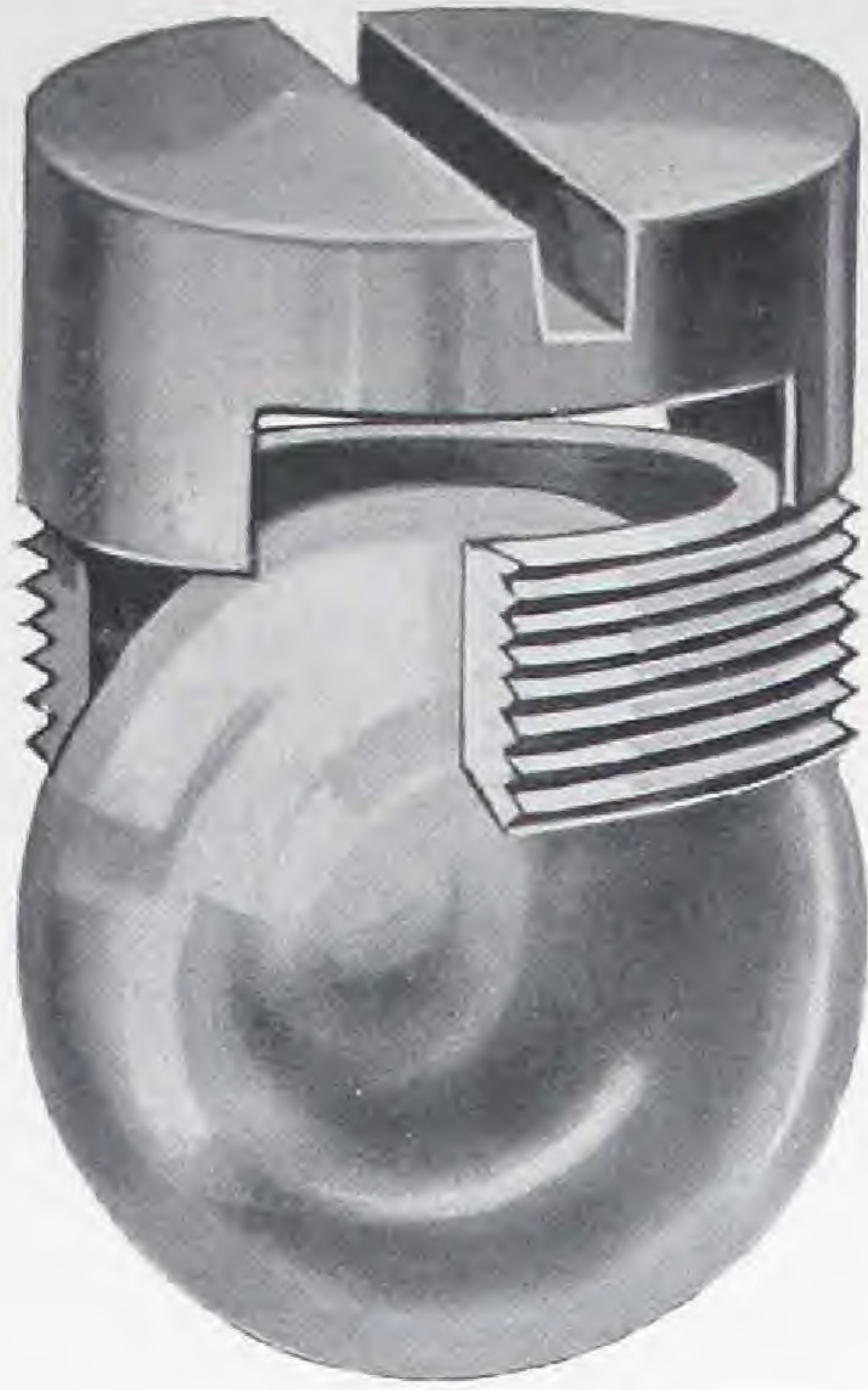

Iron Strainer



No. 115

Brass Top



No. 115

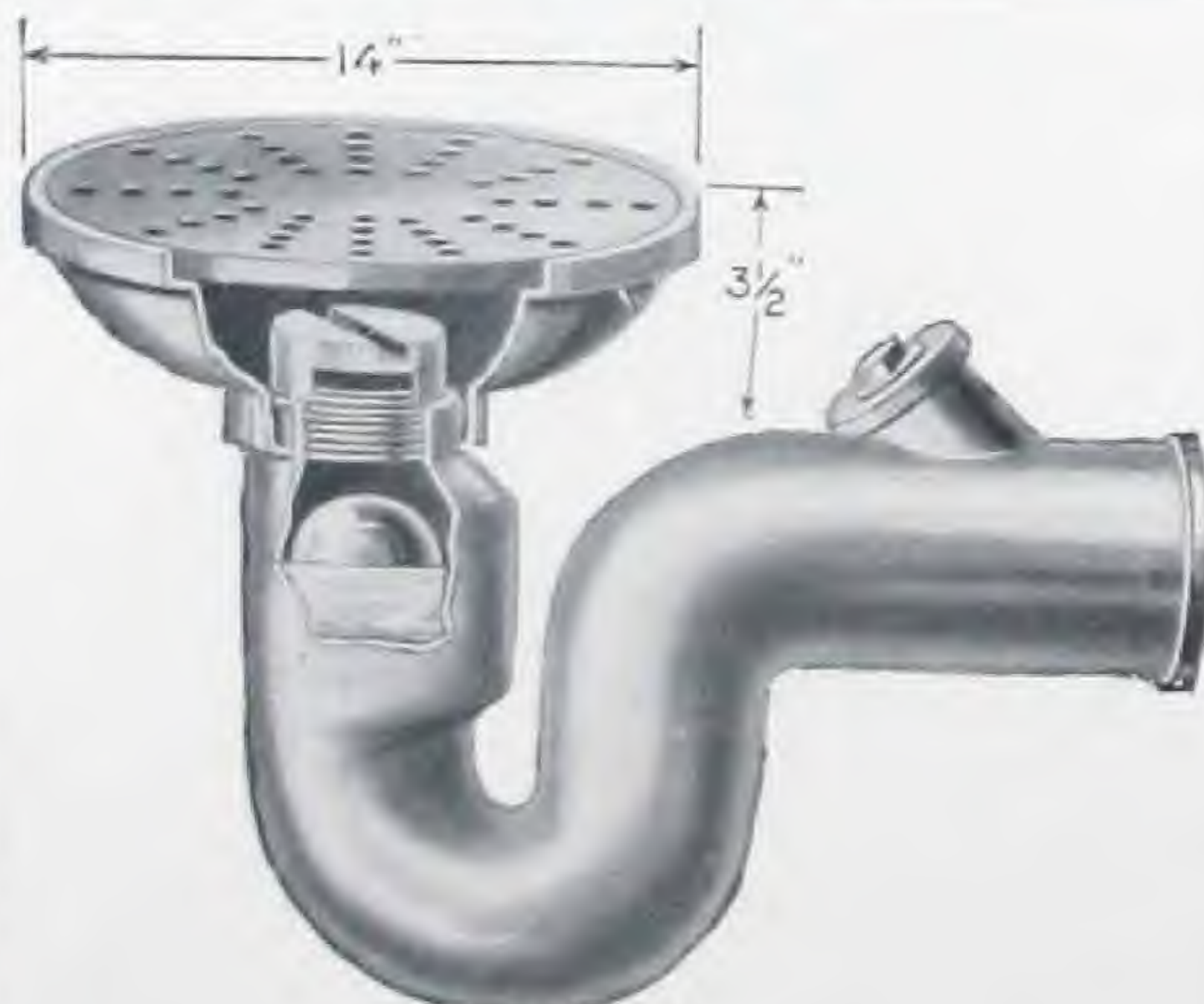

No. 112

Back Water Floor Drain

Every element in construction bears evidence of its ability to perform the work for which it is intended. It also embodies several old-fashioned ideas of what is required to make a floor drain something better.

This trap is constructed with brass cleanout and full 4-inch water seal, enlarged float chamber, an 8-inch heavy trussed strainer held in place with a brass bolt, a removable bronze brass valve with ground seat and covered top to protect float.

Compare it in construction with the cheaper makes having shallow water seal, small loose covers, no cleanout and open top valve with rubber seat.

Competition traps at a lesser price are made with the least possible seal. The light, loose covers become broken or lost and, having no cleanout, it is sometimes necessary to break up the cement floor to remove stoppage from waste line. Open top valves provide no protection for copper float which becomes dented and useless, and the substitution of a rubber seated valve for a ground brass seat only shortens the life of the floor drain. Last but not least, cheap constructed floor drains are a constant annoyance and expense to the owner.

The No. 115 is made in two sizes, 2 or 3-inch with iron covers, or brass covers with hinged strainers.

The No. 112 is made only in 4-inch.

Back Pressure Floor Drains

There is a vast difference between a back water floor drain and a back pressure floor drain.

In a back water floor drain, should the water seal become broken there is nothing to prevent sewer air passing through the trap into the building.

In a back pressure floor drain, should the trap lose its seal from any cause, the bronze metal swing valve, being always set in a closed position, prevents the free back-flow of sewer air into the building.

The swing valve is placed on the house side of trap, above the water seal where it is always accessible for cleaning or inspection.

This floor drain is recommended for cooling rooms in creameries or slaughter houses, storage rooms in packing houses, refrigerated storage rooms in hotels and stores, and for ice box drip sinks.

Made in the following sizes:

- No. 111, 4-inch.
- No. 108, 2, 3 and 4-inch.
- No. 108B, 2 and 3-inch.

The No. 111 double valve floor drain is designed specially for use in deep basements.

Furnished with polished brass tops and hinged strainers when specified.



No. 111



No. 108



No. 108-B



Drain Head No. 91

Iron body tapped 2 inches, depth 2 $\frac{1}{2}$ inches.

Fitted with 5-inch N. P. brass ring and strainer secured to iron body with two brass screws.



Drain Head No. 124

Iron body tapped 3 inches, depth 3 inches.

Fitted with 5-inch N. P. brass ring and strainer secured to iron body with two brass screws.



Drain Head No. 94

All brass with N. P. top, threaded for 3-inch std. iron pipe. Length of thread 2 inches. Diameter of strainer 5 $\frac{1}{2}$ inches. Length over all 3 inches. Strainer secured to body with brass screws.



Drain Head No. 95

All brass with N. P. top, threaded for 2-inch std. iron pipe. Length of thread 1 $\frac{1}{2}$ inches. Diameter of strainer 5 $\frac{1}{2}$ inches. Length over all 2 $\frac{1}{2}$ inches. Strainer secured to body with brass screws.

Drain Head No. 92

Iron body, tapped 3 inches. Depth 4 inches. Fitted with 9-inch finished brass top with hinged strainer secured to iron body with brass screws.



No. 92

Drain Head No. 96

Iron body tapped 3 inches. Diameter 8 inches. Depth 4 inches. Fitted with iron or brass strainer 1/2-inch thick hinged to body with brass bolt.



No. 96

Drain Head No. 863-B

Iron body, depth 4 1/2 inches. Diameter 9-inch with iron strainer or all brass top with hinged strainer. Outlet tapped 3-inch inside and fitted with 3-inch brass plug with oblong raised head.



No. 863-B

Drain Head No. 100

Iron body. Length 12 inches. Outlet 3-inch X. H. to calk into hub. Top fitted with 9-inch round or square finished brass ring with hinged strainer secured to iron body with brass screws.



No. 100



No. 130

Seepage Shower Drain Head No. 130

Cast iron body with 5½-inch N. P. adjustable strainer. The upper portion of drain head forms a hub into which the lead pan is permanently calked to drain head, making an absolutely water-tight installation. Made in two sizes, 2 and 3-inch.



No. 131

Seepage Shower Drain Head No. 131

Cast iron body and strainer. Diameter of head, 9 inches. Depth of strainer, 1½ inches. For factory washrooms or showers. May be used either with or without lead pan. Outlet tapped 3-inch.



No. 132

Seepage Shower Drain Head No. 132

Cast iron body with 9-inch polished brass top with hinged strainer. May be used with or without lead pan. Outlet tapped 3-inch.



No. 135

Seepage Urinal Drain Head No. 135

This waste connection between urinal and trap is provided with seepage drain openings, a positively water-tight, calked joint connection secures the lead flange permanently to the drain head. The waste connection to drain head has a total horizontal adjustment of 1½ inches and a vertical adjustment of 2 inches. All urinal drain heads are tapped for 3-inch pipe. Measurements are the same as shown on page 12.

Seepage Factory Floor Drain No. 163. Iron Top

Cast iron. Fitted with anti-tilting slip cover $1\frac{3}{4}$ inches deep. The outer edge of seepage flange is tapped for adjustment bolts.

The drain is also provided with dirt trap, which prevents metal cuttings and sticks from entering waste line. Hub outlet made to slip either cast or wrought pipe or tapped for screw thread.

Waste outlet either 3 or 4 inches.

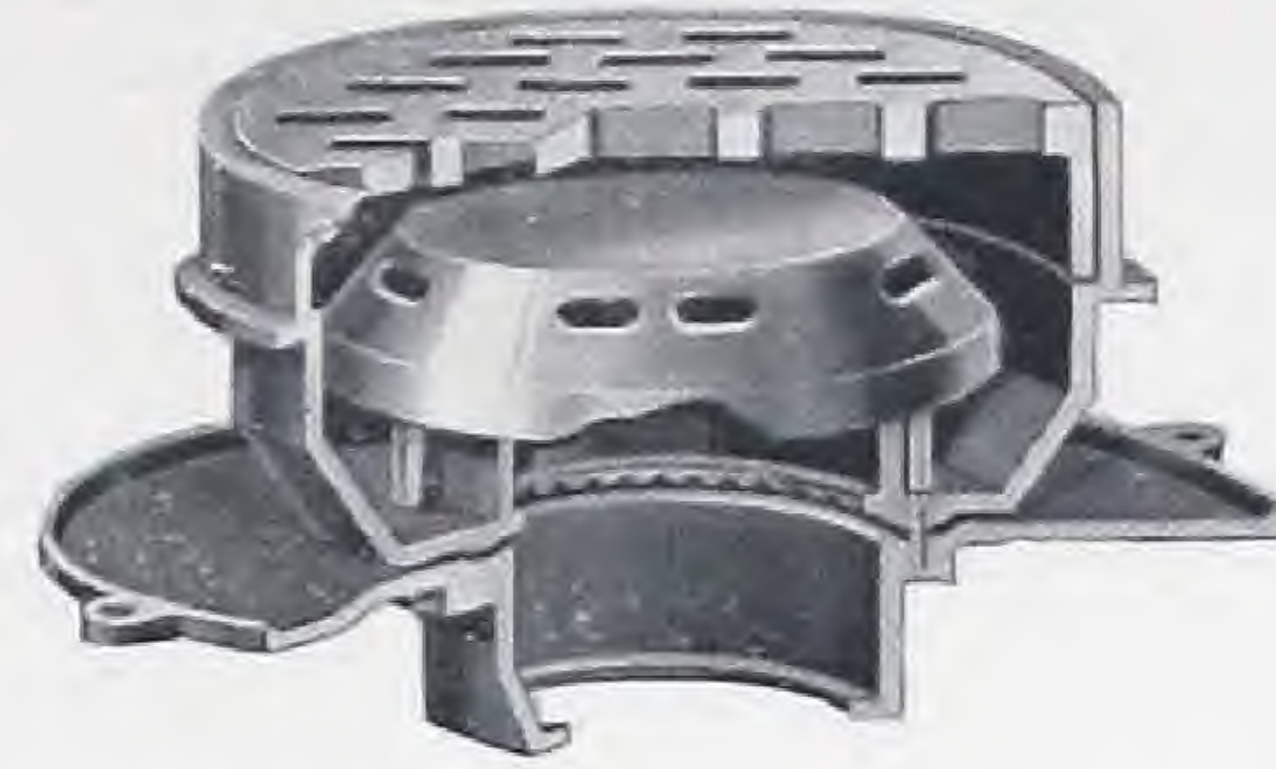

No. 163—Iron Top

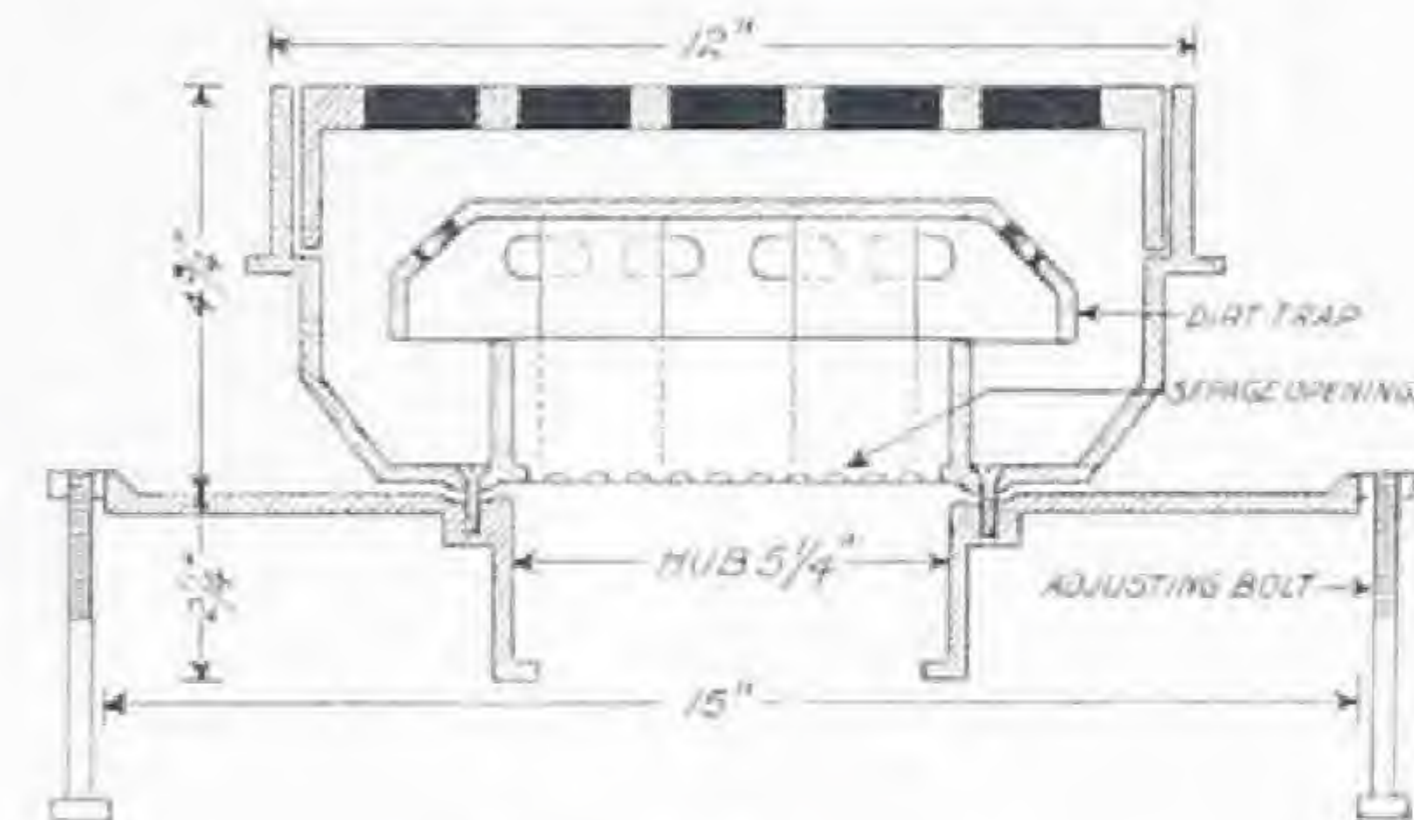

No. 163

Seepage Factory Floor Drain No. 163. Brass Top

Iron body with finished red brass top and hinged strainer. Diameter of brass ring, 12 inches.

Diameter of hinged strainer, $9\frac{1}{2}$ inches.

Thickness of ribbed strainer, $\frac{1}{4}$ inch.



No. 163—Brass Top

Washing Machine Drain

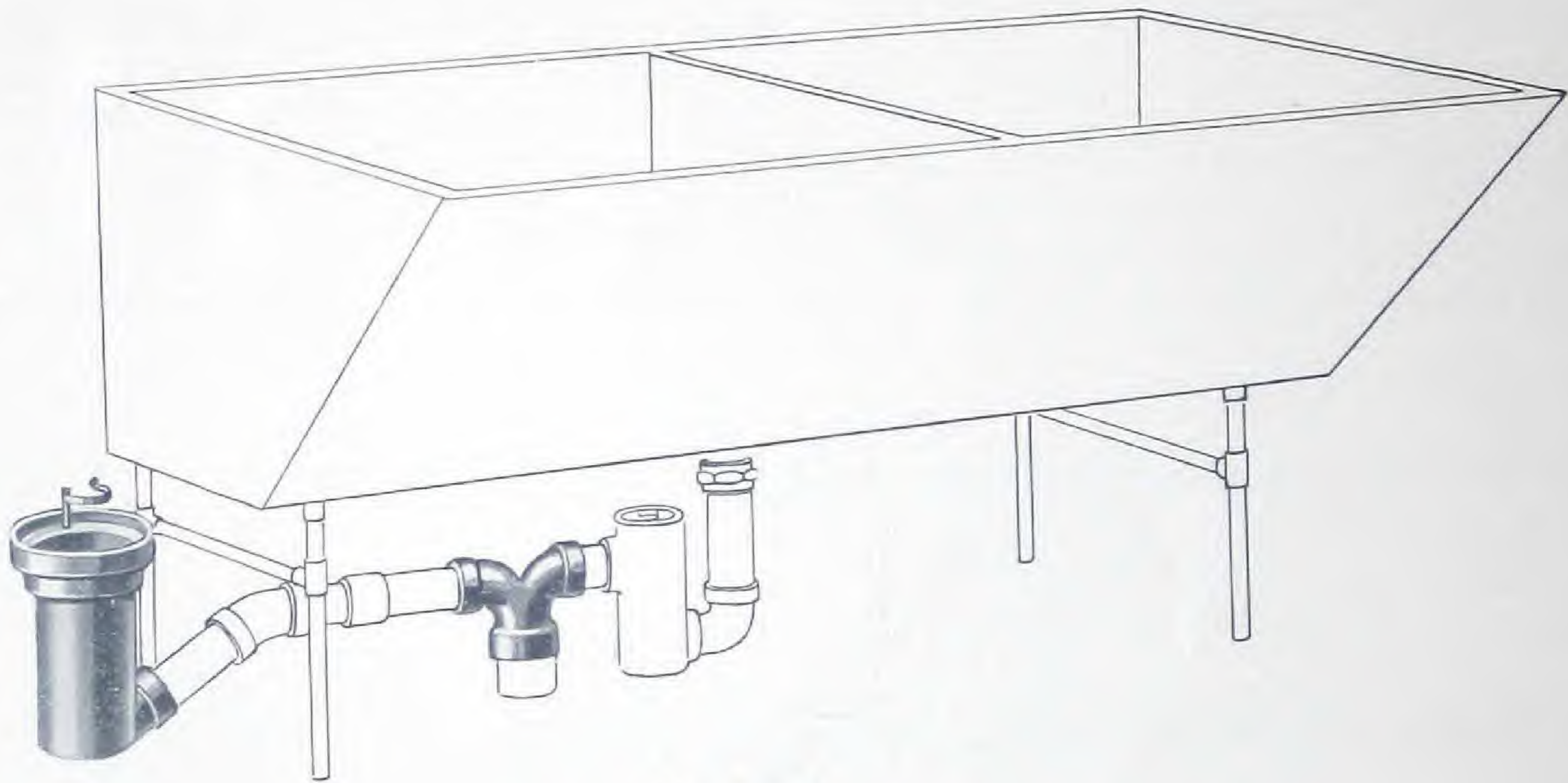

No. 105-B

Where floor drains have been omitted or inconveniently placed, the installation of washing machine drain above the floor is positively a necessary convenience.

Closet Flange No. 500

Cast iron, slotted for bolt adjustment. Depth of hub $1\frac{1}{4}$ inches.

Made to slip either std. or X. H. soil pipe.



No. 500

Closet Flange No. 502

Cast iron, slotted for bolt adjustment. Depth of hub 2 inches.

Made to slip either 3 or 4-inch std. or X. H. soil pipe.



No. 502

Closet Flange No. 503

Cast iron. Made specially for large building construction. Notched opening for closet bolts. Depth of hub $3\frac{1}{2}$ inches.

Made to slip over 4-inch wrought iron pipe.



No. 503

Closet Flange No. 504

Cast iron or brass. Tapped 4-inch iron pipe thread.



No. 504



Closet Bend No. 435-A

Cast iron closet bend.
 Long inlet for slip flange.
 With this bend you can do away entirely with test plugs.
 Inlet tapped for iron plug.
 Length of bend 16 inches. Made from real iron, full weight and easily cut off. Tapped 1½ or 2 inches.



Closet Bend No. 401

Cast iron closet bend X. H.
 Hub inlet slips 4-inch X. H. pipe. Openings tapped above flow of water through bend.
 Height 5½ inches. Tapped 1½ or 2 inches.
 Made in two lengths, 14 and 18-inch.

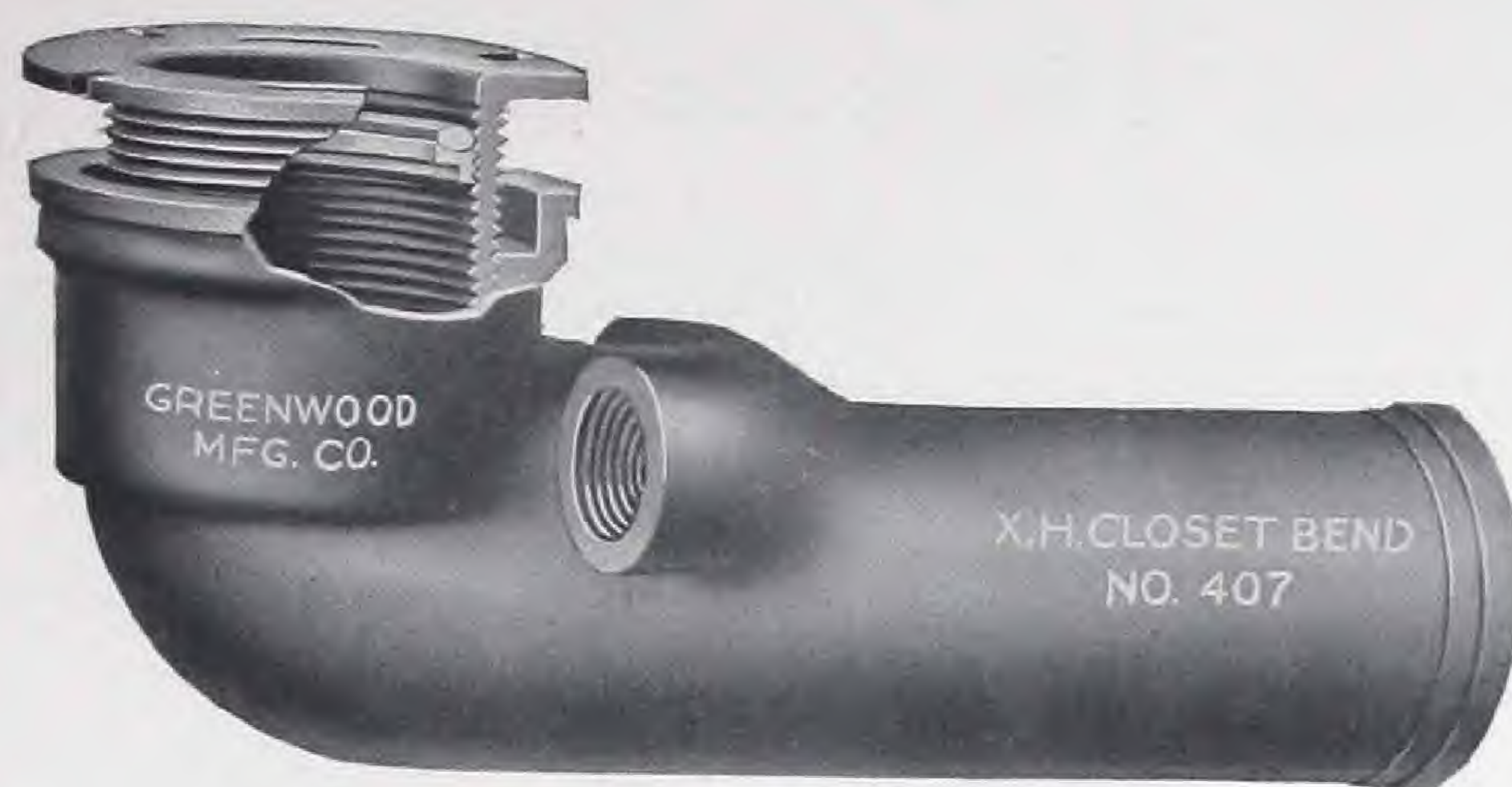

Seal Tight Closet Bend No. 407

This combination eliminates the unsanitary putty joint. The connection between bowl and flange is made gas tight with a special gasket compressed against the end of horn of bowl. This connection is easily made and adjusted to fit long or short horned bowls and will hold positively and permanently gas tight under several pounds pressure.

The flange has a 2-inch adjustment for floor line and the rough test can be made by screwing a 4-inch iron plug into hub of bend. Compare this construction in workmanship and total cost with a lead bend, brass ferrule, closet flange, wiping metal, plumber's time and putty joint.

This bend not only makes a much better job, but it requires less time to install and should it ever be necessary to remove the closet bowl on account of stoppage, it can be done without danger of breaking the bowl.

Closet Bend No. 405

Cast iron. X. H. closet bend for Durham work. Branch openings tapped 1½ or 2 inches. Bend tapped 4-inch inlet and outlet.



No. 405

Seal Tight Closet Flange No. 508

Cast iron seal tight closet flange for Durham work. Tapped 4-inch.



No. 508

Buildings of Brick and Mill Construction

The drawing shows the waste and vent connections to one of the numerous 4-inch wrought iron stacks in a building of 200 apartments. To each stack is connected 16 water closets, 16 basins and 16 tubs, featuring the Greenwood Mfg. Co.'s special drainage fittings. Vented stack crosses with hub inlets.

Cast iron closet bends.

Centrifugal bath traps.

Extra heavy slip couplings for tying in vent connections.

This installation complies with all basic laws pertaining to sanitary construction, requires fewer fittings, less pipe, the minimum in erection costs and is—accessible. This means a smaller investment and lower up-keep costs.

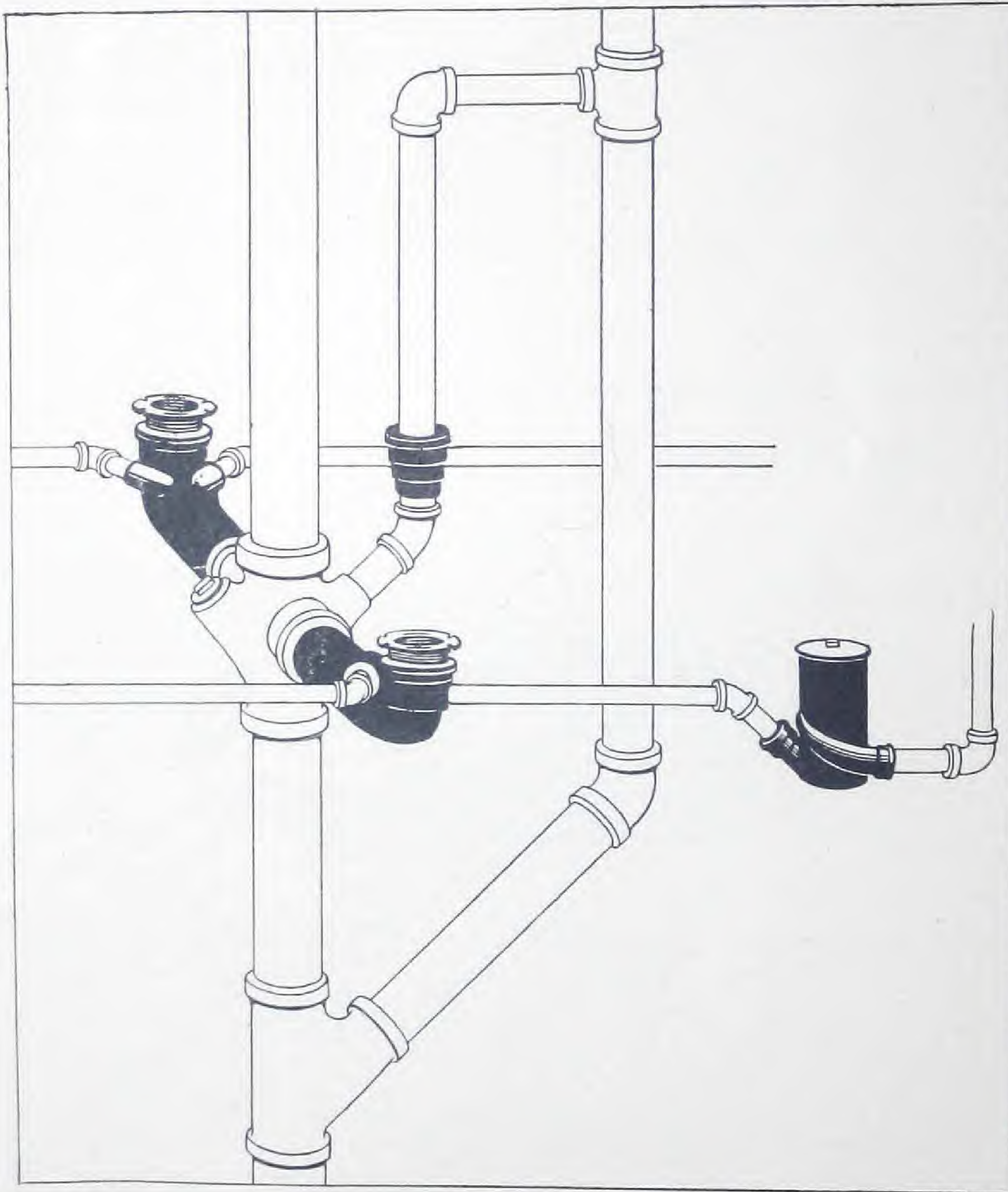

Use Greenwood Mfg. Co.'s drainage specialties on all large construction work. Connections can be made to comply with any code.

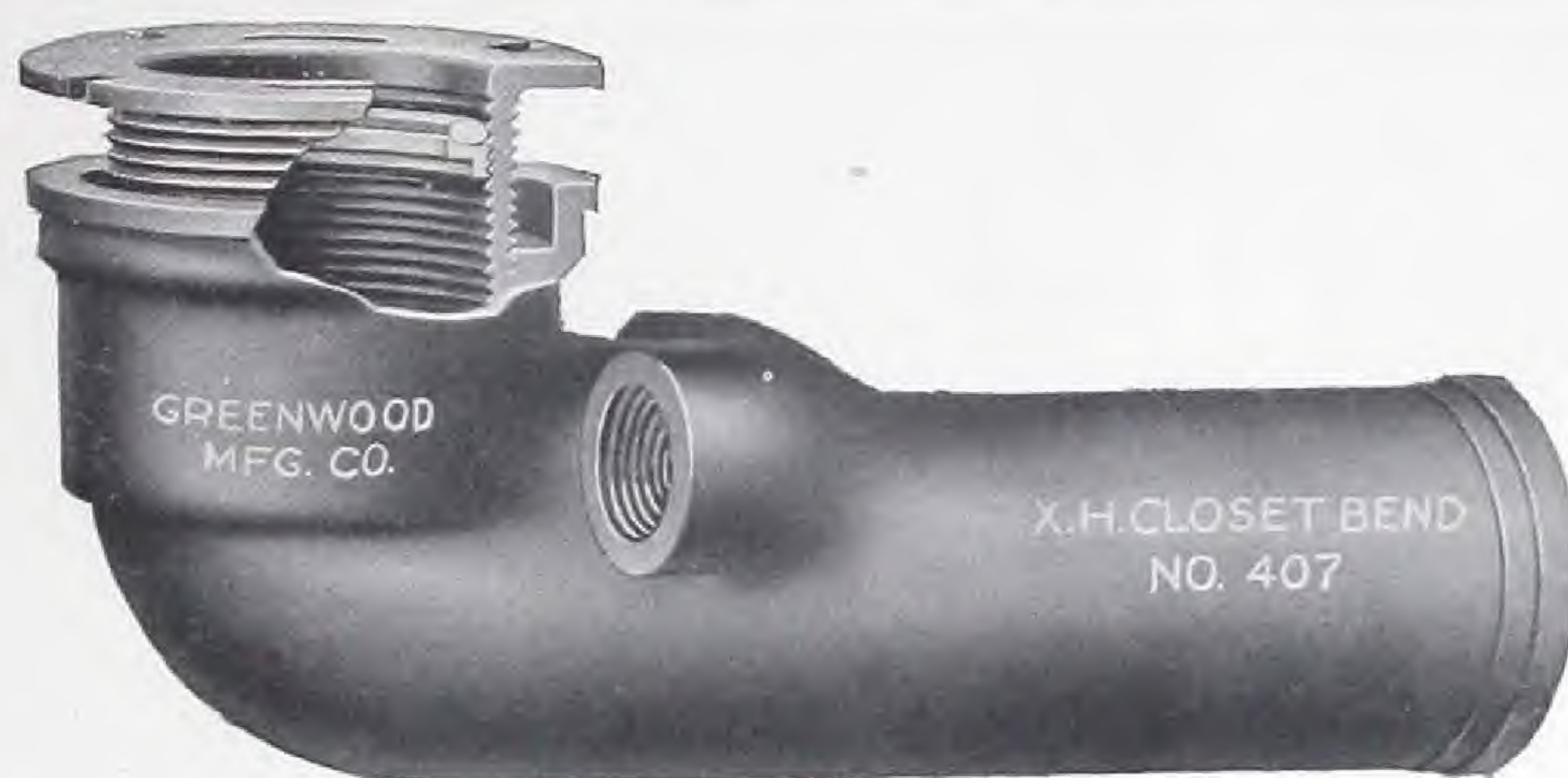
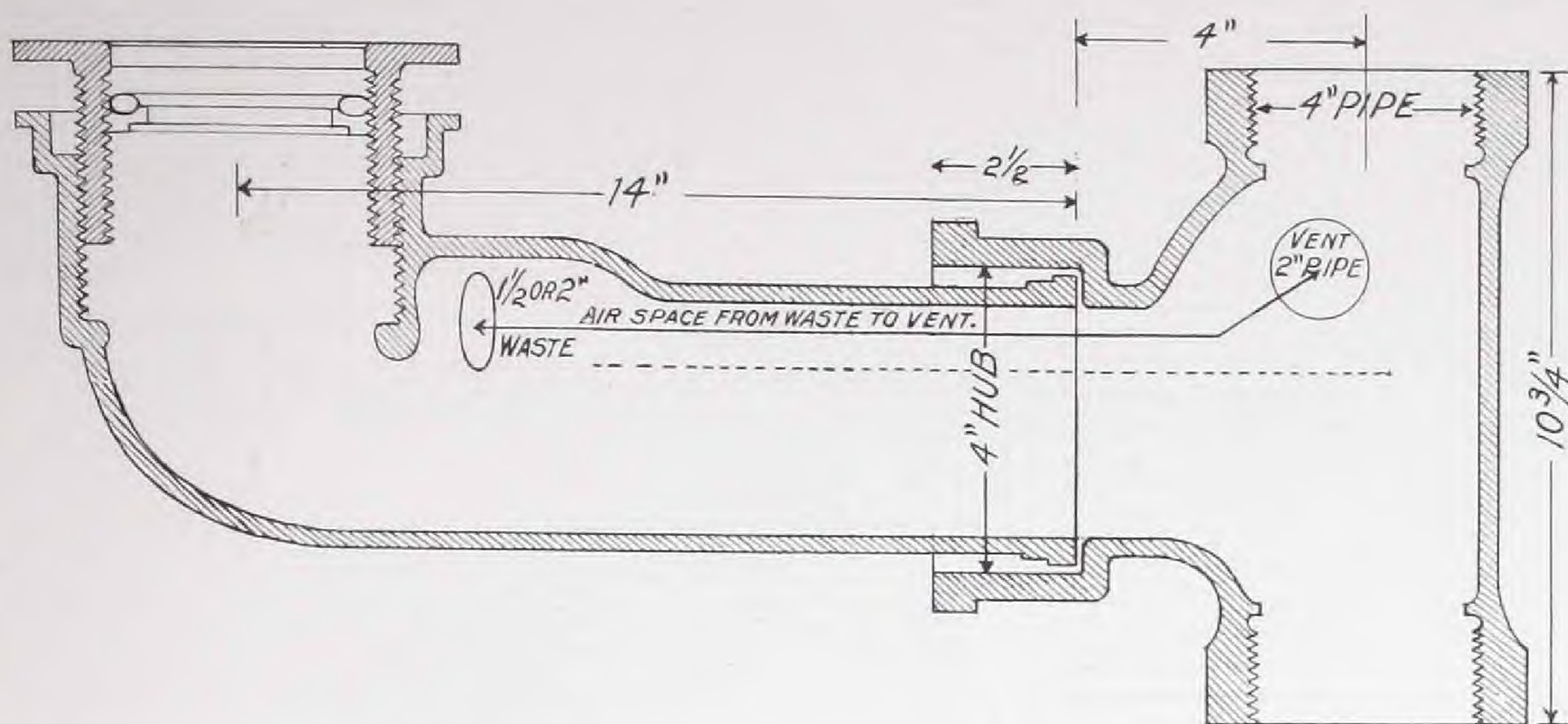

Seal Tight Closet Bend No. 407

Cast iron X. H. closet bend with adjustable closet flange, Y branch waste openings and seal tight connection for closet bowl.



Vent Tee No. 720-B

Combination X. H. vent tee. Cast iron, tapped 4x4 inches with 4-inch hub. Vent openings on each side tapped 2-inch on an angle of 45 degrees.



Vent Cross No. 725-B

Combination X. H. vent cross. Cast iron, tapped 4x4 inches with 4-inch hubs. Vent openings on each side tapped 2-inch on an angle of 45 degrees.

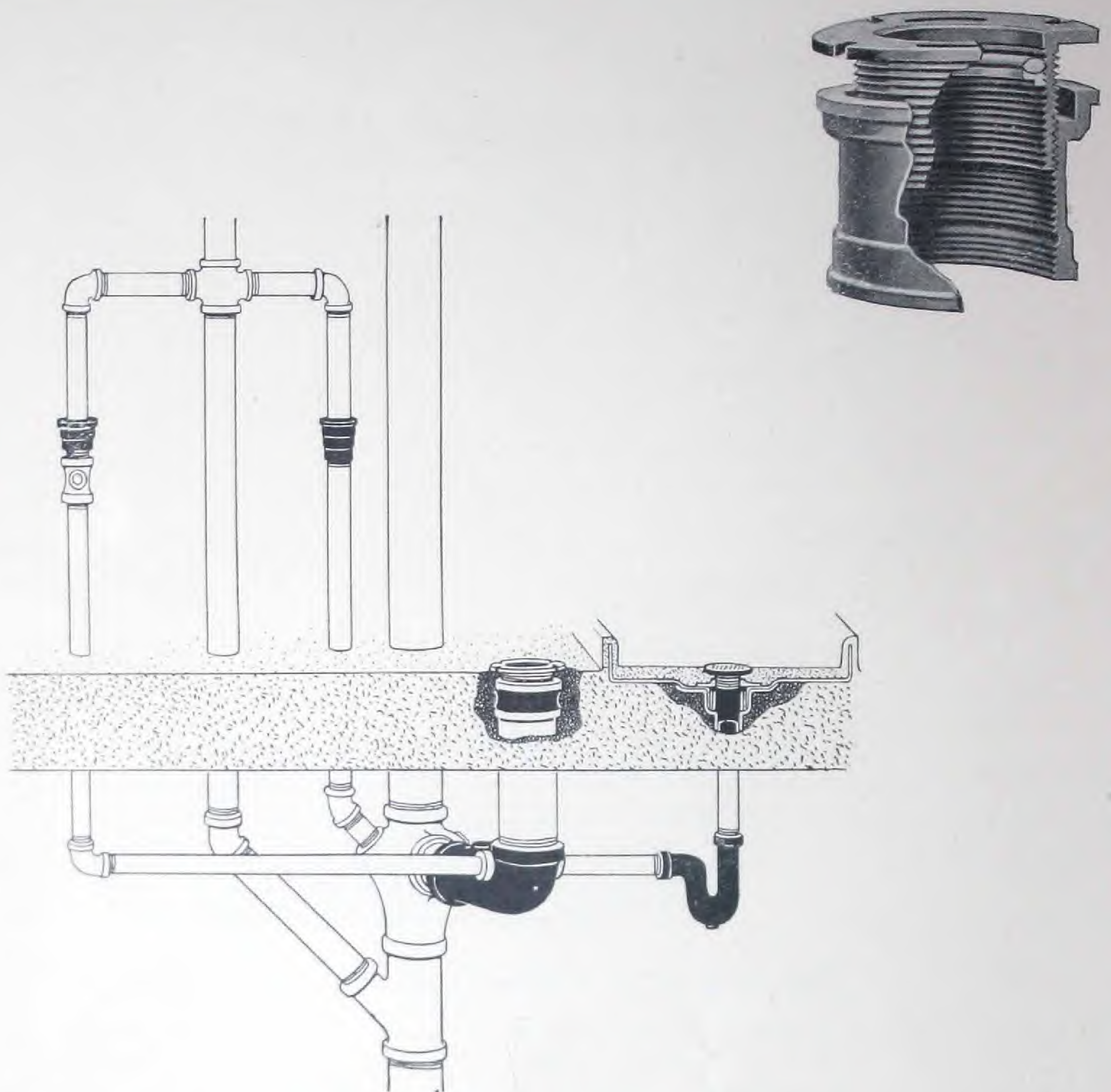

Buildings of Cement Construction

An all-Durham, wrought iron drainage system featuring the Greenwood Mfg. Co.'s vented closet tee, Durham closet bend, seal tight adjustable closet flange, seepage shower drain head with lead pan connection and X. H. slip couplings for tying in vents.

The 2-inch revent from closet tee vents the closet and shower trap, the basin waste being more than six feet in length is separately vented to comply with the building code, although some codes allow eight feet of waste without reventing the fixture when the waste connects to the closet bend above the flow of water through bend and the bend is revented from the closet tee or cross.

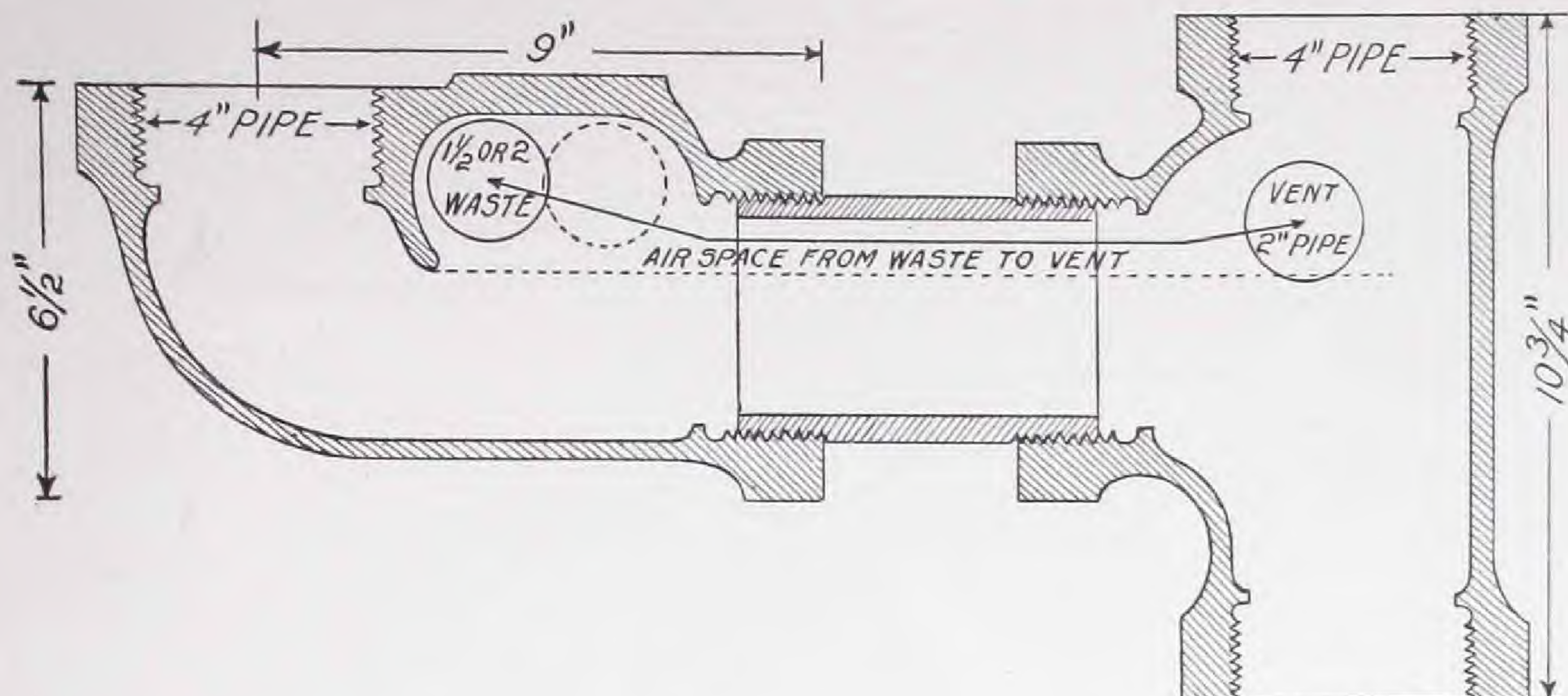

Closet Bend No. 405

Durham X. H. closet bend. Cast iron, tapped 4-inch with 1 1/2 or 2-inch waste connections, one on each side. This fitting may also be tapped 2 inches on top for vent.



No. 405

Vent Tee No. 705-B

Durham X. H. vent tee. Cast iron, tapped 4x4x4 inches. Vent openings on each side tapped 2 inches on an angle of 45 degrees.



No. 705-B

Vent Cross No. 715-B

Durham X. H. vented cross. Cast iron, tapped 4x4x4x4 inches. Vent openings on each side tapped 2 inches on an angle of 45 degrees.



No. 715-B



No. 804-A

Cleanout No. 804-A

Cast iron. Length $3\frac{1}{2}$, 8 and 12 inches, tapped with std. iron pipe thread and furnished with countersunk brass plug.

Made in 3 sizes: 2, 3 and 4-inch.



No. 804-B

Cleanout No. 804-B

Cast iron. Length $3\frac{1}{2}$, 8 and 12 inches, tapped with std. iron pipe thread. Brass plug tapped for $\frac{1}{4}$ -inch extension brass bolt and furnished with brass ring and plate N. P.

Made in 3 sizes: 2, 3 and 4-inch.



No. 806

Cleanout No. 806

Cast iron with thread cast to body. For testing or for openings left for future connections, calk in and screw out.

Made in 4-inch only.



No. 805

Cleanout No. 805

Used for inspection and cleanout for tile drains. Cast iron body with 6-inch flanged base ribbed to hold tight in cement.

Furnished with raised head or countersunk brass plug. Size 4-inch.



No. 804-A

No. 807

No. 804-B

Cleanout No. 804-A

Cast iron. Tapped std. pipe thread and fitted with countersunk brass plug machined to screw down flush with iron body when test tight.

Sizes 3 or 4-inch.

Length, 3½, 8 or 12 inches.

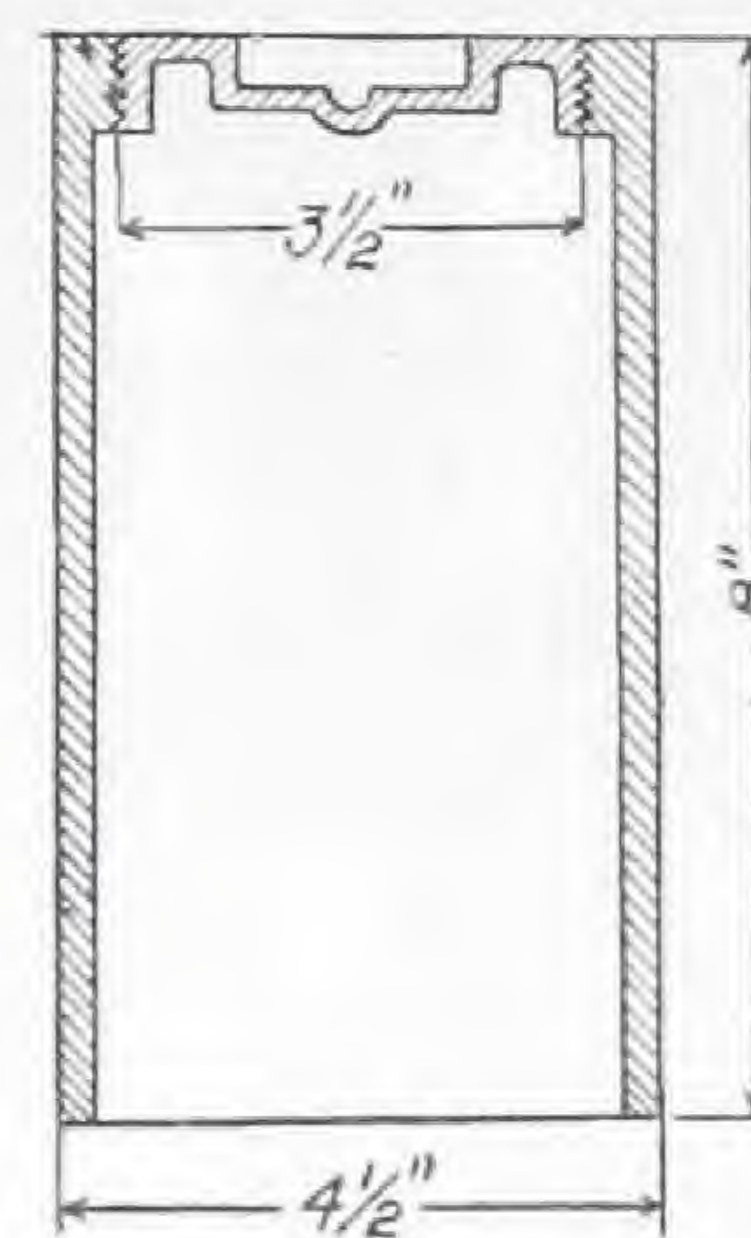

Cleanout No. 804-B

Cast iron. Tapped std. pipe thread and fitted with countersunk brass plug, N. P. brass ring and cover.

Sizes 3 or 4-inch.

Length, 3½, 8 or 12 inches.

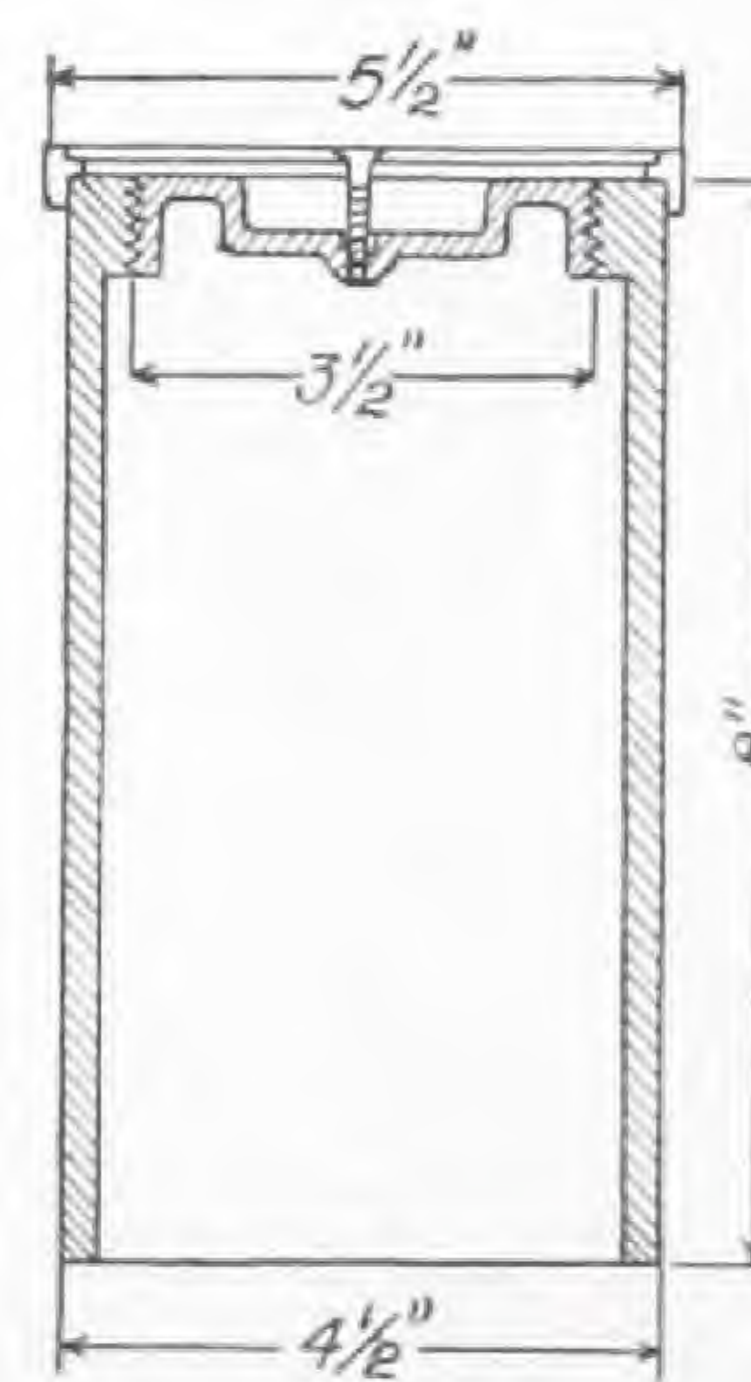

Cleanout No. 807

Cast iron. Encased heavy traffic cleanout. Length 8 inches. Slip cover 2½ inches deep protects the brass cleanout plug.

Sizes 3 or 4-inch.

We recommend this cleanout for driveways, garages and factories.

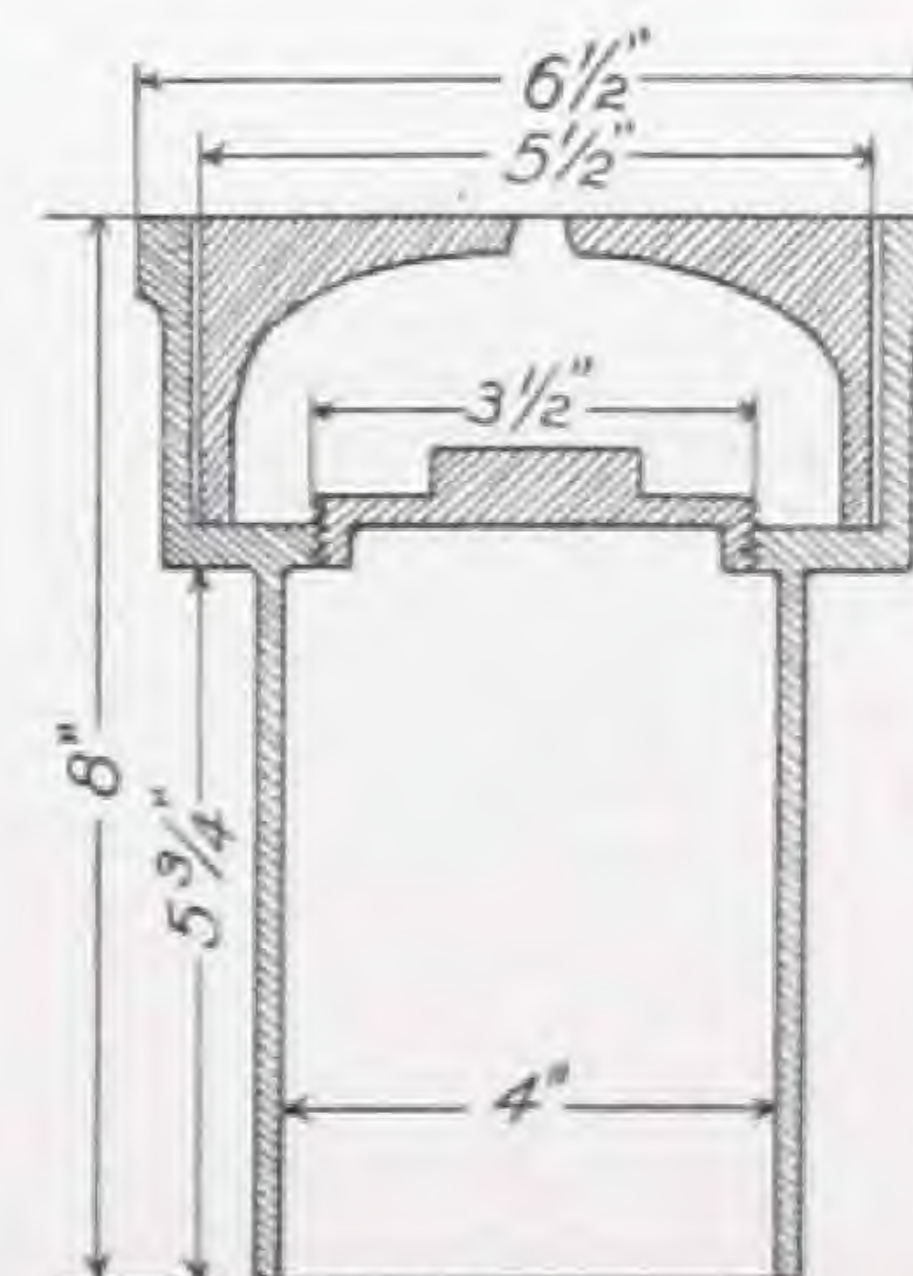



No. 835

Wall Vent Cap No. 835

Cast iron or brass. Fits tight to wall, making a finished appearance, and is held securely in place with expander. Made in 4-inch only.



No. 565

Twin Elbow No. 565

Cast iron. 1½-inch inlets and 2-inch outlet, width 5¼ inches, length 4 inches. The dividing line of flow is carried down below waste inlets and prevents one fixture syphoning the other.



No. 555

Slip Coupling Male, X. H. No. 555

Cast iron. A combination of screwed thread and calked joint which takes the place of ground joint union, long thread and lock nut, or R. and L. coupling.

Made in two sizes, 1½ or 2-inch.



No. 556

Slip Coupling Female, X. H. No. 556

Cast iron. A combination of screwed thread and calked joint which takes the place of ground joint union, long thread and lock nut, or R. and L. coupling.

Made in 4 sizes: 1½, 2, 3 and 4-inch.

Roof Sump No. 140

A permanent connection is easily made between roof and rain water leaders with the Greenwood Mfg. Co.'s cast iron roof sump.

It is an efficient non-freezing rain conductor roof connection and made for all classes of buildings and various types of roof construction.

Where felt roofing is used no lead or copper flashings are necessary. The roofing felts are joined to drain by a V-shaped ring drawn to place with brass bolts and permanently holding the felts tightly against the inside of sump receptacle. This construction permits a continuous roof surface, secured direct to sump inlet.

The outer strainer or guard having inlet openings of more than twice the outlet area is an important feature in roof sump construction. It also guards against foreign substances entering the drain and prevents gravel from washing into and blocking sewer.

This sump may be connected with either lead, cast or wrought iron conductors and is made in 4 sizes to fit 3, 4, 5 or 6-inch conductors.



No. 140
(See Page 47)

Roof Flange No. 145

A permanent cast iron connection between soil pipe stack and roof. The roofing is joined to flange by a V-shaped ring drawn to place with brass bolts which secures the felts permanently to roof flange. The flange being secured to stack with a calked joint makes this connection absolutely water tight on flat roofs. Sizes 3, 4, 5 and 6-inch.



No. 145



No. 240

Cover No. 240

Cast iron drain covers for crock hubs. The legs elevate cover flush with top of crock hub.
Made in 9 sizes.

- No. 240, Diameter 5½", fits inside 4" crock hub.
- No. 240, Diameter 8", fits inside 6" crock hub.
- No. 240, Diameter 10", fits inside 8" crock hub.
- No. 240, Diameter 12½", fits inside 10" crock hub.
- No. 240, Diameter 15", fits inside 12" crock hub.
- No. 240, Diameter 21½", fits inside 18" crock hub.
- No. 240, Diameter 24½", fits inside 20" crock hub.
- No. 240, Diameter 28", fits inside 24" crock hub.
- No. 240, Diameter 29½", fits inside X. H. 24" crock hub.



No. 250

Cover No. 250

Cast iron bar strainer fits inside of 3, 4 and 6-inch soil pipe hub.



No. 200

Cover and Frame No. 200

Cast iron covers and frames for valve, cleanout, meter pits, etc.
Made in 5 sizes.

Diameter of Ring	Diameter of Cover
10 inches	8½ inches
12 inches	10½ inches
14 inches	12½ inches
20 inches	18½ inches
25 inches	23½ inches



No. 273

Cover and Frame No. 273

Cast iron meter pit cover and frame.
Size of cover 17x24 inches.
Size of frame 23x28 inches.

Cover and Ring No. 615

Cast iron ring and cover for meter boxes, valve pits, tunnels, etc.
Diameter of ring 46 inches.
Diameter of cover 36 inches.
Thickness of ring 2 inches.



No. 615

Strainer and Ring No. 615-A

Cast iron ring and strainer to fit over hub of 30 or 36-inch crock sumps.
Diameter of ring 46 inches.
Diameter of strainer 36 inches.
Thickness of ring 2 inches.



No. 615-A

Cover and Ring No. 615-B

Cast iron, seal tight ring and cover for sewer manholes, acid or oil sump pits.
Diameter of ring 46 inches.
Diameter of cover 36 inches.
Thickness of ring 2 inches.

To properly set cover, the outer ring should be imbedded in soft cement. Note the bevel on outer edge. It anchors the ring securely in the cement, preventing it from working loose.



No. 615-B

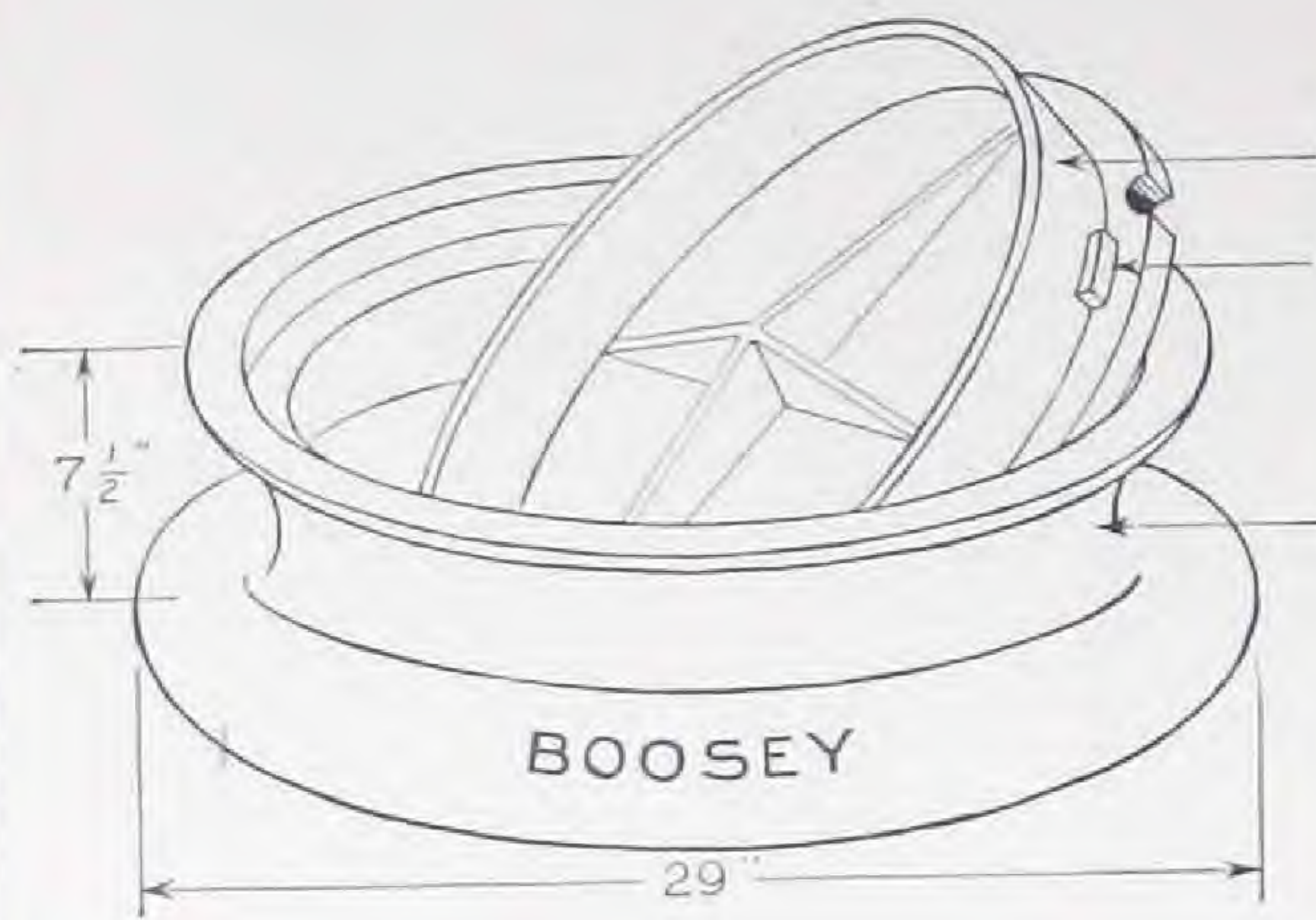

Heavy Traffic Road Manhole Covers

Deep flange prevents cover tipping.

Diameter of cover 22 inches.

Diameter of ring top 24 inches.

Diameter of ring base 29 inches.

Height over all 7 1/2 inches.

Approximate carrying weight 20 tons.

The concave shape of ring anchors the base securely in the cement, making the cover self-supporting and protects the sewer connections below.



No. 335-A

Manhole Cover No. 335-A

Cast iron heavy traffic manhole cover with self-supporting concave ring.

Carrying weight approximately 20 tons.



No. 335-B

Road Drain No. 335-B

Cast iron heavy traffic road drain with self-supporting concave ring.

Carrying weight approximately 20 tons.



No. 335-E

Road Drain No. 335-E

Cast iron heavy traffic road drain. We recommend this design of cover for garags sumps.

Carrying weight approximately 20 tons.

Light Manhole and Drain Cover

For lawns, playgrounds and sumps.
 Diameter of cover 22 inches.
 Diameter of ring top 24 inches.
 Diameter of ring base 29 inches.
 Height over all 4½ inches.

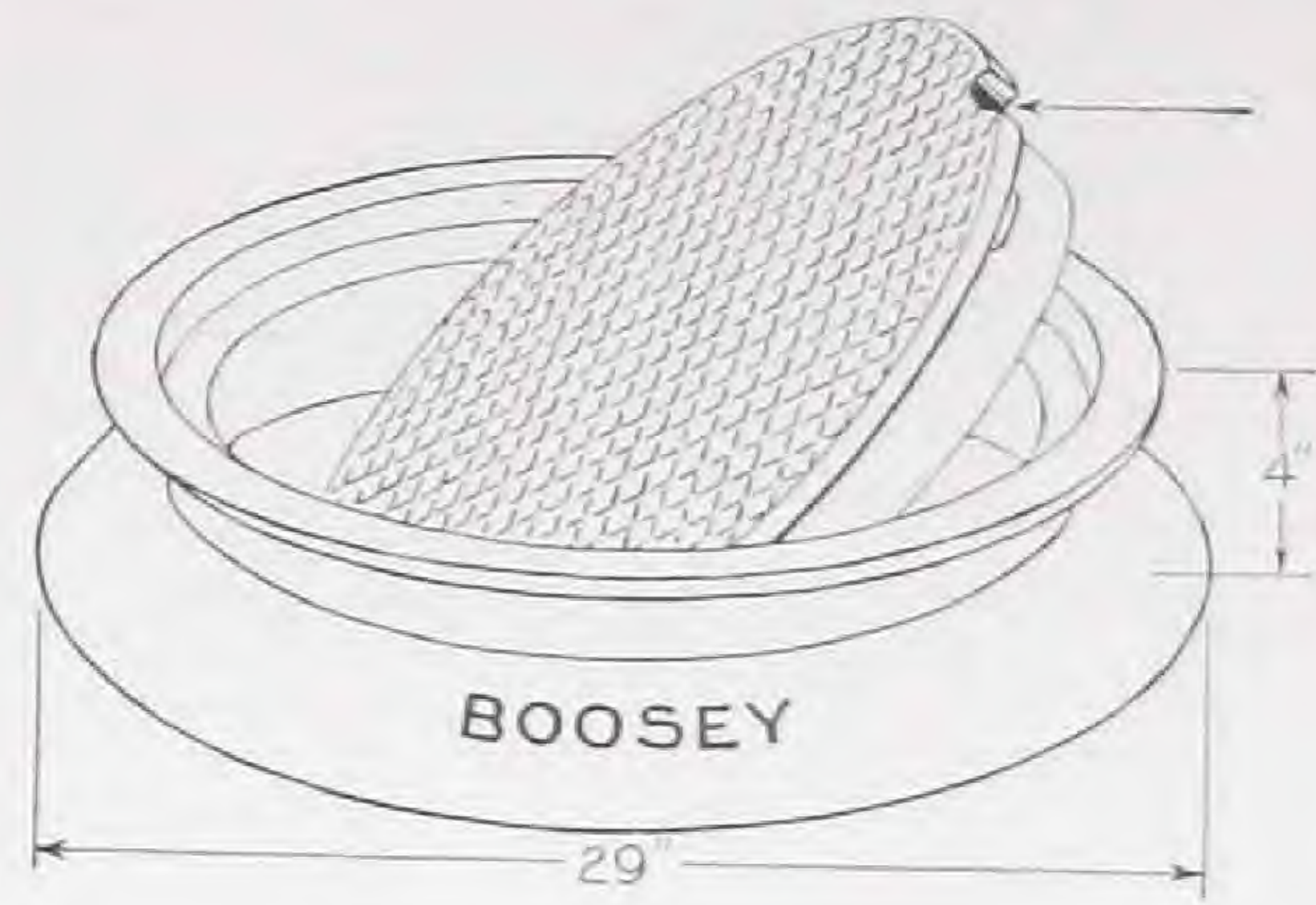

Manhole Cover No. 336-A

Cast iron anti-slip cover and self-supporting concave ring.
 Carrying weight approximately 10 tons.



Lawn Drain No. 336-H

Cast iron lawn drain with raised strainer and guard.



Drain Cover No. 336-E

Cast iron drain with interchangeable strainers made in three different weights, heavy, medium and light.

Carrying weight, 1-5 and 10 tons.



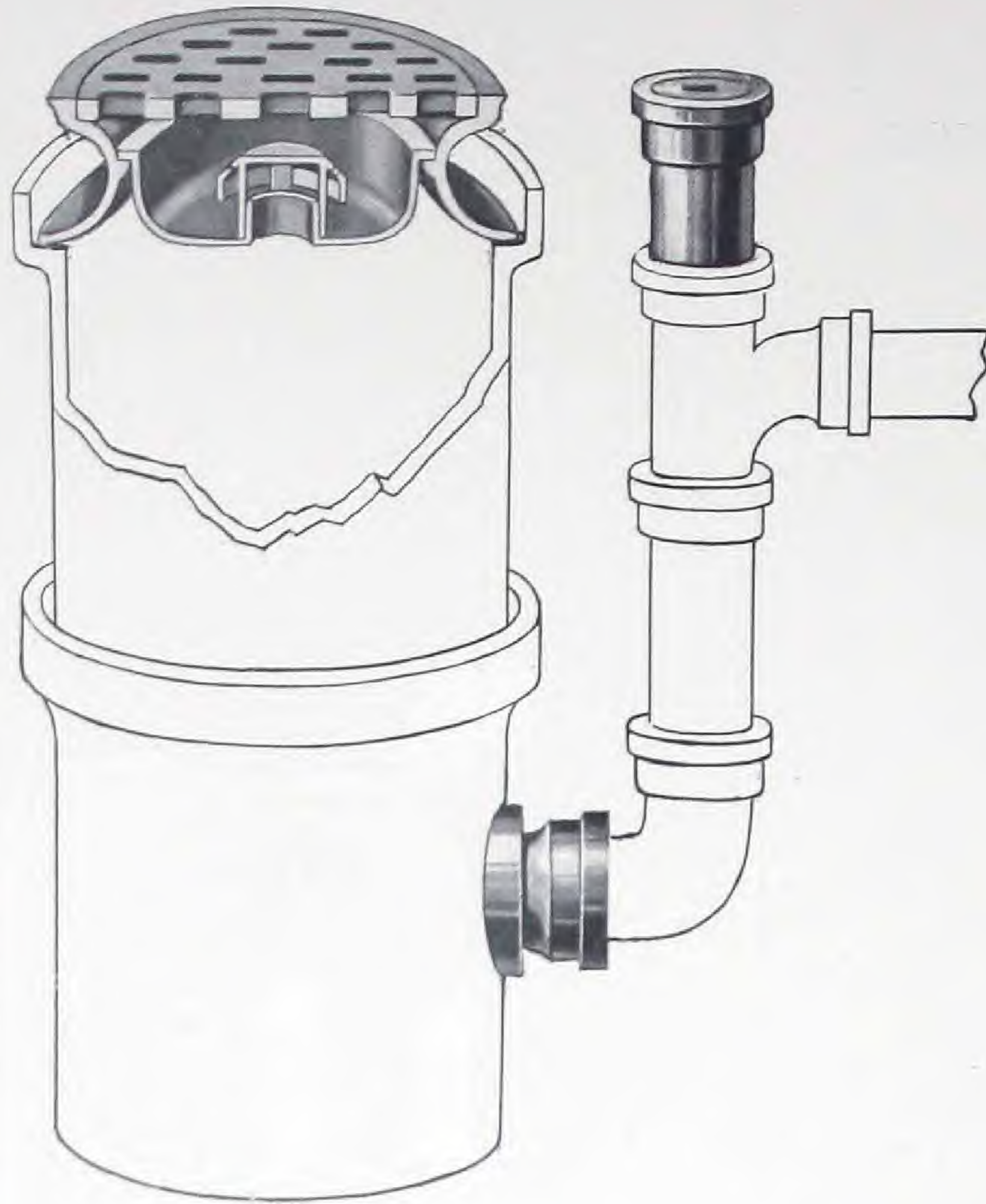

No. 335-F

Garage Sumps

The Greenwood Mfg. Co.'s sump has a 24-inch seal and when the occasion demands, holds for evaporation 47 gallons of gasoline, thereby giving all reasonable protection to public sewers. The sump body is constructed with two 24-inch glazed tile crocks, making economical construction.

Waste connection from sump is made with a 4-inch cast iron, water tight, flanged hub union. The drain cover, of same weight and carrying capacity as road manhole covers, has a removable catch basin that prevents mud and sand entering sump.

It is far easier and much cheaper to remove mud and sand from the catch basin in cover than to bail out sump and then dig the dirt out of the bottom.

Greenwood Mfg. Co.'s sumps are approved by public works, building and sanitary departments.



No. 390

Hub Union No. 390

Cast iron hub union used for making soil pipe waste connection to crock sump. The two flanges are filled with cement and are then drawn to place with lock nut. This makes a permanently tight joint to which the soil pipe may be calked.



No. 807

Cleanout No. 807

Cast iron cleanout. Will safely carry the same heavy traffic as road cover. The brass cleanout cover in base of hub is protected with heavy iron cover set into hub.

Sump Cover No. 335-F

Cast iron sump cover with removable catch basin; fits 24-inch crock.

Deep flange prevents cover tipping.

Diameter of cover 22 inches.

Diameter of ring top 24 inches.

Diameter of ring base 29 inches.

Height over all 7½ inches.

Approximate carrying weight 20 tons.

The concave shape of ring anchors the base securely in the cement, making the cover self-supporting and protects the sewer connections below.



No. 335-F

Auxiliary Drain No. 182

Cast iron auxiliary drain and sand trap.

Prevents mud and sand from wash rack entering sump or main sewer.

Easily cleaned and inspected.

Size 12x14 inches.

Carrying weight approximately 1 ton.



No. 182

Auxiliary Drain No. 160

Cast iron heavy traffic auxiliary drain to sump.

Diameter 12 inches.

Depth 3 inches.

Waste outlet 3 or 4-inch.

Carrying weight approximately 20 tons.



No. 160

Floor Drain No. 180

Cast iron floor drain with double strainer and bell trap.

Diameter of top 12x12 inches.

Depth 10 inches.

Carrying weight approximately 2 tons.



No. 180



No. 360

Factory Manhole Cover No. 360

Cast iron cover and ring.
 Diameter of ring 27 inches.
 Diameter of cover 20 inches.
 Thickness of cover 1 inch.
 Solid or perforated covers.
 Carrying weight approximately 10 tons.

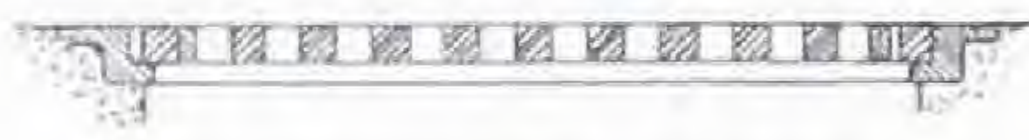

No. 375

Area Drain No. 375

Cast iron ring and grating.
 Diameter of ring 24 inches.
 Diameter of cover 21 inches.
 Thickness of cover 5/8-inch.
 Carrying weight approximately 1/2-ton.



No. 300

Light Garage Drain Covers

No.	Diam. of ring	Diam. of strainer	Load
300	17 inches	12 inches	1/2 ton
300A	22 inches	14 inches	3 tons
300B	28 inches	14 inches	3 tons
300C	34 inches	14 inches	3 tons
300D	34 inches	24 inches	3 tons



No. 604

Cleanout Frame and Covers

No.	Diam. of ring	Diam. of cover	Load
604	21 inches	16 inches	1/2 ton
604A	25 inches	19 inches	1 ton
604B	26 inches	21 inches	1 ton
604C	29 inches	24 inches	1 ton
604D	36 inches	30 inches	1 ton

Floor Drain No. 165

Cast iron deep drain head.
Easily changed into a deep seal bell trap or sand trap by screwing a 6-inch bell to cover and extending the 4-inch soil pipe up into it.
Diameter 12½ inches.
Depth 9 inches.
Waste outlet 4 inches.
Carrying weight approximately ½ ton.



No. 165

Floor Drain No. 170

Cast iron drain cover and trap used for auxiliary garage drain, elevator and machinery pits.
Diameter 14 inches.
Depth 6½ inches.
Waste outlet either 3 or 4-inch.
Carrying weight approximately 1 ton.



No. 170

Floor Drain No. 150

Cast iron shallow drain head and cover.
Diameter 14 inches.
Depth 4 inches.
Waste outlet either 3 or 4-inch.
Carrying weight approximately 1 ton.



No. 150

Trap No. 106

Size 4-inch.
Depth of seal 4-inch.
This trap may be used with any drain head having 4" hub outlet.



No. 106

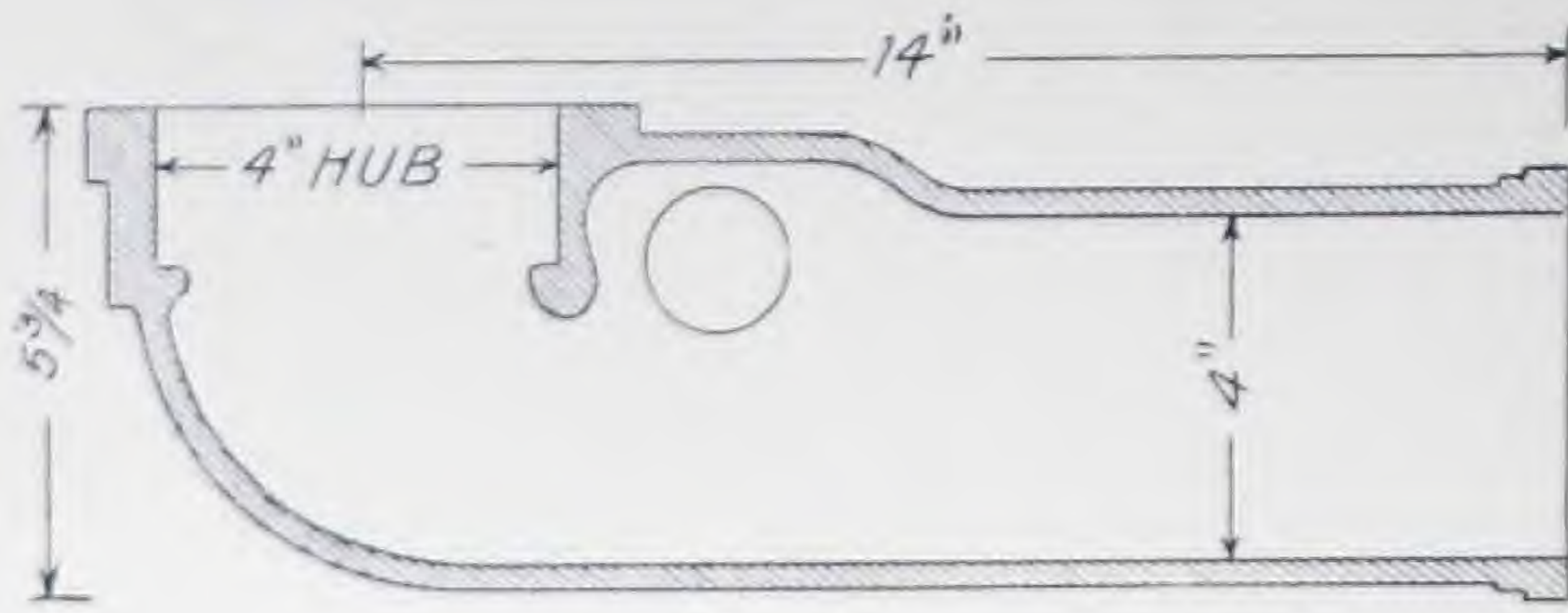

No. 401

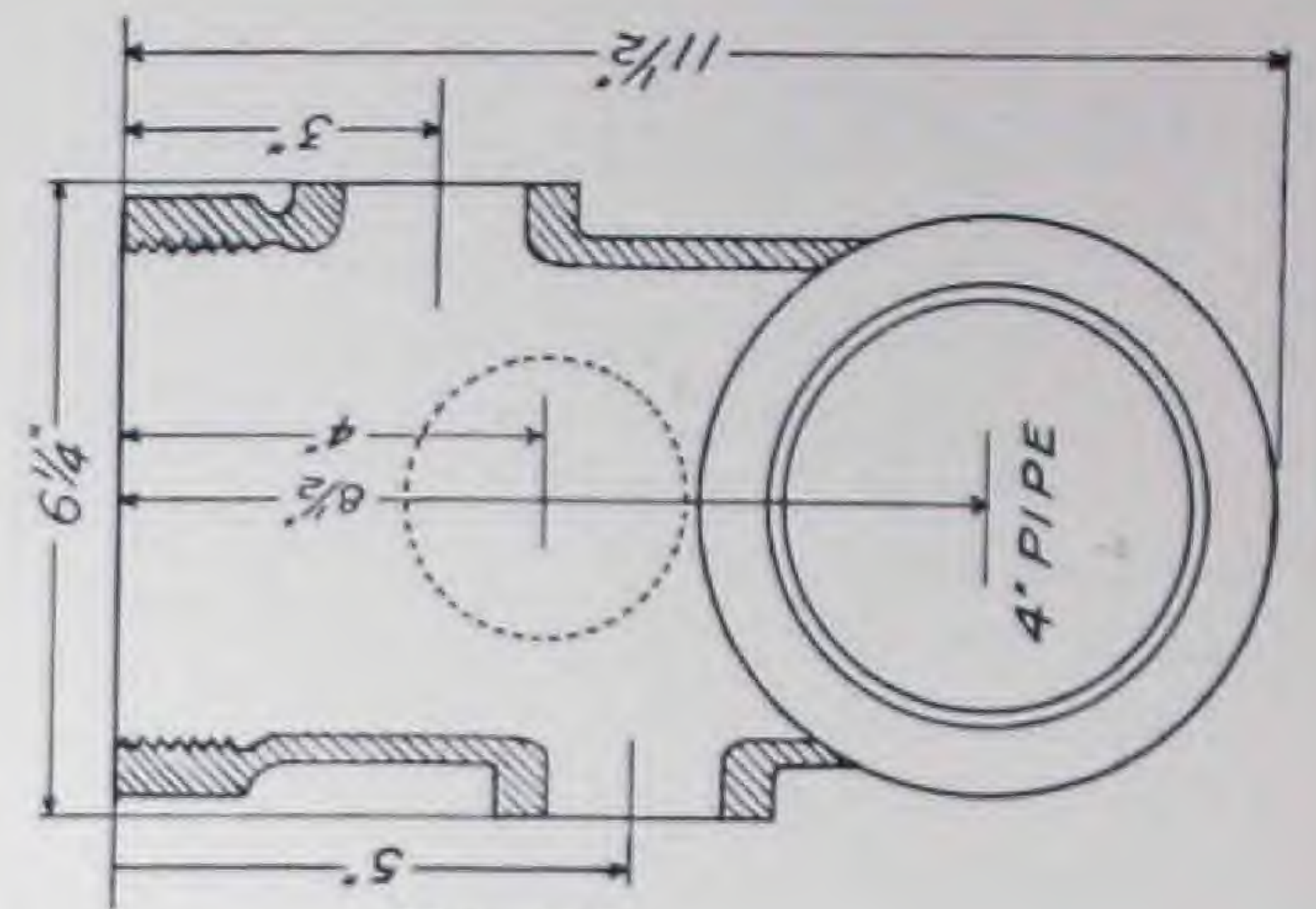

No. 405

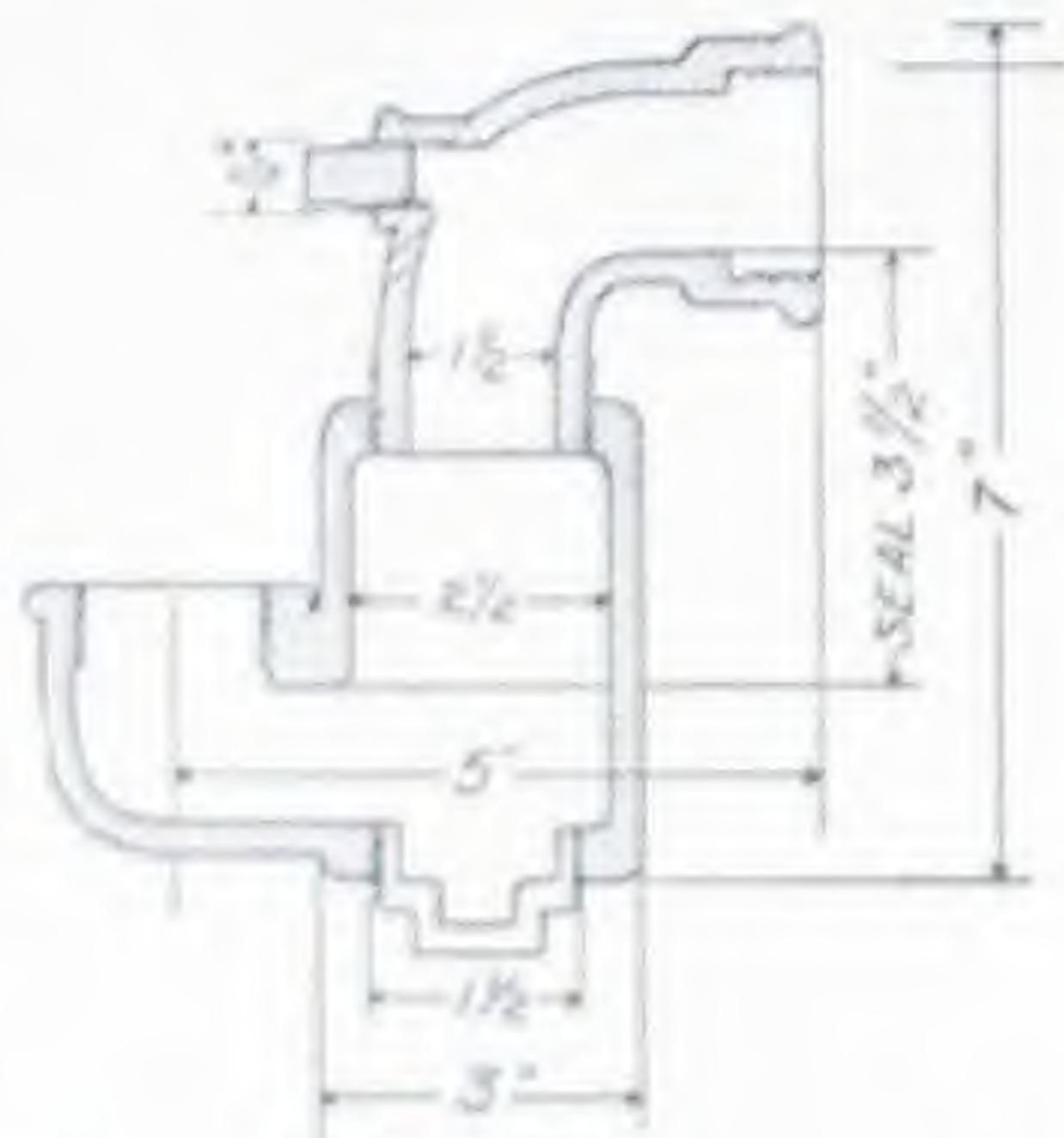

No. 60

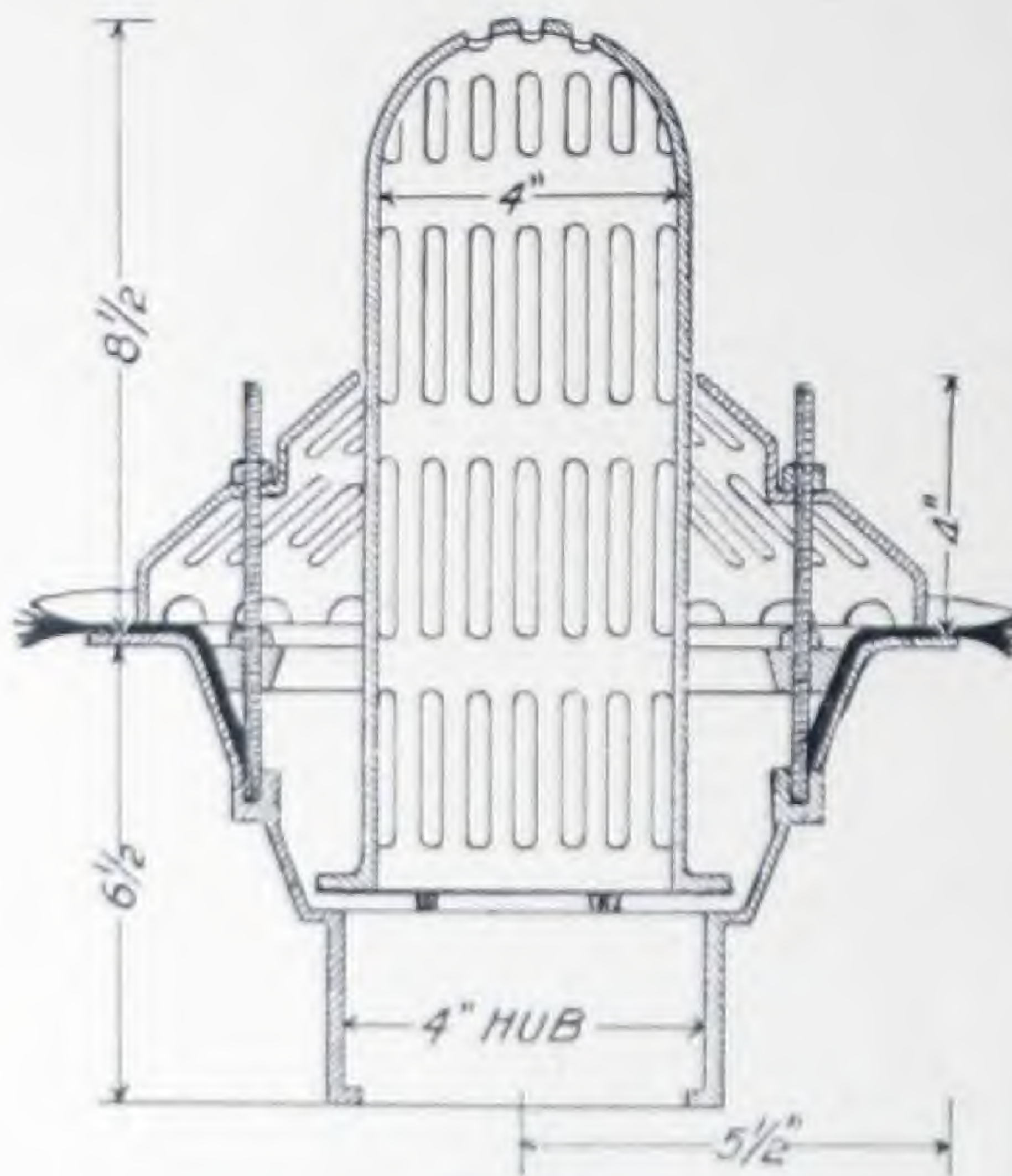

No. 140

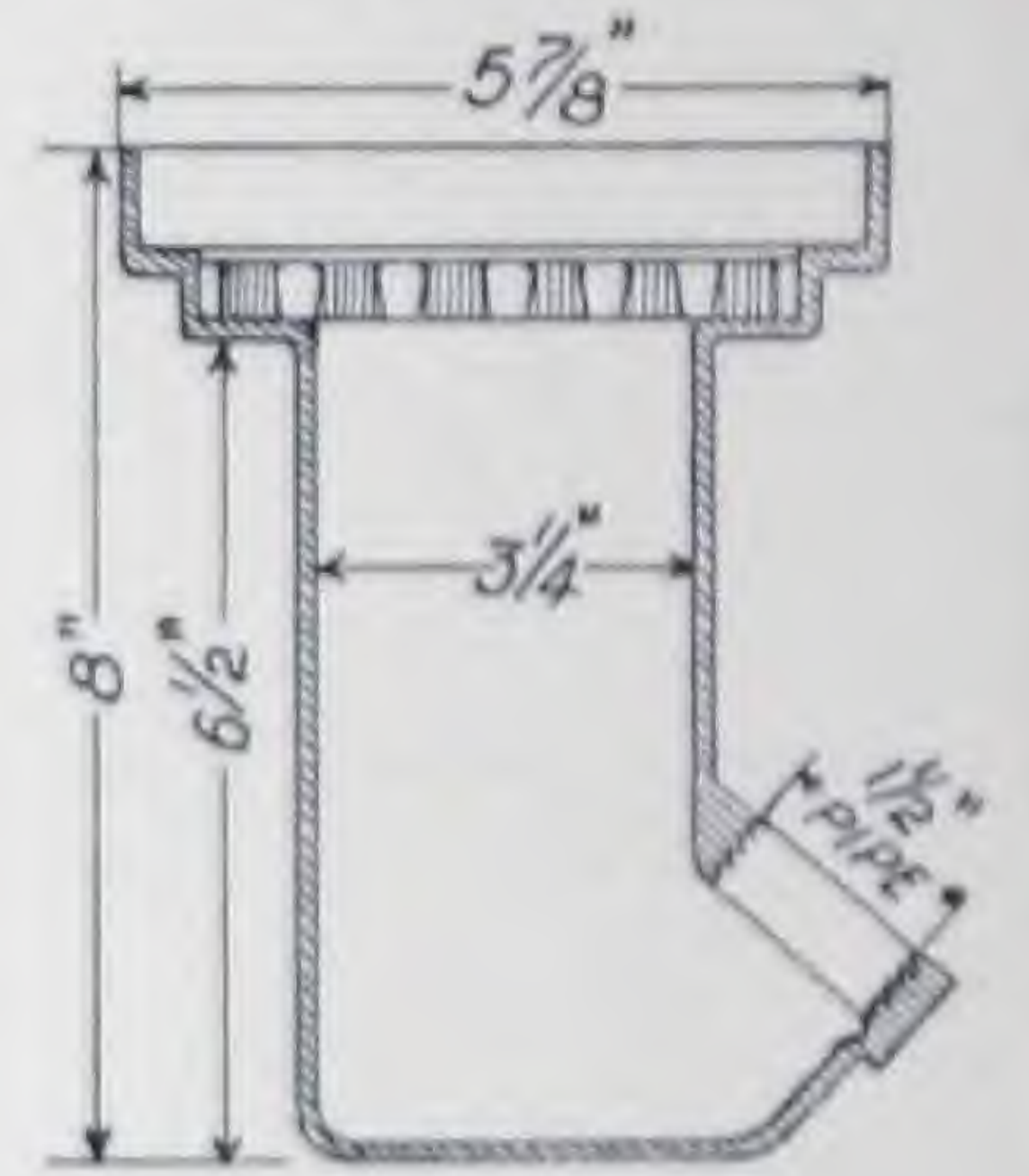

No. 105-A

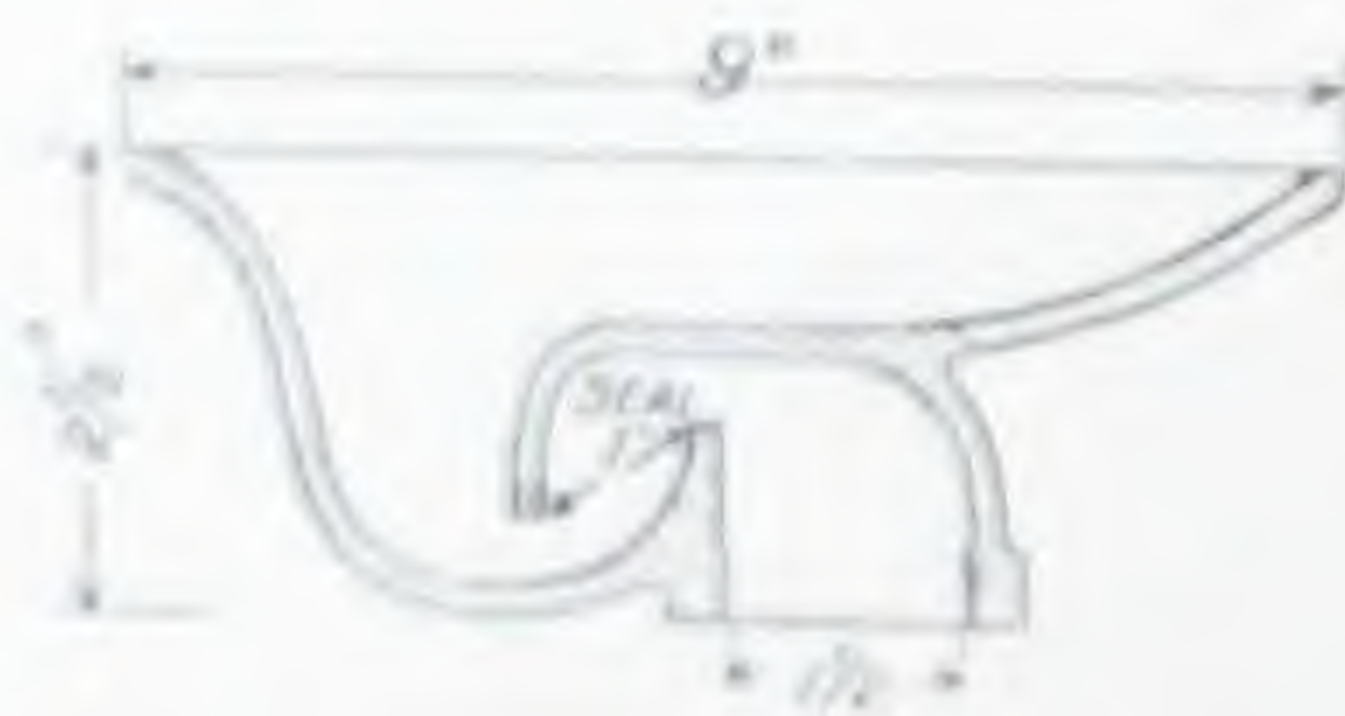

No. 175

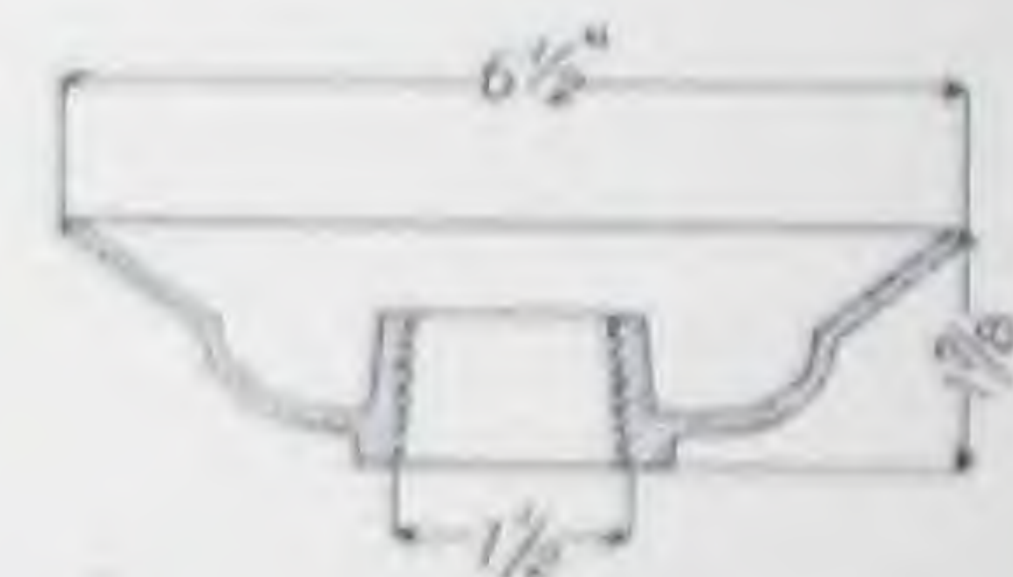

No. 178

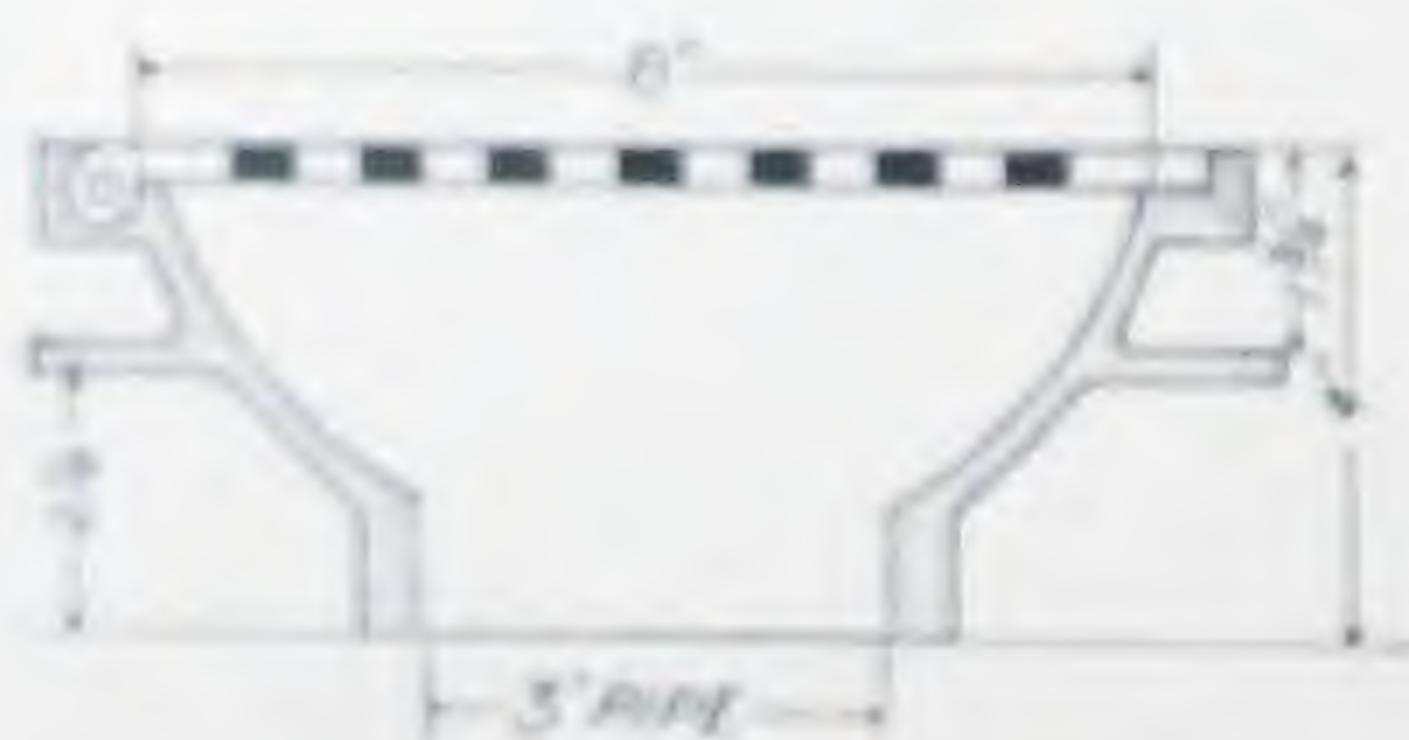

No. 96

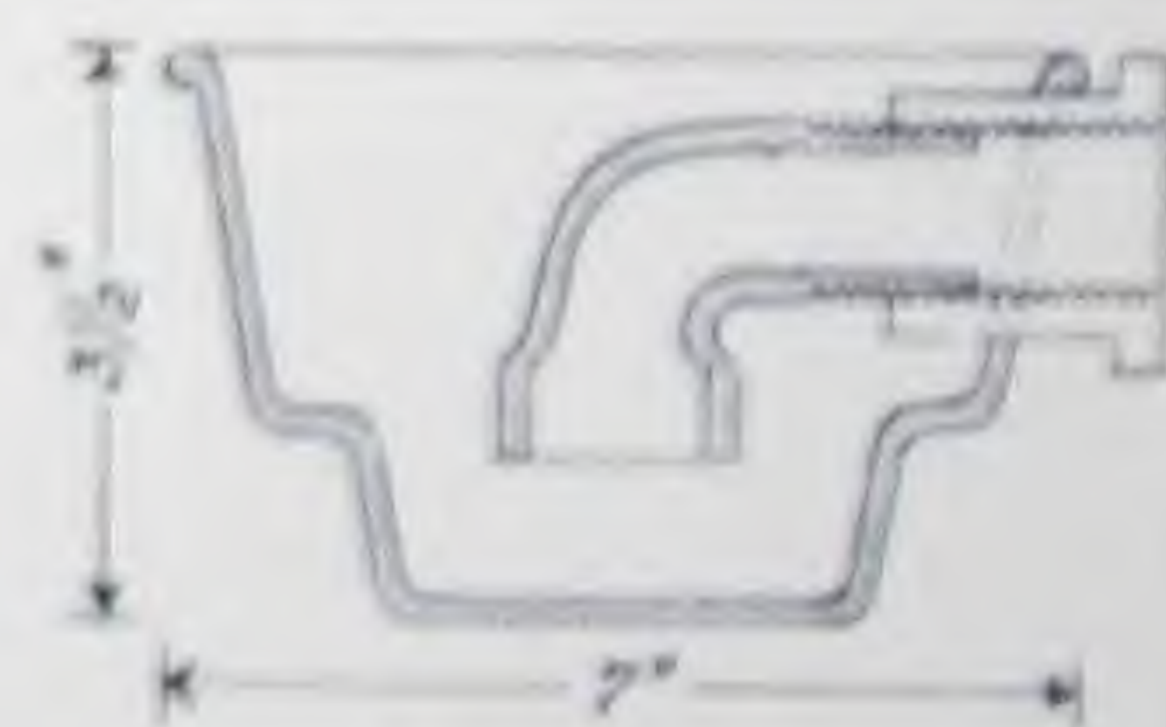

No. 175-B

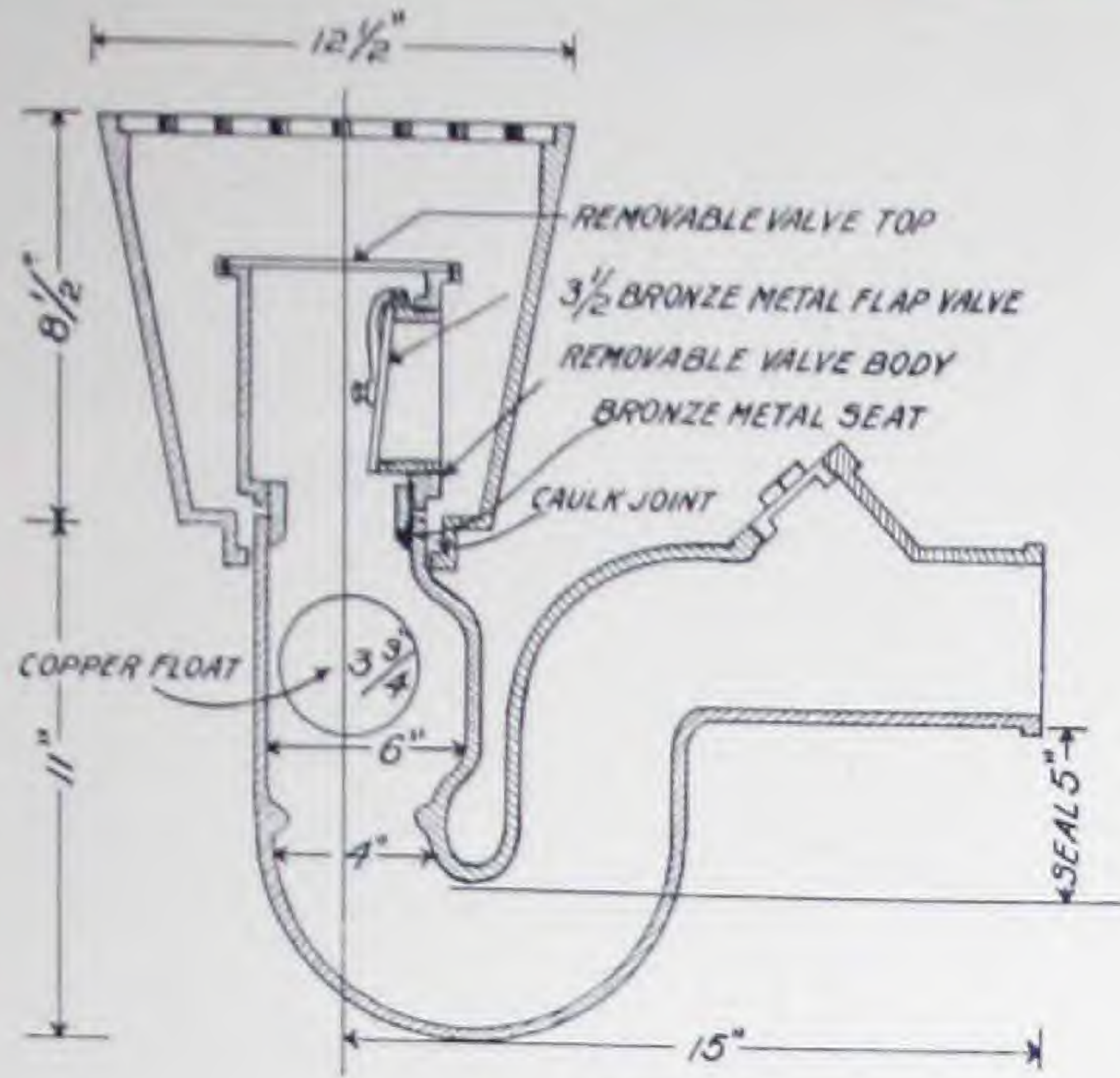

No. 111

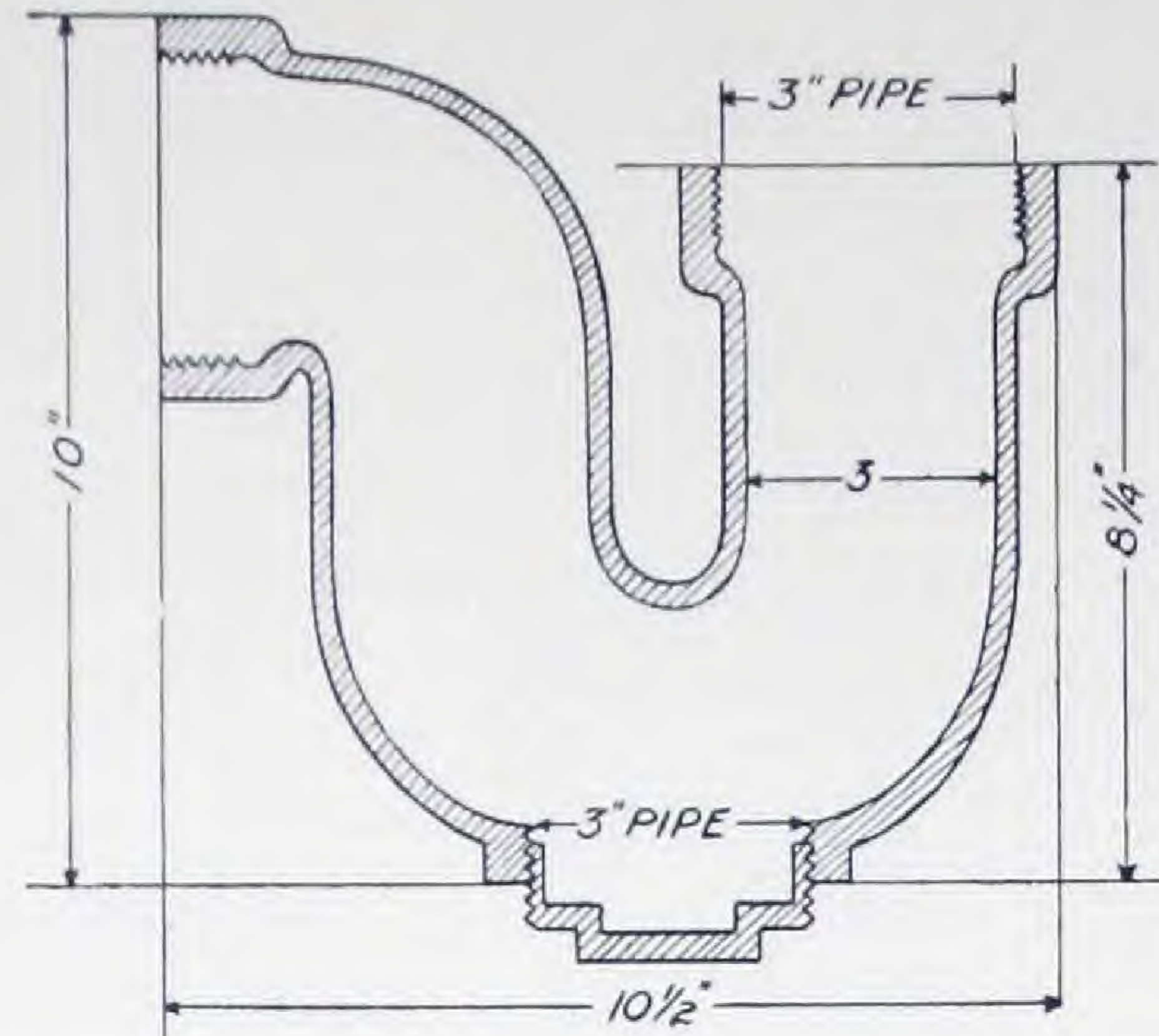

No. 70-A

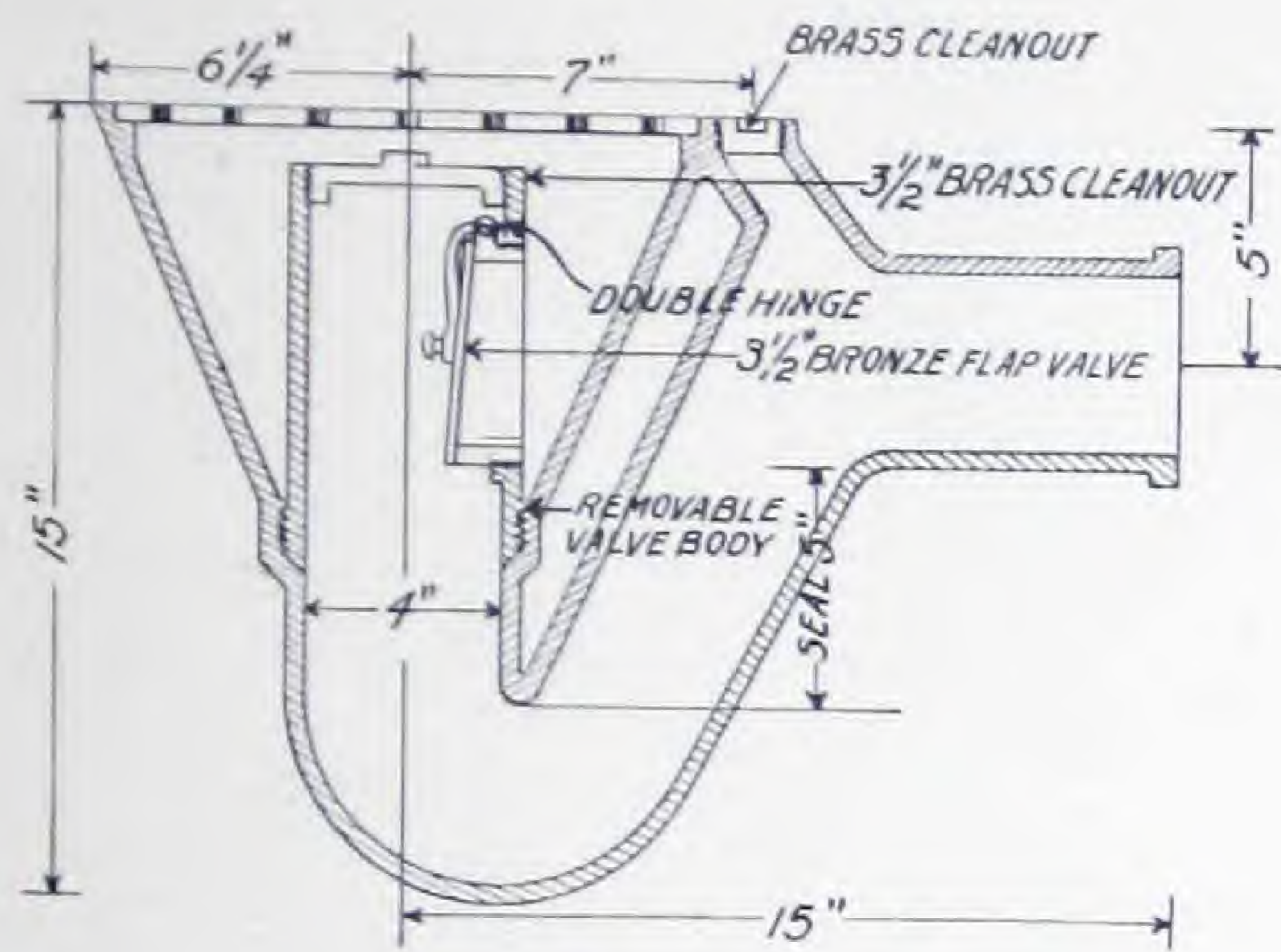

No. 108

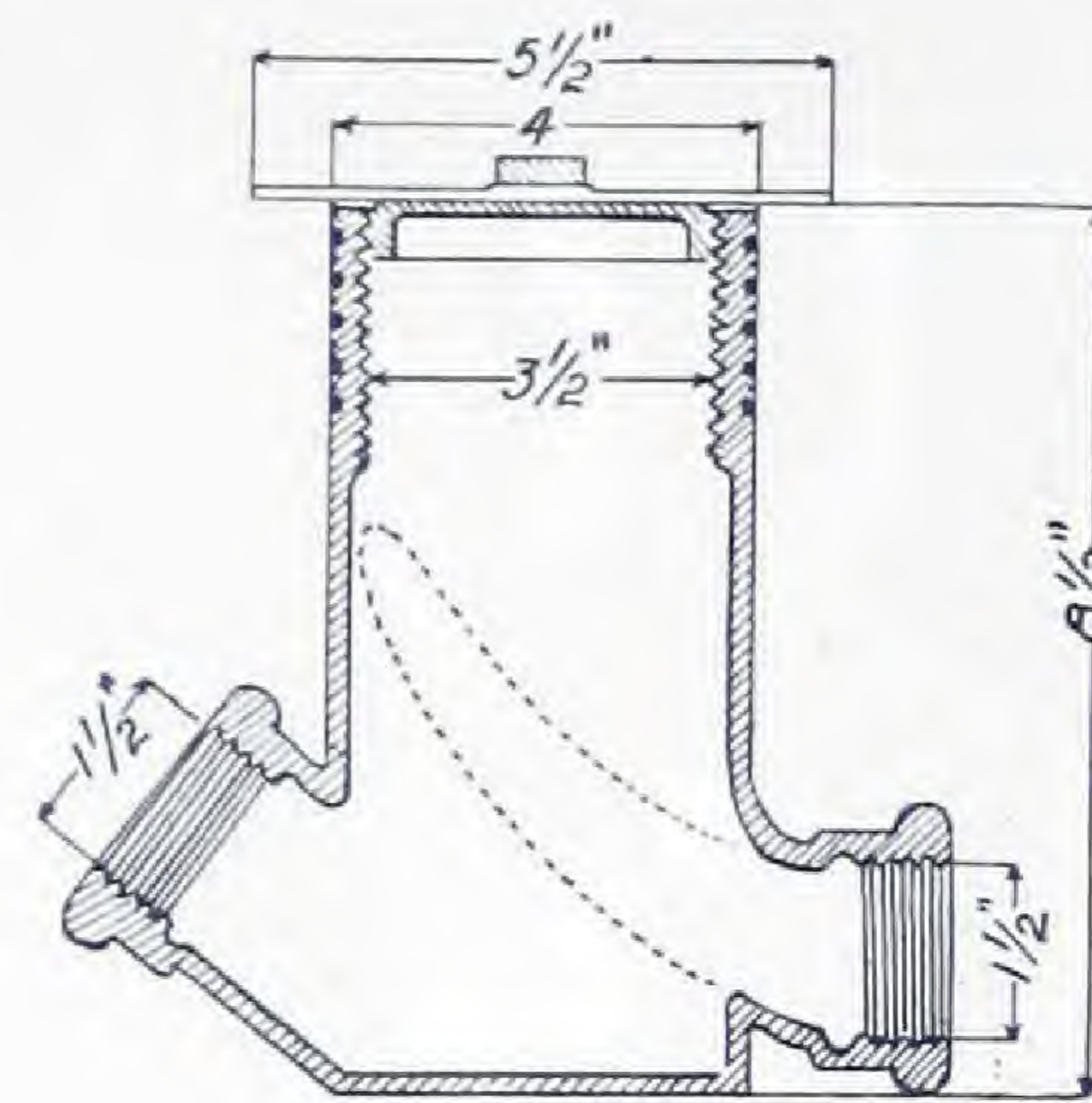

No. 45

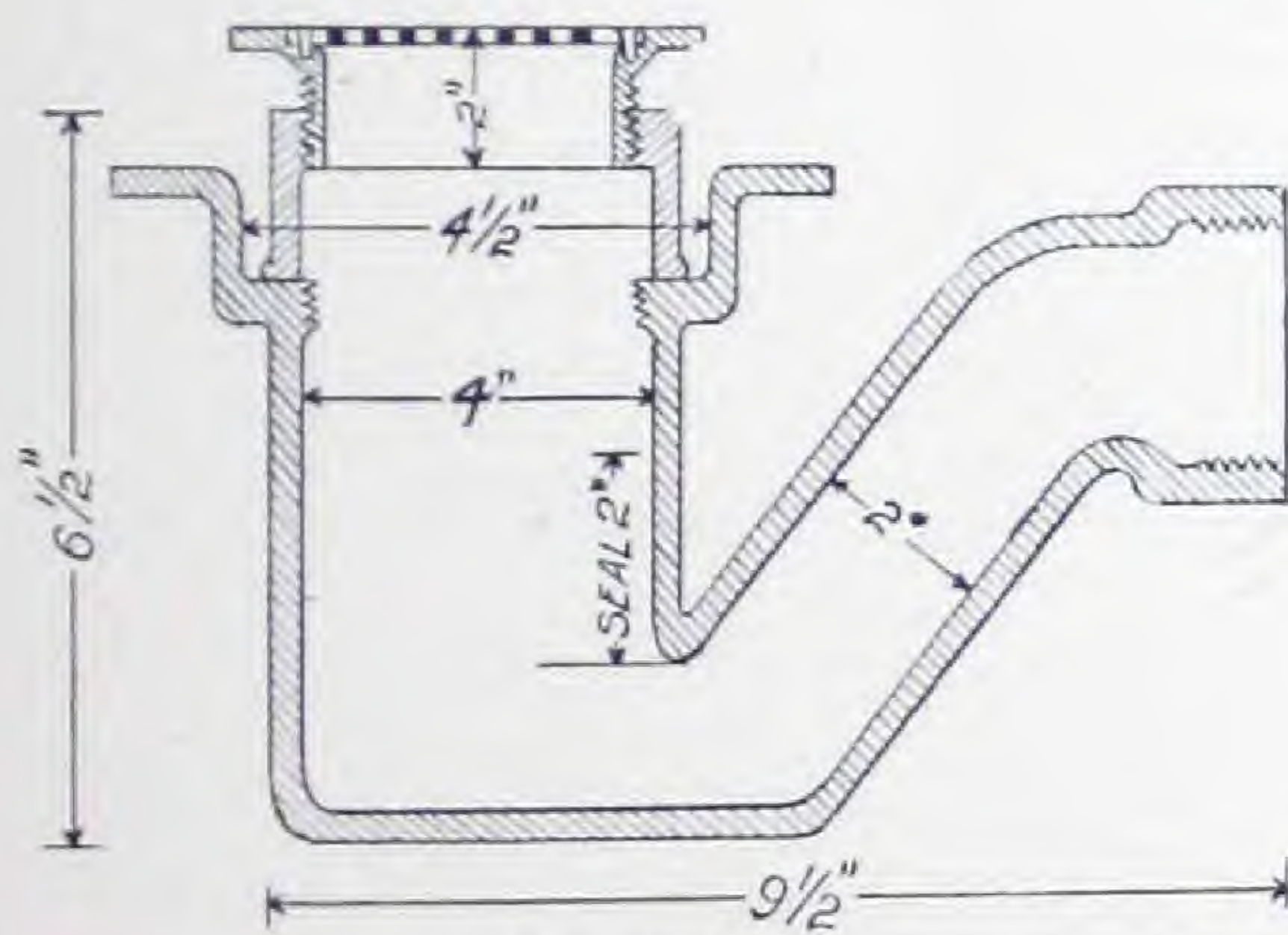

No. 125

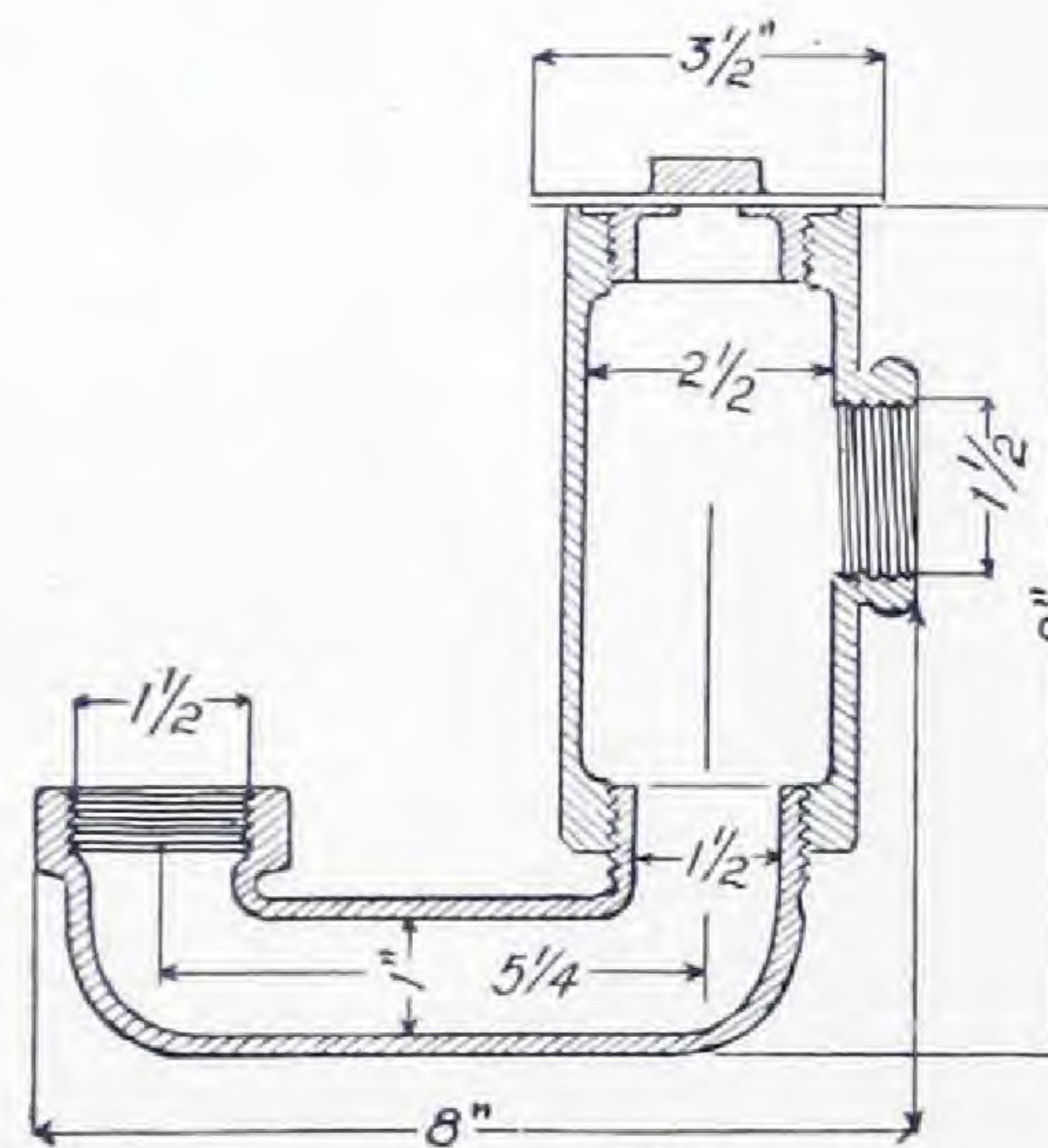

No. 4-B

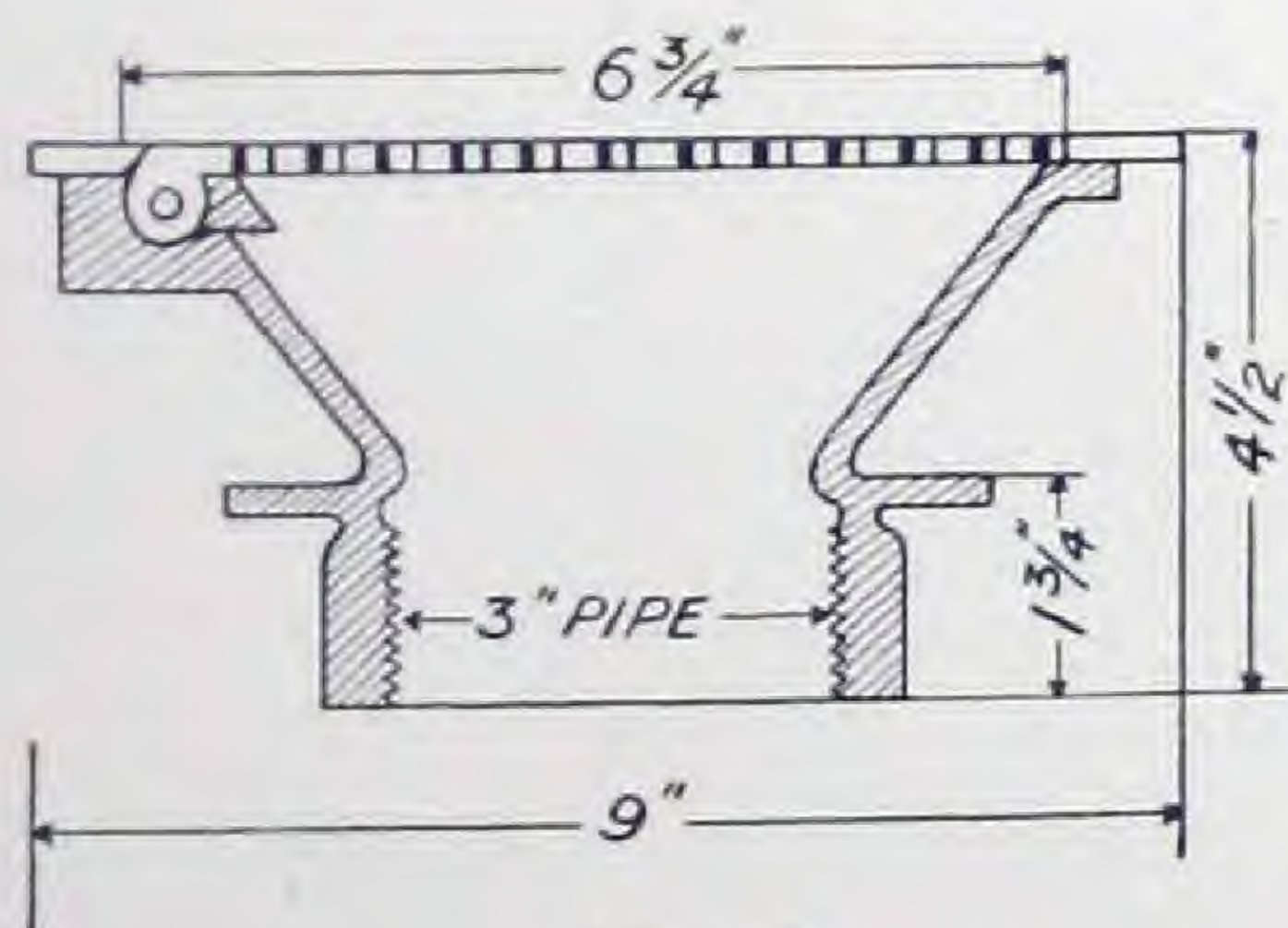

No. 92

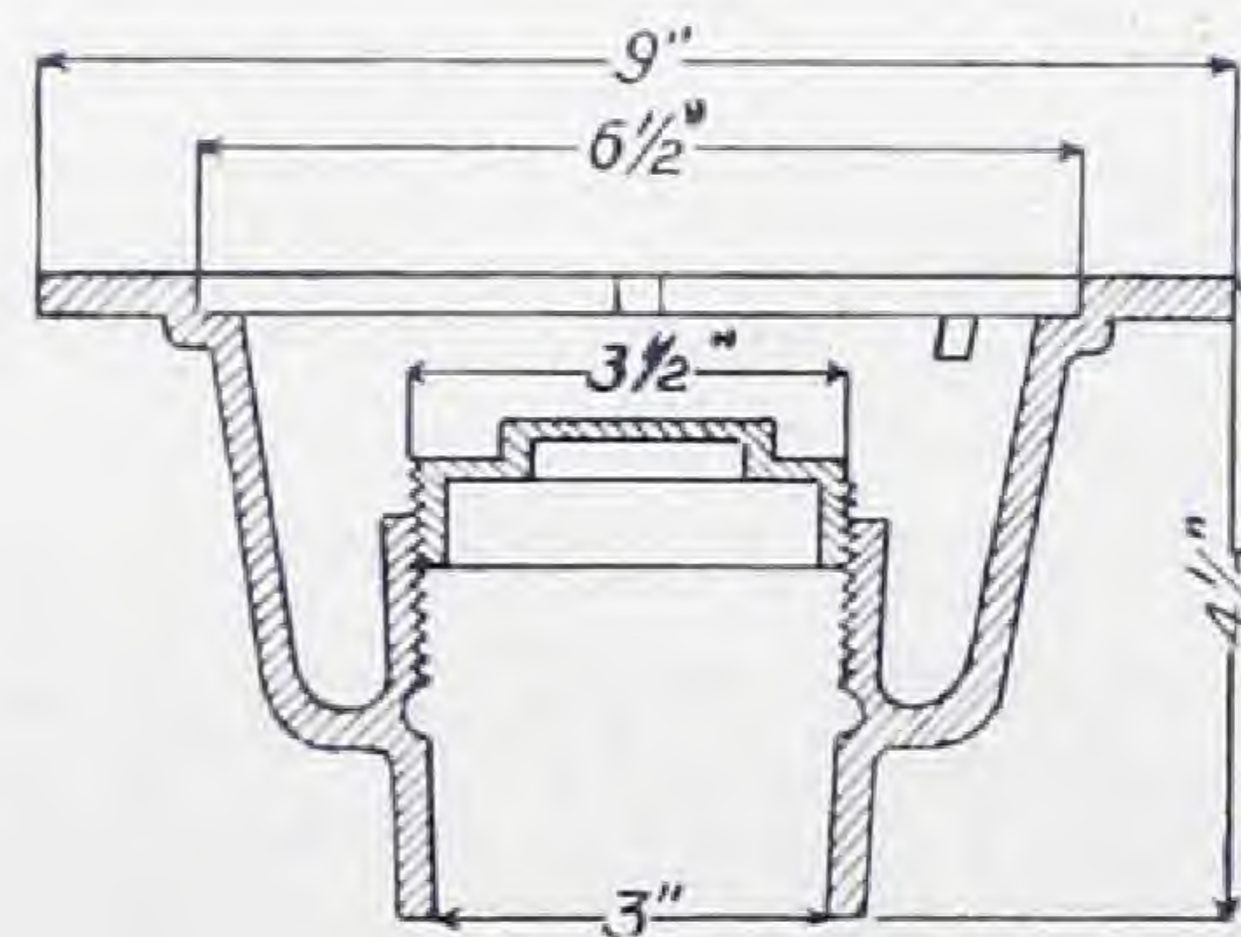

No. 863-B

The City of Detroit

The City of Detroit installs the Greenwood Manufacturing Co.'s iceless water coolers with all permanent drinking fountains in the park system.

Eighteen
summers of
constant
satisfactory
public
service
and never
one cent
for repairs

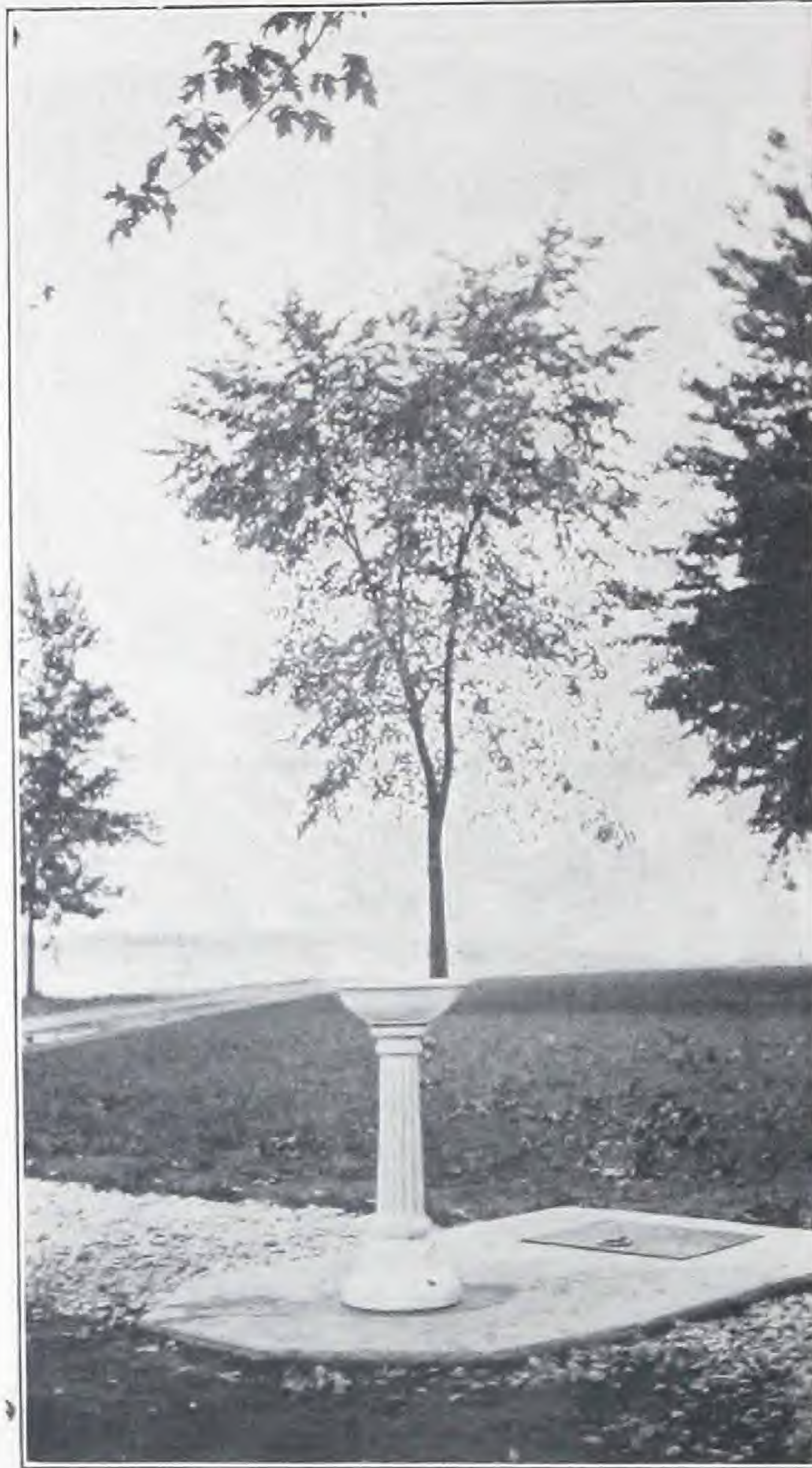

This picture
shows
drinking foun-
tain equipped
with iceless
water cooler.
Belle Isle,
near
bath house.

DEPARTMENT PARKS AND BOULEVARDS CITY OF DETROIT

Greenwood Manufacturing Co.,
Detroit, Mich.

Gentlemen:

The fact, that each year, we have added to the number of coolers installed is probably our best recommendation. We have had absolutely no trouble with any of them and the public seems to be well pleased.

Very truly yours,

WM. T. DUST, Commissioner.

Iceless Water Coolers

Iceless water coolers for ground or first floor installations automatically take care of themselves, requiring no further care or trouble and furnishing cold water at a temperature varying from 50° to 58°—cold enough for the most exacting—having the desirable qualities of ice water and none of its objectionable features or none of its harmful effects.

These coolers have for the past 18 years saved the city of Detroit thousands of dollars annually for ice, together with other hundreds that were previously spent yearly in keeping the old style ice boxes and cooling coils in repair.

Figuring the service, the cost of upkeep and convenience, the installation of the Greenwood Mfg. Co.'s iceless water coolers pays a wonderful interest on the investment.

The average cost of installing the No. 6 std. cooler in the ground ready for water and waste connections varies between \$200.00 and \$250.00, according to location and ground conditions.



A. J. HOOD & COMPANY
INVESTMENT BANKERS
PENOBSCOT BUILDING
DETROIT

Greenwood Manufacturing Company.
5140 Hamilton Ave.,
Detroit, Michigan.

Gentlemen:-

A year or so ago we purchased and installed on our Culb Grounds, four (4) Iceless Water Fountains and I wish you would quote me price on three (3) more.

These fountains have given most excellent satisfaction - the members are delighted with them and express themselves unqualifiedly in this respect.

They furnish a seemingly endless supply of cold water - cold enough for the most exacting - having all the desirable qualities of ice water, and none of its objectionable features or none of its harmful effects.

From the day these fountains were turned on they automatically took care of themselves, requiring no further care or trouble on our part.

Yours very truly,

A. J. HOOD, Chairman,
Greens Committee
Detroit Golf Club

EN*1
MAY THE EIGHTH
NINETEEN EIGHTEEN

Murray W. Sales, *President*

Tracy S. Smith, *Secretary*

Murray W. Sales & Co.

Plumbers' Steam and Engineers' Supplies

74, 76, 78 Jefferson Avenue
Between Cass and Wayne Street

Detroit, Mich. March 21, 1919.

IN REPLYING REFER TO T. S. S.

Greenwood Mfg. Co.,
Detroit, Mich.

Gentlemen:-

We are pleased to advise that we have in use two (2) of your iceless water coolers, both of which have been in service for several years and both of which have proven very satisfactory

In our pipe shop we have for five years supplied all of our men with a sufficient quantity of drinking water without at any time purchasing any ice. We also supplied drinking water for our store through another cooler, and since its installation have purchased no ice. We can highly recommend your cooler to anyone requiring a large supply of properly cooled drinking water.

Yours very truly,

MURRAY W. SALES & COMPANY

T. S. Smith

Construction of piping and pit for single cooler placed in basement of building

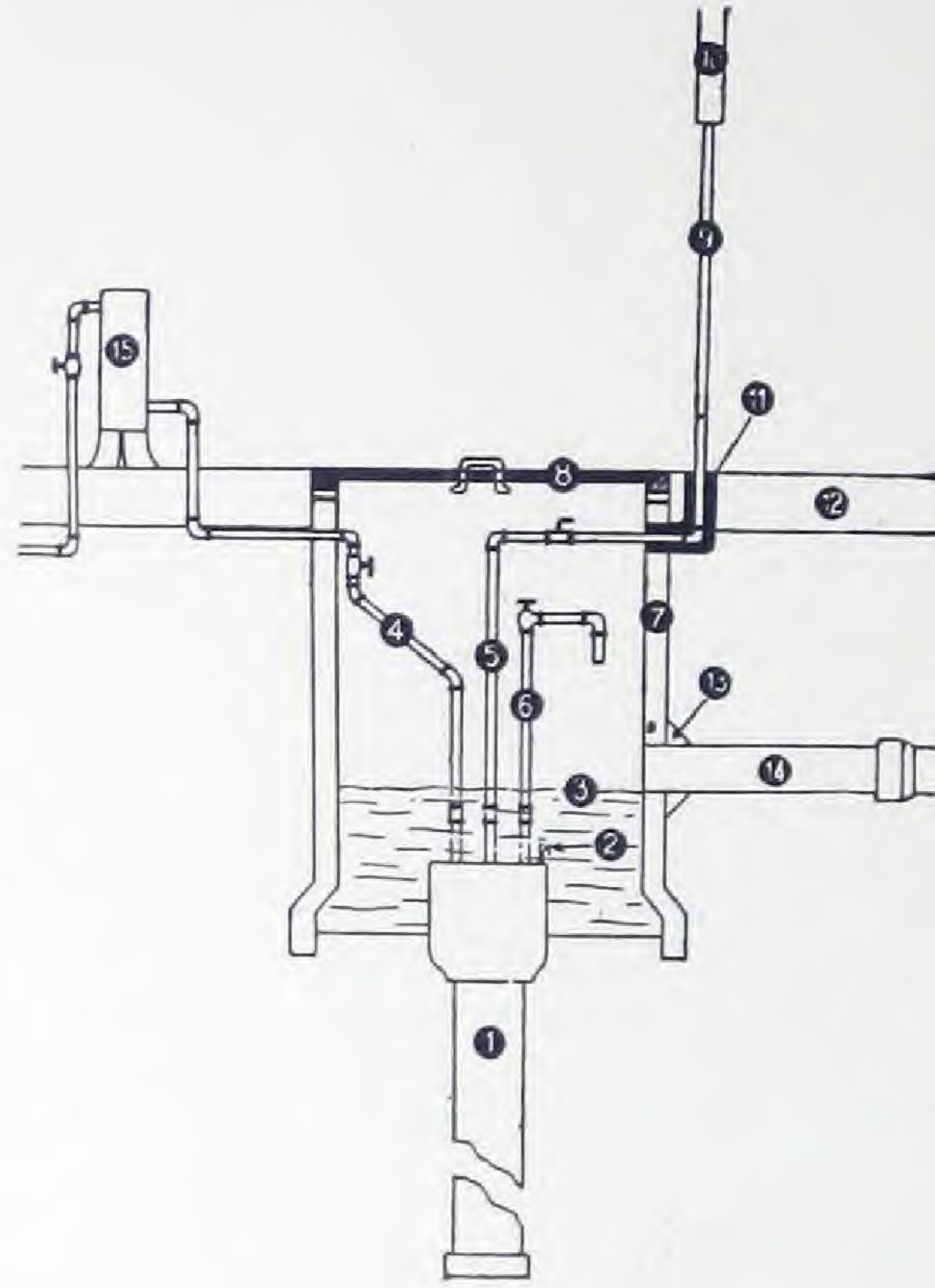

Coolers should be placed directly under fixture and installed when the *cellar is being dug* or before the joists are laid.

1. Iceless Water Cooler.
2. Air relief valve.
3. Water line covering cooler head.
4. $\frac{3}{4}$ -inch supply to cooler.
5. Cold water supply to faucet.
6. Blow-off, removing any sediment from bottom of cooler.
7. Construction of cooler pit, one length of 20-inch glazed crock.
8. Cover and ring.
9. For riser from basement, use $\frac{1}{2}$ -inch galvanized pipe.
10. The riser from the basement floor to faucet should be well insulated.
11. Air space around cold water supply pipe.
12. Cement floor.
13. Overflow from pit.
14. Three-inch crock to conductor line.
15. When filters are used, have water pass through filter before entering cooler.

Drinking Water

Cool and Refreshing as the Coldest Spring
Without Ice

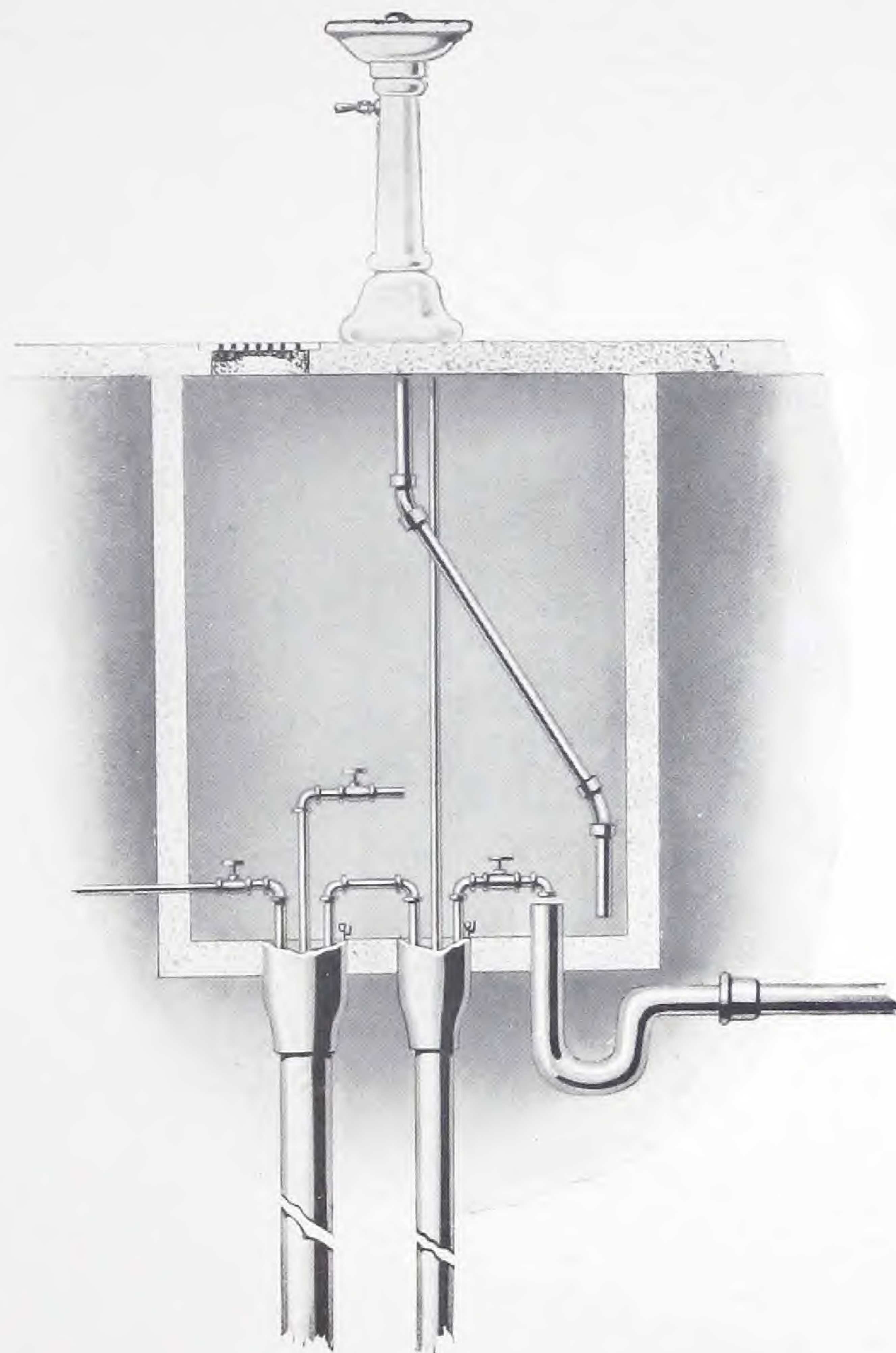

For Streets, Parks, Golf Grounds, Schools, Theaters, Depots, Foundries,
wherever drinking water is required at ground level.

For streets, we recommend that No. 6 Coolers be installed in batteries
of two or three to each fountain, depending upon the traffic conditions.

Iceless Water Coolers

As a permanent investment give unlimited service, abundance of cool drinking water, no added cost for upkeep, eliminates all dirt, always clean and sanitary.

For factory installation we recommend one No. 6 cooler for every 50 to 60 men employed on the ground floor, depending on the kind of employment.

For city parks, playgrounds, schools or railroad depots. a battery of two or three coolers to each fountain, based on an average of cooling 40 gallons per cooler every two hours—in gravelly, wet soil, 40 gallons in 30 minutes. When set in blue clay in a dry hole, waste from the fountain should drain back into pit and seep down around cooler.

In Detroit and vicinity only, quotations, when specified, will include installation of cooler in ground ready for plumbing connections.

Installation of Water Cooler

Any well digger, capable of boring a hole 10 inches in diameter and 32 feet deep, can easily install coolers ready for plumbing connections.

Head room of at least 26 feet is required. Therefore, cooler should be installed before the erection of building.

After cooler is placed, the space around cooler should be filled with gravel or broken stone and waste from fountain drained back into pit and seep down around cooler. For battery installation, coolers should be spaced three feet apart.

For apartment houses furnishing drinking water above the first floor, the iceless water cooler should be used only as a booster and the pit with its waste connections as an ice chest. Less than one-tenth of the normal amount of ice will be required.

NO. 6 COOLER

Capacity	Length	Diameter	Weight
40 Gallons	30 Feet	6½ Inches	740 Lbs.

[BLANK PAGE]



CCA

MEMBERS
THE NATIONAL
TRADE EXTENSION BUREAU
OF THE
PLUMBING AND HEATING INDUSTRY
DEPT. OF COMMERCE REGISTERED