

CONSTRAINT DESIGN SOLVER (CDS)

PRODUCT OVERVIEW

Constraint Design Solver (CDS) is a set of C++ software libraries that enable the easy integration of user-defined 2D profiles and 2D/3D assemblies into a wide-range of industry design applications. The CDS libraries are based on Dassault Systèmes' V5 and V6 technology and incorporate the same robust and industry-proven constraint solver that drives sketching and assembly design in CATIA.

CDS functionality spans the breadth of 2D and 3D design applications with standard geometry objects and constraints as well as multiple solver modes and options. In addition, CDS incorporates easy-to-implement programming interfaces, debugging features, and enables quick integration with geometric modeling kernels such as CGM and 3D ACIS® Modeler.

Such functionality and features combined with support services from Spatial during development phases ensure implementation success. The overall result is faster time-to-market for CDS-enabled applications with fewer resources and lower maintenance costs.

ENABLES FAST DESIGN ITERATIONS

CDS enables real-time manipulation of geometric objects with direct and interactive creation and modification of dimensions and constraints. Such a variational approach to design yields large productivity advantages because it allows designers to rapidly iterate through different configurations and quickly achieve an optimal design under specified constraints

KEY FEATURES

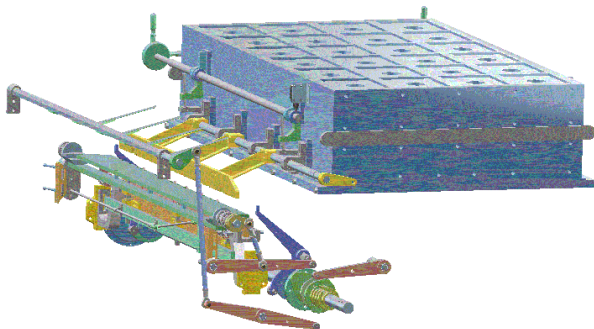

Solid Technology Foundation: A core constituent of Dassault Systèmes' V5 and V6 technology in demanding markets such as aerospace, automotive and industrial machinery.

Comprehensive Functionality: A complete suite of geometry objects coupled with extensive dimensional and logical constraints enable the definition and modification of 2D profiles and relative positioning of 3D assemblies.

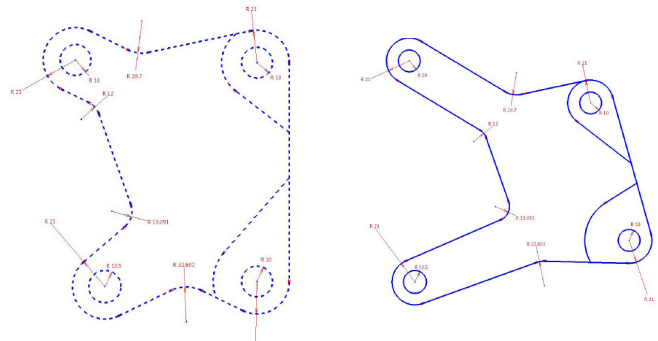

High-Performance Solver: A robust, quick, and flexible thread-safe solver solves or analyzes under- and over-constrained problems with multiple solver options and diagnostic tools.

Easy-to-Implement Component Interfaces: Object-oriented design provides clear interfaces for implementing self-contained C++ APIs.

Quality Assurance Tools: Replay and scripting features as well as a graphical display environment ensure debugging ease and fast implementations.

Getting-Started Framework: Spatial provides essential functionality within a 'getting started' application infrastructure for fast implementation.

Enhanced Productivity: CDS drives productivity and decreases time-to-market by enabling developers to freely concentrate on their core competencies without considering the mathematical intricacies of geometric constraint solvers.

COMPREHENSIVE FUNCTIONALITY

CDS provides a complete suite of built-in geometry objects with both dimensional and logical constraints.

- **Geometry Objects:** points, lines, NURBS, curves and surfaces; circles, ellipses, parabolas and hyperbolas; cylinders, cones, spheres, and tori
- **Dimensional Constraints:** coordinates, distances, lengths, radii, angles, curvature
- **Logical Constraints:** coincidence, tangency, parallelism, perpendicularity, symmetries
- **Advanced Constraints:** user-defined expressions and conditions, rigid sets, patterns, joints, local control of chirality (design-intent)

HIGH-PERFORMANCE SOLVER

At the core of CDS lies a non-linear simultaneous equation solver, whose speed, robustness, and flexibility underpin its functionality with full support for over- and under-constrained configurations.

Solver Modes: update, interactive design via move-under-constraints ('dragging'), and simulation of prescribed design iterations such as direct kinematics; analyses of degrees-of-freedom (DOF) and degrees-of-symmetry (DOS), auto-constraining, diagnostics

Solver Options: global maintenance of chirality; control of movements within and outside of rigid sets

EASY IMPLEMENTATION

Clear interfaces, useful debugging features and a ready-to-use 'getting started' infrastructure enable developers to quickly implement CDS functionality into their application and enhance development productivity.

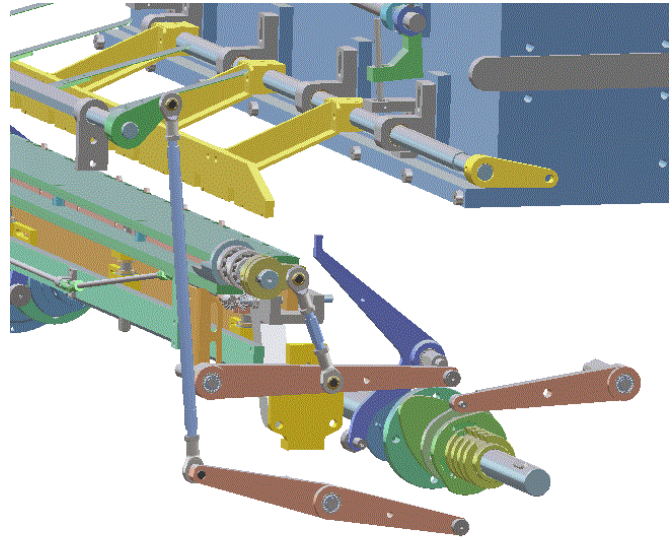

Clear Interfaces: C++ APIs with straightforward layout and full documentation preserve independence between CDS and its overlying application and any geometric modeler

Debugging Features: scripting and replay capabilities enable quick identification of application bugs and errors

Ready-to-Use Infrastructure: essential CDS functionality is offered in a pre-programmed 'getting started' application infrastructure to aid implementation

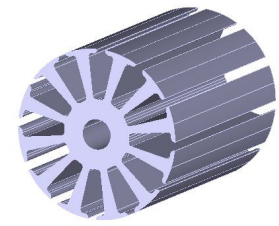
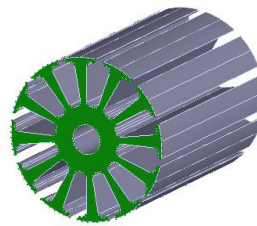
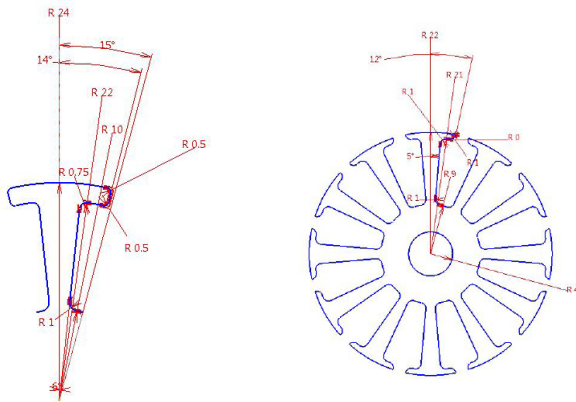

Our 3DEXPERIENCE® platform powers our brand applications, serving 12 industries, and provides a rich portfolio of industry solution experiences.

Dassault Systèmes, the 3DEXPERIENCE® Company, provides business and people with virtual universes to imagine sustainable innovations. Its world-leading solutions transform the way products are designed, produced, and supported. Dassault Systèmes' collaborative solutions foster social innovation, expanding possibilities for the virtual world to improve the real world. The group brings value to over 190,000 customers of all sizes in all industries in more than 140 countries. For more information, visit www.spatial.com.



3DEXPERIENCE®