



4-WIRE DUCT SMOKE DETECTOR

DESCRIPTION

The System Sensor Innovair™ (Fike P/N 67-1048) is a 4-wire ionization air duct smoke detector capable of sensing smoke in air velocities from 500 to 4,000 feet per minute (2.54 to 20.32 m/sec). This detector was developed to constantly monitor the air within a duct and to detect the presence of smoke.

The two available for C relay contacts provide reliable performance for the management of fans, blowers and air conditioning systems. These HVAC devices can be configured to prevent the spread of toxic smoke and fire gasses through a protected area.

The Innovair family is designed for simplified installation and easy maintenance. The modular construction allows for easy cleaning and uncomplicated field replacement of the UL recognized power and sensor boards. The patented cover missing feature insures the cover is securely tightened following routine cleaning and maintenance. The patented interconnectability feature allows multiple Innovairs to communicate with each other. In the event smoke is detected, the Innovair will signal the remaining interconnected detectors to initiate their relays for smoke control.

Warning: Duct smoke detectors have specific limitations.

Duct Smoke Detectors are:

- NOT a substitute for an open area smoke detector,
- NOT a substitute for early warning detection, and
- NOT a replacement for a building's regular fire detection system

Refer to NFPA 72 and 90A for additional information about the proper application of duct smoke detectors.

FEATURES

- Air velocity rating from 500 to 4000 feet per minute (2.54 to 20.32 m/sec.)
- Patented Interconnectability for multi-fan shutdown (up to ten air handlers)
- Patented telescopic sampling tube
- Patented cover tamper trouble signal
- 24 VAC/DC or 120/240 VAC operation
- High-Low voltage barrier
- Equipped with two DPDT Form C relay contacts
- Built-in reset button
- Outside mounting tabs
- Easy and quick mounting to round or rectangular ducts from 1'-12' (0.3-3.7 meters) wide
- Easy to clean
- UL recognized field-replaceable power and sensor boards
- Remote test station option
- Remote sounder option
- Transparent cover for convenient visual inspection
- UL 268A listed
- 3-year warranty
- Photoelectric model available

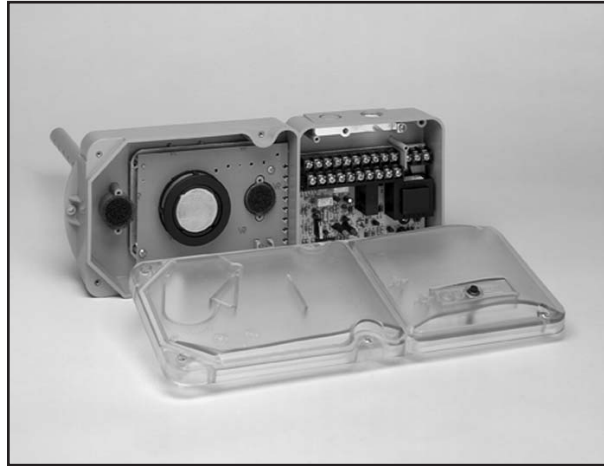

APPROVALS

- UL Listed
- FM Approved

ARCHITECTURAL/ENGINEERING SPECIFICATIONS

The air duct smoke detector shall be a System Sensor Model (Fike P/N 67-1048) Series Duct Smoke Detector. The detector housing shall be UL listed per UL 268A specifically for use in the air handling systems. The detector shall operate at air velocities of 500 feet per minute to 4000 feet per minute (2.54 to 20.32 meters/second). The unite shall be capable of controlling up to ten (10) air handling systems when interconnected with other detectors. The detector shall be capable of providing a trouble signal in the even that the front cover is removed. It shall be capable of local testing via magnetic switch or remote testing using 02-11489 Multi-Signaling Accessory or 02-4998 Remote Test Station. The unit shall be reset by local reset button or remote test station. The duct smoke detector housing shall incorporate an airtight smoke chamber in compliance with UL 268A, Standard for Smoke Detectors for Duct Applications. The housing shall be capable of mounting to either rectangular or round ducts without adapter brackets. An internal filter system shall be included to reduce dust and residue effects on detector and housing, thereby reducing maintenance and servicing. Sampling tubes shall either be telescoping or be easily installed by passing through the duct housing after the housing is mounted to the duct. The unit shall provide a spacial separation of no less than 1/4" (6.4 mm) and/or a physical barrier between the high and low voltage terminals. The enclosure shall meet all applicable NEC and NFPA standards regarding electrical junction boxes. Terminal connections shall be of the strip and clamp method suitable for 12-18 AWG wiring.

WIRING GUIDE

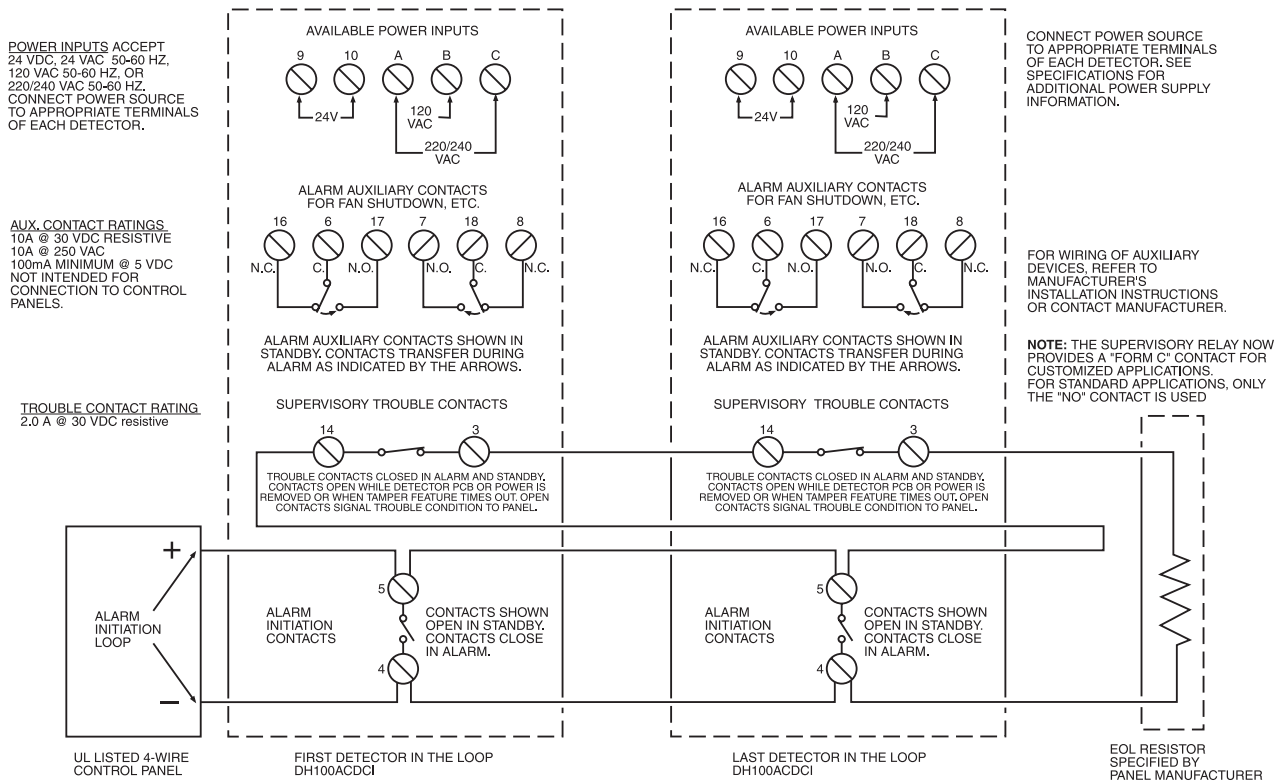

SPECIFICATIONS

Size: 14-3/8" (37 cm.) Length, 5-1/2" (14 cm.) Width, 2-3/4" (7 cm.) Depth
 Shipping Weight: 3/3-4 lbs. (1.7 kg.)
 Operating Temperature Range: 32° to 120°F (0° to 49°C)
 Operating Humidity Range: 10% to 93% relative humidity non-condensing
 Air Duct Velocity: 500 to 4000 ft./min (2.54 to 20.32 m/sec.)

ELECTRICAL RATINGS - P/N 67-1048 (INCLUDES DETECTOR)

Power Supply Voltage:	20-29 VDC	24 VAC 50-60 Hz	120 VAC 50-60 Hz	220/240 VAC 50-60 Hz
Input Capacitance:	270 μ F max.	270 μ F max.	n/a	n/a
Reset Voltage:	3.0 VDC min.	2.0 VAC min.	10 VAC min.	20 VAC min.
Reset Time (with RTS451):	.03 to 0.3 sec.	.03 to 0.3 sec.	.03 to 0.3 sec.	.03 to 0.3 sec.
Reset Time (by power down):	0.6 sec. max.	0.6 sec. max.	0.6 sec. max.	0.6 sec. max.
Power Up Time:	34 sec. max	34 sec. max	34 sec. max	34 sec. max
Alarm Response Time:	2 to 17 sec.	2 to 17 sec.	2 to 17 sec.	2 to 17 sec.
Sensitivity Test:	See detector label	See detector label	See detector label	See detector label
Current Requirements (Using No Accessories)				
Max. Standby Current	15 mA	35 mA RMS	25 mA RMS*	15 mA RMS*
Max. Alarm Current	70 mA	125 mA RMS	25 mA RMS*	25 mA RMS*
Contact Ratings				
Alarm Initiation Contacts (SPST)	2.0 @ 30 VAC/DC (0.6 power factor)			
Alarm Auxiliary contacts (DPDT)	10A @ 30 VDC 10A @ 250 VAC Note: Alarm auxiliary contacts must switch 100 mA minimum at 5VDC. Alarm auxiliary contacts shall not be connected to initiating circuits of control panels. Use the alarm initiation contact for this purpose			
Trouble Contacts (SPDT)	2.0A @ 30 VDC (resistive)			

Accessory Current Loads at 24 VDC				
Fike P/N	Device	Standby	Trouble	Alarm
02-11490	APA451	12.5mA Max	n/a	30mA Max.
20-130-134	PA400	0mA	n/a	15mA Max.
02-3868	RA400Z	0mA	n/a	10mA Max.
02-3869/ 02-11489	RTS451/ RTS451KEY	12mA*	n/a	7.5mA Max.
02-11489	SSK451	5mA Max.	0mA max.	30mA Max.

Note: When a unit is powered at the 120VAC or 220/240VAC input, any combination of accessories may be used such that the given accessory loads are: 50 mA or less in the standby state; 110 mA or less in the alarm state.

Important Interconnect Notes:

- When using the interconnect feature, all interconnected units must be powered with the same, independent supply.
- Polarity must be maintained throughout the interconnect wiring. Connect terminal 12 on unit 1 to terminal 12 on unit 2 and so on. Similarly, connect terminal 1 on unit 1 to terminal 1 on unit 2 and so on.

Wiring diagram for 67-1048 to 02-11490

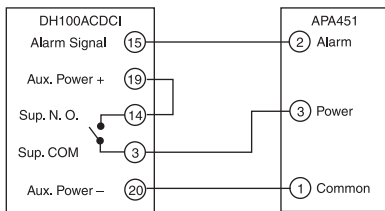

NOTE: Wiring diagram shown is for DH100ACDCI 4-wire duct smoke detector system equipped without a control panel.

NOTE: A trouble condition is indicated when the green LED is not illuminated.

Wiring Diagram for 67-1048 to 02-11489 and interconnect feature

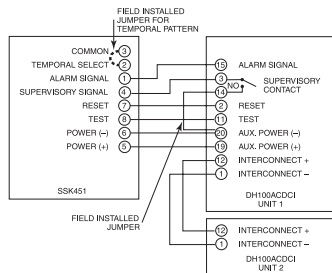

Wiring diagram for the 02-3869/02-4998 and interconnect feature

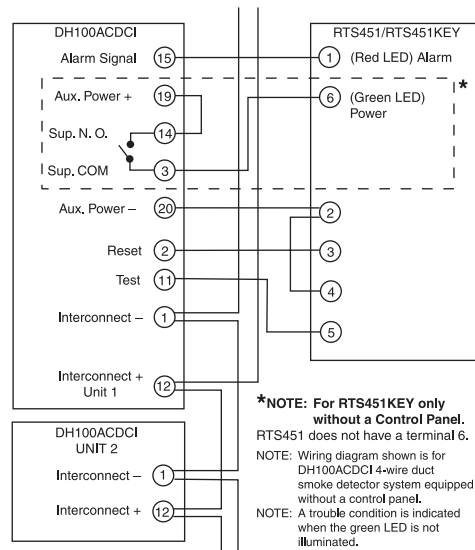

***NOTE: For RTS451KEY only without a Control Panel.** RTS451 does not have a terminal 6.

NOTE: Wiring diagram shown is for DH100ACDCI 4-wire duct smoke detector system equipped without a control panel.

NOTE: A trouble condition is indicated when the green LED is not illuminated.

Coil Note: Please note that the magnetic coil supplied with the 02-3869/02-4998 is not required when these accessories are used with the 63-1050 detector. The functionality of the magnetic coil has been designed into the circuitry of the Innovair duct smoke detectors.

ORDERING INFORMATION

Fike P/N	Mfg. P/N	Description
67-1048	DH100ACDCI	4-wire ionization duct detector
67-1038	A5052	Replacement ionization detector board
02-4673	A5064	Replacement 4-wire power board
023721	ST-1.5	Metal sampling tube duct widths 1'-2' (0.3-0.6 m)
02-3722	ST-3	Metal sampling tube duct widths 2'-4' (0.6-1.2 m)
02-3723	ST-5	Metal sampling tube duct widths 4'-8' (1.2-2.4 m)
02-3724	ST-10	Metal sampling tube duct widths 8'-12' (2.4-3.7 m)
02-4675	T80-71-00	Replacement telescoping sampling tube
02-4677	P48-55-00	Replacement end cap for T80-71-00
02-11489	SSK451	Multi-Signaling accessory
02-4998	RTS451KEY	Remote test station with key lock
02-3869	RTS451	Remote test station
02-11490	APA451	Remote annunciator with piezo alarm
02-3727	MOD400R	Sensitivity test module
02-3868	RA400Z	Remote annunciator alarm LED
02-4676	F36-09-11	Replacement air filters (two per package)
02-4980	M02-04-00	Test magnet
02-4677	P48-21-00	End cap for metal sampling tubes
02-9976	S08-39-01	Photo replacement screen
20-130-134	PA400W	Mini-Alert sounder
20-1091	PS24LOW	Mini-Alert add-on strobe
02-11491	PS12/24LENSW	Wall-mount "SMOKE" lens

ACCESSORIES

System Sensor provides system flexibility with a variety of accessories, including two remote test stations, and several different means of visible and audible system annunciation. As with our duct detectors, all duct smoke detector accessories are UL listed.

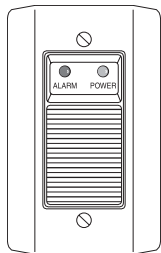

P/N 02-11490
Piezo Annunciator
(UL S4011)

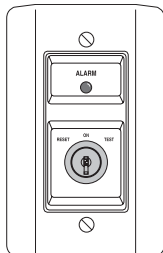

P/N 02-4998
Remote Test Station
with Key (UL S2522)

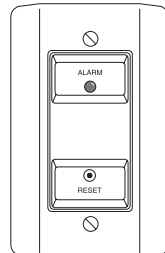

P/N 02-3869
Remote Test Station
(UL S2522)

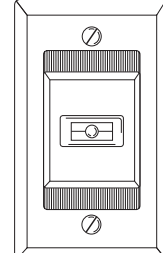

P/N 02-3868
Remote Annunciator
(UL S2522)

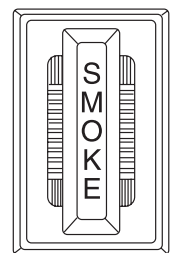

P/N 20-130-134
Mini-Alert Sounder
(UL S3593)

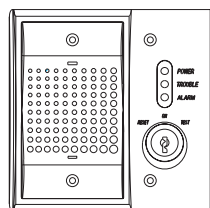

P/N 02-11489
Multi-Signaling Accessory
(UL 268A)

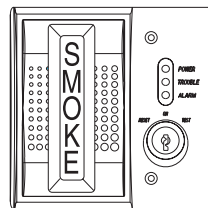

P/N 02-11489
Multi-Signaling Accessory
(UL 268) shown with
P/N 20-1091 add-on strobe
(P/N 02-11491 smoke lens
option available)

